

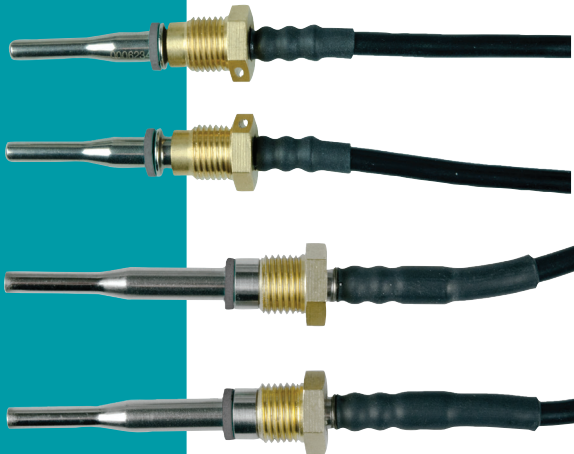

TemperatureSensor SP
(DS 27.5/DS 38)





TemperatureSensor SP (DS 27.5/DS 38)



> 60 °C

At a media temperature higher than 60 °C, the temperature sensor should be shielded from unintended contact.



16/25 bar

When working on the temperature sensor in the installation, there is a risk of outflow of (hot) water under pressure.



Contents

	In general	04
	Information	05
	Mounting of temperature sensors	06
	Mounting of installation seals	11



In general



www.kamstrup.com/en-en/product-centre/temperaturesensor-sp

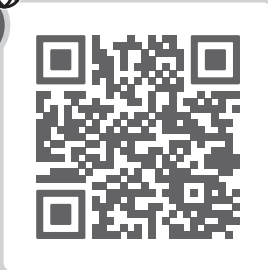

<https://www.kamstrup.com/>



1/1



MID ✓

EN 1434 ✓

θ: 0 °C...150 °C

Δθ: 3K...150 K ✓

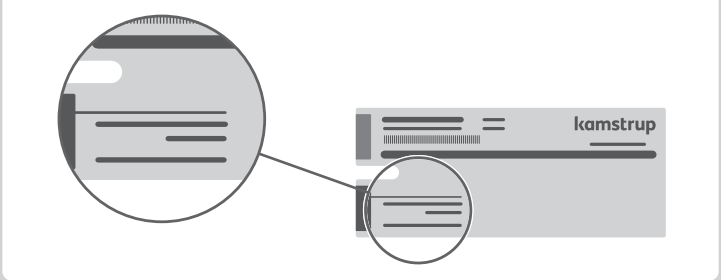

The temperature sensor's approval and temperature area

The temperature sensor's approval and temperature area for heat measurements [E1]. These data can also be found on the temperature sensor label.

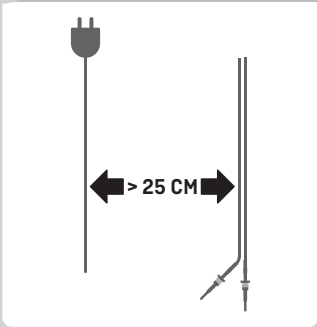

M1 ✓

M2 ✓



0 °C...55 °C ✓



IP 65 ✓

The temperature sensor's environmental and mechanical classes

The temperature sensors must be mounted indoors in the temperature range of 0 °C...55 °C. The temperature sensors's signal cables should be drawn at least 25 cm away from other installations.



Mounting of temperature sensors



1/5



PN16, PN25



max 2 m/s @ 25 bar

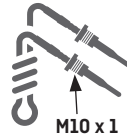

Approved pressure class of the temperature sensor

Temperature sensors are approved for PN16 and PN25. Thread: M10 x 1; $v_{max} = 2$ m/s @ 25 bar

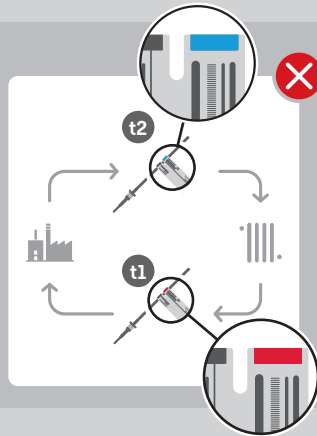
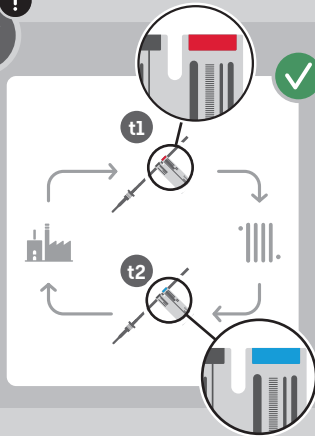

Mounting the temperature sensor

t1 is always mounted in inlet, whereas t2 is always mounted in outlet. t1 and t2 appear from the temperature sensor label.



Mounting of temperature sensors

2/5

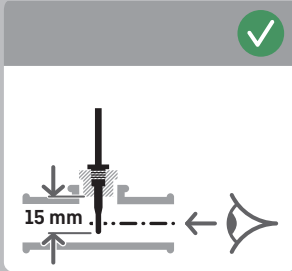

$v < 2 \text{ m/s @ 25 bar}$

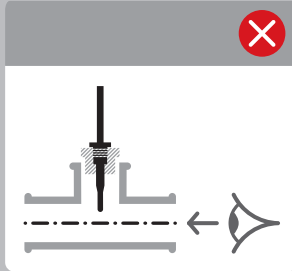
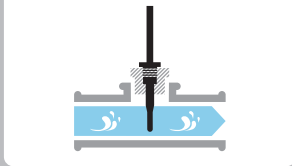

$v > 2 \text{ m/s @ 25 bar}$

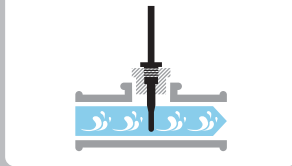

Mounting/immersion depth of the temperature sensor

The sensor must as a minimum be immersed 15 mm in water and cross the centre of the pipe to ensure correct temperature measurement. The max flow velocity must not exceed 2 m/s @ 25 bar.

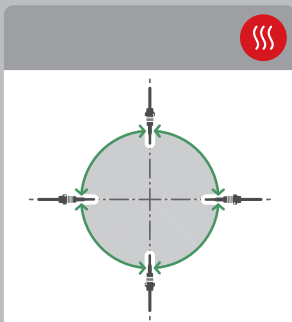

Temperature sensor's orientation

Be aware of the sensor's orientation around the pipe axis.
Heat: All orientations are acceptable.









Mounting of temperature sensors



3/5



					
q _p	DN	G	DS 27,5	DS 38	DS 38 + 11 mm
0.6-1.5	15	G¾B	X	-	X
0.6-1.5	20	G1B	X	-	X
3.5-6	25	G5/4B	X	-	X
10	32	G2B	-	X	-
15	40	-	-	X	-

Temperature sensor, flow sensor and ball valve compatibility

The size of the flow sensor/ ball valve determines which temperature sensors you can use and how they are mounted.

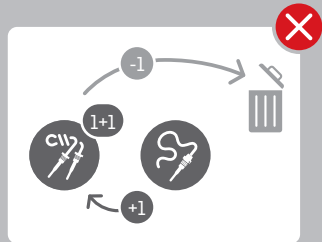
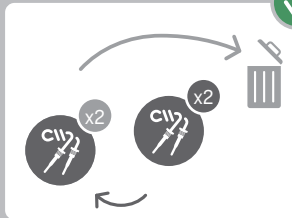

Replacing two temperature sensors

When replacing temperature sensors, both sensors must be replaced by a new paired set. It is not allowed to replace only one temperature sensor.



Mounting of temperature sensors



4/5

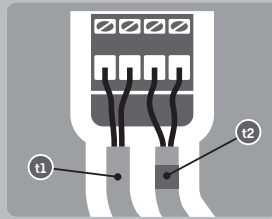

Connecting cables in calculator

The 2-wire cable for t2 is indicated with a ring at the cable end.

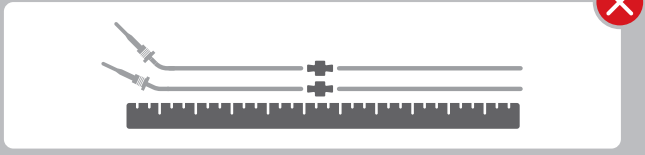
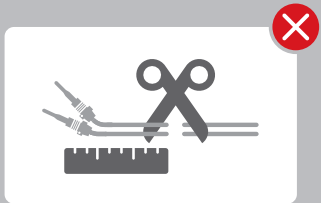
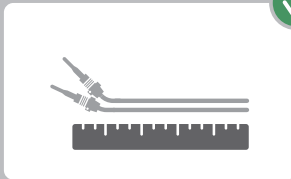

Shortening or extending of temperature sensor cables

It is not allowed to shorten or extend the cables of the temperature sensor.



Mounting of temperature sensors



5/5

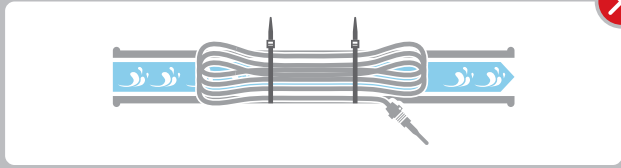
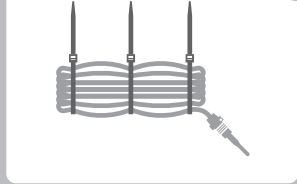
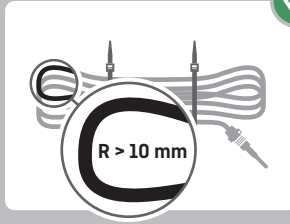

Cable insulation of the temperature sensor

If the temperature sensor cables are bent in connection with the mounting, a bending radius of at least 10 mm must be ensured. Temperature sensor cables must not be mounted on the hot or cold pipe.



Mounting of installation seals



1/1

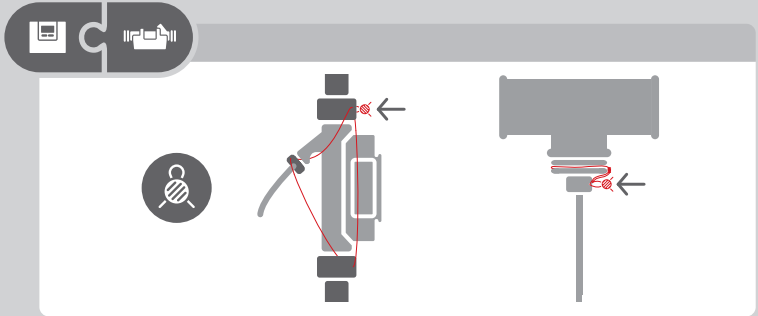

Mounting of installation seals

To protect against fraud on the meter installation, installation seals must be mounted. The sealing of the installation can, for example, be done by means of wire and seal, sealing label or a combination of these.

