

Kamstrup's handbook on

Temperature sensors for heat and cooling meters



Temperature sensors

Contents

1	Introduction	5
2	Resistance temperature sensors	6
2.1	The correlation between temperature and electrical resistance	6
2.2	Measuring principles and design of temperature sensors	7
2.2.1	2-wire temperature measurement	7
2.2.2	4-wire temperature measurement	8
2.3	Applied types of resistance elements	9
2.4	Resistance tables	10
3	Temperature sensors for heat and cooling meters	11
3.1	2-wire temperature sensors	11
3.1.1	Direct short temperature sensor	12
3.1.2	Pocket sensors	12
3.2	4-wire temperature sensors	13
3.2.1	∅5,8 mm pocket sensor with connection head	14
3.2.2	∅6,0 mm pocket sensor with connection head	15
4	Terminology for temperature sensors used in energy measurement.....	16
4.1	Response time	16
4.2	Heat conduction error	18
4.3	Qualifying immersion depth	19
5	Regulatory requirements for marketed temperature sensors.....	20
5.1	Type approval	20
5.2	Measurement and verification	22
5.3	Requirements for temperature sensor set	23
5.4	Requirements for temperature sensor cables	24
5.5	Labelling of temperature sensors and pockets	25
6	Installation of temperature sensors	27
6.1	Symmetric installation	27
6.2	Installation length	28
6.3	Installation in large pipes	30
6.3.1	Connection example: 4 temperature sensors with 2-wire	31
6.3.2	Connection example: 4 temperature sensors with 2-wire combined with 4-wire	32
6.3.3	Connection example: 4 temperature sensors with 4-wire	33
6.4	Other installation conditions affecting the temperature measurement	33
6.5	Installations with high flow rates and/or a high combination of pressure and temperature	34
6.6	Sealing of two temperature sensors	34

Temperature sensors

7	Accessories for the installation of temperature sensors	37
7.1	Ball valve.....	37
7.2	Installation in old ball valves.....	37
7.3	Nipple.....	38
7.4	Tee with M10x1 thread.....	38
7.5	11 mm adapter for DS 38 mm temperature sensor.....	39
8	Application of temperature sensors for cooling meters	40
8.1	Correct measurement of the inlet temperature.....	40
8.2	Condensation problems.....	41
9	References	43

1 Introduction

For a heat or cooling meter to calculate the consumed amount of energy, it is necessary to measure the temperature difference between the inlet pipe and the outlet pipe. The temperature difference is measured by means of two temperature sensors, and temperature sensors are thus an essential part of a heat or cooling meter. Therefore, a number of requirements are laid down for heat and cooling meters, including type approval, test in connection with verification and correct installation.

The purpose of this handbook is to provide an introduction to the most important topics within temperature sensors for heat and cooling meters. After an introduction to resistance temperature sensors, the handbook touches on topics such as the applied types of temperature sensors, regulatory requirements for temperature sensors, installation of temperature sensors and the special conditions that apply to temperature sensors for cooling meters.

In connection with standardisation work within the framework of EN1434 [1], the term “thermal energy meters” is used increasingly as an overall term for both heat and cooling meters. As the terms “heat meters” and “cooling meters” are still by far the most commonly used terms, the term “heat and cooling meters” is used in this handbook as the overall term instead of “thermal energy meters”.

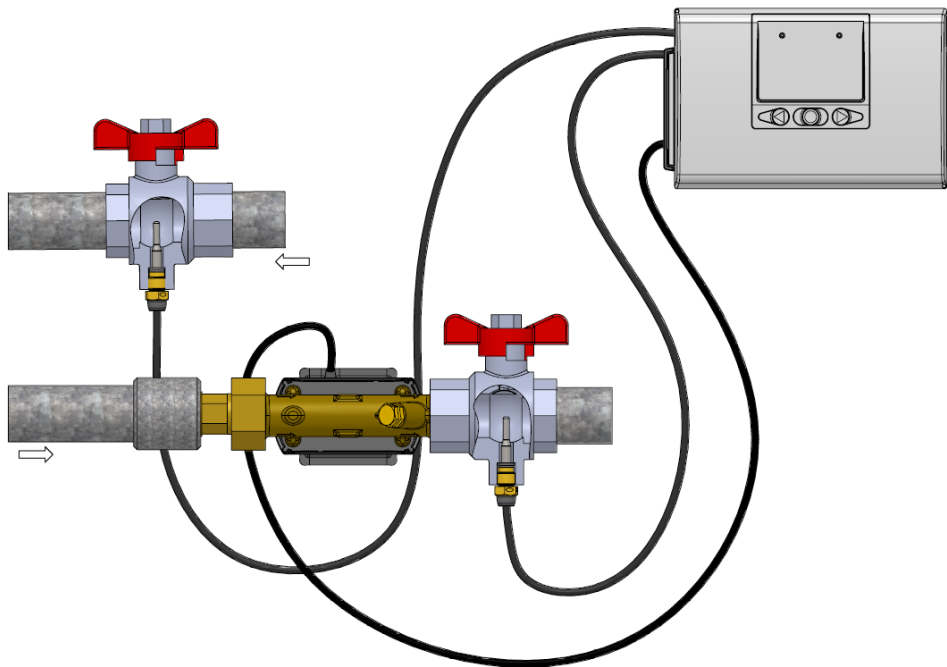

2 Resistance temperature sensors

In this chapter, the basis for the use of resistance temperature sensors, including the correlation between temperature and resistance, measuring principles, the design of temperature sensors as well as applied resistances, is described. The chapter also contains resistance tables for Pt100 and Pt500 temperature sensors.

2.1 The correlation between temperature and electrical resistance

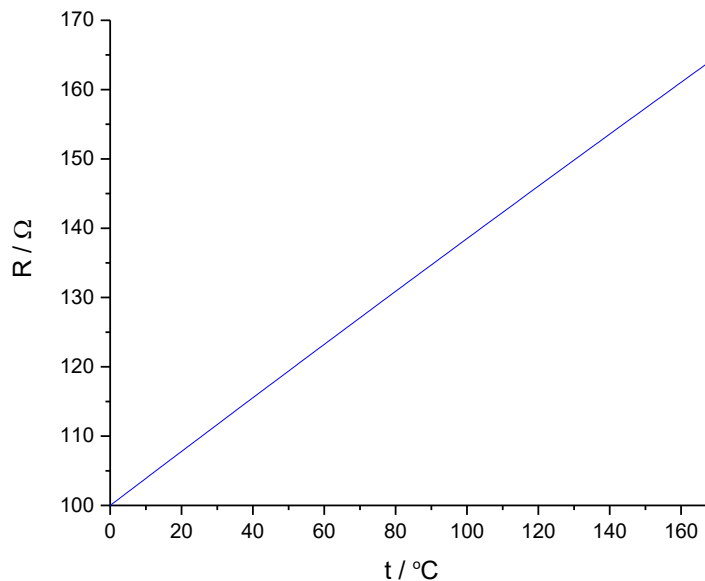

Figure 1: The correlation between the temperature, t , and the resistance, R , for a platinum Pt100 resistance temperature sensor with a resistance of $100\ \Omega$ at $0\ ^\circ\text{C}$.

A platinum resistance temperature sensor utilizes that the precious metal platinum has a very well-defined correlation between its electrical resistance and the temperature. An example of this is shown in *Figure 1*. On this basis, an international standard, EN 60751 (DIN/IEC 751) [2], has been established in which the correlation between the resistance R_t and the temperature t is defined by:

$$R_t = R_0(1 + At + Bt^2)$$

and where R_0 indicates the resistance at $0\ ^\circ\text{C}$ while A and B are constants.

The temperature t can then be defined by means of the following expression:

$$t = \frac{-R_0A + \sqrt{(R_0A)^2 - 4R_0B(R_0 - R_t)}}{2R_0B}$$

The nominal resistance is the expected resistance at $0\ ^\circ\text{C}$, and the most common nominal resistances within heat and cooling meters are $100\ \Omega$, $500\ \Omega$ and $1000\ \Omega$. Resistance temperature sensors are designated on the basis of the nominal resistance and the applied metal, Pt, and platinum resistance temperature sensors with nominal resistances of $100\ \Omega$, $500\ \Omega$ and $1000\ \Omega$, respectively, are thus designated as Pt100, Pt500 and Pt1000, respectively.

For an ideal Pt100 temperature sensor, it applies that $R_0 = 100,00\ \Omega$, $A = 3,9083 \cdot 10^{-3}\ ^\circ\text{C}^{-1}$ and $B = -5,775 \cdot 10^{-7}\ ^\circ\text{C}^{-2}$, and tables with examples of the correlation between temperature and resistance for ideal Pt100 and Pt500 temperature sensors can be found in paragraph 2.4. The exact values of R_0 , A and B for the individual temperature sensor will differ from temperature sensor to temperature sensor and are thus defined as a part of the legal verification of a temperature sensor for a heat and cooling meter, see paragraph 5.2.

2.2 Measuring principles and design of temperature sensors

In practice, a resistance temperature sensor functions by sending a small constant current through the resistance and then measuring the voltage drop U . The size of the platinum resistance R can then be determined by means of Ohm's law:

$$R = \frac{U}{I}$$

This is illustrated in *Figure 2*.

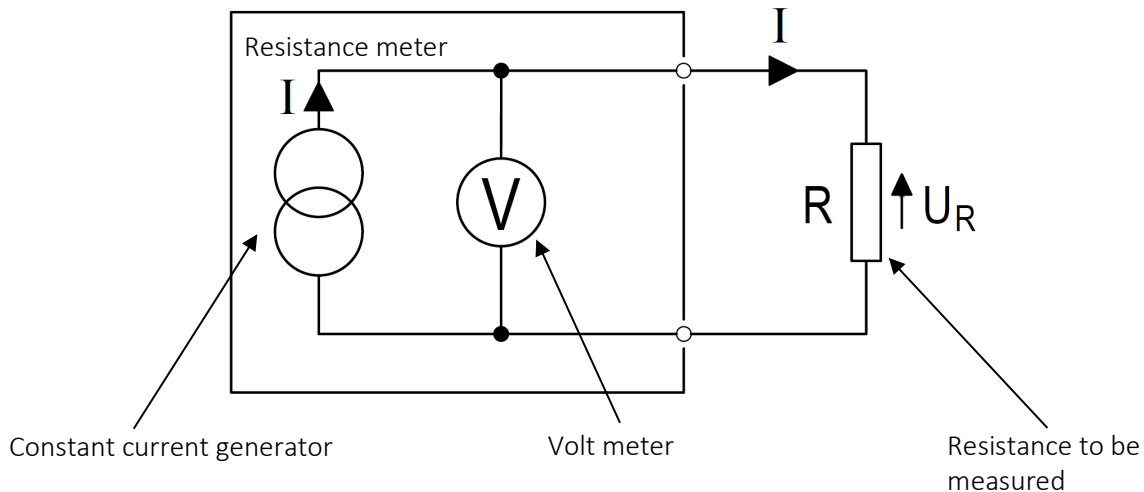

Figure 2: Measurement of a resistance value by means of a constant current ger

2.2.1 2-wire temperature measurement

As shown in *Figure 3*, a 2-wire temperature sensor is characterized by having two wires leading from the platinum resistance to the current generator and the measurement of the voltage drop. It applies for a 2-wire temperature sensor that the resistance of the wires also contributes to the measured resistance as they are in serial connection with the platinum resistance. The measured resistance R_m is thus

$$R_m = R + 2 \times R_w$$

where R_w is the resistance of the individual wires.

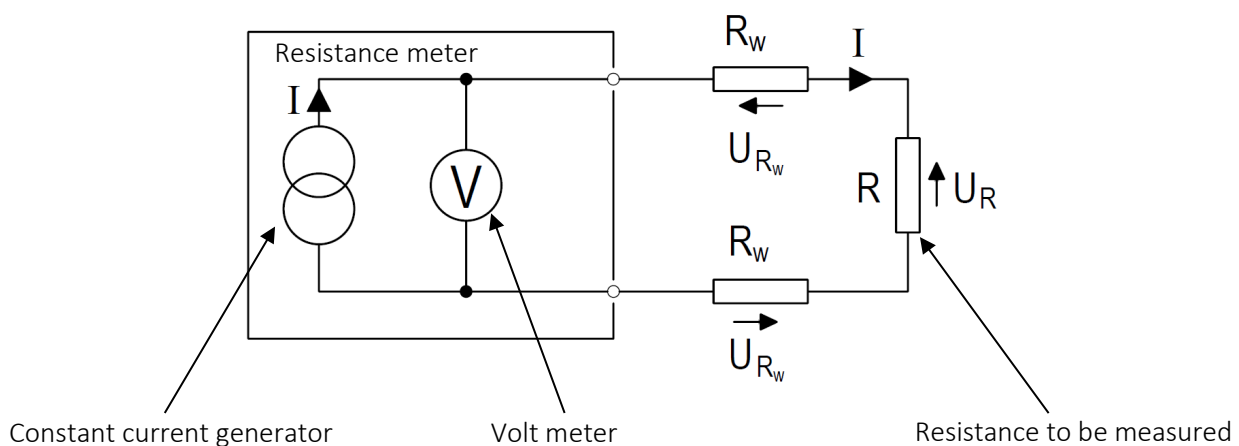

Figure 3: The influence of the wires on the measured resistance value.

As you are often interested in determining the temperature difference between two temperature sensors with great accuracy, you can compensate for the influence of the wires by requiring that all wires are equally long, see paragraph 5.4.

Temperature sensors

2.2.2 4-wire temperature measurement

A 4-wire temperature sensor functions by having 4 wires leading from the platinum resistance of which 2 wires are connected to the current generator and 2 wires are connected to the measurement of the voltage drop, see *Figure 4*. With a high-impedance volt meter, only the voltage drop U_R above the platinum resistance is now measured, and as the current is still I , the platinum resistance R is determined by:

$$R = \frac{U_R}{I}$$

In this way, it is ensured that only the resistance of the temperature sensor is measured, and that the temperature measurement is independent of the resistance of the wires.

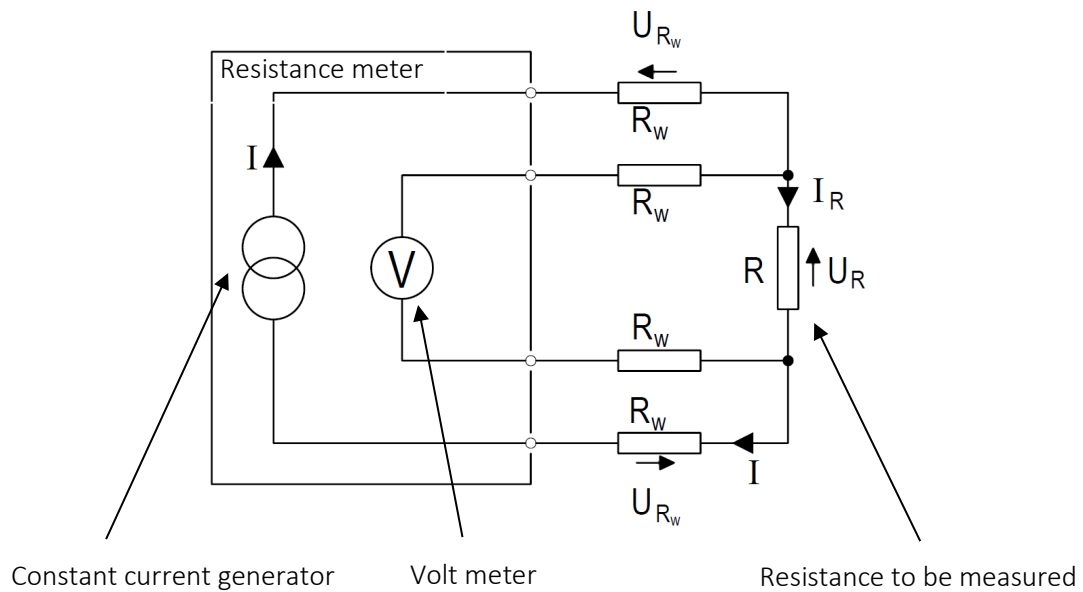

Figure 4: Measurement of resistance value by means of the 4-wire principle by which the wires do not influence the resistance measurement.

2.3 Applied types of resistance elements

For temperature sensors for heat and cooling meters, thin film resistors are most commonly used. Among other things, this is due to the fact that thin film resistors are affordable to produce, they do not take up much space, and they react very quickly to temperature changes. The most common solution is a thin film resistor that is mounted on a printed circuit board (PCB). Examples of this type of solution are shown in *Figure 5*. This solution has several advantages. First, it can be mass-produced, thereby reducing costs. Second, two soldering pads are placed on the same PCB on which the 2 wires used for a 2-wire temperature sensor can be soldered directly. This enables the production of 2-wire temperature sensors to be more efficient. Thin film resistors mounted on a PCB can typically be used at a temperature of up to 150 °C, which is sufficient in most installations.

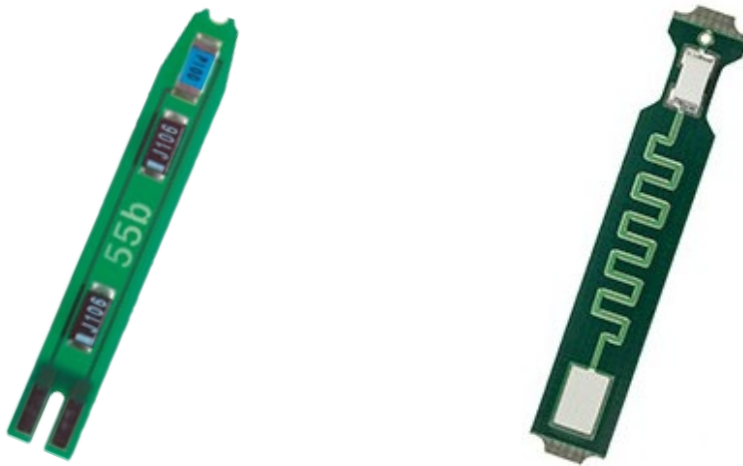

Figure 5: Thin film resistors mounted on a printed circuit board (PCB) [3,4].

If the temperature sensor is to be used at a higher temperature, e.g. 180 °C, thin film resistors mounted on a ceramic element are used. See *Figure 6*.



Figure 6: Thin film resistors mounted on a ceramic element [4,5].

Temperature sensors

2.4 Resistance tables

Pt100										
°C	0	1	2	3	4	5	6	7	8	9
0	100,000	100,391	100,781	101,172	101,562	101,953	102,343	102,733	103,123	103,513
10	103,903	104,292	104,682	105,071	105,460	105,849	106,238	106,627	107,016	107,405
20	107,794	108,182	108,570	108,959	109,347	109,735	110,123	110,510	110,898	111,286
30	111,673	112,060	112,447	112,835	113,221	113,608	113,995	114,382	114,768	115,155
40	115,541	115,927	116,313	116,699	117,085	117,470	117,856	118,241	118,627	119,012
50	119,397	119,782	120,167	120,552	120,936	121,321	121,705	122,090	122,474	122,858
60	123,242	123,626	124,009	124,393	124,777	125,160	125,543	125,926	126,309	126,692
70	127,075	127,458	127,840	128,223	128,605	128,987	129,370	129,752	130,133	130,515
80	130,897	131,278	131,660	132,041	132,422	132,803	133,184	133,565	133,946	134,326
90	134,707	135,087	135,468	135,848	136,228	136,608	136,987	137,367	137,747	138,126
100	138,506	138,885	139,264	139,643	140,022	140,400	140,779	141,158	141,536	141,914
110	142,293	142,671	143,049	143,426	143,804	144,182	144,559	144,937	145,314	145,691
120	146,068	146,445	146,822	147,198	147,575	147,951	148,328	148,704	149,080	149,456
130	149,832	150,208	150,583	150,959	151,334	151,710	152,085	152,460	152,835	153,210
140	153,584	153,959	154,333	154,708	155,082	155,456	155,830	156,204	156,578	156,952
150	157,325	157,699	158,072	158,445	158,818	159,191	159,564	159,937	160,309	160,682
160	161,054	161,427	161,799	162,171	162,543	162,915	163,286	163,658	164,030	164,401
170	164,772	165,143	165,514	165,885	166,256	166,627	166,997	167,368	167,738	168,108
180	168,478	168,848	169,218	169,588	169,958	170,327	-	-	-	-

Table 1: Pt100, IEC 751 Amendment 2-1995-07

Pt500										
°C	0	1	2	3	4	5	6	7	8	9
0	500,000	501,954	503,907	505,860	507,812	509,764	511,715	513,665	515,615	517,564
10	519,513	521,461	523,408	525,355	527,302	529,247	531,192	533,137	535,081	537,025
20	538,968	540,910	542,852	544,793	546,733	548,673	550,613	552,552	554,490	556,428
30	558,365	560,301	562,237	564,173	566,107	568,042	569,975	571,908	573,841	575,773
40	577,704	579,635	581,565	583,495	585,424	587,352	589,280	591,207	593,134	595,060
50	596,986	598,911	600,835	602,759	604,682	606,605	608,527	610,448	612,369	614,290
60	616,210	618,129	620,047	621,965	623,883	625,800	627,716	629,632	631,547	633,462
70	635,376	637,289	639,202	641,114	643,026	644,937	646,848	648,758	650,667	652,576
80	654,484	656,392	658,299	660,205	662,111	664,017	665,921	667,826	669,729	671,632
90	673,535	675,437	677,338	679,239	681,139	683,038	684,937	686,836	688,734	690,631
100	692,528	694,424	696,319	698,214	700,108	702,002	703,896	705,788	707,680	709,572
110	711,463	713,353	715,243	717,132	719,021	720,909	722,796	724,683	726,569	728,455
120	730,340	732,225	734,109	735,992	737,875	739,757	741,639	743,520	745,400	747,280
130	749,160	751,038	752,917	754,794	756,671	758,548	760,424	762,299	764,174	766,048
140	767,922	769,795	771,667	773,539	775,410	777,281	779,151	781,020	782,889	784,758
150	786,626	788,493	790,360	792,226	794,091	795,956	797,820	799,684	801,547	803,410
160	805,272	807,133	808,994	810,855	812,714	814,574	816,432	818,290	820,148	822,004
170	823,861	825,716	827,571	829,426	831,280	833,133	834,986	836,838	838,690	840,541
180	842,392	844,241	846,091	847,940	849,788	851,635	-	-	-	-

Table 2: Pt500, IEC 751 Amendment 2-1995-07

3 Temperature sensors for heat and cooling meters

In this chapter, the most commonly used temperature sensors for heat and cooling meters are reviewed. In practice, a wide range of temperature sensors are used for heat and cooling meters, and the choice of temperature sensor typically depends on the installation in which the heat or cooling meter is to be installed. Basically, a distinction is made between a direct temperature sensor, which is in direct contact with the fluid flow, and a pocket sensor where a pocket, typically of stainless steel, is installed in the fluid flow after which the temperature sensor is installed in the pocket.

Figure 7 shows a direct temperature sensor and a pocket sensor. For clarity purposes, this chapter is divided into a paragraph about the most commonly used 2-wire temperature sensors and a paragraph about 4-wire temperature sensors.

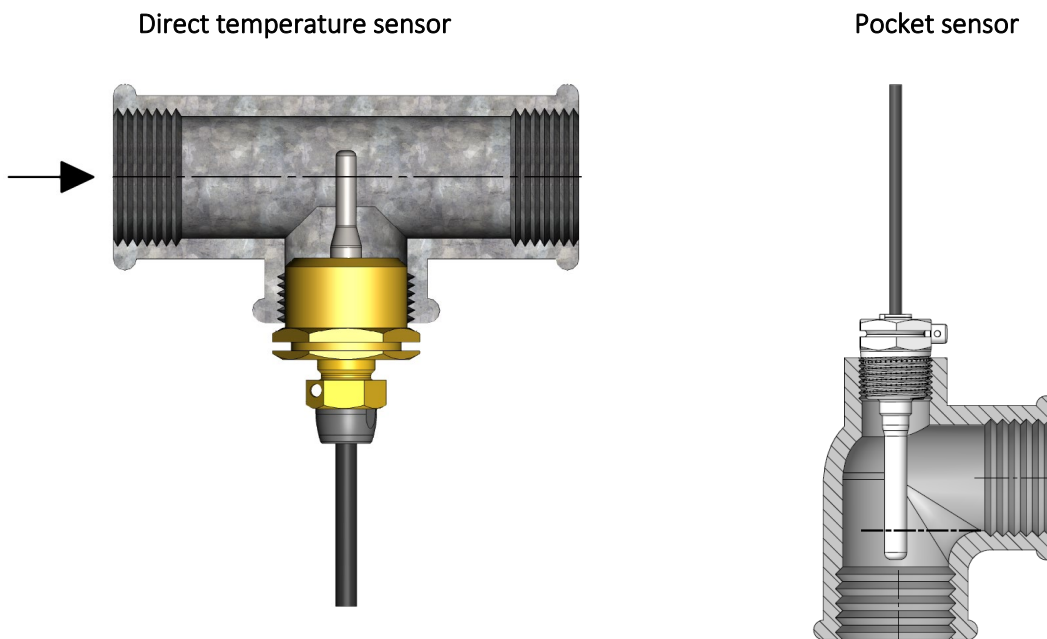

Figure 7: Illustration of a direct temperature sensor and a pocket sensor.

3.1 2-wire temperature sensors

For heat and cooling meters, 2-wire temperature sensors are by far the most common compared to 4-wire temperature sensors. This is due to the lower price for both a 2-wire temperature sensor and the related 2-wire calculator. As a two-wire temperature sensor set must have equally long cables, see paragraph 5.4, there is also the difference that a 2-wire temperature sensor is typically mounted in the calculator at the factory, while a 4-wire temperature sensor is usually first installed in the calculator when the heat or cooling sensor is installed. In the following paragraph, the most common types of 2-wire temperature sensors are reviewed.

Temperature sensors

3.1.1 Direct short temperature sensor

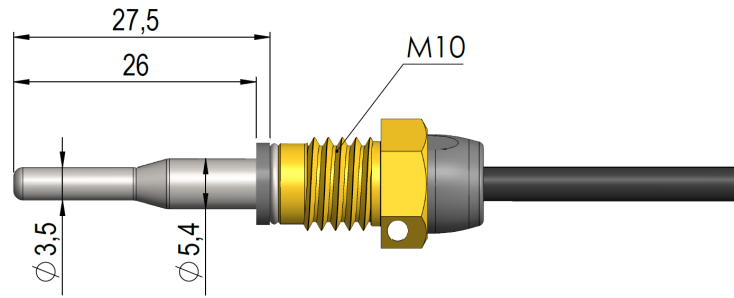

Figure 8: Direct short DS 27,5 mm temperature sensor.

The direct short temperature sensor has been designed according to the European standard for heat energy meters EN 1434-2 [1]. The most common variant has an immersion depth of 27,5 mm and is therefore called DS 27,5 mm where DS stands for “Direct Short”. Similarly, a 38 mm immersion depth variant is available, called DS 38 mm. The DS 27,5 mm temperature sensor is shown in Figure 8. The application options of the DS 27,5 mm and DS 38 mm temperature sensors are shown in Table 3. The direct short temperature sensor is characterized by a very short response time, see paragraph 4.1, due to the fact that the tip of the temperature sensor has a relatively small diameter of $\phi 3,5$ mm and is in direct contact with the fluid flow. This makes it the preferred temperature sensor for heat and cooling meters used in DN 15 to DN 40 installations. Especially for meters installed in district heating units, the selection of a direct short temperature sensor has a major impact on the correct energy measurement due to the rapid changes in the temperature caused by a district heating unit.

DN	DS 27,5 mm	DS 38 mm
15	X	
20	X	
25	X	
32		X
40		X

Table 3: The application options of the DS 27,5 mm and DS 38 mm temperature sensors.

3.1.2 Pocket sensors

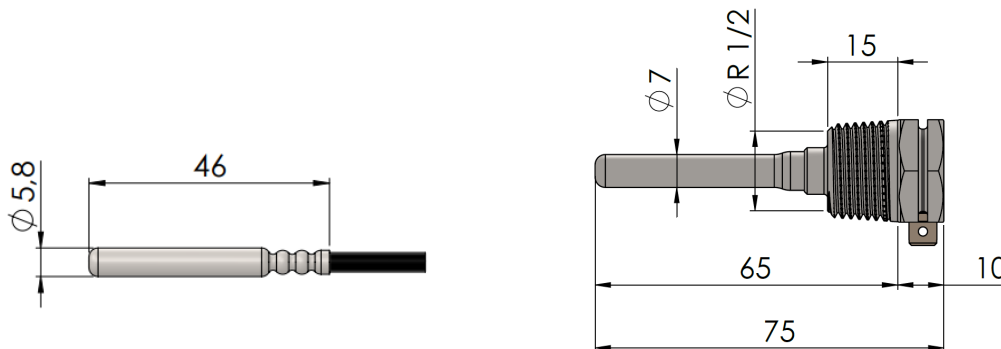

Figure 9: $\phi 5,8$ mm pocket sensor with corresponding 65 mm pocket.

In Figure 9, an example of a pocket sensor and a corresponding stainless steel pocket is shown. The great advantage of mounting a temperature sensor in a pocket is that the temperature sensor can be replaced afterwards without having to shut off the water. Pocket sensors are thus most often used in conjunction with larger meters, e.g. in a distribution network. A pocket sensor mounted in a pocket has the disadvantage that the total mass is larger and therefore reacts more slowly to temperature changes, which may affect the measured amount of heat energy. For more details on the response time, see paragraph 4.1.

The temperature sensor illustrated in *Figure 9* has a diameter of $\varnothing 5,8$ mm. Pocket sensors with diameters of $\varnothing 5,0$ mm, $\varnothing 5,2$ mm and $\varnothing 6,0$ mm are also used for heat and cooling meters. In this connection, it is worth pointing out that the pocket used must have an inner diameter that fits the diameter of the pocket sensor. In practice, this is clarified by the fact that pocket sensor and pocket must be approved for use together. For the $\varnothing 6,0$ mm temperature sensor, which is designed according to EN1434-2, it is particular that this temperature sensor may be used in all approved pockets for $\varnothing 6,0$ mm temperature sensors that are also designed according to EN1434-2, regardless of the manufacturer. The relevant pockets for $\varnothing 6,0$ mm temperature sensors are characterised by being marked with “EN1434”.

Pocket sensors with a diameter of $\varnothing 5,0$ mm and $\varnothing 5,2$ mm can typically be used as direct temperature sensors when mounting a union, e.g. in a ball valve, see *Figure 10*. This gives a great flexibility in the installation type as the temperature sensor can be installed as both a direct temperature sensor and a pocket sensor.

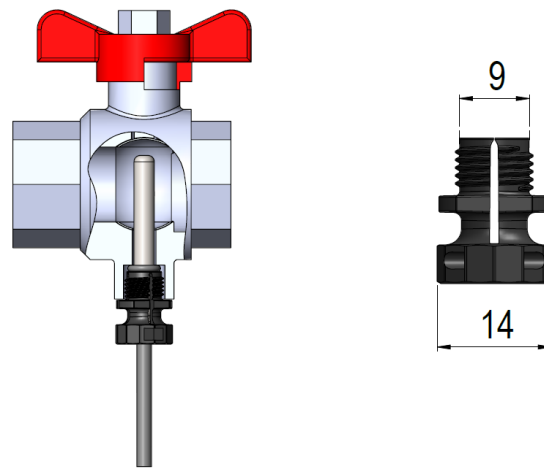

Figure 10: $\varnothing 5,2$ mm temperature sensor with composite union mounted in a ball valve.

3.2 4-wire temperature sensors

Contrary to 2-wire temperature sensors, it applies to 4-wire temperature sensors that the resistance of the cable does not affect the temperature measurement, see paragraph 2.2.2. This means that a more precise temperature measurement is obtained by using 4-wire temperature sensors. 4-wire temperature sensors are thus typically used in large installations where an improved temperature measurement offers greater opportunities for optimising the operational conditions and with it the production costs. At the same time, 4-wire temperature sensors also provide great flexibility when it comes to cable routing optimization as it is not required for 4-wire sensors that the cables are equally long. As it in large installations is necessary to be able to replace the temperature sensor without closing the water flow, 4-wire temperature sensors are mainly used as pocket sensors. In the following paragraph, the most common types of 4-wire temperature sensors are reviewed.

Temperature sensors

3.2.1 $\varnothing 5,8$ mm pocket sensor with connection head

The $\varnothing 5,8$ mm pocket sensor with connection head is characterized by a replaceable temperature sensor insert on which a 2-wire $\varnothing 5,8$ mm pocket sensor is soldered. The temperature sensor insert is mounted in a stainless steel pocket with connection head, see *Figure 11*. The connection head is deliberately placed outside the insulation of the pipe and is thus easily accessible. Connection of 4-wire cable takes place by inserting the cable through the PG coupling and installing the 4 wires in the screw terminal on the temperature sensor insert.

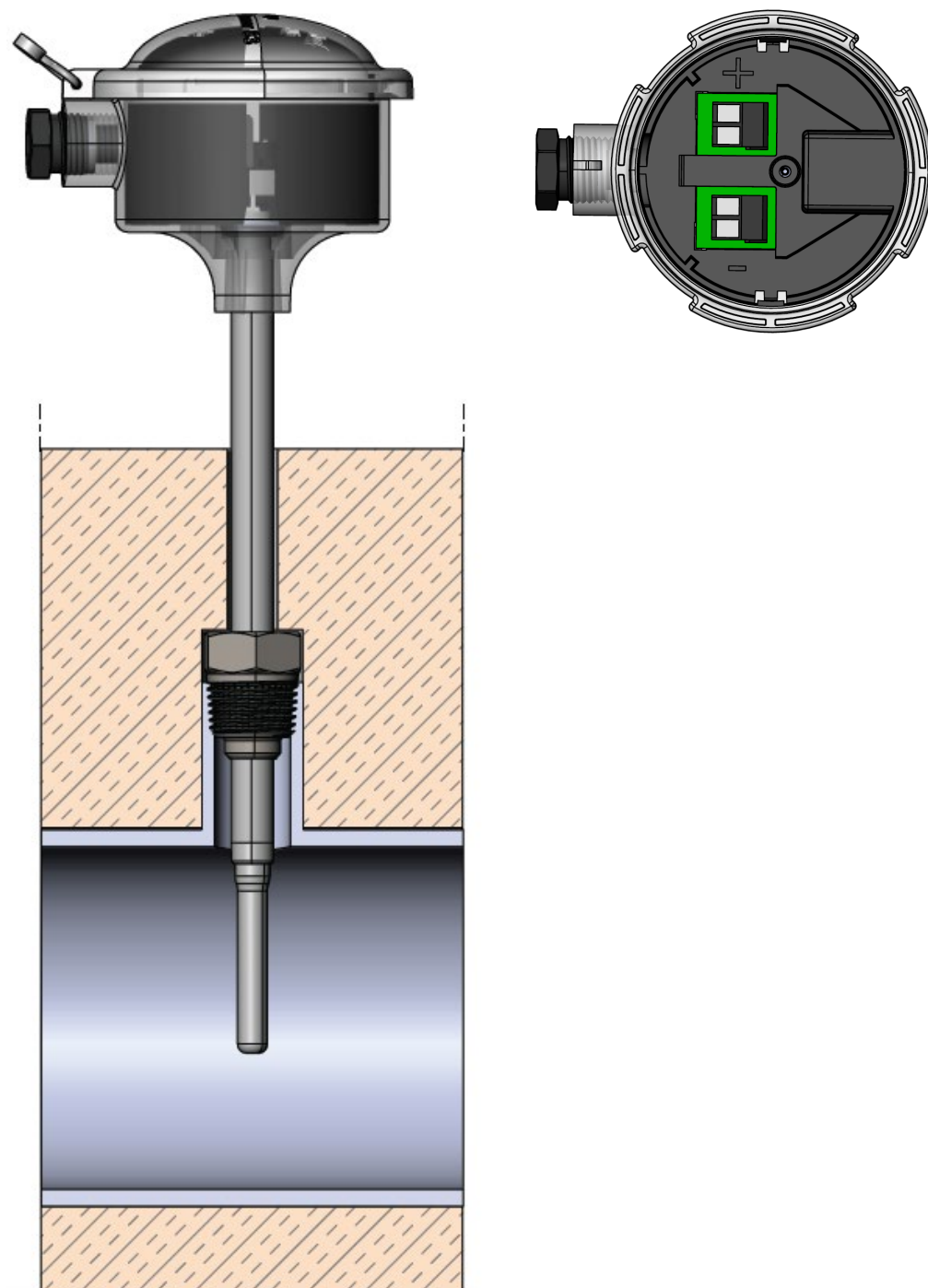

Figure 11: $\varnothing 5,8$ mm pocket sensor with connection head mounted in an insulated pipe.

3.2.2 $\varnothing 6,0$ mm pocket sensor with connection head

Contrary to the $\varnothing 5,8$ mm pocket sensor with connection head, it applies to a $\varnothing 6,0$ mm pocket sensor with connection head that the temperature sensor and pocket are completely separated, as shown in *Figure 12*. For this temperature sensor, both the diameter and the length are defined in the EN 1434-2 standard [1]. The connection head itself is available in several designs and one of the most common designs is the connection head shown in *Figure 12*, which is made of aluminium and of the type DIN Form B. This temperature sensor is also available with a thin film resistor fitted with a ceramic element, which means that it can be used at temperatures as high as 180 degrees, see paragraph 2.3. For flow rates up to 3 m/s, a welded stainless steel pocket with a diameter of $\varnothing 8$ mm at the tip is used. At flow rates above 3 m/s, a stainless steel pocket with a diameter of $\varnothing 10$ mm at the tip, see *Figure 12*, and made of one piece is used. For more information on selecting pockets at high flow rates and/or high temperatures, see paragraph 6.5.

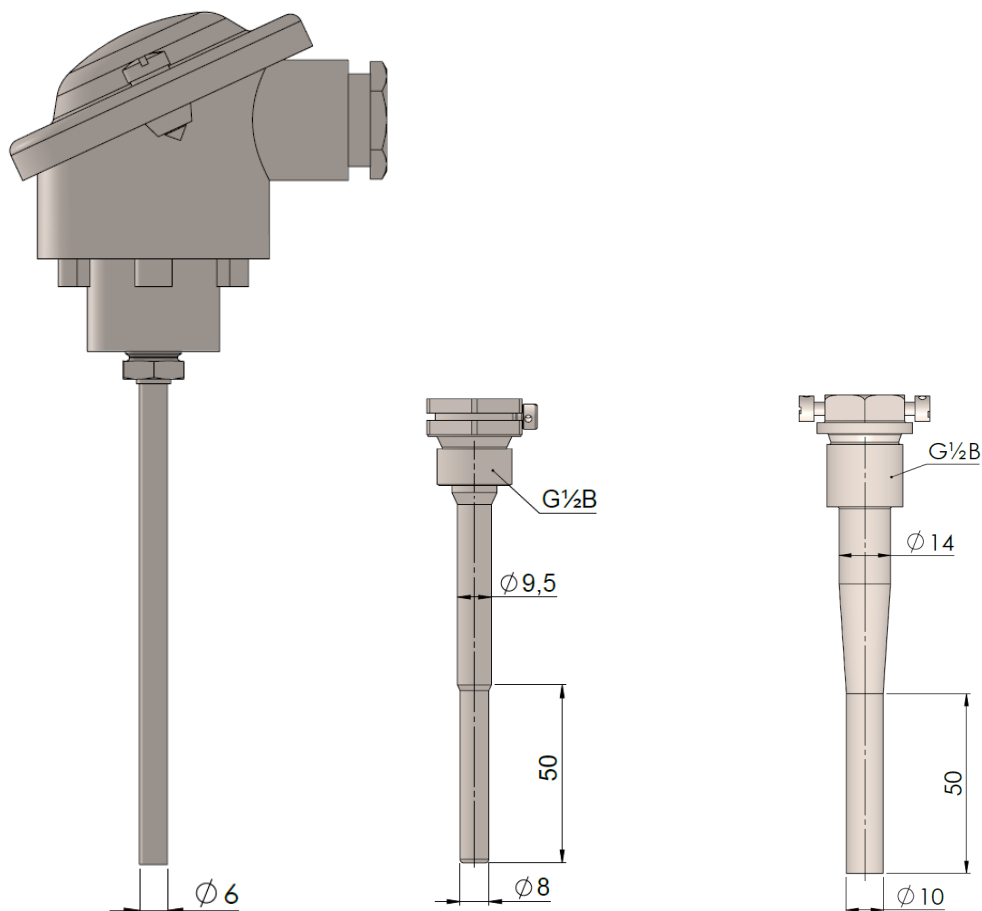

Figure 12: $\varnothing 6,0$ mm pocket sensor with connection head and corresponding pockets.

4 Terminology for temperature sensors used in energy measurement

This chapter discusses the key terms of temperature sensors used in energy measurement, including the terms response time, heat discharge error and qualifying immersion depth.

4.1 Response time

The response time of a temperature sensor is a measure of how quickly a temperature sensor responds to a given temperature change. Especially for heat meters mounted in district heating units with tap water exchanger, a short response time is important as in this case frequent and short-term temperature changes are occurring. If a temperature sensor with a long response time is used in this application situation, the heat meter will detect a consumption lower than the actual consumption.

The response time $\tau_{0.5}$ is defined as the time it takes for the temperature sensor to detect half of a given temperature change. In *Figure 13*, an example is shown of how a direct short temperature sensor responds to a temperature change from $t_1=23\text{ °C}$ to $t_2=33\text{ °C}$. The temperature change starts at the time of τ_1 and at the time of τ_2 , half of the temperature change has been detected. The response time $\tau_{0.5}$ may then be determined by the following calculation:

$$\tau_{0.5} = \tau_2 - \tau_1$$

In the example in *Figure 13*, the response time $\tau_{0.5}$ of the direct short temperature sensor concerned is determined to be 1.7 s.

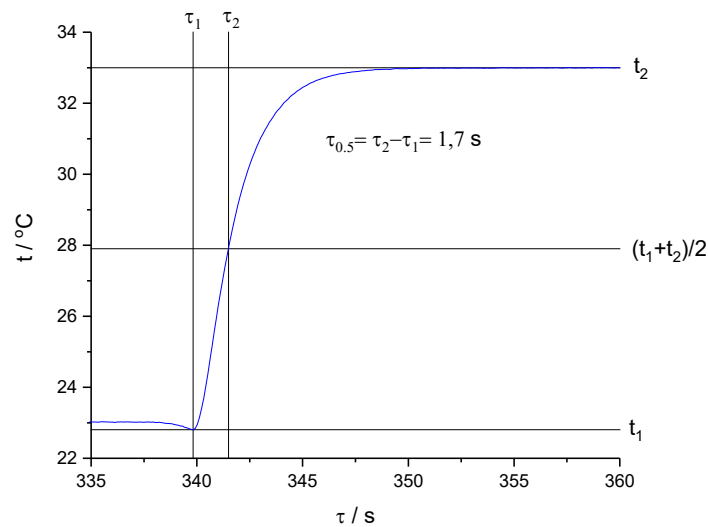

Figure 13: Measurement of the response time of a direct short temperature sensor.

In practice, the response time is measured by placing the temperature sensor in a cold thermostatic bath, which typically has the same temperature as the surroundings, e.g. 23 °C, and then quickly moving the temperature sensor into a warmer thermostatic bath with a temperature of, for example, 33 °C. In this way, the temperature sensor experiences a temperature change of 10 K. This is illustrated in *Figure 14*.

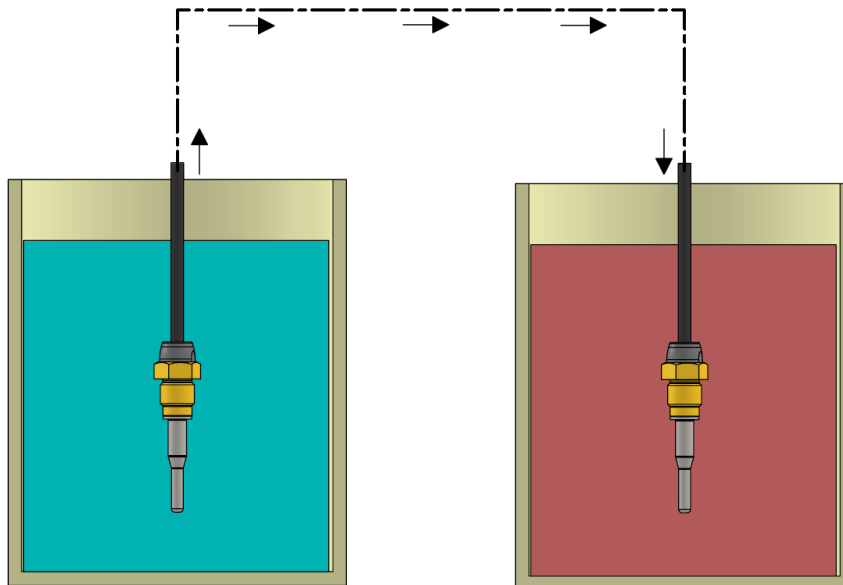

Figure 14: Illustration of the setup for measurement of response time for a temperature sensor where the temperature sensor is moved from one thermostatic bath to another thermostatic bath. The temperature difference between the two baths is typically 10 K.

As a starting point, the response time is assumed to be the same for all temperature changes. If there is a significant heat conduction error, see paragraph 4.2, the response time will be affected by the ambient temperature in such a way that an increased response time will be observed if temperature changes lead to a temperature rise significantly higher than the ambient temperature. Similarly, at a temperature drop from a relatively high temperature to around the ambient temperature, a shortened response time will be observed.

The response time of a temperature sensor depends on its design. In general, direct temperature sensors typically have a short response time as they are in direct contact with the fluid, while the response time is longer for a pocket sensor. In *Table 4*, the typical response times for a number of temperature sensors used for heat and cooling meters are shown.

	Response time
Direct short DS 27,5 mm temperature sensor	2 s
∅5,2 mm direct temperature sensor with fitted union	3 s
∅5,8 mm pocket sensor mounted in a 65 mm pocket	8 s
∅6,0 mm pocket sensor with connection head mounted in an 85 mm standard pocket	12 s
∅6,0 mm pocket sensor with connection head mounted in a 120 mm reinforced pocket	16 s

Table 4: Typical response times for both direct temperature sensors and pocket sensors mounted in pockets.

4.2 Heat conduction error

In connection with heat and cooling meters, it is ideal to measure the true temperature of the water in the inlet pipe and outlet pipe, respectively. In heat meters, the temperatures in both the inlet and outlet flows will be higher than the ambient temperature. As shown in *Figure 15*, this temperature difference can lead to a heat conduction into the surroundings, also known as a heat conduction error. The heat conduction into the surroundings causes the temperature sensor to not measure the correct temperature inside the pipe. Basically, the temperature sensor is designed in such a way that the heat conduction error is minimized. Sensor pockets have a larger mass than direct sensors, and this also implies a larger heat discharge for pocket sensors than for direct sensors. In general, a long temperature sensor has a smaller heat conduction error than a corresponding shorter temperature sensor as a larger proportion of the long temperature sensor is immersed in the fluid, see paragraph 4.3. The greatest heat conduction error is thus seen when using pocket sensors in short pockets with a length of 35 to 50 mm, and these pockets can therefore typically only be approved for use in a temperature range lower than the maximum of 150 degrees for which temperature sensors are normally approved.

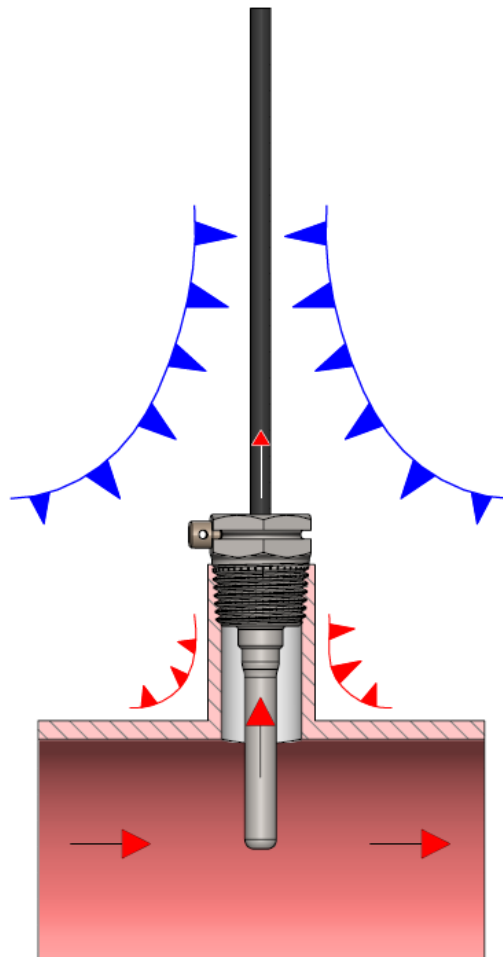

Figure 15: Illustration of heat conduction error in temperature measurement due to heat conduction into the surroundings.

4.3 Qualifying immersion depth

Qualifying immersion depth is a measure of how many millimetres the temperature sensor must be immersed into the fluid to ensure that the heat conduction from the temperature sensor causes a maximum heat conduction error of 0.1 K at 85 °C. The size of the heat conduction error is determined by first immersing two temperature sensors in a thermostatic bath so that they are initially completely immersed in water and thus measure the same temperature. Then one temperature sensor is partially removed from the bath, while the other temperature sensor is still completely immersed in water, see *Figure 16*. Due to the heating conduction error of the partially immersed temperature sensor, the two temperature sensors now measure two different temperatures. The heat conduction error is found by determining the temperature difference between the two temperature sensors. The qualifying immersion depth of a given temperature sensor depends on the design of the temperature sensor. For example, a DS 27,5 mm temperature sensor with an outer diameter of $\varnothing 3,5$ mm will have a smaller qualifying immersion depth than a pocket sensor with a diameter of $\varnothing 5,8$ mm. As further described in paragraph 3.1.1, the EN 1434 standard contains a number of design requirements for a direct short temperature sensor, including that the qualifying immersion depth must not exceed 20 mm.

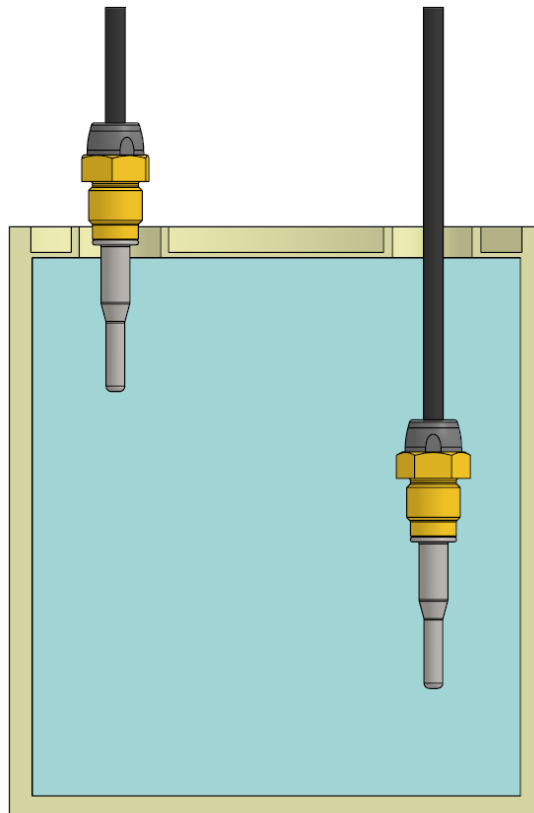

Figure 16: The qualifying immersion depth is determined by comparing the measurements of two temperature sensors that are fully and partially immersed in water, respectively.

The difference between the two temperature sensors must not exceed 0,1 K.

5 Regulatory requirements for marketed temperature sensors

A wide range of regulatory requirements apply to temperature sensors that are marketed for heat and cooling meters. This is because heat and cooling meters are used for billing between two parties. This chapter reviews the main regulatory requirements, including type approval, measurement and verification as well as requirements for temperature sensor sets, cables and marking.

5.1 Type approval

In most EU and EEA countries, it is a legal requirement that temperature sensors for heat meters have a type approval before they can be used for legal billing. This type approval is issued on the basis of the EU directive Measuring Instruments Directive (MID), 2014/32/EU, which at EU level determines the rules for measuring equipment to be used for legal billing. Compared to earlier where each country issued a national authorization, today it is only necessary to receive one MID authorization after which the temperature sensors can be used for legal billing in all EU and EEA countries. In each participating country, a notified body has been designated, which is authorized to issue MID approvals. For temperature sensors, the majority of the MID approvals have been issued by either FORCE Certification in Denmark, PTB in Germany or BEV in Austria.

To obtain a type approval, temperature sensors are required to conform to the harmonized version of the EN1434 standard, among other things. This is demonstrated by a number of type tests, which are also designed based on the EN1434-4 standard [1]. Examples of type tests are the determination of response time and the qualifying immersion depth, see the paragraphs 4.1 and 4.3.

Cooling meters are not part of the MID directive and therefore, common European rules do not apply to cooling meters for use in billing. A number of countries have thus introduced national type approvals in this field, including Denmark, Germany, Austria and Switzerland. The requirements for obtaining a national cooling approval vary from country to country, but a general feature is that the temperature sensors for cooling meters must comply with the EN 1434 standard. In some areas, the EN 1434 standard contains extended requirements for temperature sensors to be used with cooling meters. For example, temperature sensors for use with cooling meters must be subjected to an extended type test program to ensure that the temperature sensors are capable of meeting the specific challenges of condensation that may arise in cooling meter installations.





	
<h2 style="margin: 0;">EU-Type Examination Certificate</h2> <h3 style="margin: 0;">Measuring Instrument Directive</h3>	
<p>Certificate number: DK-0200-MI004-046 Issued by FORCE Certification A/S, Denmark EU-notified body number 0200</p>	
<p>In accordance with Annex II Module B of the Directive 2014/32/EU of the of the European Parliament and of the Council of 26 February 2014 on the harmonization of the laws of the Member States relating to the making available on the market of measuring instruments (MID).</p>	
<p>Issued to:</p>	<p>Kamstrup A/S Industrivej 28, Stilling DK-8660 Skanderborg Denmark</p>
<p>Type of instrument:</p>	<p>Thermal energy meter, temperature sensor pair</p>
<p>Type designation:</p>	<p>Kamstrup TemperatureSensor 63 and Kamstrup TemperatureSensor 83</p>
<p>Valid until:</p>	<p>2031-02-03</p>
<p>Number of pages:</p>	<p>14, including appendix</p>
<p>Date of issue:</p>	<p>2023-03-01</p>
<p>Version:</p>	<p>1 This new version of DK-0200-MI004-046 is issued due to a new EN 1434 edition, OIML R 75, fast response meter, pocket 65-57-349 and minor editorial changes. The previous certificate is withdrawn.</p>
<p>Approved by</p>	<p>Processed by</p>
<p> Michael Møller Nielsen Certification Manager</p>	<p> Lars Poder Examiner</p>
<p>The conformity markings may only be affixed to the above type approved equipment. The manufacturer's Declaration of Conformity may only be issued and the notified body identification number may only be affixed on the instrument when the production/product assessment module (D or F) of the directive is fully complied with and controlled by a written inspection agreement with a notified body. This EU-type examination certificate may not be reproduced except in full, without written permission by FORCE Certification A/S.</p>	
<p>FORCE Certification references: TASK No.: 120-36087.02 and ID No.: 0200-MID-09852-2</p>	
<p><small>FORCE Certification A/S · Park Allé 345 · 2605 Brøndby · Denmark · Tel +45 43 25 01 77 · Fax +45 43 25 00 10 · info@forcecertification.com · www.forcecertification.com</small></p>	
<p>Page 1 of 14</p>	

Figure 17: An example of a MID approval for temperature sensors issued by FORCE Certification.

5.2 Measurement and verification

A temperature sensor must be measured at three different test temperatures before R_0 , A and B (see paragraph 2.1) can be determined. The requirements for the three test temperatures are described in EN 1434. If a temperature sensor is to be used for the temperature range of 2...150 °C, it is typically tested at 10 °C, 75 °C and 140 °C in special thermostatic baths, which have been designed for this purpose. In each thermostatic bath, a reference thermometer is placed, which measures the temperature t_i in the bath. Then the resistance value R_i of the temperature sensor is measured. By measuring in three different baths, the three resistance values R_1 , R_2 , R_3 and the three corresponding temperatures t_1 , t_2 , t_3 are obtained. R_0 , A and B can then be determined by solving the following 3 equations with 3 unknown quantities:

$$R_1=R_0(1+At_1+Bt_1^2)$$

$$R_2=R_0(1+At_2+Bt_2^2)$$

$$R_3=R_0(1+At_3+Bt_3^2)$$

A temperature sensor for heat or cooling measurement must, as described in EN 1434-5 [1], not deviate more than 2 K from an ideal temperature sensor. When R_0 , A and B have been determined for a given temperature sensor, the next step in the verification is to carry out a check calculation to ensure that the temperature sensor complies with this requirement. An example of such a verification calculation is shown in *Figure 18*.

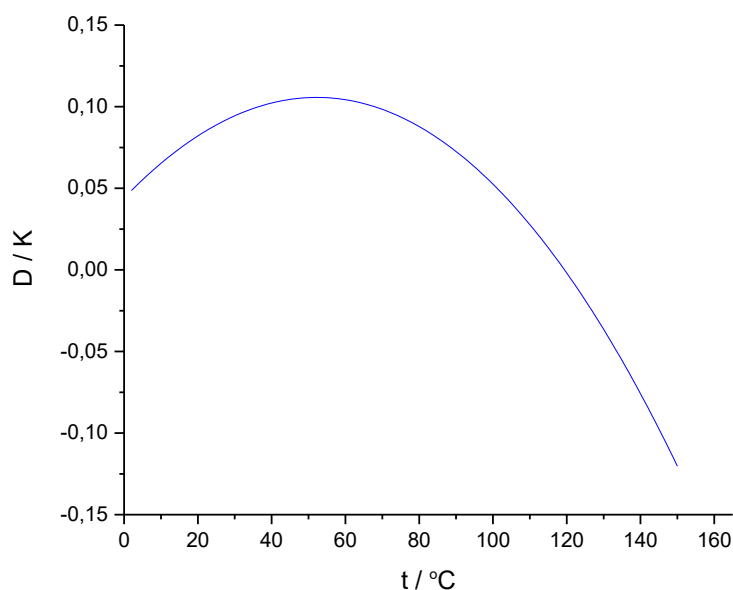

Figure 18: Example of a check calculation of a Pt500 temperature sensor where the deviation D from an ideal Pt500 temperature sensor is determined for all temperatures t in the temperature range 2-150 °C.

Then, as described in EN 1434, it is checked that the temperature sensor has sufficient insulation resistance. This is to ensure that there is no electrical transition inside the temperature sensor.

5.3 Requirements for temperature sensor set

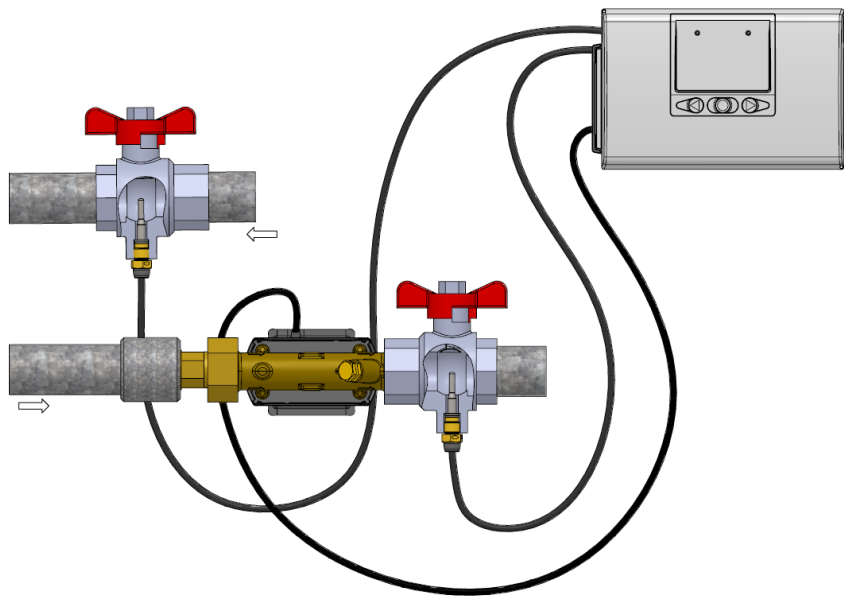

Figure 19: A typical heat or cooling meter installation in which one temperature sensor is installed in the inlet flow and the other one is installed in the outlet flow.

As shown in Figure 19, a correct energy calculation requires that the temperature difference between the inlet temperature and the outlet temperature is measured. Therefore, very strict requirements are imposed on how much the two temperature sensors in a given temperature sensor set may differ. The deviation in percent of the temperature difference, E_t , is defined in the EN 1434 standard and must maximum be:

$$E_t = \pm \left(0,5 + 3 \frac{\Delta\theta_{min}}{\Delta\theta} \right)$$

where $\Delta\theta$ is the temperature difference in question and $\Delta\theta_{min}$ is the smallest temperature difference approved.

The MID directive states that $\Delta\theta_{min}$ must be at least 3 K, which means that $\Delta\theta_{min}$ is most often 3 K.

In Table 5, the maximum allowable deviation for a differential temperature measurement with two temperature sensors is shown for a number of selected temperature differences at $\Delta\theta_{min} = 3$ K.

Temperature difference $\Delta\theta$	Maximum allowable deviation %	Maximum allowable deviation K
3 K	3,5 %	0,105 K
6 K	2,0 %	0,120 K
9 K	1,5 %	0,135 K
15 K	1,1 %	0,165 K
30 K	0,8 %	0,24 K
60 K	0,65 %	0,39 K

Table 5: The maximum allowable deviation in a differential temperature measurement with two temperature sensors for a number of temperature differences.

Temperature sensors

When pairing a given temperature sensor set, a number of calculations are made to ensure that any temperature sensor set complies with the limits set in the EN 1434 standard for the deviation between the two temperature sensors. For the Kamstrup Pt500 temperature sensors, the maximum deviation between the two temperature sensors in percent is typically:

$$E_t = \pm \left(0,4 + \frac{4}{\Delta\theta} \right)$$

This gives the following maximum typical deviation for the Kamstrup Pt500 temperature sensors:

Temperature difference $\Delta\theta$	Maximum typical deviation %	Maximum typical deviation K
3 K	1,7 %	0,052 K
6 K	1,1 %	0,064 K
9 K	0,84 %	0,076 K
15 K	0,67 %	0,10 K
30 K	0,53 %	0,16 K
60 K	0,47 %	0,28 K

Table 6: Maximum typical deviation between two Kamstrup Pt500 temperature sensors for a number of temperature differences.

5.4 Requirements for temperature sensor cables

As shown in paragraph 2.2.1, it applies to two-wire temperature sensors that the resistance of the cable affects the measured temperature. The EN 1434 standard therefore describes a number of sensor cable requirements used for 2-wire temperature sensors to ensure a correct energy calculation as possible. First, the cables must be equal in length as different cable lengths will cause an error in the calculation of the temperature difference. In continuation of this, EN 1434 also describes that the lengths of the sensor cables must not be subsequently changed.

The resistance of the temperature sensor cables changes with the temperature, which can cause a serious error in measuring the temperature difference if certain conditions are present in the form of long cables and small cable cross sections. In practice, the cable cross section is the area of the copper wires. Therefore, requirements for the maximum cable length for a given combination of the cable cross section and the nominal resistance have been introduced in EN 1434, as shown in *Table 7*.

Cable cross section	Max cable length for Pt100	Maximum cable length for Pt500
0.22 mm ² / 0.25 mm ²	2,5 m	12,5 m
0.50 mm ²	5,0 m	25,0 m
0.75 mm ²	7,5 m	37,5 m
1.50 mm ²	15,0 m	75,0 m

Table 7: Requirements in the EN 1434 standard for temperature sensor cables to be used for 2-wire temperature sensors.

However, for 4-wire temperature sensors, cables need not be of equal lengths as the resistance of the cables does not affect the temperature measurement. Similarly, the same requirements regarding a maximum cable length for a given combination of the cable cross section and nominal resistance are not demanded. The maximum cable length, however, depends on the calculator used (e.g. for EMC reasons). The MULTICAL® 603 and MULTICAL® 803 calculators are approved for use with up to 100 m 4-wire cable, e.g. of the type 4 x 0,25 mm².

5.5 Labelling of temperature sensors and pockets

As the temperature sensors and their pockets are used for legal billing, there are a number of requirements for proper labelling. Depending on the approval, there are different labelling requirements and the correct labelling thus always depends on the exact approval. The following examples of temperature sensor and pocket labelling are thus only to be seen as examples explaining the most commonly used labels in the labelling of temperature sensors and pockets.

Example of labelling of temperature sensor - front	
Type number	T/N: 61-63-D0-051-218
Permissible pressure stage	E _{abs} : -0,12 K (tr0: 0,12) PN16/PN25, PS25 IP68
Max permissible pressure	S/N: 82600325
Nominal resistance	Pt500 DS 27.5 mm A/T: 50
Type or nominal diameter	θ: 2...150 °C Δθ: 3...140 K
Permissible temperature range	TemperatureSensor 63
	CE M23 0200
	DK-0200-MI004-046
	Inlet t1
	kamstrup
	Temperature offset coefficient
	Marking of inlet or outlet
	Serial number
	Manufacturer logo
	Permissible differential temperature range
	Approval

Temperature sensors

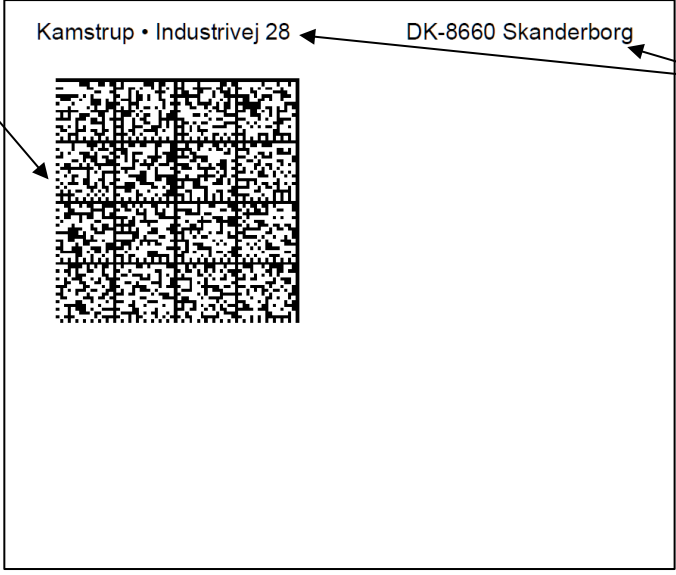
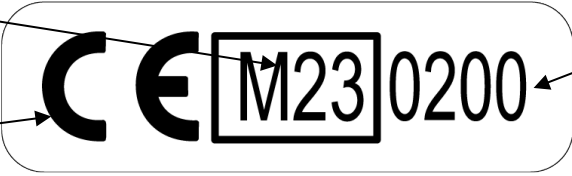
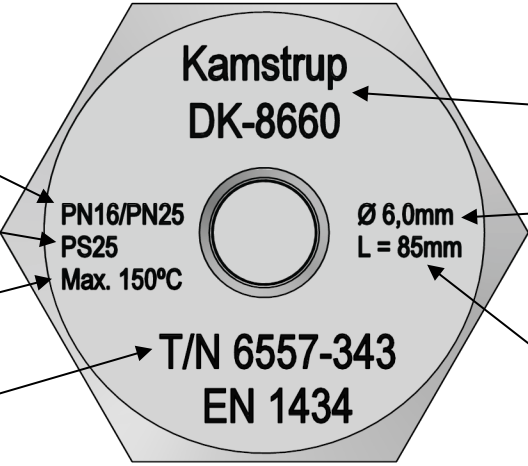
<p>Data matrix with data of the product, e.g. type number, serial number and temperature offset coefficient</p>	<p>Example of labelling of temperature sensor - back</p> 	<p>Postal address</p>
<p>Verification year</p> <p>Verification type</p>	<p>Example of MID-Module D verification mark</p> 	<p>Registration number of the notified body that has approved the verification site</p>
<p>Permissible pressure stage</p> <p>Max permissible pressure</p> <p>Max application temperature</p> <p>Type number</p>	<p>Example of labelling of sensor pocket</p> 	<p>Postal address</p> <p>Nominal inner diameter</p> <p>Pocket length</p>

6 Installation of temperature sensors

This chapter discusses the main conditions of installing temperature sensors, primarily focusing on the installation conditions that ensure correct temperature measurement.

6.1 Symmetric installation

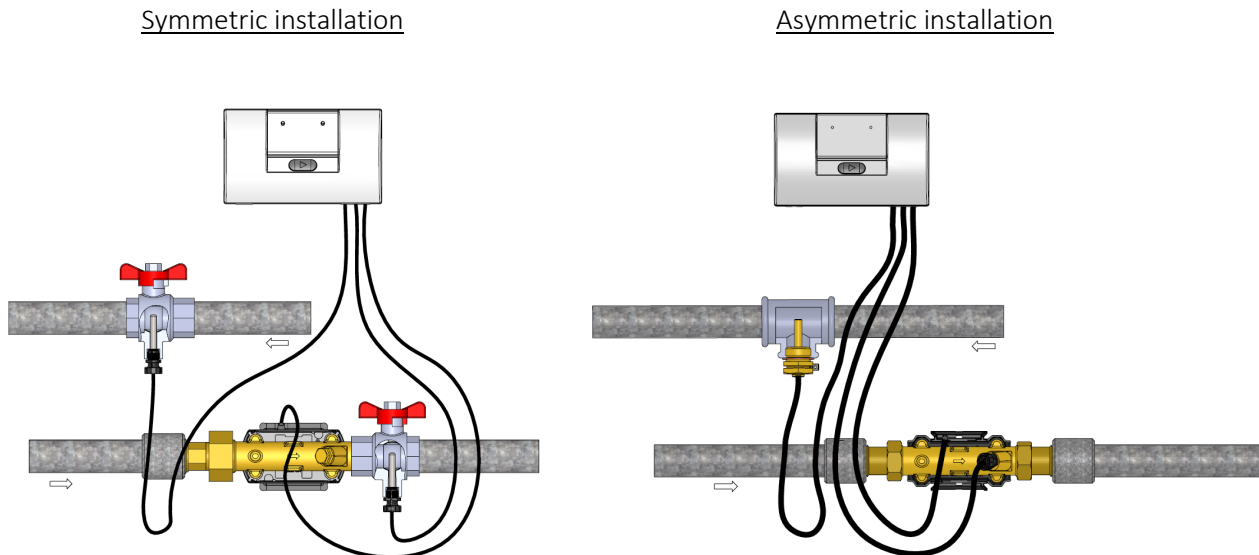

Figure 20: Examples of an symmetric installation and an asymmetric installation, respectively.

When installing temperature sensors, it is very important that the temperature sensors are installed in the same way in both the inlet and outlet. This is referred to as the symmetric installation. An example of this is shown in *Figure 20* where $\varnothing 5,2$ mm temperature sensors with composite unions are installed in two ball valves. An example of an asymmetric installation, however, is that one temperature sensor is installed as a direct temperature sensor, for example in the flow sensor, while the other temperature sensor is installed in a pocket. In a symmetric installation, it is ensured that there is no difference between the measurement characteristics of the two temperature sensors and that a correct temperature difference is thus calculated. In case of the asymmetric installation, such an installation will introduce two different errors, each affecting the measurement properties. First, if installed in a pocket rather than as a direct temperature sensor, the response time of a given temperature sensor will be significantly increased, and in case of the asymmetric installation, there will be a significant difference in response time of the two temperature sensors, which will lead to errors in determining the temperature difference. Second, a temperature sensor installed in a pocket will have a significantly increased heat conduction error compared with a direct temperature sensor. This will affect the temperature measured by the temperature sensor. If both temperature sensors are installed in a pocket, the error on both temperature sensors will be comparable and within the limits set for the correct measurement of the temperature difference. However, if one temperature sensor is installed in a pocket and the other temperature sensor as a direct temperature sensor, there will be a significant heat conduction error on one temperature sensor and a limited heat conduction error on the direct temperature sensor, and this will typically lead to the deviation of the measured temperature difference being greater than the specified limits, see paragraph 5.3.

Temperature sensors

A widely used installation method is to install one temperature sensor in the flow sensor and the other temperature sensor in either a ball valve or nipple. As both temperature sensors are installed as direct temperature sensors, this installation method is also considered to be a metrologically correct installation, see *Figure 21*.

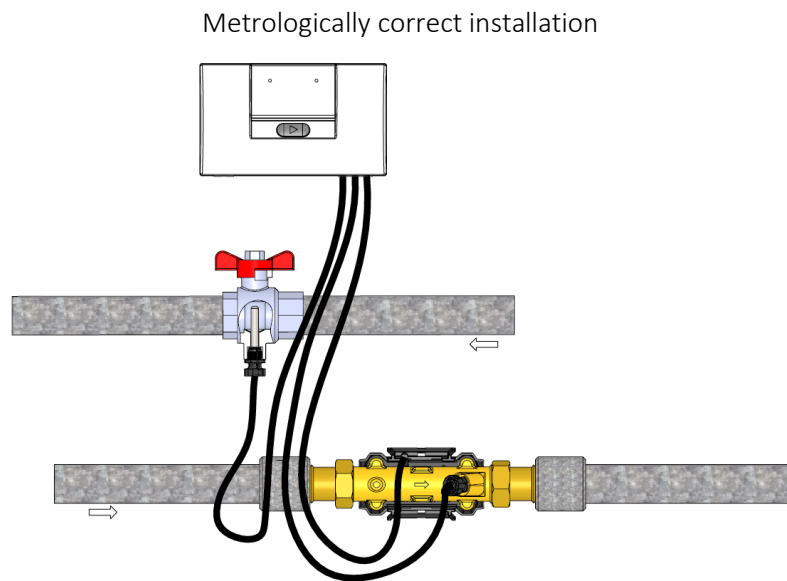

Figure 21: An example of a metrologically correct installation.

6.2 Installation length

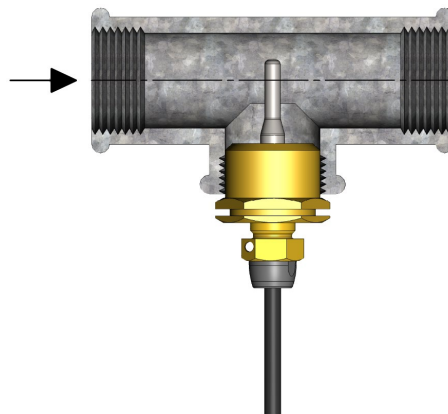

Figure 22: Example of correct installation of a direct short temperature sensor.

Based on the paragraph about the qualifying immersion depth, it is important to consider that the temperature sensor is correctly positioned in the pipe for the best possible measurement. When installing a DS 27,5 mm temperature sensor in small pipes such as DN15 and DN20, be aware that the temperature sensor must be placed as far into the pipe as possible to comply with the qualifying immersion depth requirement as stated in the approval. An example of this is shown in *Figure 22*.

When installing in, for example, a 90° angle, be aware that the temperature sensor must be placed relatively far into the pipe before you can be sure that the temperature sensor is measuring the correct temperature. An example of correct installation in a 90° angle is shown in *Figure 23*.

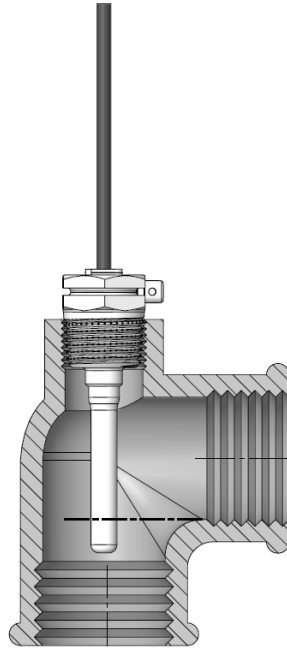

Figure 23: Example of correct installation of pocket sensor in a 90° angle.

6.3 Installation in large pipes

Normally, only one temperature sensor is used in each pipe and this is done assuming that the temperature in the pipe is relatively homogeneous. In large pipes, e.g. above DN100, stratification may occur inside the pipe. The stratification is caused by hot water searching upwards. Stratification becomes more critical at high temperatures due to a larger temperature difference between the medium and the surroundings as well as at low flow rates. In case of stratification, the temperature in the pipe is no longer homogeneous and therefore, a single temperature sensor is not necessarily representative of the average temperature in the pipe. In such cases, the temperature measurement can be improved, as shown in *Figure 24*, by using four temperature sensors connected in a combination of series and parallel connections. The combination of series and parallel connections means that the four temperature sensors together have the same nominal resistance as if only one temperature sensor had been used. If the four temperature sensors are positioned as shown in *Figure 24*, they will measure four different temperatures due to the stratification that, due to the combination of series and parallel connections, will result in a more representative average temperature.

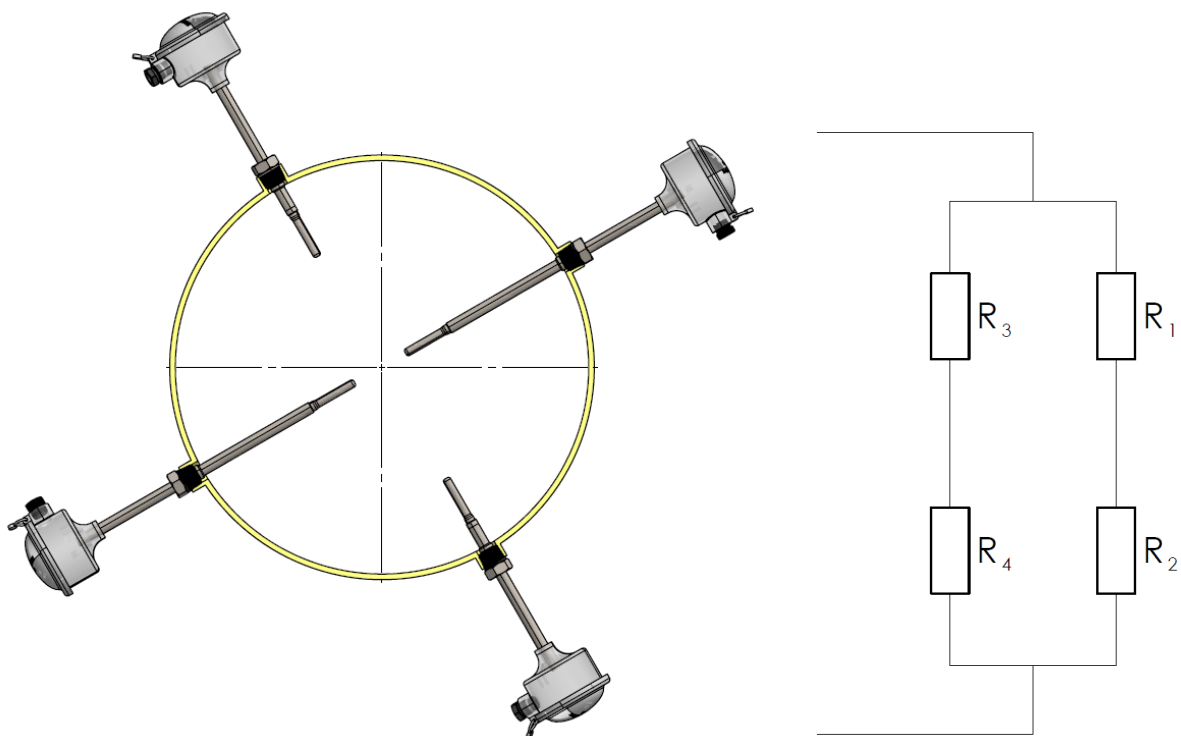

Figure 24: An example of an installation where a more representative average temperature is obtained by using four different temperature sensors connected by a combination of series and parallel connection.

6.3.1 Connection example: 4 temperature sensors with 2-wire

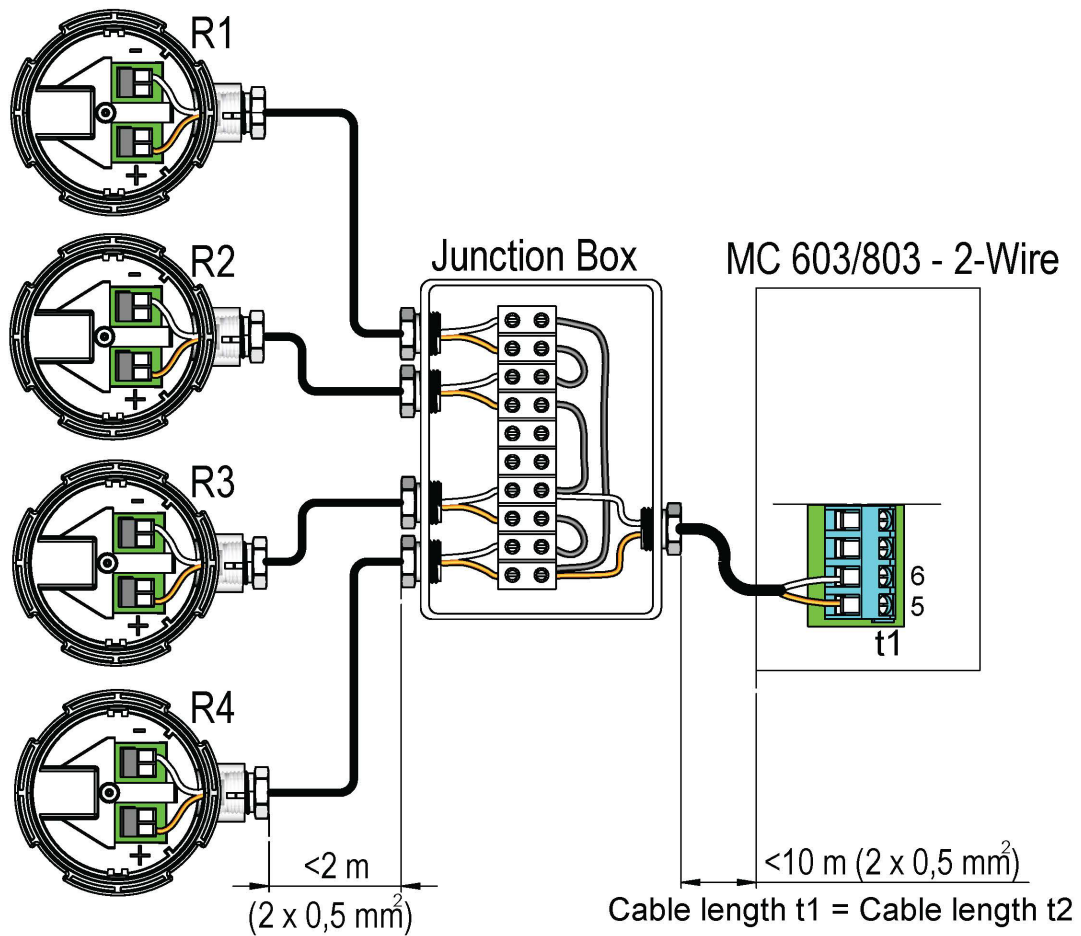

Figure 25: Example of an installation of 4 temperature sensors in one pipe. The installation is carried out with 2-wire connection, which gives a limitation of the cable length of 10 m. In this example, the connection of t1 (inlet sensor) connected to the MULTICAL® 603 calculator is shown. The corresponding installation must be carried out for t2 (outlet sensor).

Temperature sensors

6.3.2 Connection example: 4 temperature sensors with 2-wire combined with 4-wire

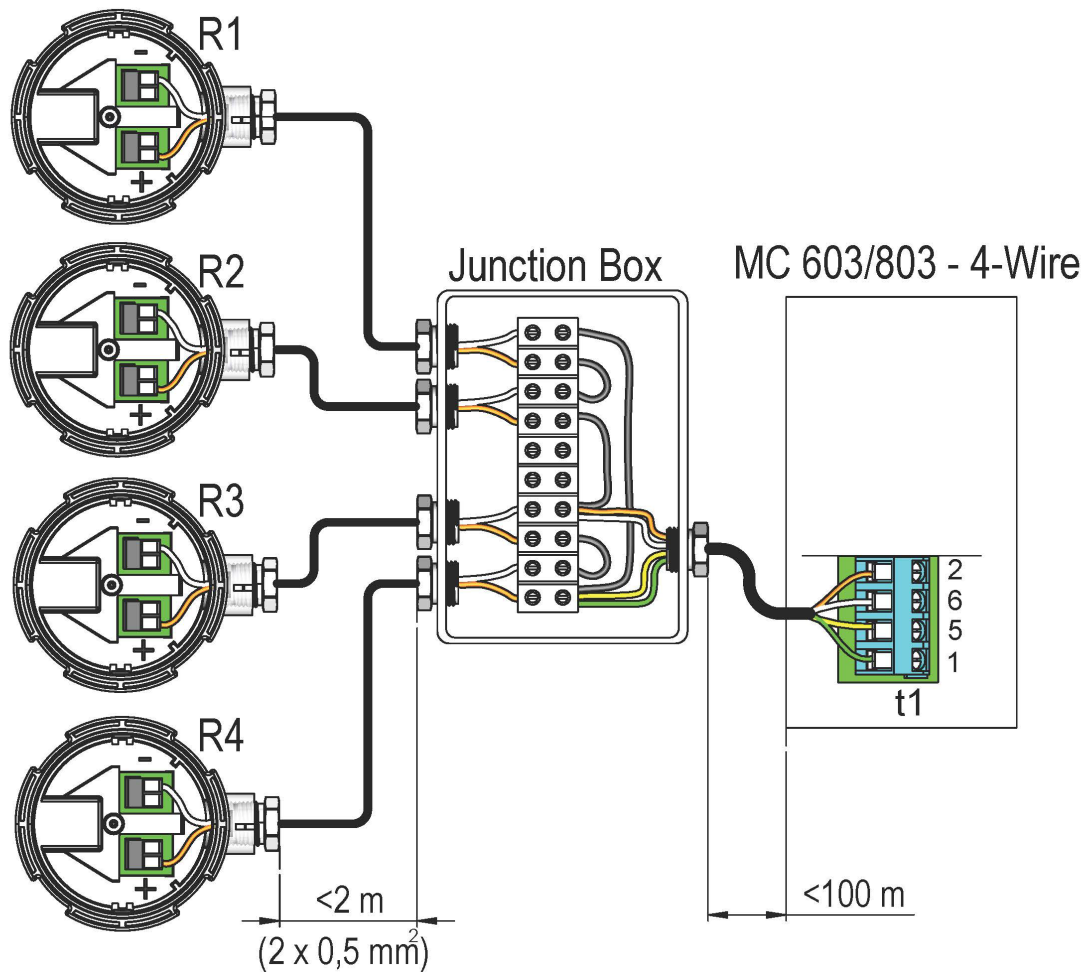

Figure 26: Example of an installation of 4 temperature sensors in one pipe. The installation is carried out with 2-wire connection in combination with 4-wire connection, which enables a cable length of up to 100 m between calculator and temperature sensors. In this example, the connection of t1 (inlet sensor) connected to the MULTICAL® 603 calculator is shown. The corresponding installation must be carried out for t2 (outlet sensor). Other approved calculators such as MULTICAL® 803 can be used in the same way.

6.3.3 Connection example: 4 temperature sensors with 4-wire

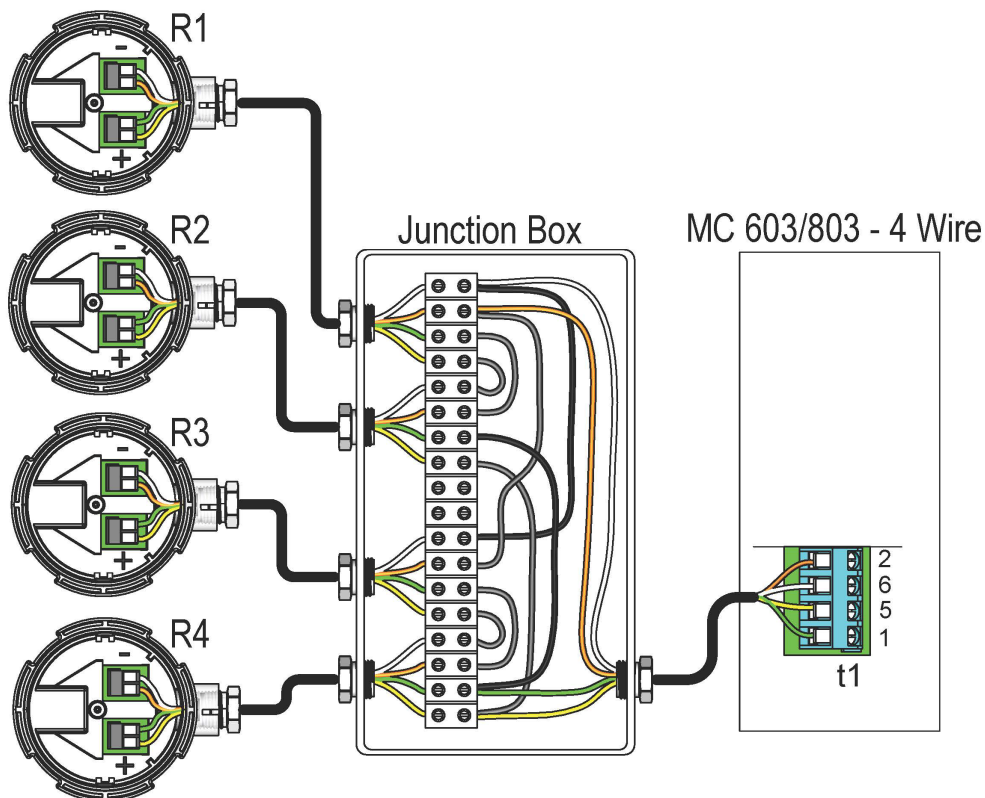

Figure 27: Example of an installation of 4 temperature sensors in one pipe. The installation is carried out with 4-wire connection, which enables a cable length of up to 100 m between calculator and temperature sensors. In this example, the connection of t1 (inlet sensor) connected to the MULTICAL® 603 calculator is shown. The corresponding installation must be carried out for t2 (outlet sensor). Other approved calculators such as MULTICAL® 803 can be used in the same way.

6.4 Other installation conditions affecting the temperature measurement

A more correct temperature measurement is achieved by limiting the heat conduction into the surroundings as the heat conduction will cause a temperature measurement error. The heat conduction into the surroundings can be limited by insulating the temperature sensors. If you choose to insulate the temperature sensors, you should be aware that both temperature sensors are similarly insulated as the insulation of a single temperature sensor may conversely help to introduce an additional error in the measurement of the temperature difference. Further information about insulation of two temperature sensors can be found in Kamstrup's insulation manual for flow sensors and temperature sensors, 5512-2376. For pocket sensors, the response time can be reduced by using heat-conducting paste in the pocket. As heat-conducting paste results in a significant reduction in response time, it is also important that the same amount of heat-conducting paste is used in both pockets. Over time, most heat-conducting pastes tend to dry out. Therefore, the use of heat-conducting paste may mean that the temperature sensor cannot be removed from the pocket at a later time due to the solidified heat-conducting paste. At the same time, it should be borne in mind that the use of heat-conducting paste may be regulated by national legislation due to its high impact on the temperature measurement. It has, for example, been experienced that heat-conducting paste is not allowed in some countries.

6.5 Installations with high flow rates and/or a high combination of pressure and temperature

For temperature sensor pockets, welded pockets may only be used at flow rates up to 3 m/s. At higher flow rates, there are examples of welded pockets breaking, probably due to the pocket being exposed to its characteristic resonance frequency. For flow rates higher than 3 m/s, a reinforced pocket turned out of one piece is recommended, see paragraph 3.2.2. In *Table 8*, the flow corresponding to a flow rate of 3 m/s is shown for selected pipe diameters. If a higher flow is used than the number in the table, it is recommended to use a reinforced pocket turned out of one piece. Similarly, it is also recommended to use reinforced pockets turned out of one piece for installations with a high combination of pressure and temperature, e.g. PN40 installations, and where a broken pocket will cause a high risk of injury.

Nominal pipe diameter [DN]	Flow [m ³ /h]	Flow [L/h]
50	21	21195
65	36	35820
80	54	54259
100	85	84780
125	132	132469
150	191	190755
200	339	339120
250	530	529875
300	763	763020

Table 8: Flow for selected pipe diameters corresponding to a flow rate of 3 m/s.

6.6 Sealing of two temperature sensors

As described in paragraph 6.2, a correct temperature measurement depends on a satisfactory installation length of the temperature sensor. To ensure that no subsequent changes are made to the installation after proper installation, the installation is often sealed. This is usually done using a wire that is finally sealed, called a sealing wire. For direct short temperature sensors, so-called sealing shells that surround the brass union can also be used. The sealing shells are available in both a red version, which is used to seal a temperature sensor mounted in the inlet, and a blue version, which is used to seal a temperature sensor mounted in the outlet. A number of examples of sealing both with sealing wire and sealing shells are shown in *Figure 28*.

Examples of sealing of direct short temperature sensor mounted in a nipple

Article number at red sealing shells, 3026-518

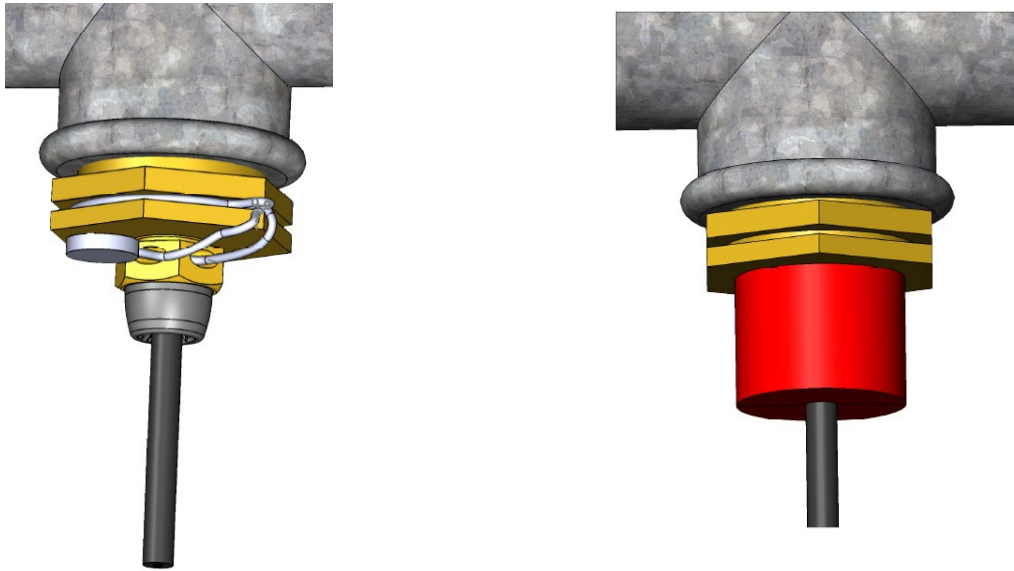

Examples of sealing of direct short temperature sensor mounted in a flow sensor

Article number at blue sealing shells, 3026-517

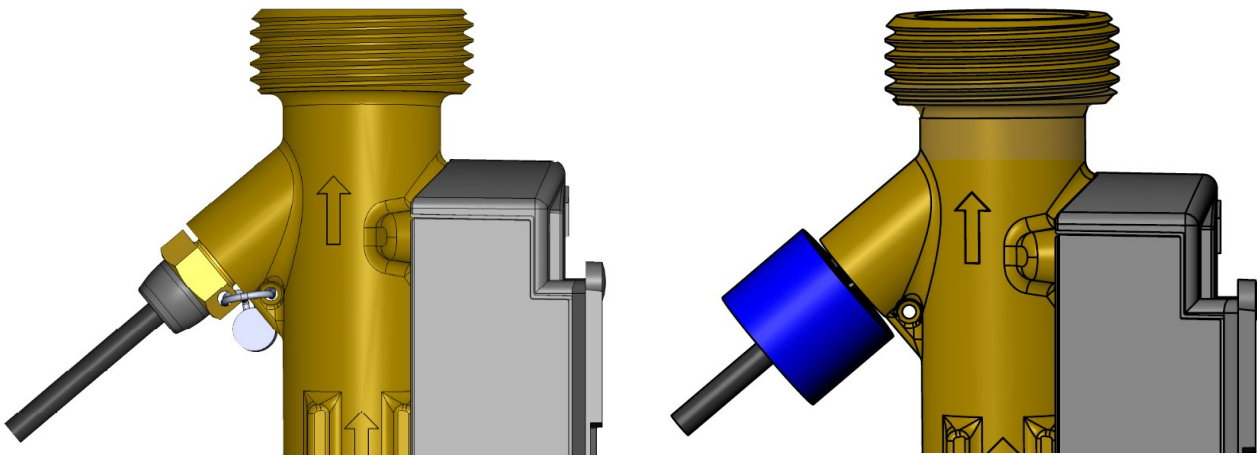

Temperature sensors

Examples of sealing of pocket sensor

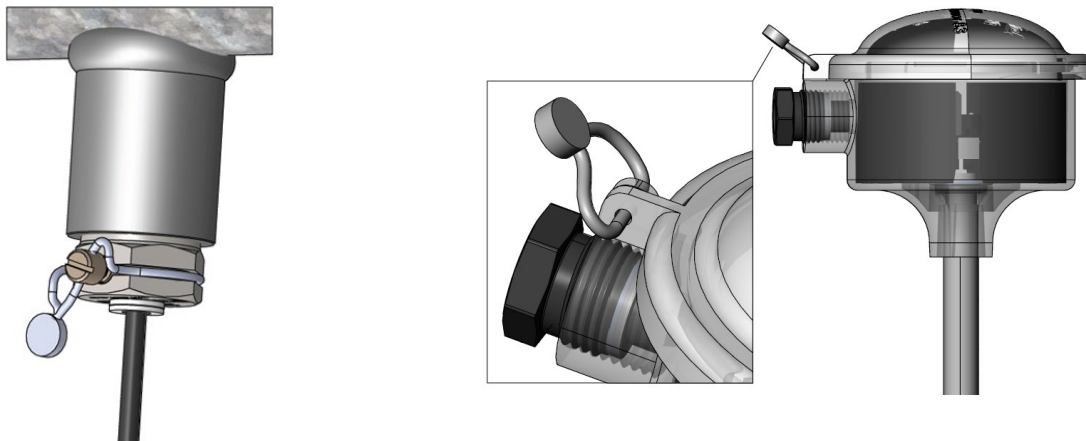

Examples of sealing of direct short temperature sensor mounted in countersunk nipple

Article number at grey sealing shells, 3026-1330 (R $\frac{1}{2}$ "") and 3026-1331 (R $\frac{3}{4}$ "")

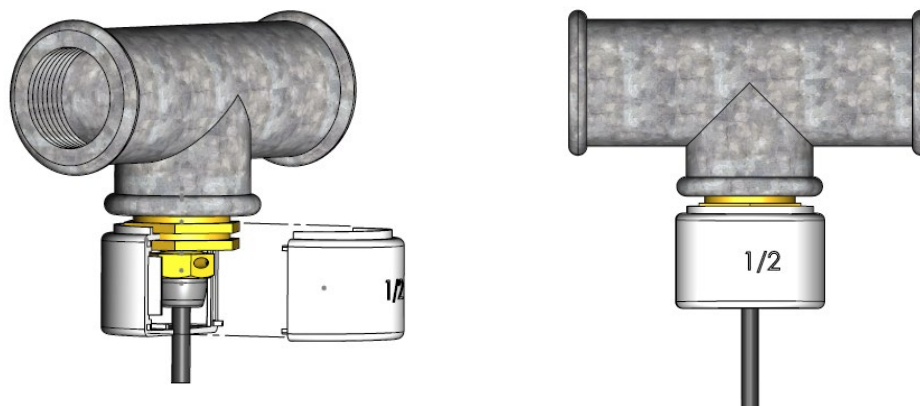

Figure 28: Examples of sealing of temperature sensors, either with sealing wire or sealing shells.

7 Accessories for the installation of temperature sensors

This chapter describes some of the most commonly used types of accessories for installing direct short temperature sensors, including ball valves, nipples, tee and 11 mm adapter for DS 38 mm temperature sensor.

7.1 Ball valve

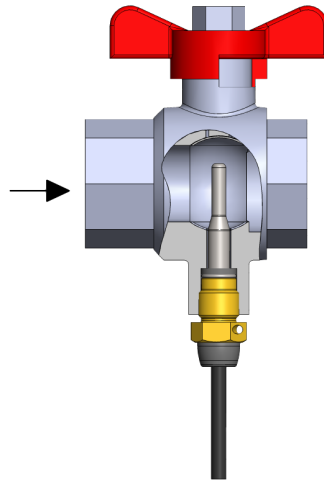

Figure 29: Direct short DS 27,5 mm temperature sensor mounted in a ball valve.

By installing a ball valve with M10x1 insert for a temperature sensor, it is possible to install a direct short temperature sensor without draining the installation of water. The ball valve operates by turning the handle, temporarily blocking the water flow during installation by a ball-shaped valve. The installation of temperature sensors in a ball valve also has the advantage of allowing the temperature sensor to, as far as possible, be placed optimally within the fluid flow.

7.2 Installation in old ball valves

When installing TemperatureSensor 63 \varnothing 5,0 and \varnothing 5,2 in ball valves that do not follow EN 1434:2022, distance washers must be used. In old ball valves, the O-ring cannot be stretched just as well as in ball valves that follow the new standard, and this may lead to leakages in the installation. Therefore, a distance washer must be used with the temperature sensor to ensure that the O-ring is pushed down correctly and seals the installation.

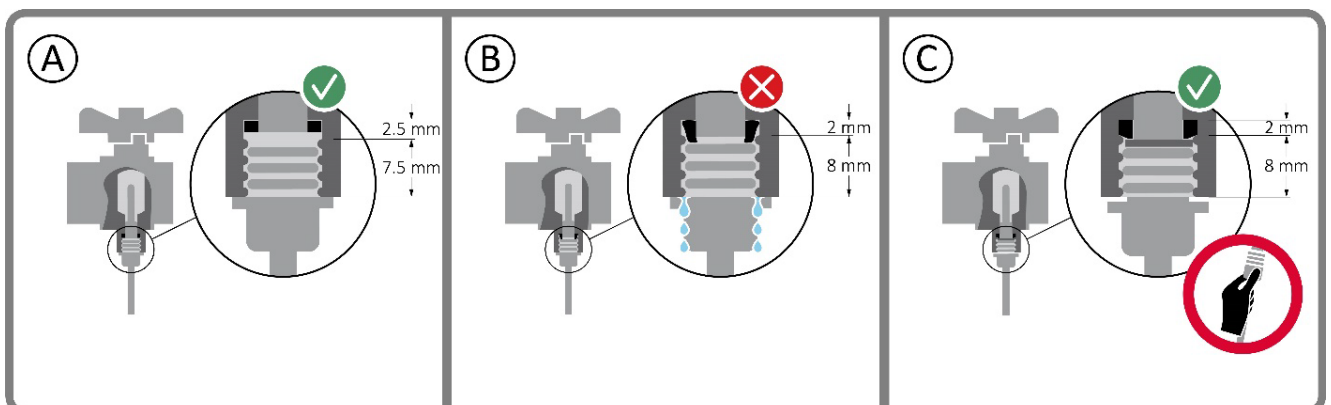

Figure 30: TemperaturSensor 63 \varnothing 5,0 or \varnothing 5,2 installed in ball valves (A) according to EN 1434:2022 or (B), (C) according to earlier versions of EN 1434

Temperature sensors

7.3 Nipple

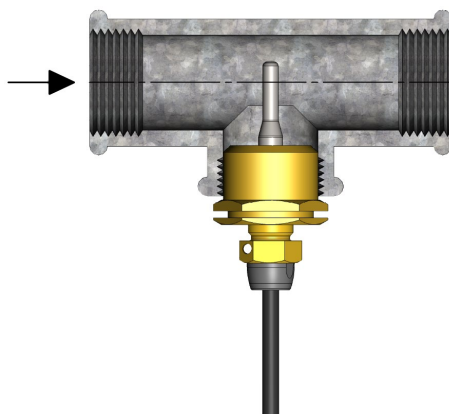

Figure 31: Direct short DS 27.5 mm temperature sensor mounted with nipple in a tee.

A highly used solution for installing direct short temperature sensors is to use a brass nipple with, for example, $R\frac{1}{2}$ or $R\frac{3}{4}$ thread, which is installed in a corresponding tee. For nipples with cone-shaped threads, use packing cord or Teflon tape to obtain the required seal, while straight-threaded nipples typically use a copper gasket.

7.4 Tee with M10x1 thread

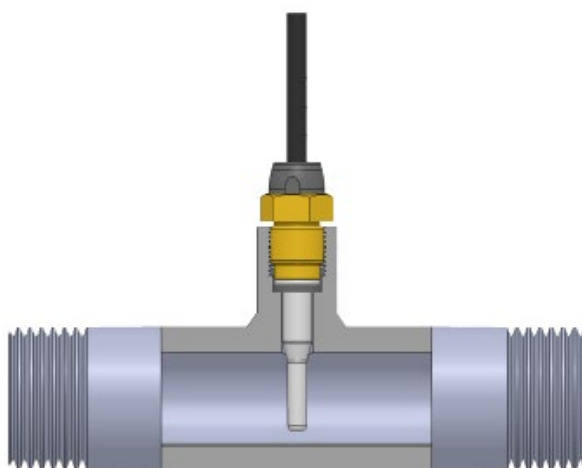

Figure 32: Direct short DS 27,5 mm temperature sensor mounted in tee with M10x1 thread.

Installing a direct short temperature sensor in a tee with M10x1 thread is typically used if you want to reposition the flow sensor so that it is then, for example, placed in the inlet instead of in the outlet. In this case, a tee with M10x1 thread is a good and practical choice for establishing a new location for installing the temperature sensor that is not installed in the flow sensor.

7.5 11 mm adapter for DS 38 mm temperature sensor

As can be seen from *Table 3*, a DS 27,5 mm temperature sensor can be used in DN15 to DN25 installations and a DS 38 mm temperature sensor can be used in DN32 and DN40 installations. By mounting an 11 mm adapter on a DS 38 mm temperature sensor, a DS 38 mm temperature sensor can also be used in small installations from DN15 to DN25, see *Table 9*. This may be particularly relevant in old installations where subsequent reconstruction/re-insulation have resulted in the inlet pipe being DN40 and the outlet pipe being DN25.

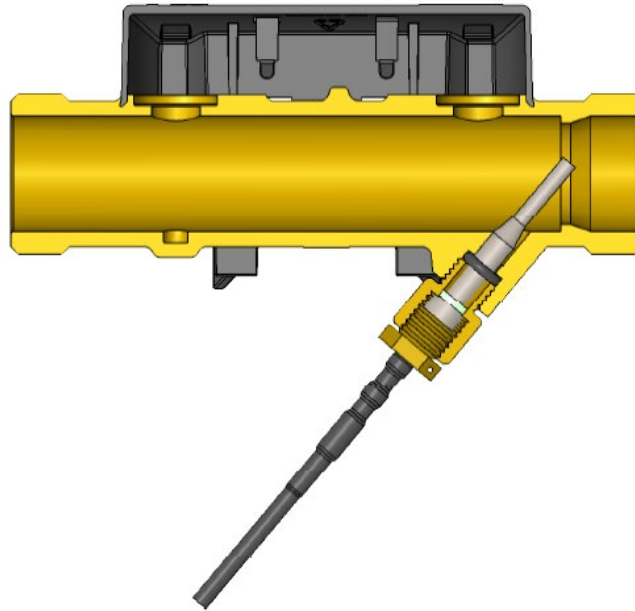

Figure 33: Direct short DS 38 mm temperature sensor mounted with 11 mm adapter in a flow sensor.

DN	DS 27,5 mm	DS 38 mm	DS 38 mm with 11 mm adapter
15	X		X
20	X		X
25	X		X
32		X	
40		X	

Table 9: Overview of the use of direct short temperature sensors, both with and without 11 mm adapter

8 Application of temperature sensors for cooling meters

Basically, the same temperature sensors are used for both heat and cooling meters. In this chapter, some of the special conditions that should be observed when using temperature sensors for cooling meters are described.

8.1 Correct measurement of the inlet temperature

In the field of remote cooling, the customer is often guaranteed a given inlet temperature of, for example, 6 °C. As the temperature difference between the inlet and the outlet is used to calculate the energy consumption, the two temperature sensors in a pair of temperature sensors are basically produced to obtain a correct measurement of the temperature difference, see paragraph 5.3.

However, the absolute temperature, i.e. the temperature measured by the individual temperature sensor, used to determine whether the requirement of the 6 °C for the supply temperature is complied with, is specified in the EN 1434 standard to deviate up to 2 K. If this deviation on the temperature sensor results in the actual temperature of the supplied district cooling water being in practice above 6 °C, even if the cooling meter displays 6 °C, the customer is not receiving the promised product. Conversely, if the actual temperature of the supplied district cooling water is below 6 °C, even if the meter displays 6 °C, unnecessary resources are used to supply district cooling water that is colder than the required 6 °C. Therefore, if the customer is guaranteed a given supply temperature of, for example, 6 °C, it should be ensured that the deviation of the measured inlet temperature is as small as possible.

The deviation of the absolute temperature is caused by several factors. First, the platinum resistance used in the temperature sensor will have a deviation from a perfect platinum resistance as defined in EN 60751. Typically, a class B platinum resistance is used, which is specified to have the following deviation:

$$\pm (0,3 + 0,005 \times T) \text{ K}$$

where T is the temperature.

	Class B
Requirement for maximum deviation	$\pm (0,3 + 0,005 \times T) \text{ K}$
Deviation at $T=0 \text{ °C}$	$\pm 0,3 \text{ K}$
Deviation at $T=20 \text{ °C}$	$\pm 0,4 \text{ K}$

Table 10: Calculation of permissible deviation for a class B temperature sensor according to EN 60 751.

As can be seen from *Table 10*, the maximum deviation of the platinum element will be up to $\pm 0.4 \text{ K}$ when used in district cooling applications. In addition to the platinum element, the calculator itself also has uncertainty about the temperature measurement and it is typically $\pm 0,2 \text{ K}$.

The last factor that can affect the absolute temperature measurement is the cable of the temperature sensor. This is because the cable has a resistance that increases the total resistance of the entire temperature sensor. For a Pt500 temperature sensor, the measured absolute temperature is increased by max 0.08 K per running metre of cable using a 0,25 mm² cable. This means that the measured temperature of a Pt500 temperature sensor with 5 m cable will be increased by 0.4 K. For 4-wire temperature sensors, the cable does not increase the measured resistance, see paragraph 2.2.2. This difference helps to make more use of 4-wire sensors in the case of cooling meters. For Pt100 temperature sensors, however, the cable increases the measured absolute temperature by 0,4 K per running metre of cable using a 0,25 mm² cable. Therefore, it is not recommended to use Pt100 temperature sensors for cooling measurements.

If the above factors are combined, the result is that the absolute deviation will typically be between +1,0 K and -0,2 K for 2-wire Pt500 temperature sensors with 5 m cable, while it for 4-wire Pt500 temperature sensors typically will be between -0,6 K and +0,6 K.

The MULTICAL® 403, MULTICAL® 603 and MULTICAL® 803 calculators are available with an offset adjustment function that allows for an absolute temperature adjustment of up to $\pm 0,99$ K in the calculator. As the above deviations in the absolute temperature are determined during the temperature sensor calibration, the use of the offset adjustment function will result in a reduction of the absolute deviation to typically less than $\pm 0,1$ K. As both the inlet and outlet temperatures are adjusted by the same value, the offset adjustment does not affect the calculation of the amount of energy consumed.

8.2 Condensation problems

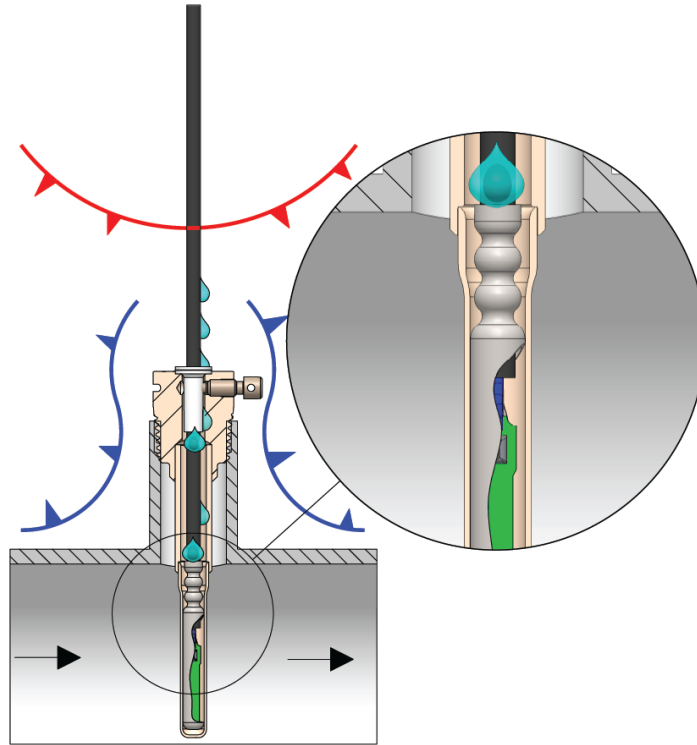

Figure 34: Penetration of condensation into a pocket sensor.

When hot air with relatively high humidity comes into contact with a cold surface, the air is cooled down and the moisture in the hot air forms condensation on the cold surface. In connection with district cooling where water is typically circulated in the district cooling pipes, which are for example 5 to 15 °C and thus significantly colder than the surroundings, it is therefore well-known within the field of cooling meters that problems may occur due to condensation. This also applies to temperature sensors where the penetration of water into the temperature sensor may cause the temperature sensor to fail. This issue is illustrated in *Figure 34*.

Temperature sensors

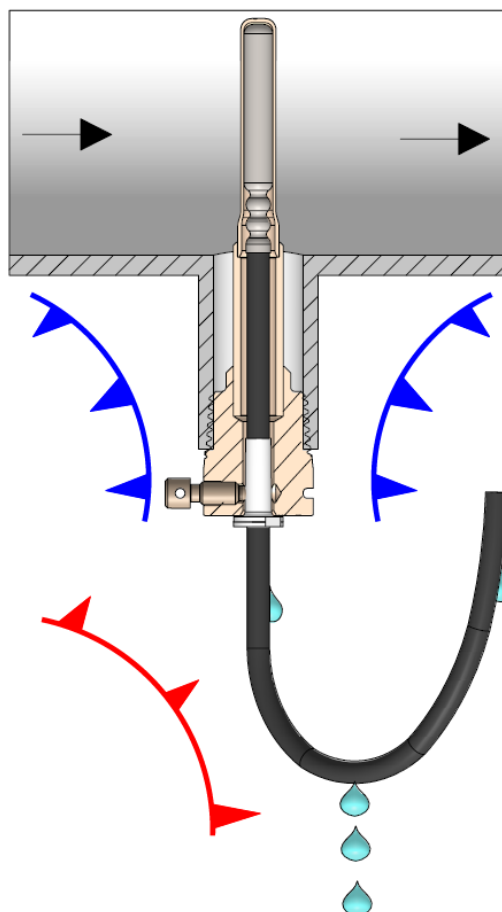

Figure 35: Correct installation of a temperature sensor for use in cooling measurements by which gravity prevents the penetration of condensation.

Condensation issues can be minimized by mounting the temperature sensors from below, causing gravity to drain the water formed, for example, inside a pocket. This solution to the problems of condensation is illustrated in *Figure 35*.

9 References

- [1] <https://webshop.ds.dk/Default.aspx?ID=120&q=Varmem%C3%A5lere>
- [2] <https://standards.globalspec.com/std/1199183/en-60751>
- [3] <https://www.jumo.de/products/temperature/temperature-sensors/thin-layer/906122/platinum-chip-temperature-sensors-of-smd-design-type-on-epoxy-pcb-according-to-din-en-60751-pcse---pcsm-design-type-906122.html?parentId=2917>
- [4] https://www.heraeus.com/en/hne/sensor_products/sensors.aspx
- [5] <https://www.jumo.de/products/temperature/temperature-sensors/thin-layer/906121/platinum-chip-temperature-sensors-with-connection-wires-according-to-din-en-60751-pca-design-type-906121.html?parentId=2917>