

Installation manual

• —————
OMNIPOWER – single-phase



Installation manual

Connect the meter in accordance with the installation diagram on the meter's type label. Depending on the configuration, a fixed value is displayed, or the display changes between selected indications every 10 seconds.

It is possible to change the display reading manually by activating the push button on the meter. The available readings depend on the meter's configuration.

Security and installation guidelines

The meter is only to be used for measuring electrical energy and shall operate within the specified values only.

The meter must be disconnected when working on it. It can be highly dangerous to touch the meter parts when the meter is switched on.

Therefore, the relevant security fuse must be removed and kept in a place where it cannot be inserted by unauthorized persons.

Current local standards, guidelines, regulations and instructions must be observed. Only authorized personnel is permitted to install electricity meters.

Meters for direct connection must be protected against short circuit by a security fuse in accordance with the maximum current stated on the meter.

Failing to obey the "Guidelines for safety and installation", the guarantee no longer applies.

Installation manual

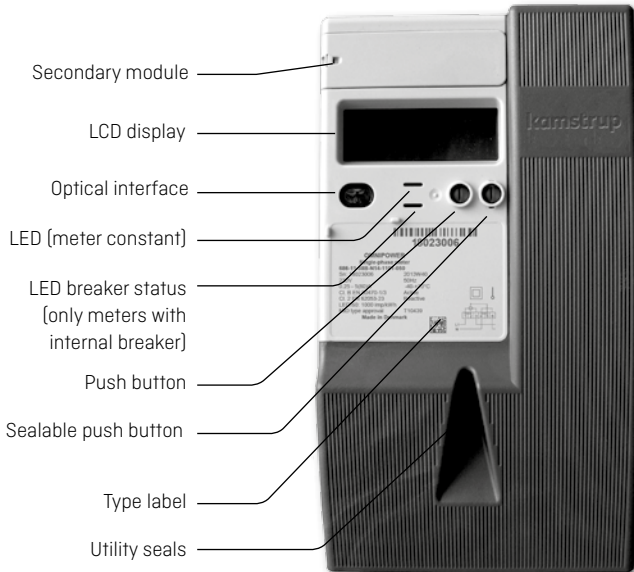

The meter constant LED blinks proportionally to the consumed active energy.
Only authorized personnel may break the utility sealing.

Installation manual

The phase indications have various functions. They indicate the two situations described below.

From the connection of the meter:

Indications	L1	Indicate
On		Voltage is above minimum limit (160V)
Off		Voltage is below minimum limit (160V)
Indications	\rightleftarrows^+	Indicate
On		Load is above minimum limit (2.3W)
Off		Load is below minimum limit (2.3W)

If the load exceeds the minimum limit and the meter is configured with this reading, consumption will be indicated via the quadrant reading. The direction of the phase current is also indicated by the arrow of L1, regardless of configuration.

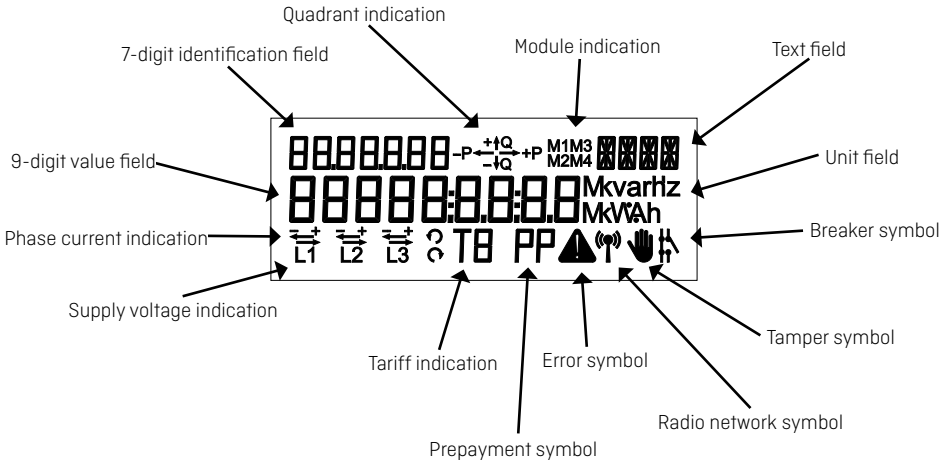

Installation manual

Terminals OMNIPOWER

	Multi-core	7-core	Massive / terminals
35 mm ²	≥ 6 mm ²	≥ 6 mm ²	≥ 2.5 mm ²
Screw:	Pz 2 or straight slot		
Torch:	2.5 – 3 Nm		

OMNIPOWER ST-meter

Multi-core	7-core
> 6 mm ²	> 6 mm ²
Screw:	Pz 2 or straight slot
Torch:	3 – 3.5 Nm

Load control, installation

For meters with load control relay(s). Due to the delay in the meter, it is important to re-start the meter (off/on) when the time is set correctly in the meter. This places the relays in the correct position and stops the delay timer.

With built-in radio

If the meter is supplied with integral radio for establishment of remote reading, the meter automatically starts to connect to a radio network. The integral radio is equipped with an internal antenna. The radio signal strength can be read via the system. If the radio signal is not sufficient, an external antenna must be connected. Please see current documentation on available antennas.

Mounting a communication module in the meter may influence the radio communication. Please contact Kamstrup A/S.

With disconnect function

With this type of meter, it must be checked that the red diode is switched off. This indicates that the consumer's supply is disconnected.

Installation manual

Installation dimensions

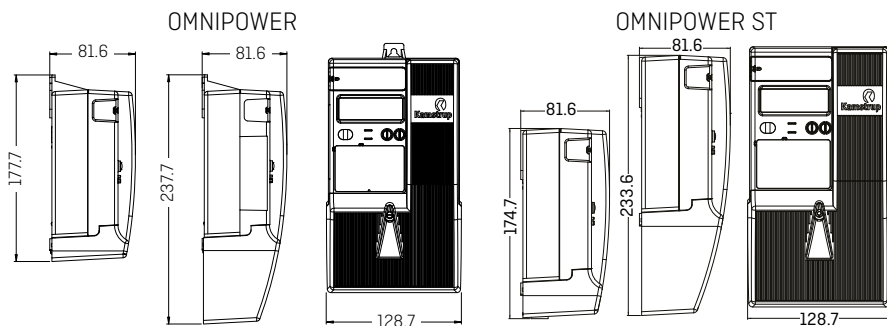

Connection diagrams

The valid connection diagram appears from the type label.

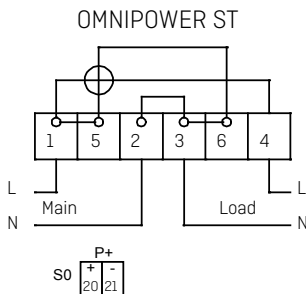
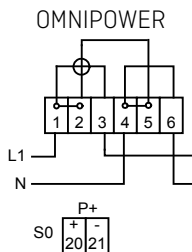

Connection diagram for modules

