

Technical description

Calibration unit for  
MULTICAL<sup>®</sup> 603



Glossary, formulas and abbreviations

Letter/Symbol	Meaning / Formula	Unit
t1	Inlet temperature (also called Tf)	°C
t2	Outlet temperature (also called Tr)	°C
$\Delta\Theta$	Temperature difference t1-t2	K
$\Delta\Theta_{min}$	Minimum temperature difference = 3K according to MID	K
TrueV	Simulated volume during auto integration	litres
k	Heat coefficient from EN1434-1	kWh/m <sup>3</sup> /K MJ/m <sup>3</sup> /K
True E	Calculated true energy	kWh
Measured E	Measured energy	kWh, MWh, GJ
Deviation	$(\text{Measured Energy} - \text{True Energy}) \times 100 / \text{True Energy}$	%
U	Uncertainty	%
MPE	Maximum Permissible Error	%
EN 1434	European standard for thermal energy meters	
Auto integration	Energy calculation based on volume simulation via serial data communication	

## Contents

1	General description .....	4
1.1	Introduction .....	4
1.2	Equipment.....	4
1.3	Functional diagram .....	5
2	Calibration.....	6
2.1	Calibrating MULTICAL® 603.....	6
2.2	Verification unit settings .....	7
2.2.1	Permissible error and Uncertainty.....	7
2.2.2	Heat coefficients in inlet and outlet pipe.....	7
2.2.3	Number of integrations .....	8
2.2.4	Test points .....	8
2.2.5	Measured resistance .....	8
2.3	Test report .....	9
2.4	Calibration of the equipment.....	11
2.4.1	Measuring t1 and t2 .....	11
2.4.2	Procedure .....	11
2.5	Calculations .....	13
2.5.1	Calculating t1 and t2.....	14
3	Uncertainty .....	15
3.1	Calculating equipment uncertainty .....	15
3.2	Examples of uncertainty calculated for Pt500 type.....	16
3.2.1	Points t1 and t2: 15 °C and 18,3 °C .....	16
3.2.2	Points t1 and t2: 160 °C and 20 °C .....	16

## 1 General description

Calibration units, 6699-363/364/365, are designed to perform a calculator calibration of Kamstrup's heat and/or cooling meters, of the type MULTICAL® 603 with Pt500 (requires calibration unit 6699-363 for 2 wire and 6699-364 for 4 wire) or Pt100 (requires calibration unit 6699-365) temperature sensors.

### 1.1 Introduction

Kamstrup's calibration units (6699-363/364/365) are, together with software product "METERTOOL HCW" (6699-724), used for the calibration. Various inlet- and outlet temperatures are simulated which, together with volume simulation, form the basis for verifying the energy calculation. The test does not include the temperature sensors or the flow part.

### 1.2 Equipment

The calibration unit is primarily designed for use by laboratories, calibrating heat and/or cooling meters and can as well be used to test the calculator functions, also on-site.

The calibration unit is housed into a standard MULTICAL® 603 base, containing calibration PCB with microprocessor, control relays, precision resistors, etc. The top of MULTICAL® 603 can simply be installed on top of the calibration unit, using this in place of the standard meter base.

During the test, the calibration unit is supplied via the USB connection. The microprocessor simulates the volume with the use of auto integration or by sending actual pulses to the meter. Temperature simulation is achieved by means of fixed precision resistors, which change automatically via relays that are controlled by the microprocessor.

After the test, the PC reads all the registers in the meter and compares the values with the true values calculated. The deviation determined for each test point, shown in percent, can be printed on a test certificate and/or stored in the PC (using METERTOOL HCW) under the serial number of the meter tested.

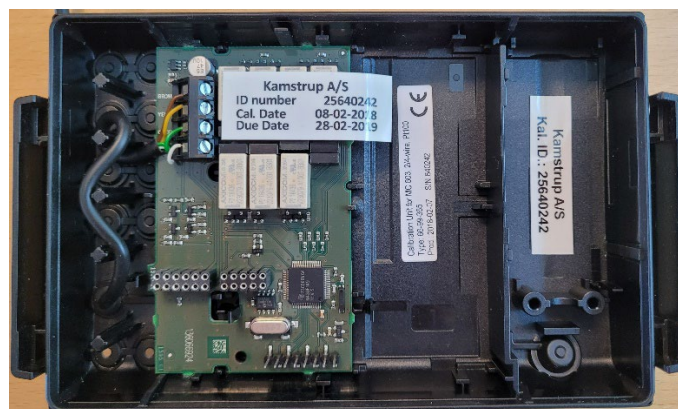

System requirements and installation guidelines for METERTOOL can be found in the technical description of METERTOOL HCW, 5512-2097.

### 1.3 Functional diagram

A functional diagram of the needed equipment to calibrate MULTICAL® 603 is seen below. It consists of the calibration unit, the calculator and a PC running METERTOOL HCW.

The microprocessor controls the temperature simulation of t1 and t2 by controlling the relays with different resistor values. Type no. 6699-363 includes a functional test of temperature T3.

Moreover, the microprocessor simulates the volume as well as uses autointegration.

Data is sent to and from METERTOOL HCW through the USB cable.

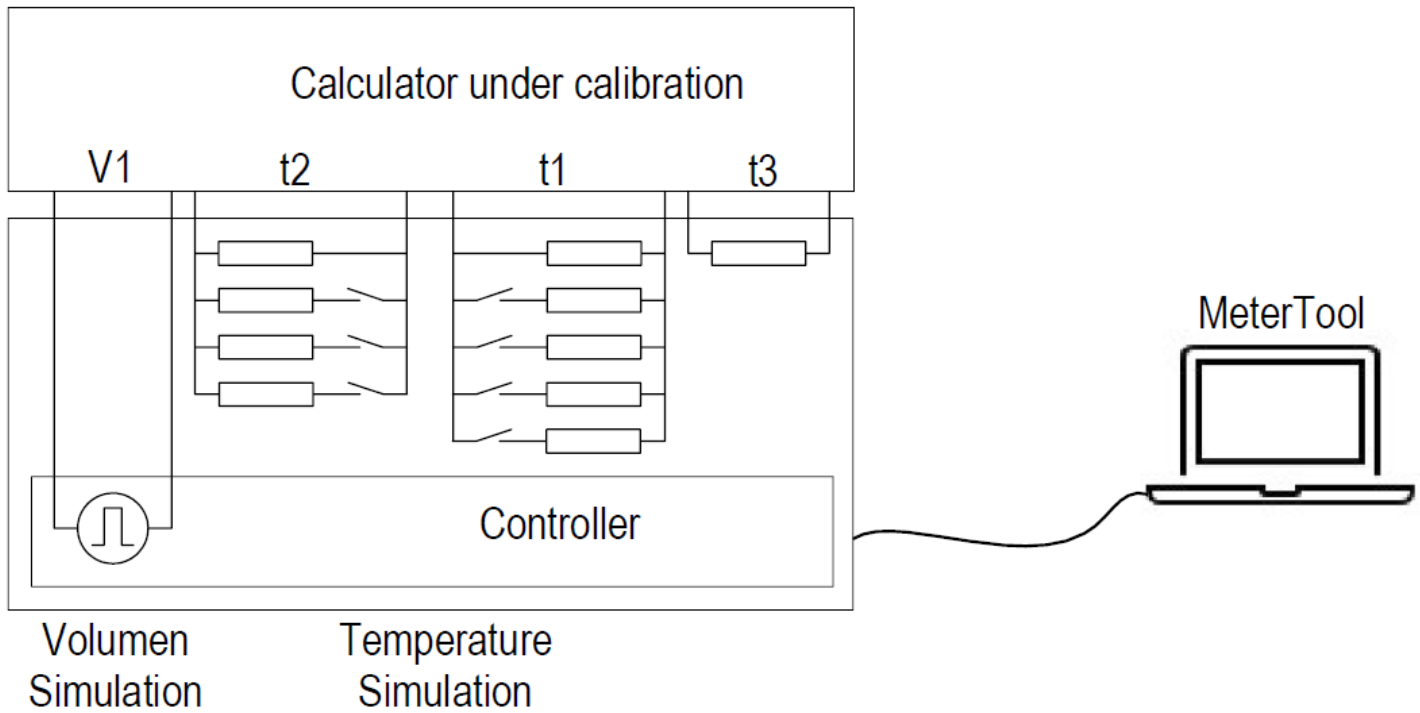

## 2 Calibration

To calibrate MULTICAL® 603, the “Verification” tab in METERTOOL HCW is used, which is shown below:

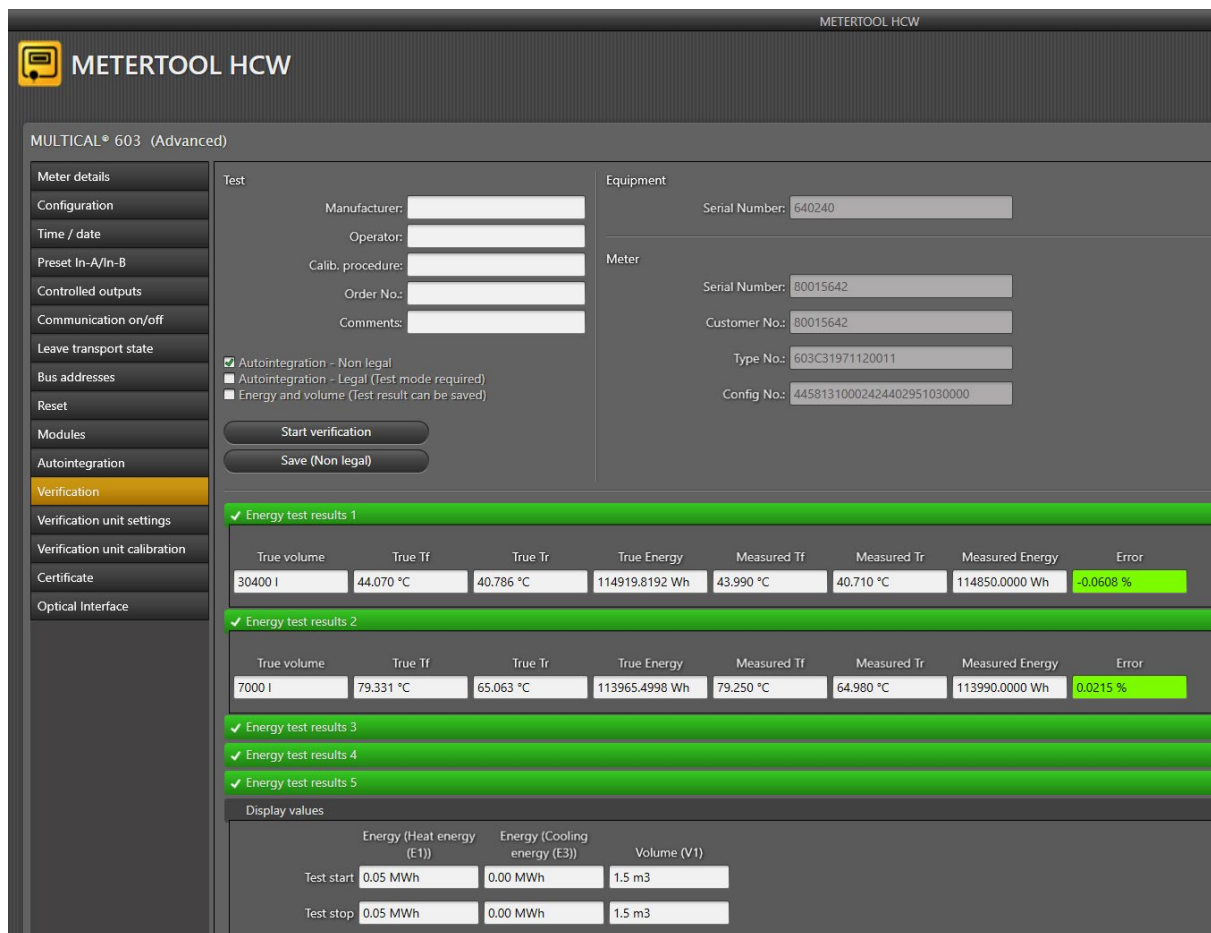

### 2.1 Calibrating MULTICAL® 603

Clicking “Start verification” loads all necessary meter data from MULTICAL® 603 and starts the calibration. Beforehand, it is required to tick off what kind of calibration it should be. The test differences are in respect of the volume simulation:

**Autointegration - Non legal (recommended for on-site use. Requires setup mode. The volume and energy simulated during the calibration will not be accumulated):** Here, the calibration unit uses its microprocessor to calculate the volume so that it corresponds to 100.000 divided by the temperature difference for each test point.

**Autointegration – Legal (recommended for laboratory use. Requires test mode. The volume and energy simulated during the calibration will be accumulated):** In this mode, a higher resolution is accessed and the volume is calculated as 100 L for each test point.

**Energy and volume:** Here, the volume is not calculated by the use of autointegration. Instead, pulses are transmitted from the calibration unit to the meter simulating a real flow sensor. This means that the meter tests both the volume and temperature input. With this test, it is possible to get a calibration certificate.

Both the legal autointegration and the energy and volume calibration can be used by verified laboratories to reverify the meter. The non-legal autointegration can, however, be used as a functional test of the meter.

The results for each test point show the true (simulated) values and the measured values as well as the error between them. As long as the error is within the MPE according to EN1434-1, the field is green. If not, the field is marked red. See section 2.2.4 for a description of the test points.

The amount of test points used depends on the type of meter. A heat meter is calibrated by the first 3 test points while a cooling meter is calibrated by test points 4 and 5. For heat/cooling meters, all 5 of the test points are used.

When the test is completed, the results are displayed in METERTOOL HCW. If the results are acceptable, choose “Save”. The energy test results are then stored in the database under the serial number of the meter.

## 2.2 Verification unit settings

To show data from the calibration unit in METERTOOL, select “Read” under “Verification unit settings”. All the data seen below is then read by the unit.

It is possible to edit these values. But as this data is crucial to the calibration result, it is protected by a password and should only be changed during reverification of the equipment.

Kamstrup can disclose this password upon request.

METER TOOL HCW

MULTICAL® 603 (Advanced)

**Verification Unit**

Serial Number: 640240

Configured: 07/06/2019 10:06:42

Counts: 94  Clear

**Verification**

Avg. room temp.: 23.000

Room temp. range: 5.000

	1st	2nd	3rd	4th	5th	
Permissible Error	1.410	0.700	0.520	1.410	0.710	%
Uncertainty	0.540	0.210	0.024	0.670	0.220	%
Heat Coefficients - Flow Pipe	4.1385	4.0729	3.8326	4.1816	4.1895	MJ / (m³ °C)
Heat Coefficients - Return Pipe	4.1440	4.1077	4.2145	4.1792	4.1820	MJ / (m³ °C)
Number of Integrations	5	4	5	5	5	

**Test Points**

	1st Tf	1st Tr	2nd Tf	2nd Tr	3rd Tf	3rd Tr	4th Tf	4th Tr	5th Tf	5th Tr	T3	
Measured Resistance	585.558	579.221	653.208	625.920	804.620	539.072	529.506	535.891	511.836	539.072	500.000	Ω
True Temperature	44.070	40.786	79.331	65.063	159.650	20.054	15.133	18.417	6.062	20.054	0.000	°C
Nominal Temperature	44.3	41.0	80.0	65.0	160.0	20.0	15.0	18.3	6.0	20.0	0.000000	°C

Buttons: Edit, Write, Read

### 2.2.1 Permissible error and Uncertainty

The permissible error, expressed as a percentage, as well as the measuring uncertainty of the equipment can be seen under each of the five calibration points 1st, 2nd, 3rd, 4th and 5th. The “permissible error” minus “uncertainty” is stated as the MPE on the calibration certificate. According to EN1434-1, the MPE is  $E_c = \pm(0,5 + \Delta\Theta_{min}/\Delta\Theta)$  %.

### 2.2.2 Heat coefficients in inlet and outlet pipe

The heat coefficients used during the computer calculation of the “true” energy are also automatically filled after the use of “Read”. As MULTICAL® 603 uses the heat coefficient from EN1434-1, the same table is naturally used during calibration. Please note that in accordance with EN1434-1, only values from the 16 bar table are used.

## Calibration unit for MULTICAL® 603

### 2.2.3 Number of integrations

The number of energy integrations for each test point is also read automatically and the suitable numbers have been determined for each specific calibration unit type.

### 2.2.4 Test points

Test point	t1/t2	$\Delta\Theta$ [K]
1:	44,3/41°C	3,3
2:	80/65°C	15
3:	160/20°C	140
4:	15/18,3°C	-3,3
5:	6/20°C	-14

Test points are determined by the value of the temperature simulation resistors fitted in the test equipment. Type no. 6699-363/364/365 has the test points shown to the left.

The “true” temperatures are calculated automatically by METERTOOL HCW based on the “Measured resistance” values stored in E<sup>2</sup>prom in the calibration unit.

The negative symbol (-) used for the differential temperature shows the cooling meter usage.

On type no. 6699-363 the temperature of T3 is also measured. This is a simple functional test and is not part of the corresponding test report or calibration certificate. It is, however, displayed in METERTOOL HCW.

### 2.2.5 Measured resistance

To update the calibration of the built-in temperature simulation resistors, type in the new measured values. A calibration sheet listing measured resistance values for all simulation resistors is supplied with the calibration unit by Kamstrup A/S. The temperature simulation resistors should be calibrated once a year or according to local legislation. It is the sole responsibility of the owner/user that the equipment at any given time fulfils local legislation. Please refer to section 2.4 for details concerning the calibration procedure of the equipment.

## 2.3 Test report

This menu is used to print test reports or calibration certificates. A calibration certificate can only be made by verification laboratories with authorized personnel. This document is signed by the authorized person and indicates that the unit is verified. The test report can, however, be made by everyone and shows if the unit is accurate in a non-legal manner.

To make a report, type in the serial number of MULTICAL® 603 for which the report is needed. This requires a saved calibration as described in section 2.1.

You can type in any comment before printing. Click "Print".

An example of the test report and an example of the calibration certificate are shown below:

### Test Report

for MULTICAL® 603

---

Ordered by:  
Address:

---

Make:	Kamstrup A/S	Ambient temperature:	23 °C ± 5 °C
Type:	603D51970020011	Type of test:	
Serial No.:	80015642	Calibration date:	04/10/2021
Config No.:	44581310002424402951030000	Calibrated by:	

---

	True tf [°C]	True tr [°C]	True V [l]	True E [kWh]	Measured E [kWh]	Error [%]	Accept limit	Uncertainty [±%]	MPE [±%]
Test 1	44.07	40.79	30,400.00	114.92	114.85	-0.06	0.87	0.54	1.41
Test 2	79.33	65.06	7,000.00	113.97	113.99	0.02	0.49	0.21	0.70
Test 3	159.65	20.05	700.00	114.40	114.43	0.03	0.50	0.02	0.52
Test 4	15.13	18.42	30,400.00	115.88	116.14	0.22	0.74	0.67	1.41
Test 5	6.06	20.05	7,100.00	115.40	115.44	0.03	0.49	0.22	0.71

Reference equipment S/N: 640240

The true values of temperature and volume are simulated values.

The reported expanded uncertainty of measurements is stated as the standard uncertainty of measurement multiplied by the coverage factor  $k=2$ , which for a normal distribution corresponds to a coverage probability of approximately 95 %.

The verification equipment used is calibrated with traceability of measurement to recognized national or international standards.

---

Data: 14/02/2024    Approved by: \_\_\_\_\_

# Calibration Certificate

for MULTICAL® 603

---

Ordered by:  
Address:

---

Make: Kamstrup A/S                      Ambient temperature: 23 °C ± 5 °C  
Type: 603C31971120011                  Type of test:  
Serial No.: 80015642                      Calibration date: 25/11/2021  
Config No.: 44584310004024202951030000      Calibrated by:

---

	True $t_f$ [°C]	True $t_r$ [°C]	True V [l]	True E [kWh]	Measured E [kWh]	Error [%]	Accept limit	Uncertainty [±%]	MPE [±%]
Test 1	44.07	40.79	36.00	0.14	0.14	-0.14	0.87	0.54	1.41
Test 2	79.33	65.06	18.00	0.29	0.29	0.02	0.49	0.21	0.70
Test 3	159.65	20.05	6.00	0.98	0.98	0.04	0.50	0.02	0.52
Test 4	15.13	18.42	42.00	0.16	0.16	0.06	0.74	0.67	1.41
Test 5	6.06	20.05	18.00	0.29	0.29	0.01	0.49	0.22	0.71

Reference equipment S/N: 640240

The true values of temperature and volume are simulated values.

The reported expanded uncertainty of measurements is stated as the standard uncertainty of measurement multiplied by the coverage factor  $k=2$ , which for a normal distribution corresponds to a coverage probability of approximately 95 %.

The verification equipment used is calibrated with traceability of measurement to recognized national or international standards.

---

Data: 14/02/2024      Approved by: \_\_\_\_\_

## 2.4 Calibration of the equipment

The calibration equipment consists of long-term stable resistance references. Under normal conditions, these require calibration just once a year if used in certified laboratories.

During calibration, use a six- or seven-digit precision ohmmeter with 4-wire connection and traceable calibration. **We recommend that a recognized institute or laboratory calibrates the equipment. Kamstrup also offers traceable re-calibration.**

### 2.4.1 Measuring t1 and t2

t1 and t2 can be measured through the connector J1 of the calibration base with a precision ohmmeter.

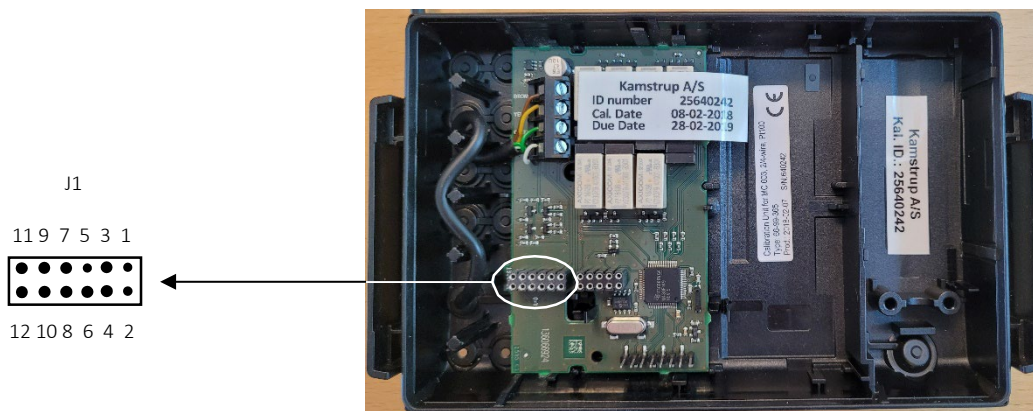

t1: 4-wire: measured between J1 pin 10 and J1 pin 12.

2-wire: measured between J1 pin 8 and pin 10.

t2: 2/4-wire: measured between J1 pin 4 and pin 6.

### 2.4.2 Procedure

To access METERTOOL HCW, it is necessary to use a separate calculator on top of the calibration unit.

1. First, connect the USB plug to the PC.
2. Use “Verification unit calibration” in METERTOOL HCW and tick “Set test point 1”. Now, the relays will adjust the resistors to test point 1 and a measurement can be made with the ohmmeter.
3. Remove the calculator from the calibration unit and connect the precision ohmmeter between pin 10 and 12. This will measure the resistance of the inlet temperature (t1).

Figures below are the Pt500 values and, in parenthesis, the Pt100 values.

Test point 1 = True 1st Tf = 586,002 Ω (117,200 Ω) at t1 = 44,3 °C. Make a note of the measured 1st Tf \_44.3.

4. Now tick “Set test point 2”. It is possible to hear the calibration unit shift its relays when choosing the different test points.

Test point 2 = True 2nd Tf = 654,484 Ω (130,897 Ω) at t1 = 80,0 °C. Make a note of the measured 2nd Tf \_80.0.

## Calibration unit for MULTICAL® 603

Do the same for test points 3, 4 and 5:

Test point 3 = True 3rd Tf = 805,272  $\Omega$  (161,054  $\Omega$ ) at t1 = 160,0 °C. Make a note of the measured 3rd Tf \_160.0.

Test point 4 = True 4th Tf = 529,247  $\Omega$  (105,849  $\Omega$ ) at t1 = 15,0 °C. Make a note of the measured 4th Tf \_15.0.

Test point 5 = True 5th Tf = 511,715  $\Omega$  (102,343  $\Omega$ ) at t1 = 6,0 °C. Make a note of the measured 5th Tf \_6.0.

The same procedure is used to measure the outlet temperature (t2). Connect the precision ohmmeter between pin 4 and 6.

Test point 1 = True 1st Tr = 579,635  $\Omega$  (115,927  $\Omega$ ) at t2 = 41 °C. Make a note of the measured 1st Tr \_41.0.

Test point 2 = True 2nd Tr = 625,800  $\Omega$  (125,160  $\Omega$ ) at t2 = 65,0 °C. Make a note of the measured 2nd Tr \_65.0.

Test point 3 = True 3rd Tr = 538,968  $\Omega$  (107,794  $\Omega$ ) at t2 = 20,0 °C. Make a note of the measured 3rd Tr \_20.0.

Test point 4 = True 4th Tr = 535,664  $\Omega$  (107,133  $\Omega$ ) at t2 = 18,3 °C. Make a note of the measured 4th Tr \_18.3.

Test point 5 = True 5th Tr = 538,968  $\Omega$  (107,794  $\Omega$ ) at t2 = 20,0 °C. Make a note of the measured 5th Tr \_20.0.

Using the “Verification unit settings”, click “Edit” and enter the measured resistance values in the corresponding fields. The true temperature is hereby calculated by the program using the formulas shown in section 2.5.1.

**Please note that a password from Kamstrup is needed to edit the settings in “Verification unit settings”.**

## 2.5 Calculations

During calibration, a series of calculations are continuously carried out. These calculations are used to determine the measured error and are based on the following:

**Volume:** TrueV = Simulated volume during the autointegration, e.g. 100 litres

**Temperature difference:**

$$\Delta\Theta = t1 - t2 \text{ [K]}$$

The formula and method of calculating t1 and t2 can be seen in the next section.

**Heat coefficient:**

Heat coefficient "k" in accordance with EN1434-1.

Volume meter in inlet:

Test point	Test point:		k [MJ/m <sup>3</sup> /K]	k [kWh/m <sup>3</sup> /K]
	t1	t2		
1	44,3 °C	41 °C	4,1381	1,1495
2	80 °C	65 °C	4,0714	1,1310
3	160 °C	20 °C	3,8314	1,0643
4	15 °C	18,3 °C	4,1818	1,1616
5	6 °C	20 °C	4,1896	1,1638

Vol. meter in outlet:

Test point	Test point:		k [MJ/m <sup>3</sup> /K]	k [kWh/m <sup>3</sup> /K]
	t1	t2		
1	44,3 °C	41 °C	4,1437	1,1510
2	80 °C	65 °C	4,1081	1,1411
3	160 °C	20 °C	4,2148	1,1708
4	15 °C	18,3 °C	4,1794	1,1609
5	6 °C	20 °C	4,1822	1,1617

**Energy:**

k from column k [MJ/m<sup>3</sup>/K] is used and the TrueV in litres is used:

$$\text{True E} = \Delta\Theta \text{ TrueV} \times k$$

**Deviation:** Error = (Measured Energy – True Energy)100/True Energy [%]

## Calibration unit for MULTICAL® 603

### 2.5.1 Calculating t1 and t2

The example below shows how t1 and t2 are calculated by the program: In this example, 1st Tf\_44,3 is measured at 586,032 Ω.

Pt500 (Pt100) sensors comply with standard EN 60751

$$R_T = R_0 (1 + A \times T + B \times T^2)$$

$R_T$ : Resistance at a given temperature T

$R_0$ : Resistance at 0 °C for Pt500:  $R_0 = 500 \Omega$  (for Pt100:  $R_0 = 100 \Omega$ )

$A = 0,0039083 \text{ } ^\circ\text{C}^{-1}$

$B = -0,5775 \times 10^{-6} \text{ } ^\circ\text{C}^{-2}$

T can be calculated as follows:

$$T = \frac{(-R_0 \times A) + \sqrt{(R_0 \times A)^2 - 4 \times R_0 \times B \times (R_0 - R_T)}}{2 \times R_0 \times B}$$

With  $R_T = 1st \text{ Tf}_{44,3} = 586,032 \Omega$  inserted in the above formula,  $T = 44,316 \text{ } ^\circ\text{C}$ .

The same method can be used to determine other values.

## 3 Uncertainty

### 3.1 Calculating equipment uncertainty

The following uncertainty calculations are only guiding and based on the equipment being calibrated once a year. It is the choice and responsibility of each verification laboratory.

Uncertainty is calculated according to EA-4/02 M:2013 (Evaluation of the Uncertainty of Measurement In Calibration).

$$E = V \times \Delta\Theta \times k$$

E: Energy

V: Volume

$\Delta\Theta$ : Temperature difference between inlet and outlet pipes

k: Heat coefficient

The uncertainty of  $\Delta\Theta$  (variances of reference resistors type VISHAY S102C) is found. Furthermore, reading of the meter brings about an uncertainty which is included.

Specification via resistors:

TCR Temperature coefficient:  $\pm 2,0$  ppm/ $^{\circ}\text{C}$

1 year's stability:  $\pm 0,005$  %

Thermal EMF:  $0,05$   $\mu\text{V}/^{\circ}\text{C}$  ( $0,1$  ppm/ $^{\circ}\text{C}$  at  $U_{\text{RT}} = 1$  Volt. This point is thus without importance)

### 3.2 Examples of uncertainty calculated for Pt500 type

#### 3.2.1 Points t1 and t2: 15 °C and 18,3 °C

The uncertainty budget calculates the uncertainty at  $\Delta\Theta = -3,3$  °C to be 0,013 K.  
The relative measuring ability is calculated as follows:

$$U_{\%} = \frac{U}{\Delta\Theta} \times 100 [\%]$$

$$U_{\%} = \frac{0,013}{3,3} \times 100 [\%] = 0,39 \%$$

To this, the reading uncertainty of the meter must be added. To keep this fairly low, it is recommended to use 15 integrations. A standard deviation of  $s = 0,25$  % has been found by repetition tests. The expanded coverage factor  $k=2$  makes  $U=0,5$  %.

Thus, combined uncertainty is = %  $\sqrt{0,39^2 + 0,50^2}$  % **U = 0,64 %**

#### 3.2.2 Points t1 and t2: 160 °C and 20 °C

The uncertainty budget calculates the uncertainty at  $\Delta\Theta = 140$  °C to be 0,016 K.  
The relative measuring ability is calculated as follows:

$$U_{\%} = \frac{U}{\Delta\Theta} \times 100 [\%]$$

$$U_{\%} = \frac{0,016}{140} \times 100 [\%] = 0,012 \%$$

To this, the reading uncertainty of the meter must be added. It is recommended to use 1 integration. A standard deviation of  $s = 0,01$  % has been found by repetition tests.  $k=2$  makes  $U=0,02$  %.

Thus, combined uncertainty is = %  $\sqrt{0,012^2 + 0,02^2}$  % **U = 0,023 %**

