

Technical Description

MULTICAL® 402

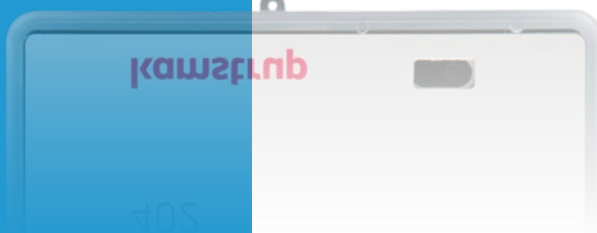

MULTICAL® 402

## Contents

<b>1</b>	<b>General description .....</b>	<b>6</b>
1.1	Mechanical construction.....	7
<b>2</b>	<b>Technical data .....</b>	<b>8</b>
2.1	Approved meter data .....	8
2.2	Electrical data.....	9
2.3	Mechanical data .....	10
2.4	Material.....	11
2.5	Accuracy.....	12
<b>3</b>	<b>Type overview.....</b>	<b>13</b>
3.1	Type and programming overview.....	13
3.2	Type number composition.....	14
3.3	PROG, A-B-CCC .....	16
3.4	Display coding.....	18
3.5	›EE‹ Configuration of MULTITARIFF .....	20
3.6	›FF‹ Input A (VA), pulse division, ›GG‹ Input B (VB), pulse division .....	21
3.7	›PP‹ Output C and Output D.....	24
3.8	Configuration during set up of country code .....	24
<b>4</b>	<b>Dimensioned sketches.....</b>	<b>26</b>
<b>5</b>	<b>Pressure loss.....</b>	<b>29</b>
<b>6</b>	<b>Installation phase.....</b>	<b>30</b>
6.1	Installation requirements.....	30
6.2	Installation angle of MULTICAL® 402 .....	31
6.3	Straight inlet.....	32
6.4	Installation examples .....	33
6.5	Operating pressure of MULTICAL® 402.....	35
6.6	Mounting in forward or return pipe.....	36
6.7	EMC conditions.....	37
6.8	Climatic conditions .....	37
<b>7</b>	<b>Calculator functions.....</b>	<b>38</b>
7.1	Measuring sequences.....	38
7.2	Energy calculation .....	38
7.3	Application types.....	40
7.4	Combined heat/cooling metering.....	42
7.5	Min. and max. flow and power .....	43
7.6	Temperature measurement .....	44
7.7	Display functions.....	45
7.8	Info codes .....	49
7.9	Tariff functions .....	51

7.10	Data loggers .....	55
7.11	Setup via front keys .....	56
7.12	Reset via front keys .....	58
<b>8</b>	<b>Flow Sensor .....</b>	<b>59</b>
8.1	Ultrasound combined with piezo ceramics .....	59
8.2	Principles.....	59
8.3	Transit time method .....	59
8.4	Signal paths .....	61
8.5	Flow limits .....	61
<b>9</b>	<b>Temperature sensors.....</b>	<b>62</b>
9.1	Sensor types.....	63
9.2	Cable influence.....	64
9.3	Installation .....	64
9.4	Pocket sensors .....	65
9.5	Pt500 short direct sensor set .....	66
<b>10</b>	<b>Power supply .....</b>	<b>67</b>
10.1	Built-in 2 x AA-cell lithium battery .....	67
10.2	Built-in D-cell lithium battery.....	68
10.3	Battery lifetimes of 2 x AA-cell.....	69
10.4	Battery lifetimes of D-cell .....	70
10.5	Supply Module 230 VAC.....	71
10.6	Supply Module 24 VAC.....	71
10.7	Change of supply unit .....	72
10.8	Mains cables .....	72
10.9	Danish regulations for the connection of mains operated meters.....	73
<b>11</b>	<b>Communication Modules.....</b>	<b>74</b>
11.1	Communication Modules .....	74
11.2	Pulse outputs (CE and CV).....	75
11.3	Pulse inputs VA and VB.....	76
11.4	Modules .....	77
11.5	Mounting an external antenna.....	81
11.6	Retrofitting modules .....	81
<b>12</b>	<b>Data Communication .....</b>	<b>82</b>
12.1	MULTICAL® 402 Data Protocol .....	82
12.2	Optical eye .....	84
<b>13</b>	<b>Calibration and verification .....</b>	<b>85</b>
13.1	Connector.....	85
13.2	Test – verification mode.....	86
13.3	Handling of different test methods .....	91
13.4	True energy calculation .....	93

<b>14</b>	<b>METER TOOL HCW .....</b>	<b>94</b>
14.1	Introduction.....	94
14.2	METER TOOL HCW for MULTICAL® 402 .....	95
14.3	How to use METER TOOL HCW .....	97
14.4	METER TOOL HCW Settings .....	99
14.5	Verification of MULTICAL® 402 using METER TOOL HCW.....	101
14.6	Flow sensor adjustment.....	104
14.7	LogView HCW.....	106
<b>15</b>	<b>Approvals .....</b>	<b>108</b>
15.1	Type approvals .....	108
15.2	The Measuring Instrument Directive .....	108
<b>16</b>	<b>Troubleshooting .....</b>	<b>110</b>
<b>17</b>	<b>Disposal .....</b>	<b>111</b>
<b>18</b>	<b>Documents .....</b>	<b>112</b>

# 1 General description

MULTICAL® 402 is a static heat meter, cooling meter or combined heat/cooling meter based on the ultrasonic principle. The meter is intended for energy measurement in almost all types of thermal installations where water is used as the energy-conveying medium.

According to EN 1434 MULTICAL® 402 can be designated a "hybrid instrument" also called a compact meter. In practice this means that flow sensor and calculator must not be separated.

If flow sensor and calculator have been separated and the seals, therefore, broken, the meter is no longer valid for billing purposes. Furthermore, the factory guarantee no longer applies.

MULTICAL® 402 employs ultrasonic measuring techniques, ASIC and microprocessor technology. All calculating and flow measuring circuits are collected on one single board, thus providing a compact and rational design and, in addition, exceptionally high measuring accuracy and reliability is obtained.

The volume is measured using bidirectional ultrasonic technique based on the transit time method, proven a long-term stable and accurate measuring principle. Two ultrasonic transducers are used to send sound signals both against and with the flow. The ultrasonic signal travelling with the flow reaches the opposite transducer first. The time difference between the two signals can be converted into flow velocity and thereby also volume.

Accurately matched Pt500 or Pt100 sensors measure the temperatures in forward and return pipes according to EN 60751. MULTICAL® 402 is available with a set of Pt500 sensors, either short direct sensors according to EN 1434-2 or D 5.8 mm pocket sensors which fit Kamstrup's stainless steel sensor pockets.

The accumulated heat energy and/or cooling energy can be displayed in kWh, MWh, GJ or in Gcal, all in the form of seven significant digits and a measuring unit. The display has been specially designed to obtain long lifetime and sharp contrast in a wide temperature range.

Other possible readings are: accumulated water consumption, operating hour counter, current temperature measurements, current flow and power readings. Furthermore, MULTICAL® 402 can be configured to display monthly and yearly loggings, target date data, max./min. flow, max./min. power, information code, current date as well as user-defined tariffing.

MULTICAL® 402 is powered by an internal D-cell lithium battery with a lifespan of up to 16 years or a 2xAA lithium packet with a lifespan of up to 6 years. Alternatively, the meter can be mains supplied, either by 24 VAC or 230 VAC.

In addition to the energy meter's own data MULTICAL® 402 can display the accumulated consumptions of two extra water meters, e.g. cold and hot water meters, which supply a contact signal to MULTICAL® 402 via reed-switch or electronic output. The contact signals from the extra water meters are connected via the communication modules.

A multiple plug placed beneath the seal is used in connection with calibration and adjustment during verification as well as in connection with communication modules. MULTICAL® 402 is available with communication modules for Radio, M-Bus and RS232.

In designing MULTICAL® 402 we have attached great importance to flexibility through programmable functions and plug-in modules (see paragraph 11 and 14) in order to secure optimum use in a wide range of applications. In addition, the construction makes it possible to update previously installed MULTICAL® 402 via the PC-program METERTOOL.

This technical description has been written with a view to enabling operations managers, meter installers, consulting engineers and distributors to utilize all functions comprised in MULTICAL® 402. Furthermore, the description is directed to laboratories performing tests and verification.

## 1.1 Mechanical construction

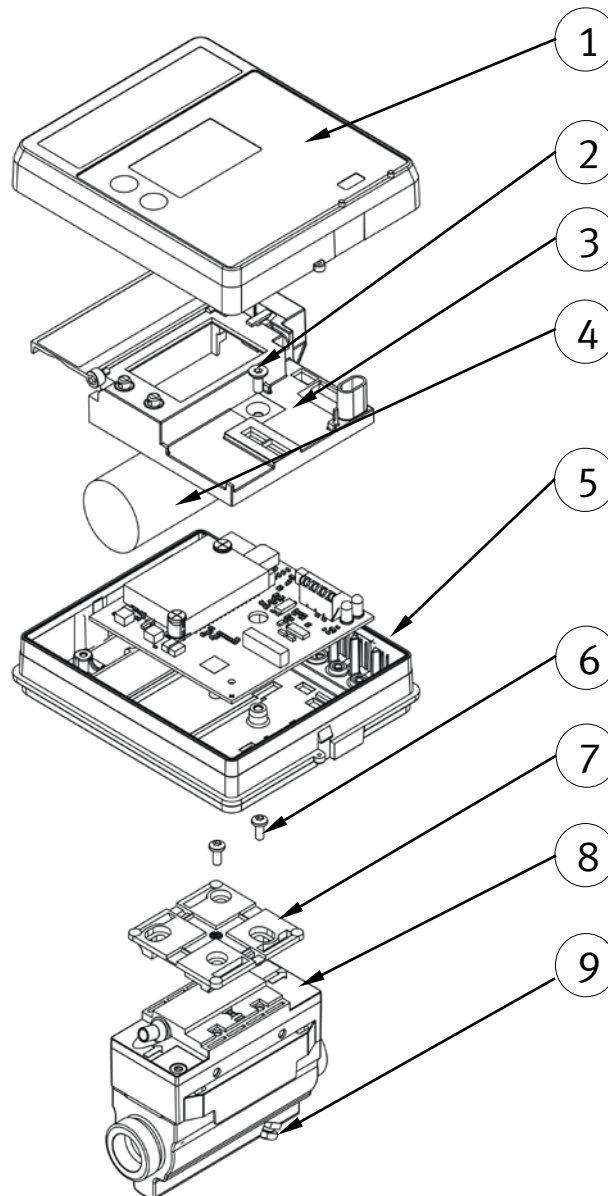

Figure 1

- 1 Transparent top cover with front plate
- 2 Sealing screw for verification cover
- 3 Verification cover incl. pushbuttons. The supply unit's cover can be opened without breaking the verification seal
- 4 Supply: D-cell or 2xAA-cell batteries, 24 VAC or 230 VAC. Can be replaced without breaking the verification seal.
- 5 Cabinet for electronics unit
- 6 Screws for fitting
- 7 Fitting. Is also applicable for wall mounting
- 8 Meter case with holes for cable retainers (cable retainers: 1650-145)
- 9 Sensor connecting piece and blind plug for short direct sensor

## 2 Technical data

### 2.1 Approved meter data

Approvals	DK-0200-MI004-013	
Standards	prEN 1434:2009	
EU directives	Measuring Instrument Directive, Low Voltage Directive, Electromagnetic Compatibility Directive, Pressurised equipment Directive	
Heat meter approval	DK-0200-MI004-013	
Temperature range	θ: 2°C...160°C	The stated minimum temperatures apply to the type approval only.
Differential range	Δθ: 3 K...150 K	The meter has no cutoff for low temperature and thus measures as low temperatures as 0.01°C and 0.01 K.
Cooling meter		
Temperature range	θ: 2°C...50°C	
Differential range	Δθ: 3 K...40 K	
Accuracy		
- Calculator	$E_c = \pm (0.5 + \Delta\theta_{min}/\Delta\theta) \%$	
- Flow sensor	$E_f = \pm (2 + 0.02 q_p/q)$ , but not exceeding $\pm 5 \%$	
Temperature sensors	-Type 402-V Pt100 – EN 60 751, 2-wire connection -Type 402-W/T Pt500 – EN 60 751, 2-wire connection	
EN 1434 designation	Environmental class A	
MID designation	Mechanical environment: Class M1 Electromagnetic environment: Class E1 Non-condensing environment, closed location (indoors), 5...55°C °C	

<b>Type number</b>	Nom. flow q <sub>p</sub> [ m <sup>3</sup> /h ]	Max. flow q <sub>s</sub> [ m <sup>3</sup> /h ]	Min. flow q <sub>i</sub> [ l/h ]	Min. cutoff [ l/h ]	Pressure loss Δp @ q <sub>p</sub> [ bar ]	Connection on meter	Length [ mm ]
402xxxxxx1xxx	0.6	1.2	6	3	0.04	G <sup>3</sup> /4B	110
402xxxxxx3xxx	0.6	1.2	6	3	0.04	G1B	190
402xxxxxx4xxx	1.5	3.0	15	3	0.25	G <sup>3</sup> /4B	110
402xxxxxx5xxx	1.5	3.0	15	3	0.25	G <sup>3</sup> /4B	165
402xxxxxx7xxx	1.5	3.0	15	3	0.25	G1B	130
402xxxxxx8xxx	1.5	3.0	15	3	0.25	G1B	165
402xxxxxx9xxx	1.5	3.0	15	3	0.25	G1B	190
402xxxxxxAxxx	2.5	5.0	25	5	0.03	G1B	130
402xxxxxxBxxx	2.5	5.0	25	5	0.03	G1B	190
402xxxxxxDxxx	3.5	7.0	35	7	0.07	G5/4B	260
402xxxxxxFxxx	6.0	12	60	12	0.19	G5/4B	260
402xxxxxxGxxx	6.0	12	60	12	0.19	DN25	260
402xxxxxxHxxx	10	20	100	20	0.06	G2B	300
402xxxxxxJxxx	10	20	100	20	0.06	DN40	300
402xxxxxxKxxx	15	30	150	30	0.14	DN50	270

Table 1

## 2.2 Electrical data

### Calculator data

Typical accuracy                      Calculator:  $E_c \pm (0.15 + 2/\Delta\Theta) \%$     Sensor set:  $E_T \pm (0.4 + 4/\Delta\Theta) \%$

Display                                    LCD – 7 (8) digits with digit height 7.6 mm

Resolution                                9999,999 – 99999,99 – 999999,9 – 9999999

Energy units                                MWh – kWh – GJ – Gcal

Data logger (Eeprom)                    460 days, 36 months, 15 years, 50 info codes

Clock/calendar                            Clock, calendar, leap year compensation, target date

Data communication                      KMP protocol with CRC16 used for optical communication as well as modules.

Power of temperature sensors            < 10  $\mu$ W RMS

**Supply voltage**                            3.6 VDC  $\pm$  0.1 VDC

**Battery**                                      3.65 VDC, D-cell lithium                      3.65 VDC, 2xAA cell lithium

Replacement interval

- Wall mounted                              16 years @  $t_{BAT} < 30 \text{ }^\circ\text{C}$                       6 years @  $t_{BAT} < 30 \text{ }^\circ\text{C}$

- Mounted on flow sensor                    12 years @  $t_{BAT} < 40 \text{ }^\circ\text{C}$                       5 years @  $t_{BAT} < 40 \text{ }^\circ\text{C}$

Data modules, frequent data communication and high ambient temperature reduce the replacement interval (See paragraph 10.3 and 10.4)

**Mains supply**                                230 VAC  $\pm 15/-30\%$ , 50/60 Hz  
24 VAC  $\pm 50\%$ , 50/60 Hz

Insulation voltage                            4 kV

Power consumption                            < 1W

Backup supply                                Integral SuperCap eliminates interruptions due to short-term power failures

EMC data                                      Fulfil EN 1434 class A (MID class E1)

### Temperature measurement

		<b>T1 Forward temperature</b>	<b>T2 Return temperature</b>	<b><math>\Delta\Theta</math> (T1-T2) Heat metering</b>	<b><math>\Delta\Theta</math> (T2-T1) Cooling metering</b>
<b>402-V 2-W Pt100</b>	Measuring range	0.00...165.00 $^\circ\text{C}$	0.00...165.00 $^\circ\text{C}$	0.01...165.00K	0.01...165.00K
<b>402-W/T 2-W Pt500</b>	Measuring range	0.00...165.00 $^\circ\text{C}$	0.00...165.00 $^\circ\text{C}$	0.01...165.00K	0.01...165.00K

### Max. cable lengths

(Max.  $\varnothing$ 6 mm cable)

#### Pt100, 2-wire

2 x 0.25 mm<sup>2</sup>: 2.5 m

2 x 0.50 mm<sup>2</sup>: 5 m

2 x 1.00 mm<sup>2</sup>: 10 m

#### Pt500, 2-wire

2 x 0.25 mm<sup>2</sup>: 10 m

2 x 0.50 mm<sup>2</sup>: 20 m

# MULTICAL® 402

## Pulse inputs VA and VB

VA: 65-66 and VB: 67-68 via module

Pulse input

Pulse ON

Pulse OFF

Pulse frequency

Electrical isolation

Max. cable length

Requirements to ext. contact

Water meter connection

FF(VA) and GG(VB) = 01...40

680 k $\Omega$  pull-up to 3.6 V

< 0.4 V in > 30 ms.

> 2.5 V in > 1.1 s.

< 0.5 Hz

None

25 m

Leak current at function open < 1  $\mu$ A

## Pulse outputs CE and CV

CE: 16-17 and CV 18-19 via module

Type

Pulse duration

External voltage

Current

Residual stress

Electrical isolation

Max. cable length

Open collector (OB)

Optionally 32 ms. or 100 ms.

5...30 VDC

1...10 mA

$U_{CE} \approx 1$  V at 10 mA

2 kV

25 m

## 2.3 Mechanical data

Environmental class

Ambient temperature

Protection class

Fulfils EN 1434 class A (MID class E1)

5...55°C, non-condensing, closed location (installation indoors)

Calculator: IP54

Flow sensor: IP65

## Medium temperatures

Heat meters 402-V/W

Cooling meters 402-T

Heat/cooling meters 402-T

Medium in flow meter

Storage temperature

Pressure stage (with thread)

Pressure stage (with flange)

Weight

Flow sensor cable

Connecting cables

Supply cable

15...130°C  
°C

2...50°C°C

2...130

Water

-25...60°C°C (drained flow sensor)

PN16

PN25

From 1.8 to 12 kgs. depending on flow meter size

1.5 m (cable undemountable)

ø3.5...6 mm

ø5...10 mm

At medium temperatures above 90°C in flow sensor, use of flange meters is recommended, and the calculator should be wall-mounted.

## 2.4 Material

Wetted parts	Case, gland	DZR brass (Dezincificationproof brass)
	Case, flange	Stainless steel, W.no. 1,4308
	Transducer	Stainless steel, W.no. 1,4401
	Gaskets	EPDM
	Measuring tube	Thermoplastic, PES 30% GF
	Reflectors	Thermoplastic, PES 30% GF and Stainless steel, W.no. 1,4301
Flow sensor case	Top/wall fittings	Thermoplastic, PC 20% GF
Calculator case	Top	Thermoplastic, PC
	Base	Thermoplastic, ABS with TPE gaskets (thermoplastic elastomer)
	Internal cover	Thermoplastic, ABS
Flow sensor cable	Silicone cable with inner Teflon insulation	

## 2.5 Accuracy

Heat meter components	MPE according to EN 1434-1	MULTICAL® 402, typical accuracy
Flow sensor	$E_f = \pm (2 + 0.02 q_p/q)$ , but not exceeding $\pm 5\%$	$E_f = \pm (1 + 0.01 q_p/q)\%$
Calculator	$E_c = \pm (0.5 + \Delta\Theta_{\min}/\Delta\Theta)\%$	$E_c = \pm (0.15 + 2/\Delta\Theta)\%$
Sensor pair	$E_t = \pm (0.5 + 3 \Delta\Theta_{\min}/\Delta\Theta)\%$	$E_t = \pm (0.4 + 4/\Delta\Theta)\%$

MULTICAL® 402  $q_p$  1,5 m<sup>3</sup>/h @ $\Delta\Theta$  30K

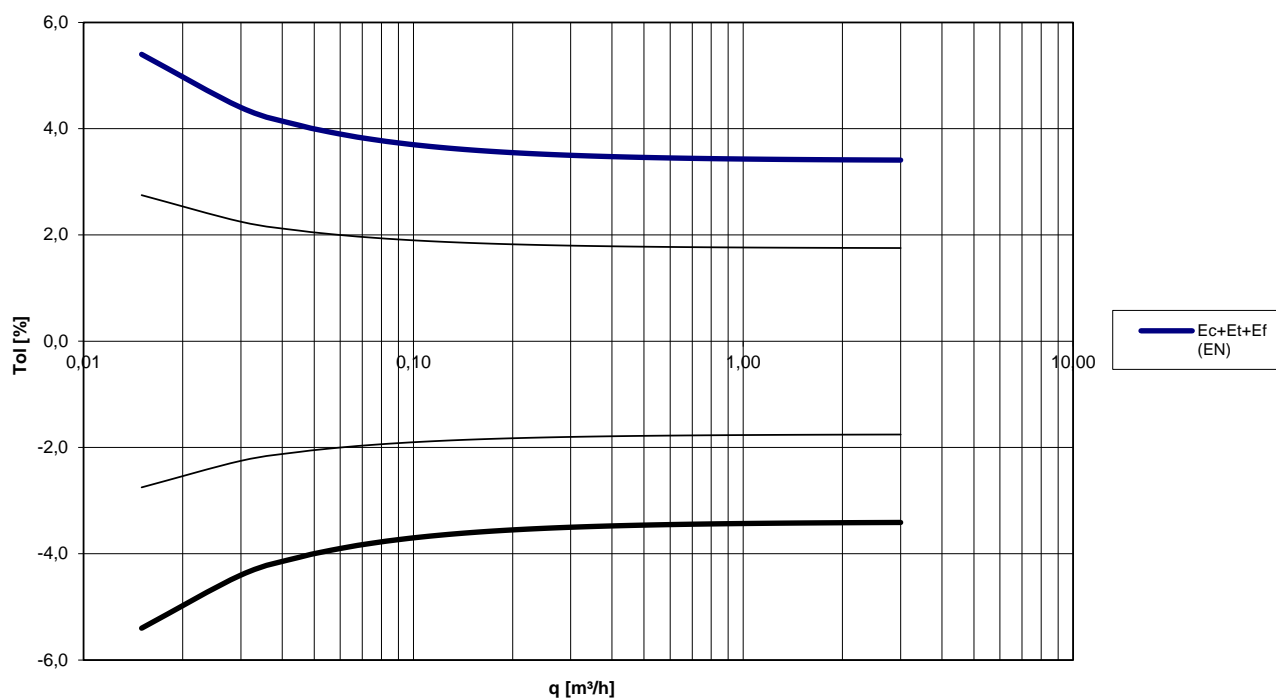

Diagram 1: Total typical accuracy of MULTICAL® 402 compared to EN 1434-1

### 3 Type overview

MULTICAL® 402 can be ordered in many combinations as required by the customer. First you select the required hardware from the type overview. Then select "Prog", "Config" and "Data" to suit the application in question.

The supplied meter is configured from the factory and ready for use, however it can also be changed/reconfigured after installation.

Please note that the points marked "Total prog" cannot be changed without breaking the verification seal. This means that the change must be carried out by an accredited meter laboratory.

We currently develop new functions and modules for MULTICAL® 402. Please contact Kamstrup A/S if your application is not covered by the variants shown.

#### 3.1 Type and programming overview

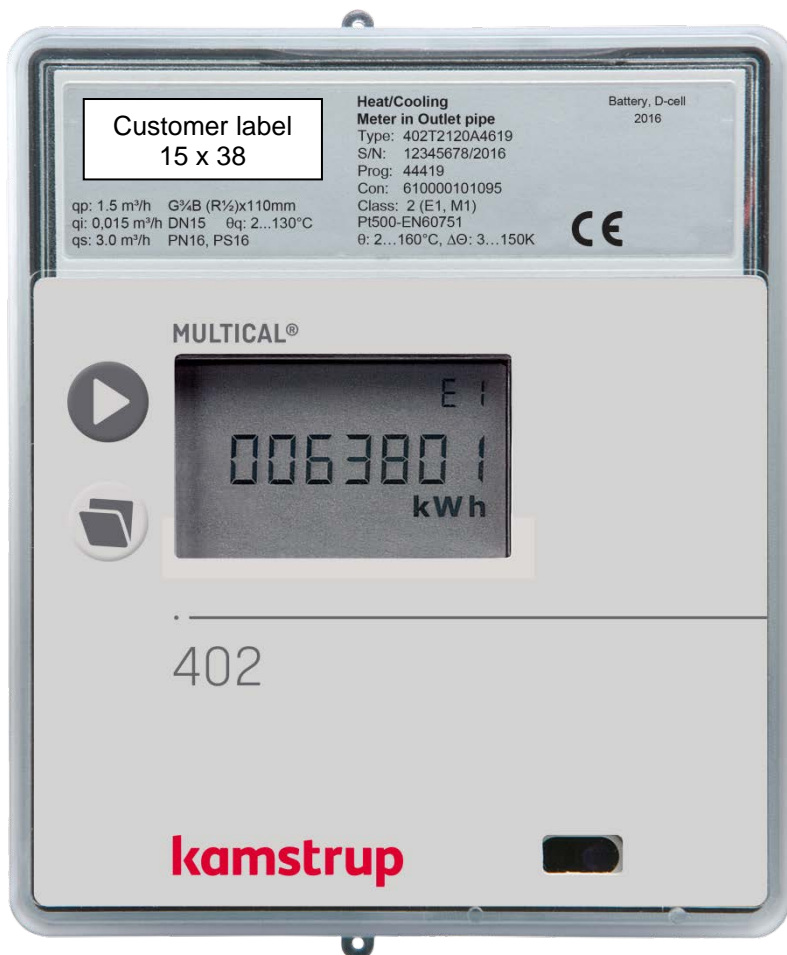

##### **Type number 402xxxxxxxxx (Total prog)**

Selection of Pt100/Pt500 calculator, modules, supply, sensor set, flow sensor and language on label

##### **Prog. A-B-CCC (Total prog)**

Forward/return – Energy unit – Flow meter code

##### **Config. DDD-EE-FF-GG-N-PP (Partial prog)**

Display – Tariff – Pulse inputs  
Leak sensibility – Pulse outputs

##### **Data: (Partial prog.)**

- Customer No.
- Target date
- Tariff limits
- Average peak time max./min.
- Heat/cooling switching
- Date/time

### 3.2 Type number composition

	Type	402-	□	□□	□	□□	□	□	□□
<b>Sensor connections</b>									
Pt100			V						
Pt500			W						
Pt500 (with condensation protected flow sensor for cooling)			T						
<b>Modules</b>									
No module				00					
Data + 2 pulse inputs (VA, VB)				10					
Data + 2 pulse outputs (CE, CV)				11					
M-Bus + 2 pulse inputs (VA, VB)				20					
M-Bus + 2 pulse outputs (CE, CV)				21					
M-Bus + 2 pulse inputs (VA, VB), MCIII Data Package				29					
Wireless M-Bus, EU, 868 MHz, Mode C1 (Ind. Key)				30					
Wireless M-Bus, EU, 868 MHz, Mode T1 OMS (Ind. Key)				31					
Wireless M-Bus, EU, 868 MHz, Mode C1 (Ind. Key) Alt. Reg. +VA, VB				35					
Wireless M-Bus, EU, 868 MHz, Mode T1 (Common Key)				37					
Wireless M-Bus, C1, Fixed Network, (Ind. Key)				38					
Radio, EU, 434 MHz, int. ant., NET0				40					
Radio, EU, 434 MHz, int. ant., NET1				41					
Radio, EU, 434 MHz, int.+ext. ant., NET0 + 2 pulse inputs (VA, VB)				42					
Radio, EU, 434 MHz, int.+ext. ant., NET0 + 2 pulse outputs (CE, CV)				43					
Radio, EU, 434 MHz, int.+ext. ant., NET1 + 2 pulse inputs (VA, VB)				44					
Radio, EU, 434 MHz, int.+ext. ant., NET1 + 2 pulse outputs (CE, CV)				45					
Radio, SE, 444 MHz, int. ant., NET0 + 2 pulse inputs (VA, VB)				50					
Radio, SE, 444 MHz, int. ant., NET1 + 2 pulse inputs (VA, VB)				52					
Radio, SE, 444 MHz, ext. ant., NET0 + 2 pulse inputs (VA, VB)				54					
Radio, SE, 444 MHz, ext. ant., NET1 + 2 pulse inputs (VA, VB)				56					
<b>Supply</b>									
No module							0		
Battery, 2 x AA							1		
Battery, D-cell							2		
230 VAC supply module							7		
24 VAC supply module							8		
<b>Pt500 sensor sets</b>									
No sensor set								00	
Pocket sensor pair with 1.5 m cable								0A	
Pocket sensor set with 3.0 m cable								0B	
Short direct sensor set with 1.5 m cable								0F	
Short direct sensor set with 3.0 m cable								0G	
<b>Flow sensor qp</b>	<b>Connection</b>	<b>Length [mm]</b>	<b>CCC Heat</b>	<b>CCC Cooling</b>					
0,6	G¾B (R½)	110	416	416					1
0,6	G1B (R¾)	190	416	416					3
1,5	G¾B (R½)	110	419	407					4
1,5	G¾B (R½)	165	419	407					5
1,5	G1B (R¾)	130	419	407					7
1,5	G1B (R¾)	165	419	407					8
1,5	G1B (R¾)	190	419	407					9
2,5	G1B (R¾)	130	498	498					A
2,5	G1B (R¾)	190	498	498					B
3,5	G5/4B (R1)	260	451	436					D
6,0	G5/4B (R1)	260	437	438					F
6,0	DN25	260	437	438					G
10	G2B (R1½)	300	478	483					H
10	DN40	300	478	483					J
15	DN50	270	420	485					K
<b>Meter type</b>									
Heat meter	(MID: module B+D)								2
Heat meter	(MID: module B+D)			402-T only					3
Heat meter									4
Cooling meter				402-T only					5
Heat/cooling meter				402-T only					6
Volumemeter	(Hot)								7
Volumemeter	(Cold)			402-T only					8
Energy meter									9
<b>Country code (language on label etc.)</b>									<b>XX</b>

Contact Kamstrup for information on the availability of the above MULTICAL® 402 variants on the individual markets.

### 3.2.1 Accessories

402-000-1000-000	Battery module with two AA-cells
402-000-2000-000	D-cell battery
402-000-7000-000	230 VAC supply module
402-000-8000-000	24 VAC supply module
66-99-097	USB-cable with galvanic separation
66-99-099	Infrared optical reading head w/USB plug
66-99-102	Infrared optical reading head RS232 w/D-sub 9F
66-99-106	Data cable RS232, D-sub 9F
66-99-108	PC-Interface cable RS232, for MULTICAL®
66-99-372	Pt500 (Heat) Verification unit for MC402 (to be used with METERTOOL)
66-99-373	Pt500 (Cooling) Verification unit for MC402 (to be used with METERTOOL)
66-99-724	METERTOOL for HCW
66-99-725	LogView for HCW

### Glands including gaskets (PN16)

Material: Copper alloy brass, CW617N (nipple). Copper alloy brass, CW602N (coupling)

Glands				
Size	Nipple	Union	Type no.	2 nos.
DN15	R $\frac{1}{2}$	G $\frac{3}{4}$	-	6561-323
DN20	R $\frac{3}{4}$	G1	-	6561-324
DN25	R1	G5/4	6561-325	
DN40	R1 $\frac{1}{2}$	G2	6561-315	

Material: Reinz AFM30

Gaskets for glands	
Size (union)	Type no.
G $\frac{3}{4}$	2210-061
G1	2210-062
G5/4	2210-063
G2	2210-065

Material: Reinz AFM34

Gaskets for flange meters PN25	
Size	Type no.
DN20	2210-147
DN25	2210-133
DN40	2210-132
DN50	2210-099

Contact Kamstrup A/S about further accessories.

### 3.3 PROG, A-B-CCC

The meter’s legal parameters are determined by the Prog, which cannot be changed without breaking the verification seal. This means that the change must be made by an accredited laboratory.

**The A-code** indicates whether the flow sensor is mounted in forward or return pipe. As the density and specific heat capacity of water increases with temperature, the calculator must correct for the installation type in question.

Wrong programming or installation will result in measuring errors. Further details concerning installation of flow sensor in flow or return for heat and cooling meters appear from paragraph 6.6.

**The B-code** indicates the measuring unit used in the energy register. GJ, kWh or MWh are the most frequently used units, whereas Gcal are only used in a few countries outside the EEA.

**The CCC-code** optimizes the display resolution for the selected flow sensor size at the same time as the type approval regulations as to minimum resolution and maximum register overflow are obeyed. The CCC-codes are divided into two tables for standard resolution and high resolution respectively.

Prog. number	A	-	B	-	CCC
	□		□		□□□
<b>Flow sensor position:</b>					
k-factor - Forward (at T1)	3				
table - Return (at T2)	4				
<b>Measuring unit, Energy</b>					
- GJ			2		
- kWh			3		
- MWh			4		
- Gcal			5		
<b>Flow sensor coding (CCC-table)</b>					CCC

## 3.3.1 Standard CCC-codes

CCC-table for MULTICAL® 402									
CCC No.	Number of decimals in display							qp [m³/h]	Type 402-xxxx-xxX-xxx
	kWh	MWh Gcal	GJ	m³	l/h	m³/h	kW		
416	0	3	2	2	0	-	1	0.6	1-3
419	0	3	2	2	0	-	1	1.5	4-5-7-9
498	0	3	2	2	0	-	1	2.5	A-B
451	-	2	1	1	0	-	1	3.5	D
437	-	2	1	1	0	-	1	6.0	F-G
478	-	2	1	1	0	-	1	10	H-J
420	-	2	1	1	0	-	1	15	K
490	-	1	0	0	0	-	1	15	K



## 3.3.2 CCC-codes with high resolution



CCC-table for MULTICAL® 402									
CCC No.	Number of decimals in display							qp [m³/h]	Type 402-xxxx-xxX-xxx
	kWh	MWh Gcal	GJ	m³	l/h	m³/h	kW		
484	1	-	3	3	0	-	1	0.6	1-3
407	1	-	3	3	0	-	1	1.5	4-5-7-9
455	1	-	3	2	0	-	1	1,5	4-5-6-7-8-9
454	1	-	3	3	0	-	1	2.5	A-B
459	1	-	3	2	0	-	1	2,5	A-B
436	0	3	2	2	0	-	1	3.5	D
438	0	3	2	2	0	-	1	6.0	F-G
483	0	3	2	2	0	-	1	10	H-J
485	0	3	2	2	0	-	1	15	K

The use of CCC-codes with high resolution reduces the battery lifetime if you choose modules with pulse outputs.

### 3.4 Display coding

Display code "DDD" indicates the active readings of each meter type. "1" is the first primary reading, whereas e.g. "1A" is the first secondary reading. The display automatically returns to reading "1" after 4 minutes.

				Date Stamp	Heat meter DDD=210	Heat meter DDD=410	Cooling meter DDD=510	Heat/cooling DDD=610	Volume/Heat DDD=710	Volume/Cool DDD=810	Energy meter DDD=910
											
<b>1.0</b>	<b>Heat energy (E1)</b>				<b>1</b>	<b>1</b>		<b>1</b>			<b>1</b>
		1.1	Yearly data	•	1A	1A		1A			
		1.2	Monthly data	•	1B	1B		1B			1A
<b>2.0</b>	<b>Cooling energy (E3)</b>						<b>1</b>	<b>2</b>			
		2.1	Yearly data	•			1A	2A			
		2.2	Monthly data	•			1B	2B			
<b>2.PM</b>	<b>High-resolution energy (verification mode only)</b>				1PM	1PM	1PM	1PM			
<b>3.X</b>	<b>Other energy types</b>										
		3.6	E8 (m3*tf)		<b>2</b>	<b>2</b>					
		3.7	E9 (m3*tr)		2A	2A					
<b>4.0</b>	<b>Volume V1</b>				<b>3</b>	<b>3</b>	<b>2</b>	<b>3</b>	<b>1</b>	<b>1</b>	<b>2</b>
		4.1	Yearly data	•	3A	3A	2A	3A	1A	1A	
		4.2	Monthly data	•	3B	3B	2B	3B	1B	1B	2A
<b>4.PM</b>	<b>Volume - High-resolution (verification mode only)</b>				3PM	3PM	2PM	3PM			
<b>6.0</b>	<b>Hour counter</b>				<b>4</b>	<b>4</b>	<b>3</b>	<b>4</b>	<b>2</b>	<b>2</b>	<b>3</b>
<b>7.0</b>	<b>T1 (Flow)</b>				<b>5</b>	<b>5</b>	<b>4</b>	<b>5</b>			<b>4</b>
		7.1	Year-to-date average		5A	5A	4A	5A			
		7.2	Month-to-date average		5B	5B	4B	5B			
<b>8.0</b>	<b>T2 (Return)</b>				<b>6</b>	<b>6</b>	<b>5</b>	<b>6</b>			<b>5</b>
		8.1	Year-to-date average		6A	6A	5A	6A			
		8.2	Month-to-date average		6B	6B	5B	6B			
<b>9.0</b>	<b>T1-T2 (Δt) - = cooling</b>				<b>7</b>	<b>7</b>	<b>6</b>	<b>7</b>			<b>6</b>
<b>12.0</b>	<b>Flow (V1)</b>				<b>8</b>	<b>8</b>	<b>7</b>	<b>8</b>	<b>3</b>	<b>3</b>	<b>7</b>
		12.1	This year's max.	•	8A	8A	7A	8A	3A	3A	
		12.2	Max. yearly data	•							
		12.3	This year's min.	•							
		12.4	Min. yearly data	•							
		12.5	This month's max.	•							
		12.6	Max. monthly data	•	8B	8B	7B	8B	3B	3B	7A
		12.7	This month's min.	•							
		12.8	Min. monthly data	•	8C	8C	7C	8C	3C	3C	7B
<b>14.0</b>	<b>Power (V1)</b>				<b>9</b>	<b>9</b>	<b>8</b>	<b>9</b>			<b>8</b>
		14.1	This year's max.	•	9A	9A	8A	9A			
		14.2	Max. yearly data	•							
		14.3	This year's min.	•							
		14.4	Min. yearly data	•							
		14.5	This month's max.	•							
		14.6	Max. monthly data	•	9B	9B	8B	9B			
		14.7	This month's min.	•							
		14.8	Min. monthly data	•	9C	9C	8C	9C			

				Date Stamp	Heat meter DDD=210	Heat meter DDD=410	Cooling meter DDD=510	Heat/cooling DDD=610	Volume/Heat DDD=710	Volume/Cool DDD=810	Energy meter DDD=910
											
<b>15.0</b>	<b>VA (Input A)</b>				<b>10</b>	<b>10</b>	<b>9</b>	<b>10</b>	<b>4</b>	<b>4</b>	<b>9</b>
		15.1	Meter No. VA		10A	10A	9A	10A	4A	4A	9A
		15.2	Yearly data	•	10B	10B	9B	10B	4B	4B	9B
		15.3	Monthly data	•	10C	10C	9C	10C	4C	4C	9C
<b>16.0</b>	<b>VB (Input B)</b>				<b>11</b>	<b>11</b>	<b>10</b>	<b>11</b>	<b>5</b>	<b>5</b>	<b>10</b>
		16.1	Meter No. VB		11A	11A	10A	11A	5A	5A	10A
		16.2	Yearly data	•	11B	11B	10B	11B	5B	5B	10B
		16.3	Monthly data	•	11C	11C	10C	11C	5C	5C	10C
<b>17.0</b>	<b>TA2</b>				<b>12</b>	<b>12</b>		<b>12</b>			
		17.1	TL2		12A	12A					
<b>18.0</b>	<b>TA3</b>				<b>13</b>	<b>13</b>		<b>13</b>			
		18.1	TL3		13A	13A					
<b>19.0</b>	<b>Info Code</b>				<b>14</b>	<b>14</b>	<b>11</b>	<b>14</b>	<b>6</b>	<b>6</b>	<b>11</b>
		19.1	Info event counter		14A	14A	11A	14A	6A	6A	11A
		19.2	Info logger (36 latest events)	•	14B	14B	11B	14B	6B	6B	11B
<b>20.0</b>	<b>Customer number (N° 1+2)</b>				<b>15</b>	<b>15</b>	<b>12</b>	<b>15</b>	<b>7</b>	<b>7</b>	<b>12</b>
		20.1	Date		15A	15A	12A	15A	7A	7A	12A
		20.2	Hour		15B	15B	12B	15B	7B	7B	12B
		20.3	Target date		15C	15C	12C	15C	7C	7C	12C
		20.4	Serial no. (N° 3)		15D	15D	12D	15D	7D	7D	12D
		20.5	Prog. (A-B-CCC) (N° 4)		15E	15E	12E	15E	7E	7E	12E
		20.6	Config 1 (DDD-EE) (N° 5)		15F	15F	12F	15F	7F	7F	12F
		20.7	Config 2 (FF-GG-N-PP) (N° 6)		15G	15G	12G	15G	7G	7G	12G
		20.8	Software edition (N° 10)		15H	15H	12H	15H	7H	7H	12H
		20.9	Software check sum (N° 11)		15I	15I	12I	15I	7I	7I	12I
		20.10	Segment test		15J	15J	12J	15J	7J	7J	12J
		20.15	M-Bus primary adr. (N° 31)		15K	15K	12K	15K	7K	7K	12K
		20.16	M-Bus secondary adr. (N° 32)		15L	15L	12L	15L	7L	7L	12L

Number of yearly data displayed (1... 15)		2	2	2	2	2	2	2	2
Number of monthly data displayed (1... 36)		12	12	12	12	12	12	12	12

DDD=210 is the "standard code" of heat meters with meter type 402xxxxxx2xx. Please contact Kamstrup for other combinations. A DDD-code can contain max. 103 readings including 4 data logger counts.

A total survey of existing display codes (DDD) appear from a separate document.

Please contact Kamstrup for further details.

PM are indications which only appear in verification mode.

Note: Data reading can collect up to 36 monthly data and up to 15 yearly data. The number of displayed yearly and monthly data is determined by the DDD-code.

### 3.4.1 Energy overview

The above-mentioned energy types E1, E3, E8 and E9 are calculated as follows:

Formula	Example of application	Condition	
$E1=V1(T1-T2)$	Heat energy (V1 in flow or return) $T1 > T2$	$T1 > \theta_{hc}$ (Forward temperature must be higher than the limit value)	Legal Display/Data/Log
$E3=V1(T2-T1)$	Cooling energy (V1 in flow or return) $T2 > T1$	$T1 > \theta_{hc}$ (Forward temperature must be lower than the limit value)	Legal Display/Data/Log
$E8=m^3 \times T1$	Used for calculation of average temperature of forward pipe	None	Display/Data/Log
$E9=m^3 \times T2$	Used for calculation of average temperature of return pipe	None	Display/Data/Log

$\theta_{hc}$  is the temperature, at which the meter shifts between heat and cooling measurement. The typical value is 25°C, but other values can be supplied as required.

If  $\theta_{hc}$  is set at 180°C the function is disconnected, e.g. to be used for "purchase/sales" of heat. See paragraph 7.4 for further information on heat/cooling meters.

### 3.5 >EE< Configuration of MULTITARIFF

MULTICAL® 402 has 2 extra registers, TA2 and TA3, which can accumulate energy E1 or E3 (E=20 accumulates volume) parallel with the main register based on the limits programmed into tariff limits TL2 and TL3.

Example: EE=11 (Power tariff)

TA2 shows energy consumed...

...above the power limit TL2



EE=	TARIFF TYPE	FUNCTION	Country code 2xx	Country code 3xx	Country code 5xx	Country code 6xx	Country code 7xx	Country code 8xx	Country code 9xx
00	No active tariff	No function							
11	Power tariff	Energy is accumulated in TA2 and TA3 on the basis of the power limits entered in TL2 and TL3	•	•	•				
12	Flow tariff	Energy is accumulated in TA2 and TA3 on the basis of the flow limits entered in TL2 and TL3	•	•	•				
13	Cooling tariff	Energy is accumulated in TA2 and TA3 on the basis of the Δt limits entered in TL2 and TL3	•	•	•				
14	Flow temperature tariff	Energy is accumulated in TA2 and TA3 on the basis of the tF limits entered in TL2 and TL3	•	•	•				
15	Return temperature tariff	Energy is accumulated in TA2 and TA3 on the basis of the tR limits entered in TL2 and TL3	•	•	•				
19	Time controlled tariff	TL2=Start time for TA2 TL3=Start time for TA3	•	•	•				
20	Heat/cooling volume tariff (TL2 and TL3 are not used)	Volume (V1) is divided into TA2 for heat (T1>T2) and TA3 for cooling (T1<T2). (Recommended for heat/cooling applications)				•	•	•	
21	PQ-tariff	If P>TL2 energy is saved in TA2 and if Q>TL3 energy is saved in TA3	•	•	•				

See paragraph 7.9 for further details on the tariff registers.

### 3.6 >FF< Input A (VA), pulse division, >GG< Input B (VB), pulse division

MULTICAL® 402 has 2 extra pulse inputs, VA and VB, which are placed on the modules (see paragraph 11.3 for further details).

Modules	Type	402-	□	□□
Data + 2 pulse inputs (VA, VB)				10
M-Bus + 2 pulse inputs (VA, VB)				20
Wireless M-Bus, EU, 868 MHz, Mode T1 OMS (Ind. Key)				31
Wireless M-Bus, EU, 868 MHz, Mode C1 (Ind. Key) Alt. Reg. +VA, VB				35
Wireless M-Bus, EU, 868 MHz, Mode T1 (Common Key)				37
Wireless M-Bus, C1, Fixed Network, (Ind. Key)				38
Radio, EU, 434 MHz, Int.+Ext. Ant., NET0 + 2 pulse inputs (VA, VB)				42
Radio, EU, 434 MHz, Int.+Ext. Ant., NET1 + 2 pulse inputs (VA, VB)				44
Radio, SE, 444 MHz, Int. Ant., NET0 + 2 pulse inputs (VA, VB)				50
Radio, SE, 444 MHz, Int. Ant., NET1 + 2 pulse inputs (VA, VB)				52
Radio, SE, 444 MHz, Ext. Ant., NET0 + 2 pulse inputs (VA, VB)				54
Radio, SE, 444 MHz, Ext. Ant., NET1 + 2 pulse inputs (VA, VB)				56

Reconfiguration between pulse inputs and pulse outputs is not necessary with MULTICAL® 402. When a module with pulse inputs is mounted in MULTICAL® 402, the meter is automatically configured for pulse inputs.

The inputs are configured via the FF and GG codes as shown in the table below. In the absence of other information from the customer the inputs will be configured as FF=24 and GG=24. After delivery the FF and GG codes can be changed by means of the PC program METERTOOL (see paragraph 14).

Input A (65-66) Input B (67-68)		Precounter	l/imp	Position of decimal point
FF/GG	Max. Input 0.5 Hz			
01	50 m <sup>3</sup> /h	1	100	000000.0
02	25 m <sup>3</sup> /h	2	50	000000.0
03	12 m <sup>3</sup> /h	4	25	000000.0
04	5 m <sup>3</sup> /h	10	10	000000.0
05	2.5 m <sup>3</sup> /h	20	5.0	000000.0
06	1 m <sup>3</sup> /h	40	2.5	000000.0
07	0.5 m <sup>3</sup> /h	100	1.0	000000.0
24	5 m <sup>3</sup> /h	1	10	00000.00
25	2.5 m <sup>3</sup> /h	2	5.0	00000.00
26	1 m <sup>3</sup> /h	4	2.5	00000.00
27	0.5 m <sup>3</sup> /h	10	1.0	00000.00
40	500 m <sup>3</sup> /h	1	1000	0000000

Pulse durations: Min. 1 s. for Reed-switches and min. 30 ms. for electronic pulse outputs.

#### 3.6.1 Pulse inputs VA and VB

MULTICAL® 402 has two extra pulse inputs, VA and VB, for collection and remote totalization of pulses from e.g. mechanical water meters. The pulse inputs are physically placed on the modules, e.g. the "data/pulse input module", which can be mounted in the module base, but accumulation and data logging of values is carried out by the calculator.

Pulse inputs VA and VB function independently of the meter itself. Therefore their values are not included in any kind of energy calculation.

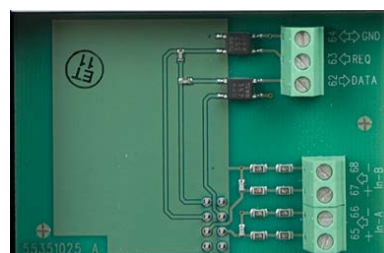

# MULTICAL® 402

The two pulse inputs are identically constructed and can be individually set up to receive pulses from water meters of max. 0.5 Hz.

Correct pulse value has been configured from the factory on the basis of order information, or is configured by means of METERTOOL. See paragraph 3.6 concerning configuration of VA (FF-codes) and VB (GG-codes).

MULTICAL® 402 registers the accumulated consumption of the meters connected to VA and VB and saves the counter values every month and every year on target date. In order to facilitate identification during data reading it is also possible to save the meter numbers of the two meters connected to VA and VB. Programming via METERTOOL or via the front keys.

The registration, which can both be read from the display (selecting a suitable DDD-code) and via data communication, includes the following as well as date indication of yearly and monthly data:

<b>Type of registration:</b>	<b>Counter value</b>	<b>Identification</b>	<b>Yearly data</b>	<b>Monthly data</b>
<b>VA</b> (accumulated register)	•			
Meter number VA		•		
Yearly data, up to latest 15 years			•	
Monthly data, up to latest 36 months				•
<b>VB</b> (accumulated register)	•			
Meter number VB		•		
Yearly data, up to latest 15 years			•	
Monthly data, up to latest 36 months				•

By means of METERTOOL counter values VA and VB can be preset to the values of the connected meters at the time of commissioning.

### 3.6.2 Display example, VA

In the example below VA has been configured to FF=24, which matches 10 litres/pulse and a max. flow of 5 m<sup>3</sup>/h. The meter connected to VA has meter no. 75420145 which has been saved in the internal memory of MULTICAL® 402 by means of METERTOOL.



Accumulated register of VA (Input A)



Meter no. of VA (max. 8 digits)



Yearly data, date of LOG1 (latest target date)



Yearly data, value of LOG1 (latest yearly reading)

This is the accumulated volume registered on 1 January 2010.

### 3.7 >PP< Output C and Output D

Pulse outputs for energy (CE) and volume (CV) are available on the following modules (see paragraph 11.1 for further information on connection):

	Type	402-	□	□□	
Data + 2 pulse outputs (CE, CV)					11
M-Bus + 2 pulse outputs (CE, CV)					21
Radio, EU, 434 MHz, Int.+Ext. Ant., NET0 + 2 pulse outputs (CE, CV)					43
Radio, EU, 434 MHz, Int.+Ext. Ant., NET1 + 2 pulse outputs (CE, CV)					45

Reconfiguration between pulse inputs and pulse outputs is not necessary with MULTICAL® 402. When a module with pulse outputs is mounted in MULTICAL® 402, the meter is automatically configured for pulse outputs. Pulse durations of 1 ms, 32 ms. or 0.1 s. are available when ordering. After delivery the pulse duration can be changed by means of the PC program METERTOOL (see paragraph 14)

Output C (CE) Terminal 16-17		Output D (CV) Terminal 18-19	
PP	Pulse duration		
94	1 ms.		
95	32 ms.	PP=95 is default on delivery	
96	0.1 s.	Pulse duration 0.1 s. reduces the battery lifetime. Please contact Kamstrup for further information	

### 3.8 Configuration during set up of country code

The two last characters of the type number, called the country code, are used to set up the language of the label text e.g. "meter in return", class 2 or 3, indication of approval and verification mark, as well as whether the meter is to be supplied with fast/slow integration speed, and if info codes are to be deleted automatically when the error disappears.

	Type	402-	□	□□	□	□□	□	□	□□
Country code									XX

Please contact Kamstrup for further details on available country codes. The available country codes appear from internal document 5514-169 on Kamstrup's Intranet.

#### 3.8.1 Integration time and reset type of info codes

Unless otherwise stated in the order the default configuration of MULTICAL® 402 will include integration (energy calculation) every 24 seconds as well as automatic reset of info codes when the error disappears.

24 s. integration (default)
4 s. integration

Info codes are reset automatically (default)
Info codes must be reset manually

### 3.8.2 Configuration data

During the production of MULTICAL® 402 values must be entered in the below-mentioned fields. Unless otherwise specified in the order, MULTICAL® 402 will be supplied with the below-mentioned "Automatic" and "Default" data.

	Automatic	To be stated when ordering	Default
Serial no. (S/N) as well as	60.000.000/2010	-	-
Customer No. Display No. 1 = 8 digits MSD Display No. 2 = 8 digits LSD	-	Up to 16 digits Limited to 11 digits in BOS dep. on PcBase compatibility	Customer number = S/N
Target date	-	MM=1-12 and DD=1-28	Dep. on country code
TL2	-	5 digits	0
TL3	-	5 digits	0
Average peak time	-	1...1440 min.	60 min.
$\theta_{hc}$ Heat/cooling switching	-	0.01...160.00°C *)	25.00°C
Date/time	YYYY.MM.DD/hh.mm.ss GMT+offset acc.to country code	GMT ± 12.0 hours (30 min. in leaps)	-

\*)  $\theta_{hc} = 180.00^\circ\text{C}$  switches off the function so that the meter can be used for "purchase/sales" of heat

S/N 60.000.000 to 62.499.999 have been reserved for MC402.

### 3.8.3 Customer label

In the top left corner of the type label an area of 15 x 38 mm has been reserved for customer labels (see paragraph 3.1), which can include e.g. the logo of a utility, a bar code etc. Unless otherwise specified in the order, MULTICAL® 402 will be supplied with customer label no. 2001-000, which includes the meter's customer number.

Please contact Kamstrup for the creation of new customer labels.

### 3.8.4 Other functions

Creating an order in BOS you can choose "fixed M-Bus addr" which means that all meters included in the order in question will be given the same M-Bus address.

### 3.8.5 Internal configuration survey

See instructions no. 5508-739 concerning update of programming and configuration.

## 4 Dimensioned sketches

### MULTICAL® 402

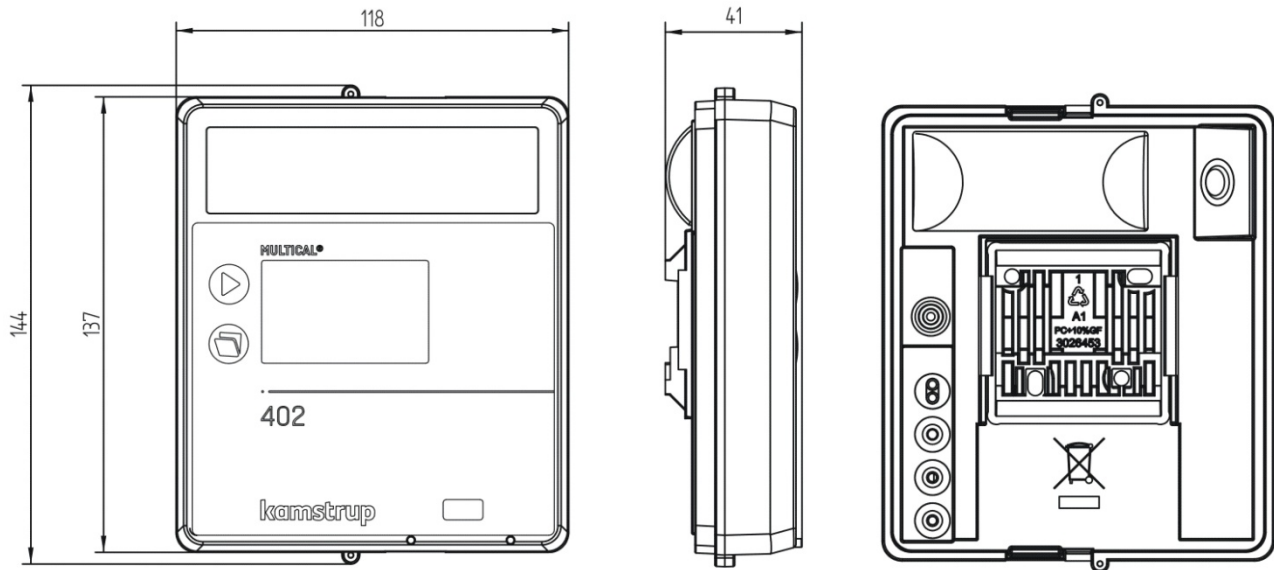

Figure 2: Mechanical dimensions of electronics unit

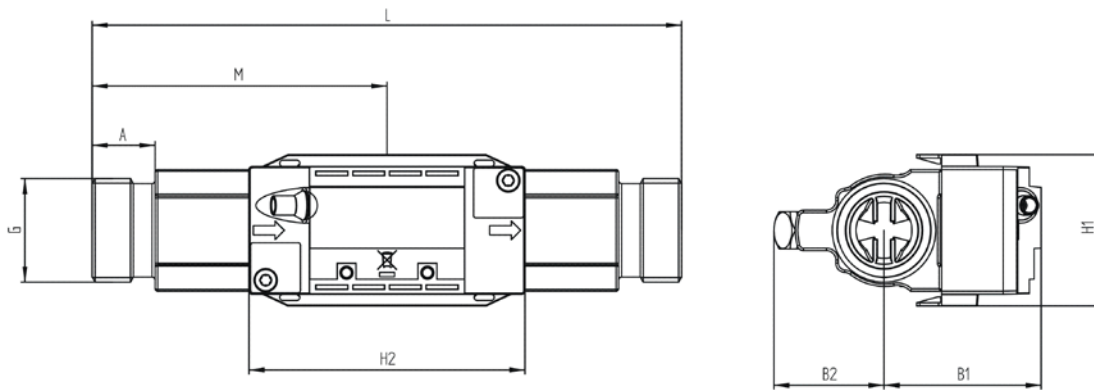

Figure 3: Flow sensor with G<sup>3/4</sup> and G1 thread connection

Thread	L	M	H2	A	B1	B2	H1	Approx. weight [kgs.]
G <sup>3/4</sup>	110	L/2	89	10.5	50.5	35	48.5	1.4
G1 (q <sub>p</sub> 1.5)	130	L/2	89	20.5	50.5	35	48.5	1.5
G1 (q <sub>p</sub> 3.0)	130	L/2	89	20.5	50.5	35	48.5	1.4
G <sup>3/4</sup>	165	L/2	89	20.5	50.5	35	48.5	1.8
G1 (q <sub>p</sub> 1.5)	190	L/2	89	20.5	50.5	35	48.5	2.0
G1 (q <sub>p</sub> 3.0)	190	L/2	89	20.5	50.5	35	48.5	1.9

Table 2: Weight is inclusive of 3 m short direct sensor set, but exclusive of packing

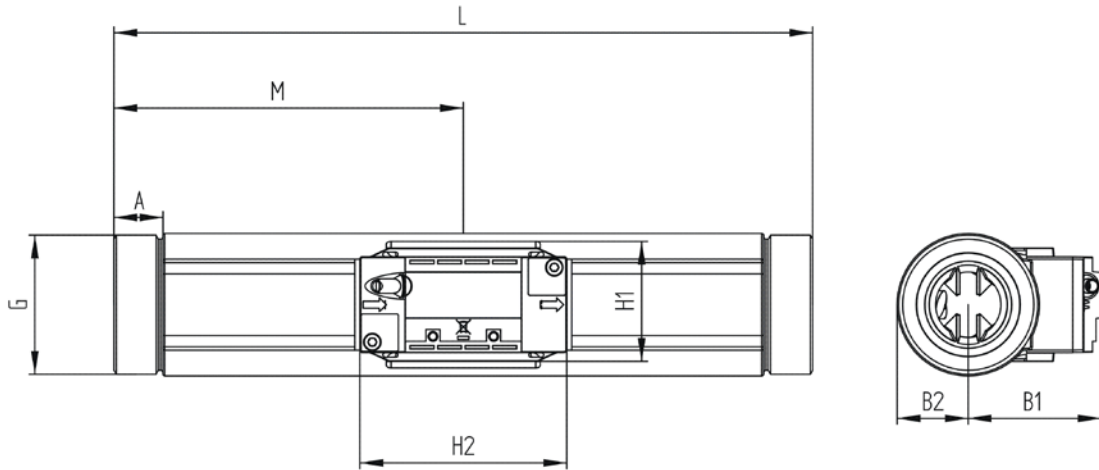

Figure 4: Flow sensor with G5/4 and G2 threaded connection

Thread	L	M	H2	A	B1	B2	H1	Approx. weight [kgs.]
G5/4	260	L/2	88.7	17	50.5	22	48.5	2.9
G2	300	L/2	88.7	21	50.5	31	48.5	5.1

Table 3: Weight is inclusive of 3 m sensor set, but exclusive of packing

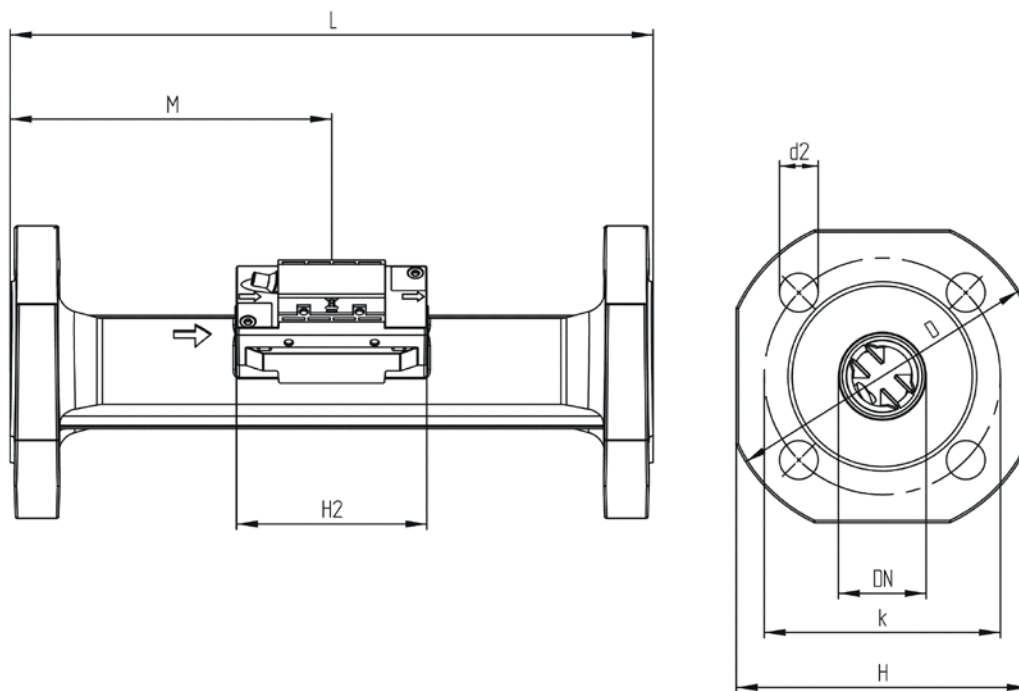

Figure 5: Flow sensor with DN25 to DN50 flange connection

Nom. diameter	L	M	H2	D	H	k	Bolts			Approx. weight [kgs.]
							Quantity	Thread	d2	
DN25	260	L/2	92.5	115	106	85	4	M12	14	5.6
DN40	300	L/2	92.5	150	136	110	4	M16	18	8.9
DN50	270	155	92.5	165	145	125	4	M16	18	10.7

Table 4: Weight is inclusive of 3 m sensor set, but exclusive of packing

## 5 Pressure loss

Pressure loss in a flow sensor is stated as max. pressure loss at  $q_p$ . According to EN 1434 max. pressure loss must not exceed 0.25 bar, unless the energy meter includes a flow controller or functions as pressure reducing equipment.

The pressure loss in a sensor increases with the square of the flow and can be stated as:

$$Q = kv \times \sqrt{\Delta p}$$

where:

Q = volume flow rate [m<sup>3</sup>/h]

kv = volume flow rate at 1 bar pressure loss [m<sup>3</sup>/h]

$\Delta p$  = pressure loss [bar]

Graphs	$q_p$ [m <sup>3</sup> /h]	Nom. diameter [mm]	kv	Q@0.25 bar [m <sup>3</sup> /h]
A	0.6 & 1.5	DN15...DN20	3	1.5
B	2.5 & 3.5 & 6	DN20 & DN25	13.5	6.8
C	10 & 15	DN40 & DN50	43	21.7

Table 5: Pressure loss table

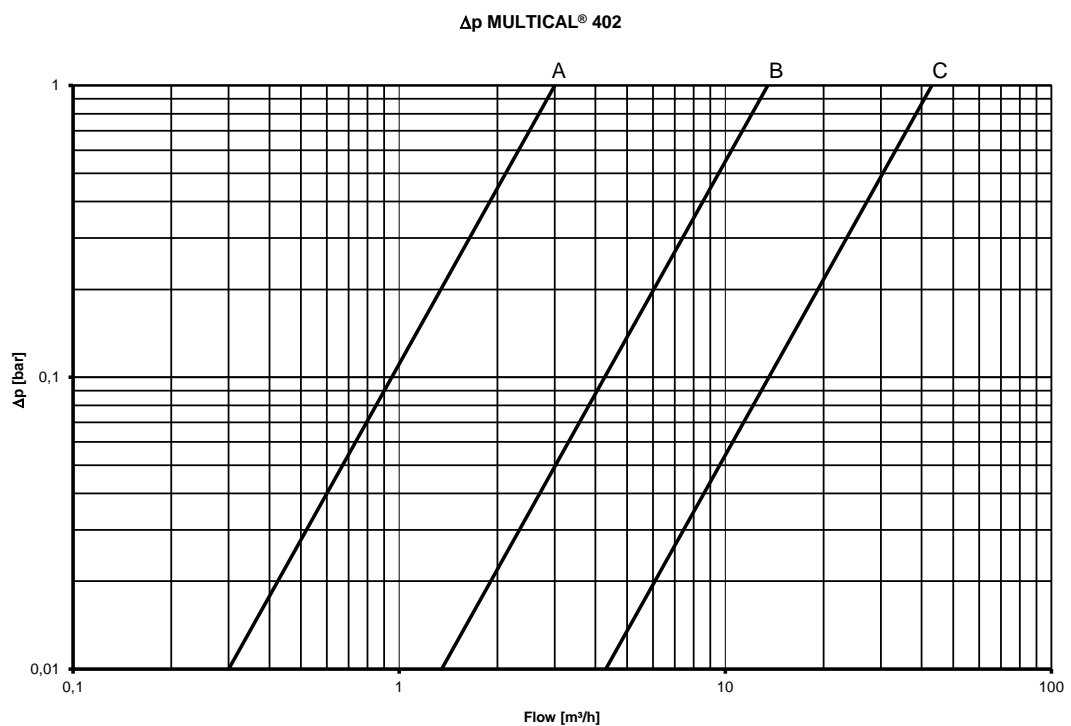

Diagram 2: Pressure loss graphs

## 6 Installation phase

### 6.1 Installation requirements

Prior to installation of MULTICAL® 402 the heating system should be flushed while a fitting piece replaces the meter. Remove the adhesive wafers from the meter's inlet and outlet and mount the flow sensor with glands/flanges. New fibre gaskets in original quality must be used.

If other glands than the original ones from Kamstrup A/S are used you must make sure that the threaded lengths of the glands do not prevent proper tightening of the sealing surface.

Correct placing of the flow sensor in flow or return appears from the type label on the front of the electronics unit and the flow direction is indicated by an arrow on the flow sensor.

In order to prevent cavitation the operating pressure at the flow sensor must be min. 1.5 bar at qp and min. 2.5 bar at qs. This applies to temperatures up to approx. 80°C. See paragraph 6.5 for further details on operating pressure.

When the installation has been completed, water flow can be turned on. The valve on the inlet side of the flow sensor must be opened first.

The flow sensor must not be exposed to lower pressure than the ambient pressure (vacuum).

#### Permissible operating conditions

Ambient temperature:	0...55°C (indoors). Max. 30°C for optimum battery lifetime
Medium temperature of heat meter:	15...130°C if the calculator is mounted on a wall 15...90°C for calculator mounted on flow sensor
Medium temperature of cooling meter:	2...50°C
Medium temperature of heat/cooling meter:	2...130°C if the calculator is mounted on a wall 2...90°C for calculator mounted on flow sensor
System pressure:	1.0 (1.5)...16 bar for threaded meters
(See paragraph 6.5)	1.0 (1.5)...25 bar for flange meters

#### Electrical installations

MULTICAL® 402 is available for both 24 VAC and 230 VAC mains supply. The mains connection consists of a two-wire cable without safety ground.

Use a strong connection cable with max. 7 mm outer diameter and ensure correct cable relief in the meter. Max. permitted fuse before the meter is 6A using 2 x 0.75 mm<sup>2</sup> connection cable.

National regulations for electric installations must be observed, including e.g. cable cross section used compared to the installation's fuse size (short circuit current).

Installation in Denmark is subject to announcement from the Danish Electricity Board concerning "Installations for mains supplied heat meters" for both 230 VAC direct supplied meters and 24 VAC meters powered via a safety transformer. See paragraph 10.9 for further information.

#### Service

When the meter has been mounted in the system neither welding nor freezing is allowed. Dismount the meter from the system and switch off the mains supply to the meter, if any, before starting the work.

In order to facilitate replacement of the meter, closing valves should be mounted on both sides of the meter.

Under normal operating conditions no pipe strainer is required in front of the meter.

## 6.2 Installation angle of MULTICAL® 402

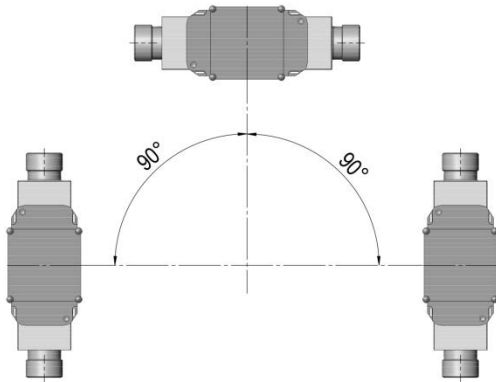

Figure 6

MULTICAL® 402 can be installed horizontally, vertically, or at an angle

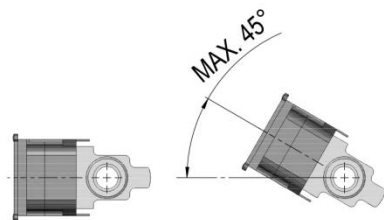

Figure 7

### Important!

MULTICAL® 402 can be turned max. 45° upwards and max. 90° downwards compared to the pipe axis.

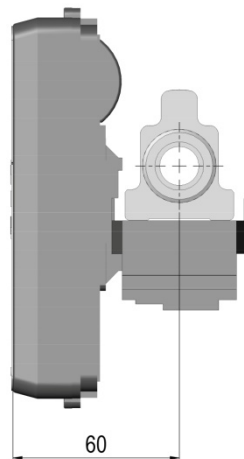

Figure 8

If minimum installation depth (G<sup>3/4</sup> and G1) is required, the flow sensor must be mounted with the electronics case pointing downwards and the calculator on the side

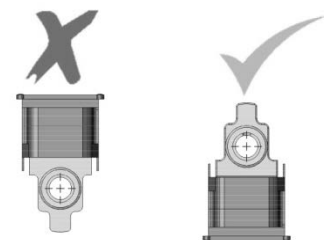

Figure 9

The electronics case must **not** point upwards

### 6.3 Straight inlet

MULTICAL® 402 neither requires straight inlet nor straight outlet to meet the Measuring Instruments Directive (MID) 2004/22/ EC, OIML R75:2002 and EN 1434:2009. A straight inlet section will only be necessary in case of heavy flow disturbances before the meter. We recommend to follow the guidelines of CEN CR 13582. Optimal position can be obtained if you take the below-mentioned installation methods into consideration:

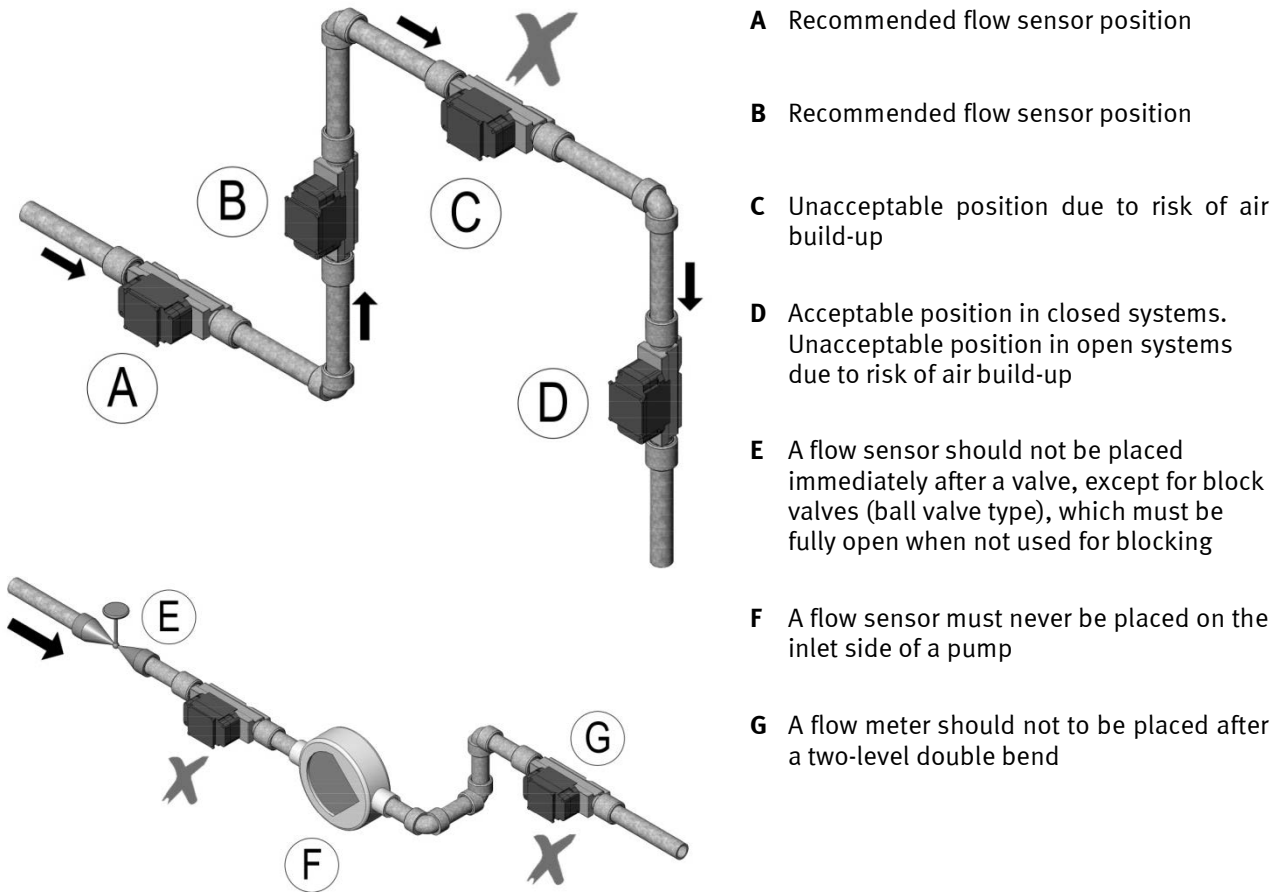

Figure 10

For general information concerning installation see CEN report *DS/CEN/CR 13582, Heat meter Installation. Instructions in selection, installation and use of heat meters.*

## 6.4 Installation examples

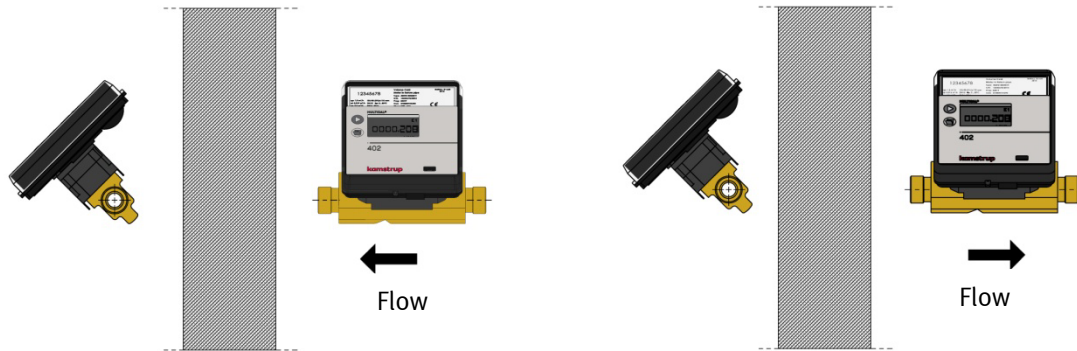

Figure 11: Threaded meter

Mounting of glands and short direct sensor mounted in MULTICAL<sup>®</sup>402 flow part (only G<sup>3</sup>/<sub>4</sub> (R<sup>1</sup>/<sub>2</sub>) and G1 (R<sup>3</sup>/<sub>4</sub>)).

The short direct sensor from Kamstrup can only be mounted in PN16 installations. The blind plug mounted in the MULTICAL<sup>®</sup> 402 flow part can be used in connection with both PN16 and PN25.

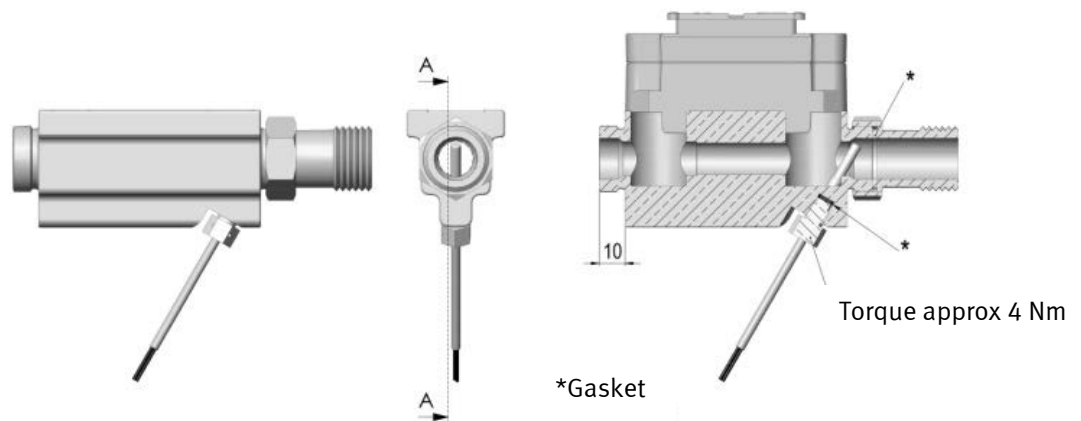

Figure 12

The flow meter can be used in both PN16 and PN25 and can be supplied marked either PN16 or PN25 as desired. Possibly supplied glands can only be used for PN16. For PN25 installations shall be used suitable PN25 glands.

**In connection with G<sup>3</sup>/<sub>4</sub>x110 mm and G1x110 mm it shall be checked that 10 mm thread run-out is sufficient.**

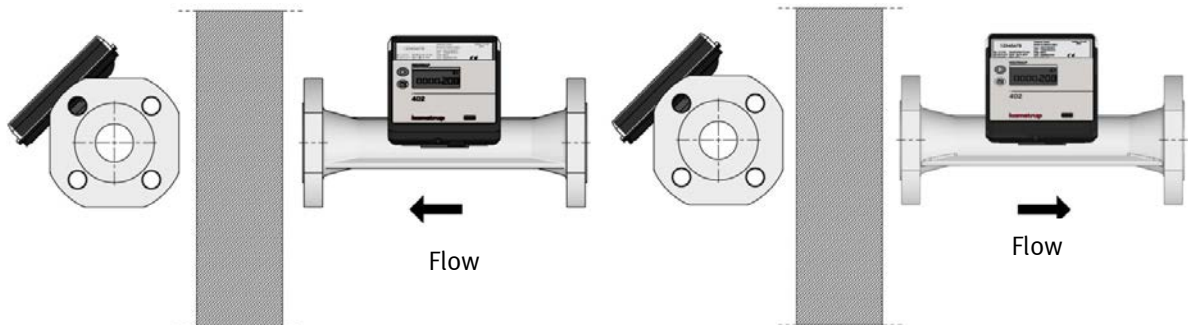

Figure 13: Flange meter

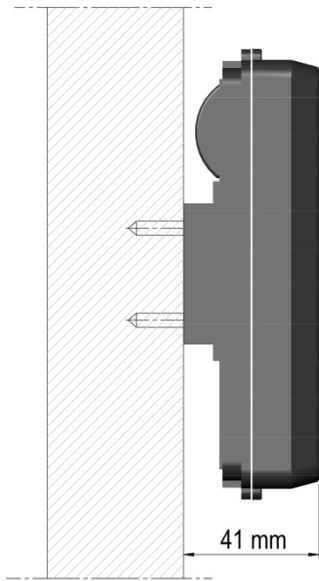

Figure 14: Wall mounted MULTICAL® 402

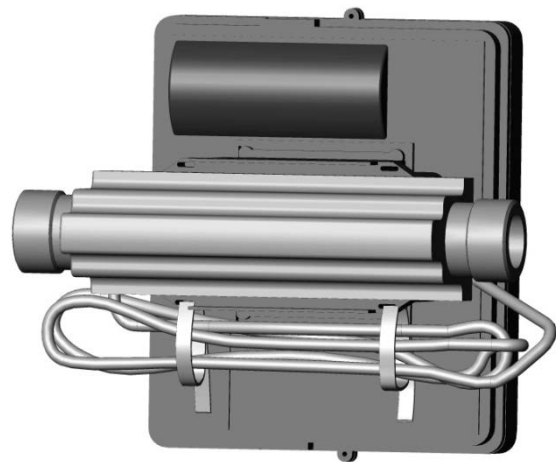

Figure 15: Fastening of cable

If the flow sensor is installed in a humid or condensing environment, the calculator must be mounted higher than the flow sensor.

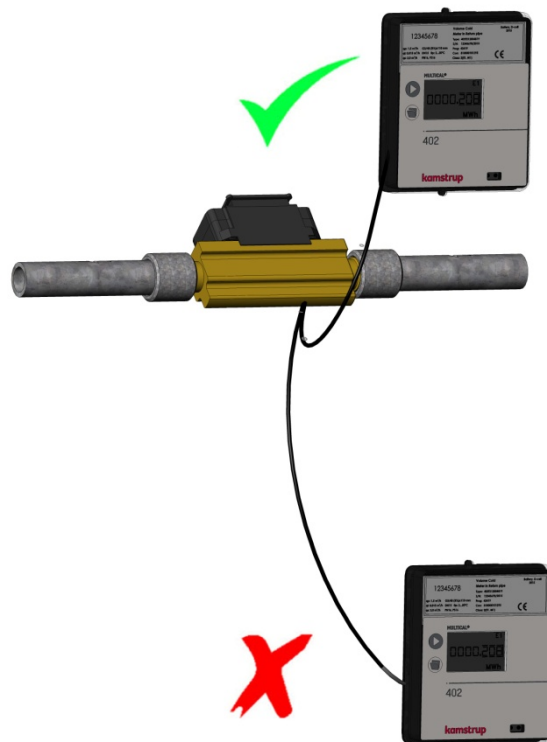

Figure 16

## 6.5 Operating pressure of MULTICAL® 402

In connection with installations it has proved practical to work with minimum the pressures mentioned below:

Nominal flow $q_p$ [m <sup>3</sup> /h]	Recommended back pressure [bar]	Max. flow $q_s$ [m <sup>3</sup> /h]	Recommended back pressure [bar]
0.6	1	1.2	2
1.5	1.5	3	2.5
2.5	1	5	2
3.5	1	7	2
6	1.5	12	2.5
10	1	20	2
15	1.5	30	2.5

Table 6

The purpose of recommended back pressure is to avoid measuring errors as a result of cavitation or air in the water.

It is not necessarily cavitation in the sensor itself, but also bubbles from cavitating pumps and regulating valves mounted before the sensor. It can take some time before such bubbles have been absorbed by the water.

Furthermore, water can include dissolved air. The amount of air which can be dissolved in water depends on pressure and temperature. This means that air bubbles can be formed due to pressure drop, e.g. caused by a velocity rise in a contraction or above the meter.

The risk of these factors affecting accuracy is reduced by maintaining a fair pressure in the installation.

In relation to above table, the steam pressure at current temperature must also be considered. Table 6 applies to temperatures up to approx. 80°C. Furthermore, it must be considered that the above-mentioned pressure is the back pressure at the sensor and that the pressure is lower under a contraction than before one (e.g. cones). This means that the pressure – when measured elsewhere - might be different from the pressure at the sensor.

This can be explained by combining the continuity equation and Bernoulli's equation. The total energy from the flow will be the same at any cross section. It can be reduced to:  $P + \frac{1}{2}\rho v^2 = \text{constant}$ .

When dimensioning the flow sensor you must take this into consideration, especially if the sensor is used within the scope of EN 1434 between  $q_p$  and  $q_s$ , and in case of heavy contractions of the pipe.

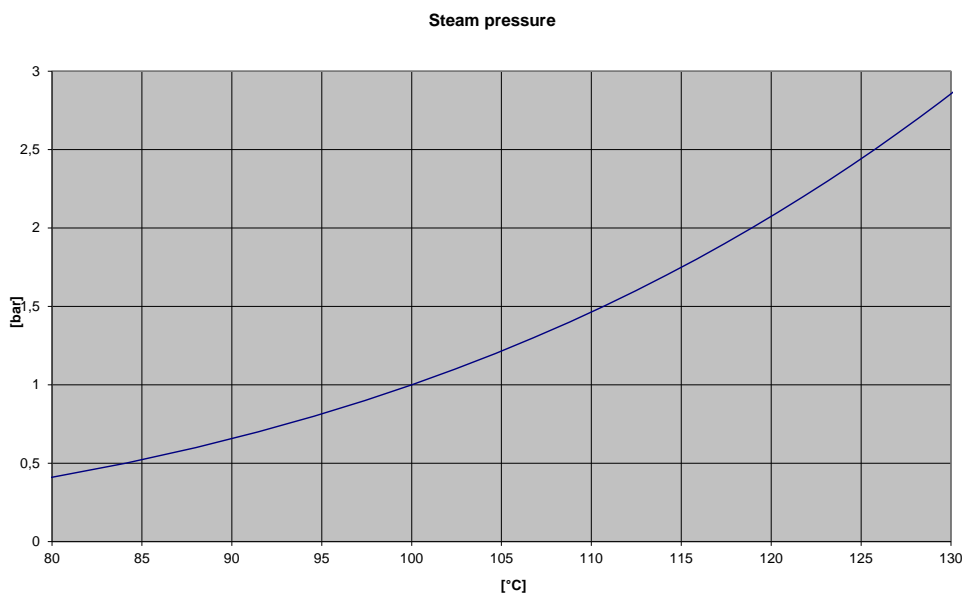

Diagram 3

### 6.6 Mounting in forward or return pipe

Prog. number

A  
□

MULTICAL® 402 is programmed for flow meter mounted in either forward or return pipe. The table below indicates installation conditions of:

- ◆ Heat meters
- ◆ Cooling meters
- ◆ Heat/cooling meters

**Flow sensor position:**

- Forward (at T1)	3
- Return (at T2)	4

Formula	k-factor	Prog.	Hot pipe	Cold pipe	Installation:
<b>Heat meter</b> $E1 = V1(T1 - T2)k$	k-factor for T1 in Inlet table	A=3 (Flow sensor in flow pipe)	V1 and T1	T2	
	k-factor for T2 in Outlet table	A=4 (Flow sensor in return pipe)	T1	V1 and T2	
<b>Cooling meter</b> $E3 = V1(T2 - T1)$	k-factor for T1 in Outlet table	A=3 (Flow sensor in flow pipe)	T2	V1 and T1	
	k-factor for T2 in Inlet table	A=4 (Flow sensor in return pipe)	V1 and T2	T1	

## 6.7 EMC conditions

MULTICAL® 402 has been designed and CE-marked according to EN 1434 Class A (corresponding to Electromagnetic environment: Class E1 of the Measuring Instruments Directive) and can thus be installed in both domestic and industrial environments.

All control cables must be drawn separately and not parallel to e.g. power cables or other cables with the risk of inducing electromagnetic interference. There must be a distance of min. 25 cm between signal cables and other installations.

## 6.8 Climatic conditions

MULTICAL® 402 has been designed for installation indoors in non-condensing environments with ambient temperatures from 5...55°C, however max. 30°C to ensure optimum battery lifetime.

Protection class IP54 of calculator and IP65 of flow sensor permits water sprinkling, but the meter does not stand submergence.

## 7 Calculator functions

### 7.1 Measuring sequences

MULTICAL® 402 uses time-based integration, which means that calculations of accumulated volume and energy are carried out at fixed time intervals independent of the current water flow. In normal mode the integration interval of MULTICAL® 402 is 24 s., whereas the interval is 4 s. in "fast mode".

**"Normal mode"**

In normal mode MULTICAL® 402 passes through an integration sequence of 24 sec. Through this sequence the water flow is measured at intervals of 3 s. Forward and return temperatures are measured in the middle of the sequence and at the end of the sequence energy and volume are calculated. All display readings are updated at intervals of 24 s. However, the current flow reading is updated at intervals of 12 s.

**"Fast mode"**

In fast mode MULTICAL® 402 passes through an integration sequence of 4 s. Through this sequence the water flow is measured at intervals of 1 s. Forward and return temperatures are measured in the middle of the sequence and at the end of the sequence energy and volume are calculated. All display readings are updated at intervals of 4 s.

Also see Meter cycle in paragraph 13.2.

### 7.2 Energy calculation

MULTICAL® 402 calculates energy on the basis of the formula stated in prEN 1434-1:2009, which uses the international temperature scale issued in 1990 (ITS-90) and the pressure definition of 16 bar.

In a simplified form the energy calculation can be expressed as: Energy = V x ΔΘ x k. The calculator always calculates energy in [Wh], and then converts the value to the selected measuring unit.

E [Wh] =	$V \times \Delta\Theta \times k \times 1000$
E [kWh] =	$E [Wh] / 1,000$
E [MWh] =	$E [Wh] / 1,000,000$
E [GJ] =	$E [Wh] / 277,780$
E [Gcal] =	$E [Wh] / 1,163,100$

**V** is the added (or simulated) water volume in m<sup>3</sup>

**ΔΘ** is the measured temperature difference. Heat energy (E1) ΔΘ = forward temperature – return temperature  
 Cooling energy (E1) ΔΘ = return temperature – forward temperature  
 Both in the display and during data reading each energy type is uniquely defined, e.g.

Heat energy:  $E1 = V1(T1-T2)k$



Cooling energy:  $E3 = V1(T2-T1)k$



**k** is the heat coefficient of water which is calculated on the basis of the formula stated in prEN 1434-1:2009 (identical with the energy formula of OIML R75-1:2002).

Kamstrup can supply an energy calculator for check measurement:

	Flow position	Return position	
Temperature:	70	60	°C
Pressure:	16	16	bar
Volume:	1	1	m3
<b>Calculations</b>			
Specific volume:	1,0220	1,0037	l/kg
Specific enthalpy:	81,7502	35,3333	Wh/kg
Heat coefficient:	1,1354	1,1561	kWh/m3/K
Energy:	45,4160	46,2459	kWh

Unit: kWh Resolution: 4 digits

### 7.3 Application types

MULTICAL® 402 operates with 4 different energy formulas, E1, E3, E8 and E9, which are all calculated parallel with each integration no matter how the meter is configured. E8 and E9 solely form the basis of the calculation of average temperatures in forward and return pipes, whereas E1 and E3 are used for heat and cooling measurement respectively.

#### 7.3.1 E1 and E3

Energy types E1 and E3 are described by application examples below.

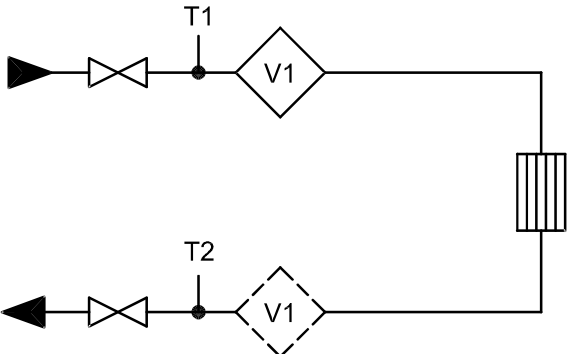
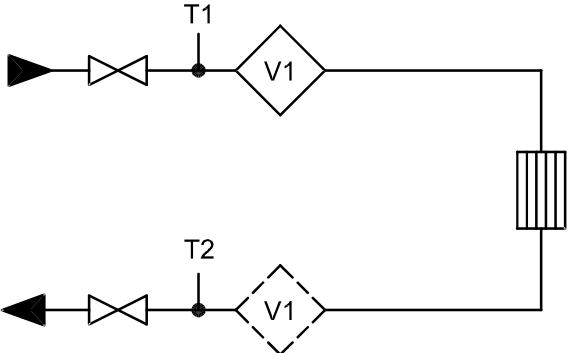
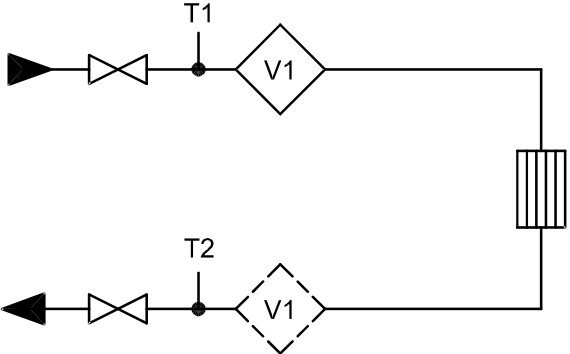
 <p style="text-align: center;"><b>402-Vxxxxxx2xx or 402-Wxxxxxx2xx</b></p>	<p><b>Application A</b></p> <p><b>Closed heating system with 1 flow sensor</b></p> <p>Heat energy: <math>E1 = V1(T1-T2)k_{T1:Forward \text{ or } T2:Return}</math></p> <p>Flow sensor V1 is placed in flow or return as selected during PROG.</p> <p>(Heat meter with MID marking and Pt100 or Pt500 sensor inputs)</p>
 <p style="text-align: center;"><b>402-Txxxxxx5xx</b></p>	<p><b>Application B</b></p> <p><b>Closed cooling system with 1 flow sensor</b></p> <p>Cooling energy: <math>E3 = V1(T2-T1)k_{T1:Forward \text{ or } T2:Return}</math></p> <p>Flow sensor V1 is placed in flow or return as selected during PROG.</p> <p>(Cooling meter with condensation protection and Pt500 sensor inputs)</p>
 <p style="text-align: center;"><b>402-Txxxxxx6xx</b></p>	<p><b>Application C</b></p> <p><b>Closed heat/cooling system with 1 flow sensor</b></p> <p>Heat energy: <math>E1 = V1(T1-T2)k_{T1:Forward \text{ or } T2:Return}</math></p> <p>Cooling energy: <math>E3 = V1(T2-T1)k_{T1:Forward \text{ or } T2:Return}</math></p> <p>Flow sensor V1 is placed in flow or return as selected during PROG.</p> <p>(Heat/cooling meter with condensation protection and Pt500 sensor inputs)</p>

**7.3.2 E8 and E9**

E8 and E9 are used as a basis for calculation of volume-based average temperatures in forward and return pipes respectively. With every volume enumeration (every 0.01 m<sup>3</sup> for qp 1.5 m<sup>3</sup>/h) the registers are accumulated by the product of m<sup>3</sup> x °C, which makes E8 and E9 a suitable basis for calculation of volume-based average temperatures.

E8 and E9 can be used for average calculation during any period of time as long as the volume register is read at the same time as E8 and E9.

**E8= m<sup>3</sup> x tF** E8 is accumulated by the product of m<sup>3</sup>x tF

**E9= m<sup>3</sup> x tR** E9 is accumulated by the product of m<sup>3</sup> x tR



**Resolution of E8 and E9**

E8 and E9 depend on the resolution of volume (m<sup>3</sup>)

Volume resolution	Resolution of E8 and E9
0000.001 m <sup>3</sup>	m <sup>3</sup> x °C x 10
00000.01 m <sup>3</sup>	m <sup>3</sup> x °C
000000.1 m <sup>3</sup>	m <sup>3</sup> x °C x 0,1
0000001 m <sup>3</sup>	m <sup>3</sup> x °C x 0,01

**Example 1:** Within a year a heating installation has consumed 250.00 m<sup>3</sup> district heating water and the average temperatures have been 95°C for flow and 45°C for return.  
E8 = 23750 and E9 = 11250.

**Example 2:** The average temperatures must be measured together with the yearly reading. Therefore, E8 and E9 are included in the yearly reading.

Date of reading	Volume	E8	Average of forward pipe	E9	Average of return pipe
2009.06.01	534.26 m <sup>3</sup>	48236		18654	
2008.06.01	236.87 m <sup>3</sup>	20123		7651	
Yearly consumption	297.39 m <sup>3</sup>	28113	28113/297.39 = <b>94.53°C</b>	11003	11003/297.39 = <b>36.99°C</b>

Table 7

### 7.4 Combined heat/cooling metering

MULTICAL® 402 is available as heat meter (Meter type 2xx), cooling meter (Meter type 5xx) or combined heat/cooling meter (Meter type 6xx).

<b>Meter type</b>	
Heat meter (MID)	2
Cooling meter	5
Heat/cooling meter	6
<b>Country code (language on label etc.)</b>	<b>XX</b>

If MULTICAL® 402 has been supplied as a combined heat/cooling meter (meter type 6xx), it measures heat energy (E1) at a positive temperature difference ( $T1 > T2$ ), whereas it measures cooling energy (E3) at a negative temperature difference ( $T2 > T1$ ). Temperature sensor T1 (with a red type sign) must be installed in the hydraulic forward pipe, whereas T2 (with a blue type sign) is installed in the return pipe.

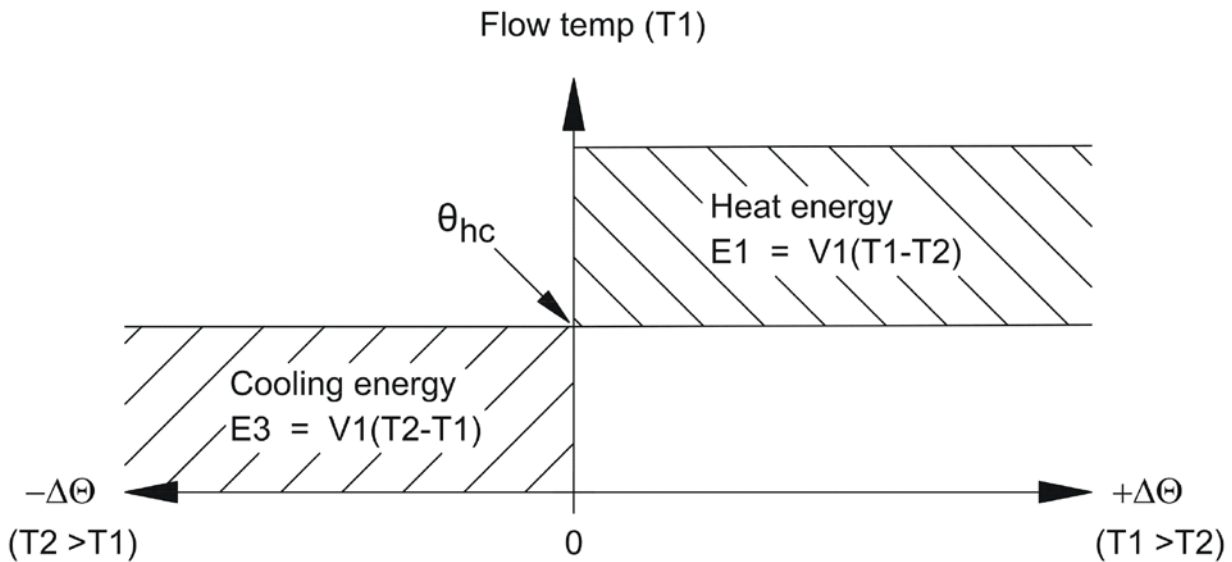

If the current T1 exceeds, or equals  $\theta_{hc}$  only heat energy can be measured. If the current T1 is lower than or equals  $\theta_{hc}$  only cooling energy can be measured.

$\theta_{hc}$  is the temperature point used to change between heat and cooling measurement.  $\theta_{hc}$  is configurable in temperature range 0.01...160.00°C.

In combined heat/cooling meters  $\theta_{hc}$  should correspond to the highest occurring forward temperature in connection with cooling, e.g. 25°C. If the meter is to be used for "purchase and sale of heat",  $\theta_{hc}$  is set at 180.00°C, which cancels the  $\theta_{hc}$  function.

If you want to switch the qhc function on or off compared to current condition, it is necessary to perform a total programming of the meter by means of METERTOOL.

The change between heat and cooling measurement involves no hysteresis ( $\Delta\theta_{hc} = 0.00K$ ).

$\theta_{hc}$  is configured by means of METERTOOL (see paragraph 14.2).

## 7.5 Min. and max. flow and power

MULTICAL® 402 registers minimum and maximum flow and power on both monthly and yearly basis. The registration can be read in full via data communication. Furthermore, a few monthly and yearly registers, depending on the selected DDD-code, can be read from the display.

The min. and max. registrations include the following flow and power values with indication of date:

Type of registration:	Max. data	Min. data	Yearly data	Monthly data
Max. this year (since latest target date)	•		•	
Max. yearly data, up to latest 15 years	•		•	
Min. this year (since latest target date)		•	•	
Min. yearly data, up to latest 15 years		•	•	
Max. this month (since latest target date)	•			•
Max. monthly data, up to latest 36 months	•			•
Min. this month (since latest target date)		•		•
Min. monthly data, up to latest 36 months		•		•

All max. and min. values are calculated as biggest and smallest average of a number of current flow or power measurements respectively. The average period used for all calculations can be selected in the interval 1...1440 min. in one minute leaps. (1,440 min. = 24 hours).

Average period and target date must be stated in the order or reconfigured by means of METERTOOL. Unless otherwise stated in the order, the default values - 60 min. for average period and target date applying to selected delivery code - are used.

At the end of a year and a month the max. and min. values are saved in the data logger, and the current max. and min. registers are "reset" according to the selected target date and the meter's internal clock and calendar.

"Reset" sets the max. value to zero and the min. value to e.g. 10000.0 kW at CCC=419.

Date of year-to-date max.



Value of year-to-date max.



Date of this month's min.



Value of this month's min.



## 7.6 Temperature measurement

Forward and return temperatures are measured by means of an accurately matched Pt500 or Pt100 sensor set. During each temperature measurement MULTICAL® 402 sends a measuring current through each sensor. The current is approx. 0.5 mA for Pt500 and approx. 2.5 mA for Pt100. Two measurements are carried out in order to suppress a possible low-frequency noise of 50 Hz (or 60 Hz), picked up via the sensor cables. Furthermore, current measurements are made on internal reference resistors in order to secure optimum measuring stability.

The display presents forward and return temperatures as well as the temperature difference in range 0.00°C to 165.00°C.

Forward or return temperatures under 0°C are displayed as 0.00°C, and temperatures above 165°C are displayed as 165.00°C. If one or both temperature sensors are outside measuring range, Info=008 (forward), Info=004 (return) or Info=012 (both sensors outside range) is set.

At negative temperature difference (forward < return) the temperature difference is displayed with a negative sign and cooling energy is calculated (provided that the meter has been configured for cooling metering).

### 7.6.1 Measuring current and power

Measuring current is only sent through the temperature sensors during the short duration of the temperature measurement. The effective power that is deposited in the sensor elements is thus very small, and its influence on self-heating of the temperature sensors is typically less than 1/1000 K.

	Pt100	Pt500
<b>Measuring current</b>	< 2.5 mA	< 0.5 mA
<b>Peak power</b>	< 1.0 mW	< 0.2 mW
<b>RMS influence</b> (fast mode)	< 10 µW	< 2 µW
<b>RMS influence</b> (normal mode)	< 2 µW	< 0.4 µW

### 7.6.2 Average temperatures

MULTICAL® 402 currently calculates the average temperatures of forward and return pipes (T1 and T2) in °C without decimals, and background calculations E8 and E9 (m³ x T1 and m³ x T2) are carried out with every volume enumeration (e.g. with every 0.01 m³ if the meter size is qp 1.5), whereas the display is updated every 24 hours. The average temperatures are thereby volume weighted and can, thus, be used directly for checking purposes.

Type of registration	Average	Yearly data	Monthly data
Year-to-date average (since latest target date)	•	•	
Month-to-date average (since latest target date)	•		•

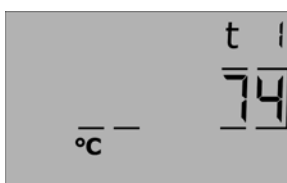

Year-to-date average of T1

(Current date with a stipulated line under year or month is shown immediately BEFORE this reading)

## 7.7 Display functions

MULTICAL® 402 is fitted with an easily readable LC-display comprising 8 digits, measuring units and an information field. Energy and volume readings use 7 digits with corresponding measuring units, whereas 8 digits are used to display e.g. the meter number.

Basically accumulated energy is displayed. Activating the pushbuttons, the display immediately switches to other readings. The display automatically returns to energy indication 4 minutes after the latest activation of the pushbuttons.

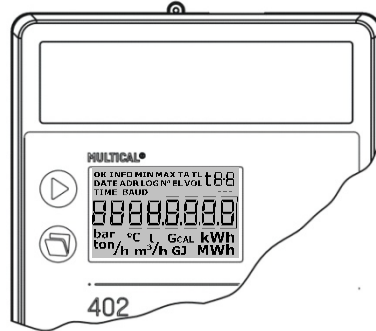

### 7.7.1 Primary and secondary readings

The upper pushbutton shifts between primary readings. Consumers normally use the first primary readings in connection with self-reading for billing purposes.

The lower pushbutton calls up secondary information on the selected primary reading.

Example: If the selected primary reading is "heat energy", the secondary readings can be yearly data and monthly data for heat energy.



Heat energy E1 in MWh



Yearly data, date of LOG1 (latest yearly reading)



Yearly data, value of LOG1 (latest yearly reading)



Monthly data, date of LOG1 (latest monthly reading)

**7.7.2 Display structure**

The below-mentioned diagram shows the display structure with up to 16 primary readings as well as a number of secondary readings under most primary readings. The number of secondary readings in connection with yearly and monthly data has been determined under the DDD-code. In the absence of other information in the order, readings will consist of 2 yearly data sets and 12 monthly data sets. The target date will be the standard date applying to the selected country code.

As the display is configured according to the customer's need (selection of DDD-code) the display will usually include much fewer readings than shown in the below diagram.

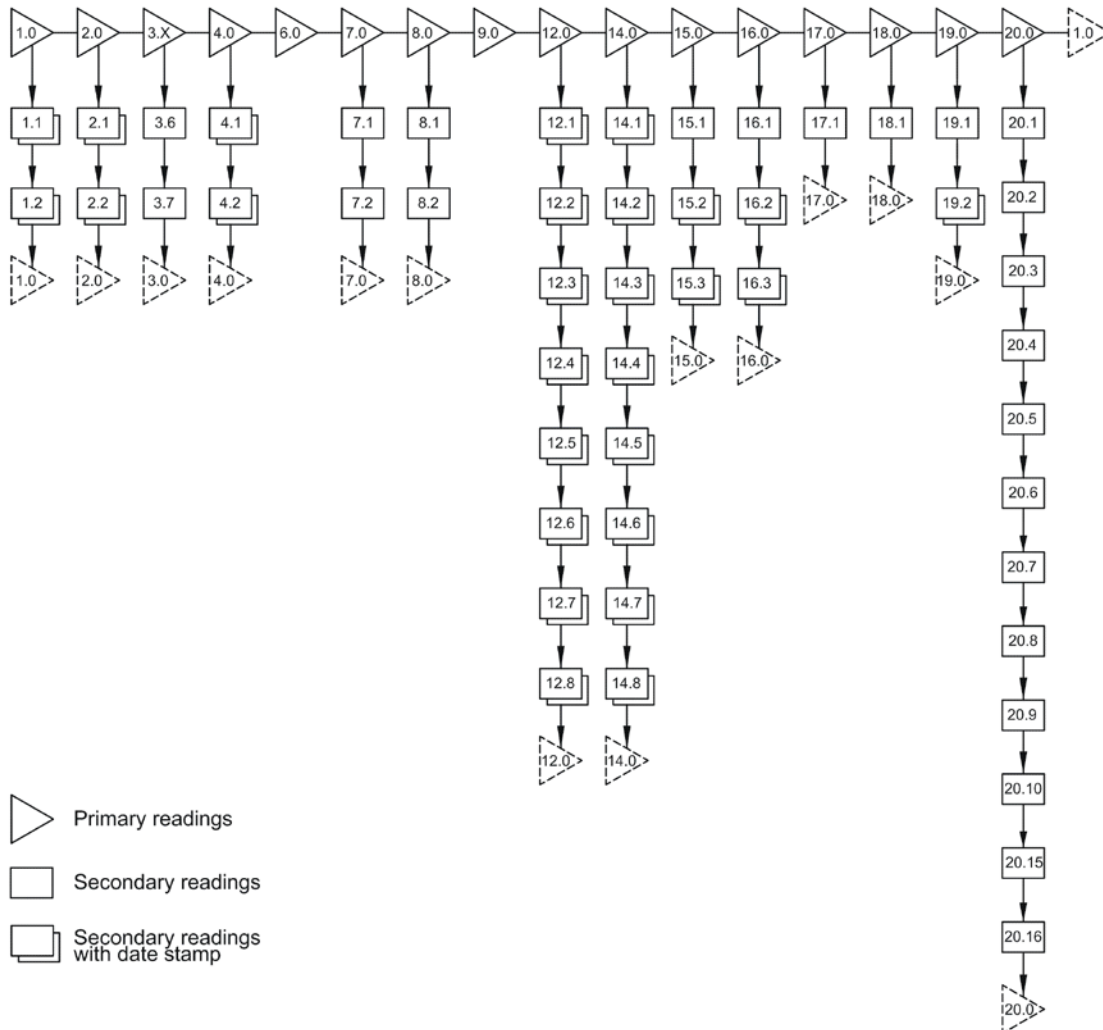





Figure 17

### 7.7.3 Display grouping

MULTICAL® 402 can be configured for many different applications, which creates the need for various display groups. The table below includes possible readings [●] of heat meters, cooling meters etc., readings supported by date stamp as well as the reading, to which the display automatically reverts 4 min. after the latest activation of the pushbuttons [1●]. (This paragraph is only used in connection with the creation of DDD-codes).

				Date Stamp	Heat meter DDD=2xx	Heat meter DDD=4xx	Cooling meter DDD=5xx	Heat/cooling DDD=6xx	Volume/Heat DDD=7xx	Volume/Cool DDD=8xx	Energy meter DDD=9xx
<b>1.0</b>	<b>Heat energy (E1)</b>				1●	1●		1●			1●
		1.1	Yearly data	●	●	●		●			●
		1.2	Monthly data	●	●	●		●			●
<b>2.0</b>	<b>Cooling energy (E3)</b>						1●	●			●
		2.1	Yearly data	●			●	●			●
		2.2	Monthly data	●			●	●			●
<b>2.PM</b>	<b>High-resolution energy (only in verification mode)</b>										
<b>3.X</b>	<b>Other energy types</b>										
		3.6	E8 (m3*tf)		●	●					●
		3.7	E9 (m3*tr)		●	●					●
<b>4.0</b>	<b>Volume</b>				●	●	●	●	1●	1●	●
		4.1	Yearly data	●	●	●	●	●	●	●	●
		4.2	Monthly data	●	●	●	●	●	●	●	●
<b>4.PM</b>	<b>Volume - High-resolution (only in verification mode)</b>										
<b>6.0</b>	<b>Hour counter</b>				●	●	●	●	●	●	●
<b>7.0</b>	<b>T1 (Flow)</b>				●	●	●	●	●	●	●
		7.1	Year-to-date average		●	●	●	●	●	●	●
		7.2	Month-to-date average		●	●	●	●	●	●	●
<b>8.0</b>	<b>T2 (Return)</b>				●	●	●	●	●	●	●
		8.1	Year-to-date average		●	●	●	●	●	●	●
		8.2	Month-to-date average		●	●	●	●	●	●	●
<b>9.0</b>	<b>T1-T2 (Δt) - = cooling</b>				●	●	●	●	●	●	●
<b>12.0</b>	<b>Flow</b>				●	●	●	●	●	●	●
		12.1	This year's max.	●	●	●	●	●	●	●	●
		12.2	Max. yearly data	●	●	●	●	●	●	●	●
		12.3	This year's min.	●	●	●	●	●	●	●	●
		12.4	Min. yearly data	●	●	●	●	●	●	●	●
		12.5	This month's max.	●	●	●	●	●	●	●	●
		12.6	Max. monthly data	●	●	●	●	●	●	●	●
		12.7	This month's min.	●	●	●	●	●	●	●	●
		12.8	Min. monthly data	●	●	●	●	●	●	●	●
<b>14.0</b>	<b>Power (V1)</b>				●	●	●	●	●	●	●
		14.1	This year's max.	●	●	●	●	●	●	●	●
		14.2	Max. yearly data	●	●	●	●	●	●	●	●
		14.3	This year's min.	●	●	●	●	●	●	●	●
		14.4	Min. yearly data	●	●	●	●	●	●	●	●
		14.5	This month's max.	●	●	●	●	●	●	●	●
		14.6	Max. monthly data	●	●	●	●	●	●	●	●
		14.7	This month's min.	●	●	●	●	●	●	●	●
		14.8	Min. monthly data	●	●	●	●	●	●	●	●

				Date Stamp	Heat meter DDD=2xx	Heat meter DDD=4xx	Cooling meter DDD=5xx	Heat/cooling DDD=6xx	Volume/Heat DDD=7xx	Volume/Cool DDD=8xx	Energy meter DDD=9xx
											
<b>15.0</b>	<b>VA (Input A)</b>				•	•	•	•	•	•	•
		15.1	Meter No. VA		•	•	•	•	•	•	•
		15.2	Yearly data	•	•	•	•	•	•	•	•
		15.3	Monthly data	•	•	•	•	•	•	•	•
<b>16.0</b>	<b>VB (Input B)</b>				•	•	•	•	•	•	•
		16.1	Meter No. VB		•	•	•	•	•	•	•
		16.2	Yearly data	•	•	•	•	•	•	•	•
		16.3	Monthly data	•	•	•	•	•	•	•	•
<b>17.0</b>	<b>TA2</b>				•	•		•	•	•	•
		17.1	TL2		•	•		•	•	•	•
<b>18.0</b>	<b>TA3</b>				•	•		•	•	•	•
		18.1	TL3		•	•		•	•	•	•
<b>19.0</b>	<b>Info Code</b>				•	•	•	•	•	•	•
		19.1	Info event counter		•	•	•	•	•	•	•
		19.2	Info logger (36 latest events)	•	•	•	•	•	•	•	•
<b>20.0</b>	<b>Customer No. (N° 1+2)</b>				•	•	•	•	•	•	•
		20.1	Date		•	•	•	•	•	•	•
		20.2	Hour		•	•	•	•	•	•	•
		20.3	Target date		•	•	•	•	•	•	•
		20.4	Serial no. (N° 3)		•	•	•	•	•	•	•
		20.5	Prog. (A-B-CCC-CCC) (N° 4)		•	•	•	•	•	•	•
		20.6	Config 1 (DDD-EE) (N° 5)		•	•	•	•	•	•	•
		20.7	Config 2 (FF-GG-M-N) (N° 6)		•	•	•	•	•	•	•
		20.8	Software edition (N° 10)		•	•	•	•	•	•	•
		20.9	Software check sum (N° 11)		•	•	•	•	•	•	•
		20.10	Segment test		•	•	•	•	•	•	•
		20.15	M-Bus primary address (N° 31)		•	•	•	•	•	•	•
		20.16	M-Bus second. address (N° 32)		•	•	•	•	•	•	•



Example of reading of PROG number.

A total overview of existing display codes (DDD) is described in a separate document. Please contact Kamstrup for further details.

## 7.8 Info codes

MULTICAL® 402 constantly monitors a number of important functions. If a serious error occurs in measuring system or installation, a flashing “info” will appear in the display. The “INFO” field keeps flashing as long as the error exists no matter which reading you choose. The “INFO” field automatically disappears when the reason for the error has been removed. (However, configuration for “Manual reset of info codes” is possible via country code creation. If “Manual reset of info codes”, has been chosen, info codes will remain in the display until they have been manually reset).

### 7.8.1 Info code types

Info code	Description	Response time
0	No irregularities	-
1	Supply voltage has been interrupted	-
8	Temperature sensor T1 outside measuring range	< 30 sec.
4	Temperature sensor T2 outside measuring range	< 30 sec.
4096	Flow sensor with weak signal or air	< 30 sec.
16384	Flow sensor with wrong flow direction	< 30 sec.

If more than one info code appear at a time, the sum of info codes is displayed. If e.g. both temperature sensors are outside measuring range, info code 12 (info code 4+8) is displayed.

### 7.8.2 Examples of info codes in the display

#### Example 1



#### Flashing “iNFO”

If the information code exceeds 000, a flashing “INFO” will appear in the information field.

#### Example 2



#### Current information code

Activating the upper (primary) pushbutton several times, the current information code is displayed.

#### Example 3

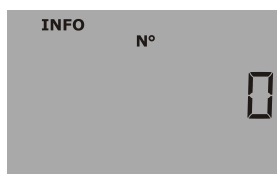

#### Info event counter

- shows how many times the information code has been changed.

#### Example 4



#### Info logger

If you press the lower pushbutton once more, the data logger for information code is displayed.

First the date of the latest change is shown...

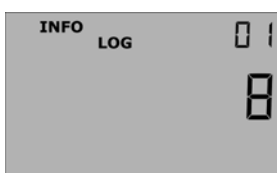

...next the information code set on this date is displayed. In this case there has been a sensor error in temperature sensor T1 on 4 January 2010.

The data logger saves the latest 50 changes. The latest 36 changes can be displayed, and the rest can be read by means of METERTOOL.

Furthermore, the info code is saved in daily, monthly and yearly logger for diagnostic purposes.

### 7.8.3 Info event counter

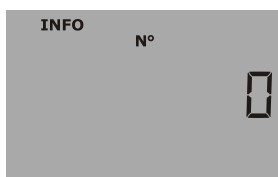

#### Info event counter

Enumeration each time the info code is changed (the info code is added to the info-event counter and data logged when it has existed for an hour).

The info event counter of a new meter will be 0 as “transport mode” prevents counting during transportation.

Info code	”info” in display	Registration in info, daily, monthly or yearly logger	Enumeration of Info event
<b>00001</b>	No	Yes	With each ”Power-On-Reset”
<b>00004, 00008</b>	Yes	Yes	When Info 4 or 8 is set or removed. Max. 1 per temperature measurement
<b>4096, 16384</b>	Yes	Yes	When Info is set and when Info is deleted. Max. one per code, per 24 hrs.

### 7.8.4 Transport mode

When the meter leaves the factory it is in transport mode, i.e. the info codes are active in the display only, not in the data logger. This prevents ”infoevent” from counting during transportation and irrelevant data from being saved in the info logger. The first time the meter accumulates the volume register after the installation, the info code automatically becomes active.

## 7.9 Tariff functions

MULTICAL® 402 has 2 extra registers TA2 and TA3, which can accumulate heat energy or cooling energy (EE=20 accumulates volume) parallel with the main register based on entered tariff conditions. Irrespective of the selected tariff type the tariff registers are called TA2 and TA3 in the display.

The main register is always accumulated as it is considered the legal billing register no matter the selected tariff function. Tariff conditions TL2 and TL3 are monitored at each integration. If the tariff conditions are fulfilled, consumed heat energy is accumulated in either TA2 or TA3 parallel with the main register.

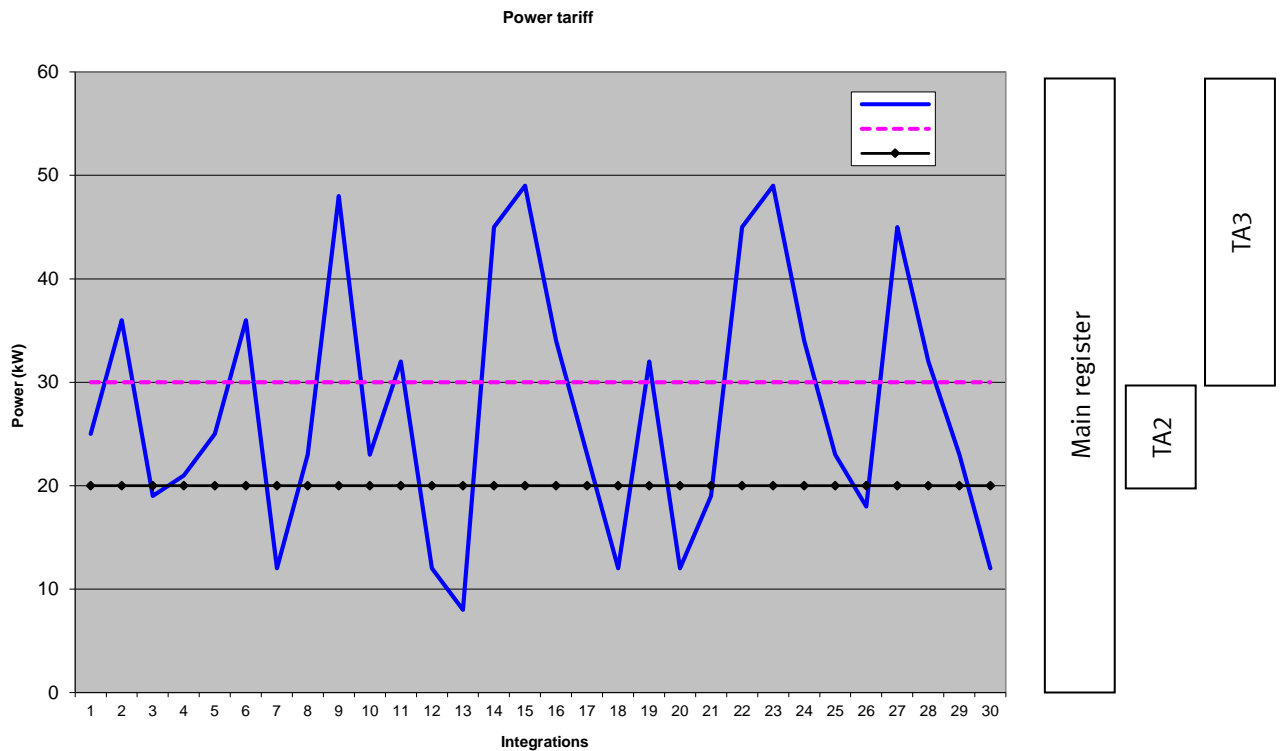

2 tariff conditions TL2 and TL3, which are always used in the same tariff type, are connected to each tariff function. Therefore, it is not possible to “mix” 2 tariff types.

Example: EE=11 (Power tariff)

TA2 shows energy consumed...



...above power limit TL2 (but below TL3)



**7.9.1 Tariff types**

The table below lists the tariff types for which MULTICAL® 402 can be configured:

EE=	TARIFF TYPE	FUNCTION
00	No active tariff	No function
11	Power tariff	Energy is accumulated in TA2 and TA3 on the basis of the power limits entered in TL2 and TL3
12	Flow tariff	Energy is accumulated in TA2 and TA3 on the basis of the flow limits entered in TL2 and TL3
13	T1-T2 tariff	Energy is accumulated in TA2 and TA3 on the basis of the $\Delta t$ -limits entered in TL2 and TL3
14	Flow temperature tariff	Energy is accumulated in TA2 and TA3 on the basis of the tF-limits entered in TL2 and TL3
15	Return temperature tariff	Energy is accumulated in TA2 and TA3 on the basis of the tR-limits entered in TL2 and TL3
19	Time controlled tariff	TL2=Start time for TA2 TL3=Start time for TA3
20	Heat/cooling volume tariff (TL2 and TL3 are not used)	Volume (V1) is divided into TA2 for heat (T1>T2) and TA3 for cooling (T1<T2) provided that T1 is below T1 limit
21	PQ-tariff	Energy is saved in TA2 if P>TL2 and energy is saved in TA3 if Q>TL3

**EE=00 No active tariff**

If no tariff function is required, you select the setup EE=00.

The tariff function can, however, be activated at a later stage through reconfiguration via METERTOOL for MULTICAL® 402. See section 14 METERTOOL.

**EE=11 Power controlled tariff**

If the current power exceeds TL2 but is lower than or equal to TL3, the energy is counted in TA2 parallel to the main register. If the current power exceeds TL3, the energy is counted in TA3 parallel to the main register.

$P \leq TL2$	Accumulation in main register only	$TL3 > TL2$
$TL3 \geq P > TL2$	Accumulation in TA2 and main register	
$P > TL3$	Accumulation in TA3 and main register	

Setting up data TL3 must include a higher value than TL2. The power controlled tariff is e.g. used as a basis for the individual heat consumer’s connection fee. Furthermore, this tariff type can provide valuable statistical data if the heating station considers new construction activities.

**EE=12 Flow controlled tariff**

If the current water flow exceeds TL2 but is lower than or equal to TL3, the energy is counted in TA2 parallel to the main register. If the current water flow exceeds TL3, the energy is counted in TA3 parallel to the main register. Setting up data TL3 must include a higher value than TL2.

$q \leq TL2$	Accumulation in main register only	$TL3 > TL2$
$TL3 \geq P > TL2$	Accumulation in TA2 and main register	
$q > TL3$	Accumulation in TA3 and main register	

The flow controlled tariff is e.g. used as a basis for the individual heat consumer’s connection fee. Furthermore, this tariff type can provide valuable statistical data if the heating station considers new construction activities.

When either power or flow tariff is used you obtain an overview of the total consumption compared to the part of the consumption used above tariff limit.

**EE=13 T1-T2 tariff ( $\Delta t$ )**

If the current T1-T2 ( $\Delta t$ ) is lower than TL2 but exceeds TL3, the energy is counted in TA2 parallel to the main register. If current cooling falls below or is equal to TL3, the energy is counted in TA3 parallel with the main register.

$\Delta t \geq TL2$	Accumulation in main register only	TL3 < TL2
$TL3 < \Delta t < TL2$	Accumulation in TA2 and main register	
$\Delta t \leq TL3$	Accumulation in TA3 and main register	

Setting up tariff limits TL3 must always include a higher value than TL2.

The T1-T2 tariff can be used as a basis for weighted user charge. Low  $\Delta t$  (small difference between forward and return temperatures) is uneconomical for the heat supplier.

**E=14 Forward temperature tariff**

If the current forward temperature (T1) exceeds TL2 but is lower than or equal to TL3, the energy is counted in TA2 parallel to the main register. If the current forward temperature exceeds TL3, the energy is counted in TA3 parallel to the main register.

$T1 \leq TL2$	Accumulation in main register only	TL3 > TL2
$TL3 \geq T1 > TL2$	Accumulation in TA2 and main register	
$T1 > TL3$	Accumulation in TA3 and main register	

Setting up data TL3 must always include a higher value than TL2.

The forward temperature tariff can be used as a basis for billing consumers who are guaranteed a certain forward temperature. If the “guaranteed” minimum temperature is entered as TL3, the payable consumption is accumulated in TA3.

**EE=15 Return temperature tariff**

If the current return temperature (T2) exceeds TL2 but is lower than or equal to TL3, the energy is counted in TA2 parallel to the main register. If the current return temperature exceeds TL3, the energy is counted in TA3 parallel to the main register.

$T2 \leq TL2$	Accumulation in main register only	TL3 > TL2
$TL3 \geq T2 > TL2$	Accumulation in TA2 and main register	
$T2 > TL3$	Accumulation in TA3 and main register	

Setting up data TL3 must always include a higher value than TL2.

The return temperature tariff can be used as a basis for weighted user charge. A high return temperature indicates insufficient heat utilization which is uneconomical for the heat supplier.

# MULTICAL® 402

## EE=19 Time-controlled tariff

The time-controlled tariff is used for time division of the energy consumption. If TL2 = 08:00 and TL3 = 16:00, the daily consumption from 8 a.m. to 4 p.m. is accumulated in TA2, whereas the consumption during evening and night from 4:01 p.m. to 7:59 a.m. will be accumulated in TA3.

TL2 must include a lower hour value than TL3.

$TL\ 3 \geq \text{Clock} \geq TL2$	Accumulation in TA2 and main register	TL3 > TL2
$TL\ 2 > \text{Clock} > TL3$	Accumulation in TA3 and main register	

The time tariff is suitable for billing in housing areas close to industrial areas with large district heating consumption, as well as for billing industrial customers.

## EE=20 Heat/cooling volume tariff

Heat/cooling volume tariff is used for division of volume into heat and cooling consumption. TA2 accumulates the volume consumed together with E1 (heat energy) and TA3 accumulates the volume consumed together with E3 (cooling energy).

$T1 \geq T2$ and $T1 \geq \theta_{hc}$	Volume is accumulated in TA2 and V1	TL2 and TL3 are not used
$T2 > T1$ and $T1 \leq \theta_{hc}$	Volume is accumulated in TA3 and V1	

For combined heat/cooling metering the total volume is accumulated in the register V1, whereas heat energy is accumulated in E1 and cooling energy in E3. The heat/cooling tariff is used for dividing the consumed volume into heat and cooling volume.

EE=20 should always to be selected together with heat/cooling meters type 402-xxxxxx-6xx.

## E=21 PQ tariff

The PQ tariff is a combined power and flow tariff. TA2 functions as power tariff and TA3 functions as flow tariff.

$P \leq TL2$ and $q \leq TL3$	Accumulation in main register only	TL2 = power limit (P) TL3 = flow limit (q)
$P > TL2$	Accumulation in TA2 and main register	
$q > TL3$	Accumulation in TA3 and main register	
$P > TL2$ and $q > TL3$	Accumulation in TA2, TA3 and main register	

The PQ tariff can e.g. be used for customers who pay a fixed charge based on max. power and max. flow.

## 7.10 Data loggers

MULTICAL® 402 has a permanent memory (EEPROM), in which the values of various data loggers are saved. The meter includes the following data loggers:

Data logging interval	Data logging depth	Logged value
Yearly logger	15 years	Counter register •
Monthly logger	36 months	Counter register •
Daily logger	460 days	Consumption (increase)/day ♦
Info logger	50 Events (36 events can be displayed)	Info code and date

The loggers are static ones and the register types can therefore not be changed, the same applies to the logging intervals. When the last record has been written into the EEPROM the oldest one will be overwritten.

### 7.10.1 Yearly, monthly, daily loggers

The following registers are logged every year and every month on target date as counter values. Furthermore, the day's increase is logged at midnight.

Register type	Description	Yearly logger	Monthly logger	Daily logger
Date (YY.MM.DD)	Logging time, year, month and day	•	•	♦
E1	$E1=V1(T1-T2)$ Heat energy	•	•	♦
E3	$E3=V1(T2-T1)$ Cooling energy	•	•	♦
E8	$E8=m^3 \times T1$ (flow)	•	•	♦
E9	$E9=m^3 \times T2$ (return)	•	•	♦
TA2	Tariff register 2	•	•	-
TA3	Tariff register 3	•	•	-
V1	Volume register for Volume 1	•	•	♦
VA	Extra water meter connected to Input A	•	•	♦
VB	Extra water meter connected to Input B	•	•	♦
INFO	Information code	•	•	♦
DATE FOR MAX. FLOW V1	Date stamp for max. flow during period	•	•	-
MAX. FLOW V1	Value of max. flow during period	•	•	-
DATE FOR MIN. FLOW V1	Date stamp for min. flow during period	•	•	-
MIN. FLOW V1	Value of min. flow during period	•	•	-
DATE FOR MAX. POWER V1	Date stamp for max. power during period	•	•	-
MAX. POWER V1	Value of max. power during period	•	•	-
DATE FOR MIN. POWER V1	Date stamp for min. flow during period	•	•	-
MIN. POWER V1	Value for min. power during period	•	•	-
T1avg	Time average of T1	-	-	♦
T2avg	Time average of T2	-	-	♦



### 7.10.2 Info logger

Every time the information code has been changed for minimum one hour, date and info code are logged. Thus, it is possible to data read the latest 50 changes of the information code as well as the date the change was made.

Register type	Description
Date (YY.MM.DD)	Logging time, year, month and day
info	Information code on above date

When the info logger is read from the display, the latest 36 changes including dates can be read too. All 50 changes can be read by means of the PC program METERTOOL (paragraph 14).

## 7.11 Setup via front keys

The meter is fitted with two keys – a main key  and a subkey . It is possible to adjust date and time or change other registers manually by means of the keys on the calculator's front

### 7.11.1 Activate setup menu

The setup menu is activated as follows:

- 1) Select the reading you want to change in the display
- 2) Disconnect the meter supply by removing the supply plug from the meter.
- 3) Wait until the reading disappears from the meter, i.e. until the display is totally blank (up to 2.5 min.). Do not activate any keys
- 4) Keep pressing the main key while connecting the supply (plugging the supply plug into the meter) until no more lines are shown in the display
- 5) The setup menu is now active

Having activated the setup menu the register you want to change is displayed and the rightmost digit in the display flashes:



If you try to activate the setup menu of a register which is not supported by setup, the meter will start in the usual way beginning with the legal reading without activating the setup menu.

### 7.11.2 Set up reading value

Having activated the setup menu the current value of the reading to be changed will be displayed. It is possible to cancel setup without saving the change, as described in paragraph 7.11.3.

The value of the flashing digit can be changed by pressing the subkey. The digit is increased by one each time the key is pressed, and from 9 it reverts to 0:

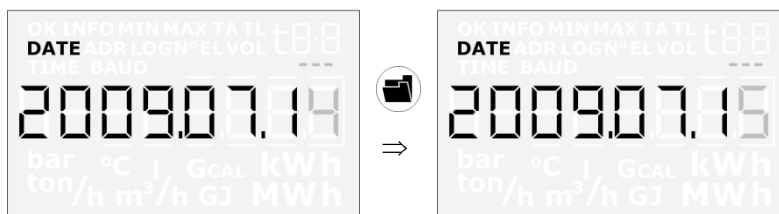

When you press the main key you change to the next digit from right to left:

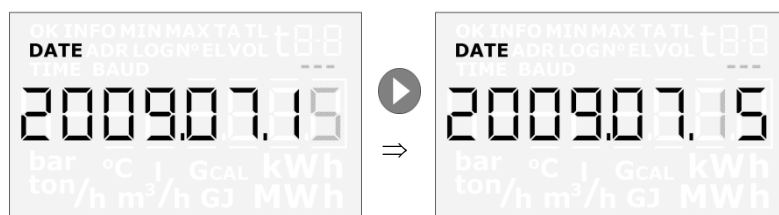

The active digit flashes and this digit can be changed by pressing the subkey. You go from the leftmost to the rightmost digit by pressing the main key.

### 7.11.3 Exit setup menu

When the value of the reading has been changed to the required value, you quit by pressing the main key continuously for 5-6 seconds.

It should be checked whether the value is valid for the reading in question. If so, the value is saved and the new value is displayed together with the “OK” symbol. If not, the old value is displayed without the ”OK” symbol.



The setup menu can be deactivated without saving the change in the following way:

- 1) Switch off the supply to the meter
- 2) Wait until the display is completely blank
- 3) Connect the supply without pressing any keys

Wait a moment without pressing any keys. The legal reading appears and the setup menu is deactivated.

**Note:** After four minutes without activating any keys, the setup menu is deactivated and the display returns to the legal reading. If the “OK” is not displayed, no data have been saved.

### 7.11.4 List of readings supported by the setup menu

Readings supported by the setup menu:

Date

Clock

Input A (preset of register)

Input B (preset of register)



Meter no. of Input A

Meter no. of Input B

Primary M-Bus address

**Note!** Pulse values of Input A and Input B (FF and GG) cannot be changed via the front keys.

## 7.12 Reset via front keys

The meter is fitted with two keys – a main key  and a subkey . It is possible to reset the operating hour counter and the info-event counter by means of the keys on the calculator front.

### 7.12.1 Activate reset menu

The reset menu is activated as follows:

- 1) Select the reading to be reset in the display
- 2) Disconnect the meter supply by removing the supply plug from the meter
- 3) Wait until the reading disappears from the meter, i.e. until the display is totally blank (up to 2.5 min.). Do not activate any keys
- 4) Keep pressing the main key while connecting the supply (by plugging the supply plug into the meter) until no more lines are shown in the display
- 5) The reset menu is now active

Having activated the reset menu either operating hour counter or info-event counter is displayed, the zero flashing:



When the reset menu is active a 0 will be displayed and it will not be possible to change the value. It will only be possible to save the zero or cancel, as described in 7.11.3.

If you try to activate the reset menu of a reading which is not supported by reset, the meter will start in the usual way beginning with the legal reading without starting the reset menu.

### 7.12.2 Exit reset menu

When operating hour counter or info-event counter has been reset, you quit by pressing the main key continuously for 5-6 seconds. Subsequently an "OK" is displayed.



The reset menu can be deactivated without saving the change in the following way:

- 1) Disconnect the meter supply by removing the supply plug from the meter
- 2) Wait until the display is completely blank
- 3) Connect the supply without pressing any keys (plugging the supply plug into the meter)

Wait a moment without pressing any keys. The legal reading appears and the reset menu is deactivated.

Note: If no keys are activated for 4 min., the reset menu is deactivated and the display reverts to legal reading. If the "OK" is not displayed, no data have been saved.

## 8 Flow Sensor

### 8.1 Ultrasound combined with piezo ceramics

Through the latest 20 years ultrasonic measurement has proved the most long-term stable measuring principle for heat measurement. Both experience from ultrasonic meters in operation and repeated reliability tests carried out in Kamstrup's accredited long-term test equipment as well as by AGFW in Germany have documented the long-term stability of ultrasonic meters.

### 8.2 Principles

The thickness of a piezo ceramic element changes when exposed to an electric field (voltage). When the element is influenced mechanically, a corresponding electric charge is generated. Therefore, the piezo ceramic element can function as both sender and receiver.

Within ultrasonic flow measuring there are two main principles: the transit time method and the Doppler method.

The Doppler method is based on the frequency change which occurs when sound is reflected by a moving particle. This is very similar to the effect you experience when a car drives by. The sound (the frequency) decreases when the car passes by.

### 8.3 Transit time method

The transit time method used in MULTICAL® 402 utilizes the fact that it takes an ultrasonic signal sent in the opposite direction of the flow longer to travel from sender to receiver than a signal sent in the same direction as the flow.

The transit time difference of a flow sensor is very small (nanoseconds). Therefore, the time difference is measured as a phase difference between the two 1 MHz sound signals in order to obtain the necessary accuracy.

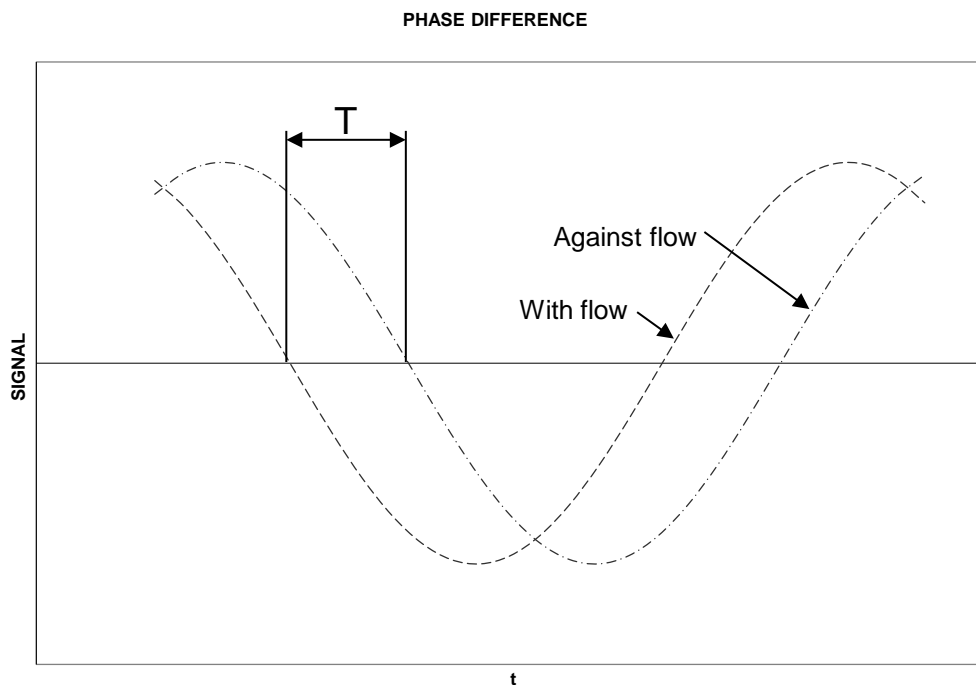

Diagram 4

## MULTICAL® 402

In principle, flow is determined by measuring the flow velocity and multiplying it by the area of the measuring pipe:

$$Q = F \times A$$

where:

$Q$  is the flow

$F$  is the flow velocity

$A$  is the area of the measuring pipe

The area and the length, which the signal travels in the sensor, are well-known factors. The length which the signal travels can be expressed as  $L = T \times V$ , which can also be written as:

$$T = \frac{L}{V}$$

where:

$L$  is the measuring distance

$V$  is the sound propagation velocity

$T$  is the time

$$\Delta T = L \times \left( \frac{1}{V_1} - \frac{1}{V_2} \right)$$

In connection with ultrasonic flow sensors the velocities  $V_1$  and  $V_2$  can be stated as:

$$V_1 = C - F \quad \text{and} \quad V_2 = C + F \quad \text{respectively}$$

where:  $C$  is the velocity of sound in water

Using the above formula you get:

$$\Delta T = L \times \frac{1}{C - F} - \frac{1}{C + F}$$

which can also be written as:

$$\Delta T = L \times \frac{(C + F) - (C - F)}{(C - F) \times (C + F)}$$

⇓

$$\Delta T = L \times \frac{2F}{C^2 - F^2}$$

As  $C \gg F$ ,  $F^2$  can be omitted and the formula reduced as follows:

$$F = \frac{\Delta T \times C^2}{L \times 2}$$

In order to minimize the influence from variations of the velocity of sound in water, the velocity of sound in water is measured by means of the built-in ASIC. For this purpose a number of absolute time measurements between the two transducers are made. These measurements are subsequently converted into the current velocity of sound, which is used in connection with flow calculations.

## 8.4 Signal paths



$q_p$  0.6...1.5 m<sup>3</sup>/h

### 2 parallel tracks

The sound path is parallel with the measuring pipe and is sent from the transducers via reflectors.

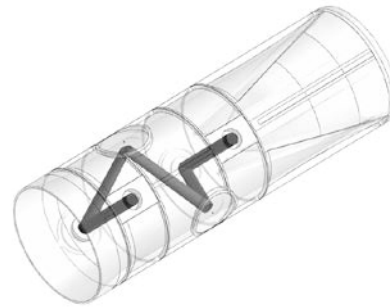

$q_p$  2.5...15 m<sup>3</sup>/h

### Triangle

The sound path covers the measuring pipe in a triangle and is sent from the transducers around the measuring pipe via reflectors.

## 8.5 Flow limits

In the meter's working range from min. cutoff and far beyond  $q_s$  there is a linear connection between the flow rate and the measured water flow.

In practice the highest possible water flow through the sensor will be limited by the pressure in the system or cavitation due to too low back pressure.

If the flow is lower than min. cut off or negative, MULTICAL® 402 does not measure any flow.

According to EN 1434 the upper flow limit  $q_s$  is the highest flow at which the flow sensor may operate for short periods of time (<1h/day, <200h/year) without exceeding max. permissible errors. MULTICAL® 402 has no functional limitations during the period, when the meter operates above  $q_p$ . However, please note that high flow velocities may cause cavitation, especially at low static pressure. See paragraph 6.5 for further details on operating pressure.

## 9 Temperature sensors

MULTICAL® 402 is available with inputs for either Pt100 or Pt500 temperature sensors according to EN 60751 (DIN/IEC 751). A Pt100 or Pt500 temperature sensor respectively is a platinum sensor, of which the nominal ohmic resistance is 100.000 Ω and 500.000 Ω at 0.00°C and 138.506 Ω and 692.528 Ω at 100.00°C respectively. All ohmic resistance values are laid down in the international standard IEC 751, applying to Pt100 temperature sensors. The ohmic resistance values of Pt500 sensors are five times higher. The tables below include resistance values for each degree celcius in [Ω] for both Pt100 and Pt500 sensors:

Pt100										
°C	0	1	2	3	4	5	6	7	8	9
0	100.000	100.391	100.781	101.172	101.562	101.953	102.343	102.733	103.123	103.513
10	103.903	104.292	104.682	105.071	150.460	105.849	106.238	106.627	107.016	107.405
20	107.794	108.182	108.570	108.959	109.347	109.735	110.123	110.510	110.898	111.286
30	111.673	112.060	112.447	112.835	113.221	113.608	113.995	114.382	114.768	115.155
40	115.541	115.927	116.313	116.699	117.085	117.470	117.856	118.241	118.627	119.012
50	119.397	119.782	120.167	120.552	120.936	121.321	121.705	122.090	122.474	122.858
60	123.242	123.626	124.009	124.393	124.777	125.160	125.543	125.926	126.309	126.692
70	127.075	127.458	127.840	128.223	128.605	128.987	129.370	129.752	130.133	130.515
80	130.897	131.278	131.660	132.041	132.422	132.803	133.184	133.565	133.946	134.326
90	134.707	135.087	135.468	135.848	136.228	136.608	136.987	137.367	137.747	138.126
100	138.506	138.885	139.264	139.643	140.022	140.400	140.779	141.158	141.536	141.914
110	142.293	142.671	143.049	143.426	143.804	144.182	144.559	144.937	145.314	145.691
120	146.068	146.445	146.822	147.198	147.575	147.951	148.328	148.704	149.080	149.456
130	149.832	150.208	150.583	150.959	151.334	151.710	152.085	152.460	152.835	153.210
140	153.584	153.959	154.333	154.708	155.082	155.456	155.830	156.204	156.578	156.952
150	157.325	157.699	158.072	158.445	158.818	159.191	159.564	159.937	160.309	160,682
160	161.054	161.427	161.799	162.171	162.543	162.915	163.286	163.658	164.030	164.401

Pt100, IEC 751 Amendment 2-1995-07

Table 8

Pt500										
°C	0	1	2	3	4	5	6	7	8	9
0	500.000	501.954	503.907	505.860	507.812	509.764	511.715	513.665	515.615	517.564
10	519.513	521.461	523.408	525.355	527.302	529.247	531.192	533.137	535.081	537.025
20	538.68	540.910	542.852	544.793	546.733	548.673	550.613	552.552	554.490	556.428
30	558.365	560.01	562.237	564.173	566.107	568.042	569.975	571.908	573.841	575.773
40	577.704	579.635	581.565	583.495	585.424	587.52	589.280	591.207	593.134	595.060
50	596.986	598.911	600.835	602.759	604.82	606.605	608.527	610.448	612.369	614.290
60	616.210	618.129	620.047	621.965	623.883	625.800	627.716	629.632	631.547	633.462
70	635.376	637.289	639.202	641.114	643.026	644.937	646.848	648.758	650.667	652.576
80	654.484	656.392	658.299	660.205	662.111	664.017	665.921	667.826	669.729	671.632
90	673.535	675.437	677.338	679.239	681.139	683.038	684.937	686.836	688.734	690.631
100	692.528	694.424	696.319	698.214	700.108	702.002	703.896	705.788	707.680	709.572
110	711.463	713.353	715.243	717.132	719.021	720.909	722.796	724.683	726.569	728.455
120	730.40	732.225	734.109	735.992	737.875	739.757	741.639	743.520	745.400	747.280
130	749.160	751.038	752.917	754.794	756.671	758.548	760.424	762.299	764.174	766.048
140	767.922	769.795	771.667	773.539	775.410	777.281	779.151	781.020	782.889	784.758
150	786.26	788.493	790.360	792.226	794.091	795.956	797.820	799.684	801.547	803.410
160	805.272	807.133	808.994	810.855	812.714	814.574	816.432	818.290	820.148	822.004

Pt100, IEC 751 Amendment 2-1995-07

Table 9

## 9.1 Sensor types

Type 402-

### Pt500 sensor set

No sensor set	00
Pocket sensor set with 1.5 m cable	0A
Pocket sensor set with 3.0 m cable	0B
Short direct sensor set with 1.5 m cable	0F
Short direct sensor set with 3.0 m cable	0G

## 9.2 Cable influence

### 9.2.1 2-wire sensor set

Usually small and medium-size heat meters just need temperature sensors with relatively short cable lengths. Thus, 2-wire sensor sets can be used with advantage.

Cable lengths and cross sections of the two sensors which are used as temperature sensor set for a heat meter must always be identical, and must neither be shortened nor extended.

The limitations connected to the use of 2-wire sensor sets according to prEN 1434-2:2009 appear from the table below.

Cable cross section [mm <sup>2</sup> ]	Pt100 sensors		Pt500 sensors	
	Max. cable length [m]	Temperature increase [K/m] <i>Copper @ 20 °C</i>	Max. cable length [m]	Temperature increase [K/m] <i>Copper @ 20 °C</i>
0.25	2.5	0.450	12.5	0.090
0.50	5.0	0.200	25.0	0.040

Table 10

Kamstrup supply Pt500 sensor sets with up to 10 m cable (2 x 0.25 mm<sup>2</sup>)

## 9.3 Installation

### 9.3.1 Electrical connection

The two paired 2-wire sensors must be mounted in terminals 5 and 6 (T1), and 7 and 8 (T2). The polarity of temperature sensors T1 and T2 is unimportant.

See the position of the terminals below:

	Terminal no.	Standard heat and cooling measurement
<b>T1</b>	5-6	Sensor in forward pipe (red)
<b>T2</b>	7-8	Sensor in return pipe (blue)

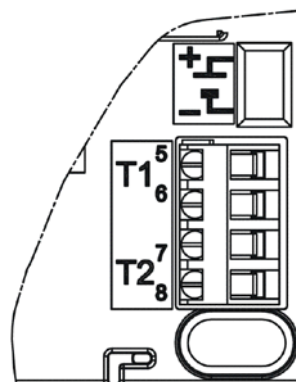

## 9.4 Pocket sensors

The pocket sensor is a Pt500 cable sensor, constructed with 2-wire silicone cable and closed with a D 5.8 mm shrunk on stainless steel tube which protects the sensor element.

The steel tube is mounted in a sensor pocket (immersion pipe) which has an inner diameter of 6 mm and an outer diameter of 8 mm. Sensor pockets are available with R $\frac{1}{2}$  (conical  $\frac{1}{2}$ "") connection in stainless steel and in lengths of 65, 90 and 140 mm. The sensor construction with separate immersion pipe permits replacement of sensors without having to cut off the flow. Furthermore, the wide range of immersion pipe lengths ensures that the sensors can be mounted in all existing pipe dimensions.

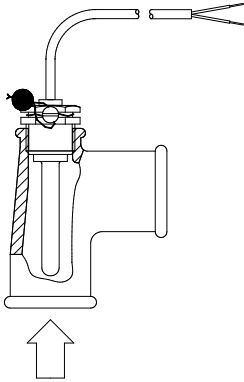

Figure 18

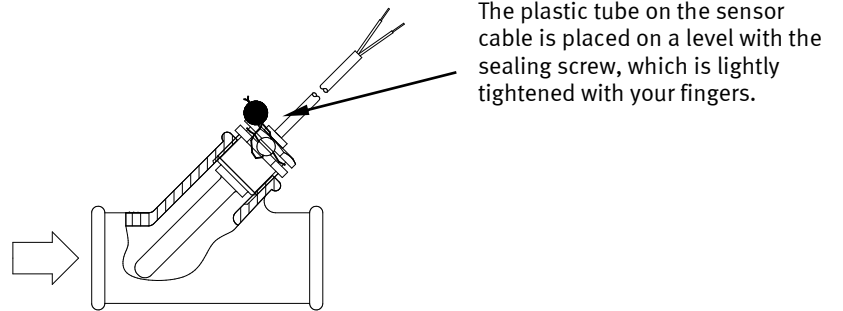

Figure 19

The stainless steel pockets can be used for mounting in PN25 systems!

### 9.5 Pt500 short direct sensor set

The Pt500 short direct sensor has been constructed according to the European heat meter standard EN 1434-2. The sensor has been designed for direct mounting in the measuring medium, i.e. without sensor pocket, whereby a very fast response to temperature changes from e.g. domestic water exchangers is obtained.

The sensor is based on two-wire silicone cable. The sensor pipe is made of stainless steel and has a diameter of 4 mm at the point where the sensor element is placed. Furthermore, it can be immediately mounted in many flow sensor types which reduces the installation costs.

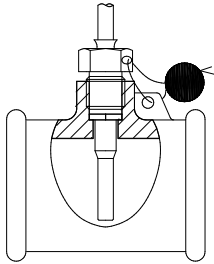

Figure 20

The sensor can be mounted in special tee-pieces, which are available for 1/2", 3/4" and 1" pipe installations.

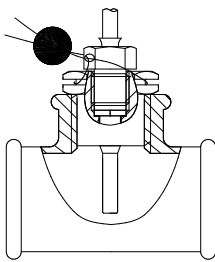

Figure 21

Furthermore, the short direct sensor can be mounted by means of a R1/2 or R3/4 for M10 nipple in a standard 90° tee.

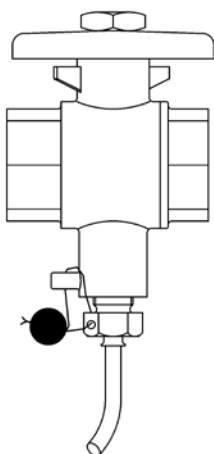

Figure 22

In order to obtain the best possible serviceability during meter replacement the short direct sensor can be placed in a ball valve with sensor socket.

Ball valves with sensor socket are available in G1/2, G3/4 and G1.

Item	6556-474	6556-475	6556-476
	G1/2	G3/4	G1

Max. 130°C and PN16

## 10 Power supply

MULTICAL® 402 must always be internally supplied with 3.6 VDC ( $\pm 0.1$  VDC) via the built-in supply plug.

Supply	Type	402-	□	□□	□
No module					0
Battery, 2 x AA					1
Battery, D-cell					2
230 VAC supply module					7
24 VAC supply module					8

The four above-mentioned supply modules are included in the comprehensive type test, to which MULTICAL® 402 has been subjected. Within the framework of the type approval, the CE-declaration and the manufacturer's guarantee no other types of power supplies than the ones listed above can be used.

Note: MULTICAL® 402 cannot be supplied by 24 VDC.

### 10.1 Built-in 2 x AA-cell lithium battery

The 2 x AA-cell lithium battery is in most applications sufficient to power MULTICAL® 402 throughout an operating period of 6 years (see paragraph 10.3).



Note: AA-cell lithium batteries include approx. 0.7 g lithium each and are therefore not comprised by transport restrictions.

## 10.2 Built-in D-cell lithium battery

A D-cell lithium battery should be selected for MULTICAL® 402 when you require the longest possible battery lifetime. Depending on the application in question the D-cell can power MULTICAL® 402 for up to 16 years (see paragraph 10.4).



Note: D-cell lithium batteries include approx. 4.5 g lithium each and are therefore comprised by transport restrictions. See document 5510-408\_DK-GB-DE for further details on transportation of lithium batteries.

### 10.3 Battery lifetimes of 2 x AA-cell

Estimated battery lifetime in years

2 x AA-cell battery pack	Normal response (24 s.)		Fast response (4 s.)	
	Wall mounted Battery < 30°C	Pipe mounted Battery < 40°C	Wall mounted Battery < 30°C	Pipe mounted Battery < 40°C
<b>402-0-00</b> Without module	6	5	-	-
<b>402-0-10</b> Data + 2 pulse inputs (VA, VB)	Monthly: 6 Daily: 6 Hourly: - Min.: -	Monthly: 5 Daily: 5 Hourly: - Min.: -	-	-
<b>402-0-11</b> Data + 2 pulse outputs (CE, CV)	-	-	-	-
<b>402-0-20</b> M-Bus + 2 pulse inputs (VA, VB)	Monthly: 6 Daily: 6 Hourly: - Min.: -	Monthly: 5 Daily: 5 Hourly: - Min.: -	-	-
<b>402-0-21</b> M-Bus + 2 pulse outputs (CE, CV)	-	-	-	-
<b>402-0-29</b> M-Bus + 2 pulse inputs (VA, VB), MCIII Data Package	Monthly: 6 Daily: 6 Hourly: - Min.: -	Monthly: 5 Daily: 5 Hourly: - Min.: -	-	-
<b>402-0-30/31/35/38</b> Wireless M-Bus, EU, 868 MHz, Mode C1 Wireless M-Bus, EU, 868 MHz, Mode T1 OMS (Ind. Key) Wireless M-Bus, EU, 868 MHz, Mode C1 (Ind. Key) Alt. Reg. +VA, VB Wireless M-Bus, C1, Fixed Network, (Ind. Key)	6	5	-	-
<b>402-0-37</b> Wireless M-Bus, EU, 868 MHz, Mode T1 (Common Key)	-	-	-	-
<b>402-0-40/41 (By hand-held systems)</b> Radio, EU, 434 MHz, int. ant.	-	-	-	-
<b>402-0-42/44</b> Radio, EU, 434 MHz, int.+ext. ant.+ 2 pulse inputs (VA, VB)	-	-	-	-
<b>402-0-43/45</b> Radio, EU, 434 MHz, int.+ext. ant + 2 pulse outputs (CE, CV)	-	-	-	-
<b>402-0-50/52/54/56</b> Radio, SE, 444 MHz, int. ant./ ext. ant. + 2 pulse inputs (VA, VB)	-	-	-	-

## 10.4 Battery lifetimes of D-cell

Estimated battery lifetime in years

D-cell battery	Normal response (24 s.)		Fast response (4 s.)	
	Wall mounted Battery < 30°C	Pipe mounted Battery < 40°C	Wall mounted Battery < 30°C	Pipe mounted Battery < 40°C
<b>402-0-00</b> Without module	16	12	8	6
<b>402-0-10</b> Data + 2 pulse inputs (VA, VB)	Monthly: 16 Daily: 16 Hourly: 12 Min.: -	Monthly: 12 Daily: 12 Hourly: 10 Min.: -	Monthly: 8 Daily: 8 Hourly: 6 Min.: -	Monthly: 6 Daily: 6 Hourly: 5 Min.: -
<b>402-0-11</b> Data + 2 pulse outputs (CE, CV) *	Monthly: 10 Daily: 8 Hourly: 6 Min.: -	Monthly: 8 Daily: 6 Hourly: 5 Min.: -	-	-
<b>402-0-20</b> M-Bus + 2 pulse inputs (VA, VB)	Monthly: 16 Daily: 16 Hourly: 12 Min.: -	Monthly: 12 Daily: 12 Hourly: 10 Min.: -	Monthly: 8 Daily: 8 Hourly: 6 Min.: -	Monthly: 6 Daily: 6 Hourly: 5 Min.: -
<b>402-0-21</b> M-Bus + 2 pulse outputs (CE, CV)*	Monthly: 10 Daily: 8 Hourly: 6 Min.: -	Monthly: 8 Daily: 6 Hourly: 5 Min.: -	-	-
<b>402-0-29</b> M-Bus + 2 pulse inputs (VA, VB), MCIII Data Package	Monthly: 16 Daily: 16 Hourly: 12 Min.: -	Monthly: 12 Daily: 12 Hourly: 10 Min.: -	Monthly: 8 Daily: 8 Hourly: 6 Min.: -	Monthly: 6 Daily: 6 Hourly: 5 Min.: -
<b>402-0-30/31/35/38</b> Wireless M-Bus, EU, 868 MHz, Mode C1 Wireless M-Bus, EU, 868 MHz, Mode T1 OMS (Ind. Key) Wireless M-Bus, EU, 868 MHz, Mode C1 (Ind. Key) Alt. Reg. +VA, VB Wireless M-Bus, C1, Fixed Network, (Ind. Key)	16	12	8	6
<b>402-0-37</b> Wireless M-Bus, EU, 868 MHz, Mode T1 (Common Key)	11	8	6	5
<b>402-0-40/41 (By hand-held systems)</b> Radio, EU, 434 MHz, int. ant.	Monthly: 12 Daily: 11 Hourly: - Min.: -	Monthly: 10 Daily: 9 Hourly: - Min.: -	Monthly: 6 Daily: 5 Hourly: - Min.: -	Monthly: 5 Daily: 4 Hourly: - Min.: -
<b>402-0-42/44</b> Radio, EU, 434 MHz, int.+ext. ant.+ 2 pulse inputs (VA, VB)	Monthly: 12 Daily: 11 Hourly: - Min.: -	Monthly: 10 Daily: 9 Hourly: - Min.: -	Monthly: 6 Daily: 5 Hourly: - Min.: -	Monthly: 5 Daily: 4 Hourly: - Min.: -
<b>402-0-43/45</b> Radio, EU, 434 MHz, int.+ext. ant + 2 pulse outputs (CE, CV) *	Monthly: 8 Daily: 7 Hourly: - Min.: -	Monthly: 6 Daily: 5 Hourly: - Min.: -	-	-
<b>402-0-50/52/54/56</b> Radio, SE, 444 MHz, int. ant./ ext. ant. + 2 pulse inputs (VA, VB)	Monthly: 12 Daily: 11 Hourly: - Min.: -	Monthly: 10 Daily: 9 Hourly: - Min.: -	Monthly: 6 Daily: 5 Hourly: - Min.: -	Monthly: 5 Daily: 4 Hourly: - Min.: -

\*) –Pulse duration: 32 ms. -Standard CCC-code –Average flow: 30% of qp –Average cooling: < 40 K  
Operating conditions influence the battery lifetime. Please contact Kamstrup for further information.

## 10.5 Supply Module 230 VAC

This PCB module is galvanically separated from the mains voltage and is suitable for direct 230 V mains installation. The module includes a double-chamber safety transformer, which fulfils the double-isolation requirements when the calculator top is mounted. The power consumption is less than 1 VA/1 W.



National regulations for electric installations must be observed. The 230 VAC module can be connected/disconnected by the utility's personnel, whereas the fixed 230 V installation into the meter panel must be carried out by an authorized electrician.

## 10.6 Supply Module 24 VAC

This PCB module is galvanically separated from the 24 VAC mains supply and is both suitable for industrial installations with joint 24 VAC supply and individual installations, which are supplied by a separate 230/24 V safety transformer in the meter panel. The module includes a double-chamber safety transformer, which fulfils the double-isolation requirements when the calculator top is mounted. The power consumption is less than 1 VA/1 W.



National regulations for electric installations must be observed. The 24 VAC module can be connected/disconnected by the heating station's personnel, whereas the fixed 230/24 V installation in the meter panel must only be carried out by an authorized electrician.

# MULTICAL® 402

The module is specially suited for installation together with a 230/24 V safety transformer, e.g. type 66-99-403, which can be installed in the meter panel before the safety relay. When the transformer is used the total power consumption of the meter incl. the 230/24 V transformer will be lower than 1.7 W.



## 10.7 Change of supply unit

The supply unit for MULTICAL® 402 can be changed from mains supply to battery or visa versa as the needs of the utility change. Thus, it can be an advantage to change mains supplied meters to battery meters in buildings under construction where the mains supply can be unstable or periodically missing.

The change from battery to mains supply does not require reprogramming as MULTICAL® 402 does not include an information code for outworn battery.

## 10.8 Mains cables

MULTICAL® 402 is available with 1.5 m mains cable, type "H05 VV-F" for either 24 VAC or 230 VAC. Mains cables with copper conductors and a conductor cross section of 2 x 0.75 mm<sup>2</sup> must be connected via a max. 6 A fuse.

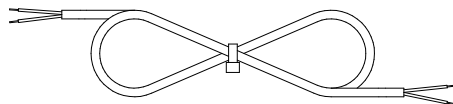

Mains cable, type 5000-286 (2 x 0.75 mm<sup>2</sup>)

"H05 VV-F" is the designation of a strong PVC mantle, which withstands max. 70°C. Therefore, the mains cable must be installed with sufficient distance to hot pipes etc.

## 10.9 Danish regulations for the connection of mains operated meters

**Installation to electric mains operated equipment for consumption registration ([www.sik.dk](http://www.sik.dk), safety notification electric services no. 27/09, February 2009).**

The consumption of energy and resources (electricity, heat, gas and water) of the individual consumer is to an increasing extent registered by electronic meters, and often equipment for remote reading and remote control of both electronic and non-electronic meters is used.

General regulations for carrying out installations must be observed. However, the following modifications are permitted:

- If meter or equipment for remote reading or remote control is double-isolated, it is not necessary to run the protective conductor all the way to the connection point. This also applies if the connection point is a plug socket provided that it is placed in a canning which is sealable or can be opened with key or tool only.

If meter or equipment used for remote reading and remote control is connected to a safety transformer mounted in the panel and direct connected to the branch conductor, no on-off switch or separate overcurrent protection in either primary or secondary circuit is required, provided that the following conditions are fulfilled:

- The safety transformer must either be inherently short-circuit-proof or fail-safe
- The conductor of the primary circuit must either be short-circuit protected by the overcurrent protection of the branch conductor or short-circuit safely run.
- The conductor of the secondary circuit must have a cross section of at least 0.5 mm<sup>2</sup> and a current value which exceeds the absolute maximum current deliverable by the transformer
- It must be possible to separate the secondary circuit, either by separators, or it must appear from the installation instructions that the secondary circuit can be disconnected at the transformer's terminals

### General information

Work on the fixed installation, including any intervention in the group panel, must be carried out by an authorized electrician.

It is not required that service work on equipment comprised by this notification as well as connection and disconnection of the equipment outside the panel is carried out by an authorized electrician. These tasks can also be carried out by persons or companies, who professionally produce, repair or maintain equipment if only the person carrying out the work has the necessary expert knowledge.

# 11 Communication Modules

Plug-in modules can be mounted in the module area of MULTICAL® 402. In this way the meter can be adapted to various applications.

All plug-in modules are included in the comprehensive type test, to which MULTICAL® 402 has been subjected. Within the framework of the type approval, the CE-declaration and the manufacturer’s guarantee no other types of plug-in modules than the ones listed below can be used.

Plug-in modules are available in three versions:

- without pulse inputs/outputs
- with pulse output for energy (CE) and volume (CV)
- with pulse inputs (VA and VB) for accumulation of pulses from e.g. water meters

Reconfiguration between pulse inputs and pulse outputs is not necessary with MULTICAL® 402. When a module with pulse outputs is mounted in MULTICAL® 402, the meter will automatically be configured for pulse outputs. When a module with pulse inputs is mounted in MULTICAL® 402, the meter will automatically be configured for pulse inputs.

## 11.1 Communication Modules

Modules	Type	402-	□	□□
No module				00
Data + 2 pulse inputs (VA, VB)				10
Data + 2 pulse outputs (CE, CV)				11
M-Bus + 2 pulse inputs (VA, VB)				20
M-Bus + 2 pulse outputs (CE, CV)				21
M-Bus + 2 pulse inputs (VA, VB), MCIII Data Package				29
Wireless M-Bus, EU, 868 MHz, Mode C1 (Ind. Key)				30
Wireless M-Bus, EU, 868 MHz, Mode T1 OMS (Ind. Key)				31
Wireless M-Bus, EU, 868 MHz, Mode C1 (Ind. Key) Alt. Reg . +VA,VB				35
Wireless M-Bus, EU, 868 MHz, Mode T1 (Common Key)				37
Wireless M-Bus, C1, Fixed Network, (Ind. Key)				38
Radio, EU, 434 MHz, Int. Ant., NET0				40
Radio, EU, 434 MHz, Int. Ant., NET1				41
Radio, EU, 434 MHz, Int.+Ext. Ant., NET0 + 2 pulse inputs (VA, VB)				42
Radio, EU, 434 MHz, Int.+Ext. Ant., NET0 + 2 pulse outputs (CE, CV)				43
Radio, EU, 434 MHz, Int.+Ext. Ant., NET1 + 2 pulse inputs (VA, VB)				44
Radio, EU, 434 MHz, Int.+Ext. Ant., NET1 + 2 pulse outputs (CE, CV)				45
Radio, SE, 444 MHz, Int. Ant., NET0 + 2 pulse inputs (VA, VB)				50
Radio, SE, 444 MHz, Int. Ant., NET1 + 2 pulse inputs (VA, VB)				52
Radio, SE, 444 MHz, Ext. Ant., NET0 + 2 pulse inputs (VA, VB)				54
Radio, SE, 444 MHz, Ext. Ant., NET1 + 2 pulse inputs (VA, VB)				56

## 11.2 Pulse outputs (CE and CV)

The pulse duration of pulse outputs for energy and volume can be ordered at 32 ms. or 0.1 s. After delivery the pulse duration can be changed by means of the PC program METERTOOL (see paragraph 14)

The resolution of the pulse outputs always follows the least significant digit of the energy and volume readings respectively (see CCC-codes, paragraph 3.3.1).

The pulse outputs can be configured under the country code to display one of the following registers per pulse output:

E1 (Heat energy)

E3 (Cooling energy)

V1 (Volume)

TA2 (Totalized energy or volume)

TA3 (Totalized energy or volume)

The pulse output readings cannot be changed after configuration.

The pulse outputs have been configured with the following default values:

Meter function	Output C (16-17) - CE	Output D (18-19) - CV	Country codes
Verification mode*	E1 and E3**	V1	All
Heat meter	E1	V1	1XX 2XX 4XX 9XX
Heat meter	E1	E3	3XX
Cooling meter	E3	V1	5XX
Heat/cooling meter	E1	E3	6XX
Volume meter	V1	V1	7XX 8XX

\*) The pulse outputs are not configurable in verification mode

\*\*\*) All measured energy is emitted as pulses

The original configuration of the pulse duration (see paragraph 3.7) is maintained. The pulse resolution remains unchanged both in verification mode and in normal mode.

The pulse resolution follows the display (determined by the CCC-code). For example CCC=119: 1 pulse/kWh and 1 pulse/0.01 m<sup>3</sup>

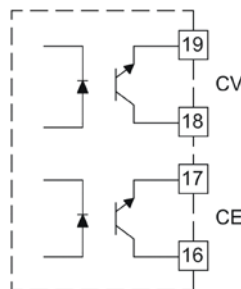

The pulse outputs are designed with darlington optocouplers, which makes them suitable for most signal types. Please note the polarity when making the connection. See paragraph 2.2 re electrical data of the pulse outputs.

### 11.3 Pulse inputs VA and VB

The pulse inputs are physically placed on the plug-in modules and are well suited for the collection of pulses from e.g. water meters with Reed switch output or water meters with electronic pulse output.

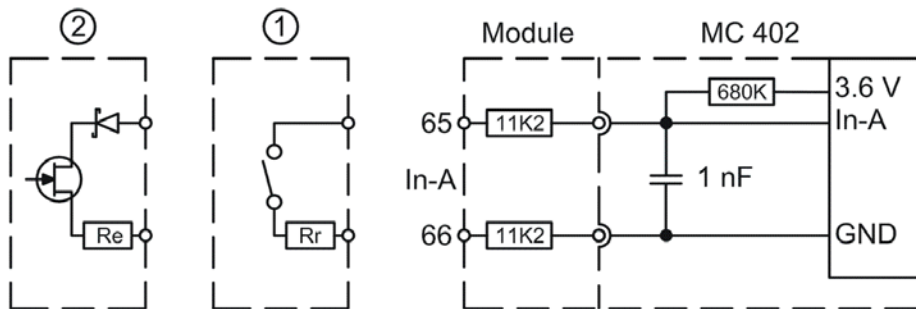

#### 1 Water meter with Reed switch output

Pulse inputs VA and VB are bounce damped and therefore well suited for receiving signals from a Reed switch. The Reed switch output often has a built-in resistance ( $R_r$ ) in order to protect the Reed switch itself. Pulse inputs VA and VB function with  $R_r$  values up to 10 k $\Omega$ .

#### 2 Water meter with electronic pulse output

The pulse inputs are also well suited for receiving signals from a water meter with electronic pulse output of min. 30 ms. pulse duration. The pulse inputs must have a "LOW" level of  $\leq 0.4$  V and a "HIGH" level of  $\geq 2.5$  V. If the electronic pulse output has a polarity safety, it should be fitted with a Schottky-diode, and a possible serial resistor ( $R_e$ ) should be max. 500  $\Omega$ .

The inputs are configured via the FF and GG codes as shown in the table in paragraph 3.6. In the absence of other information from the customer the inputs will be configured as FF=24 and GG=24 (10 l/pulse). After delivery the FF and GG codes can be changed by means of the PC program METERTOOL (see paragraph 14)

## 11.4 Modules

### 11.4.1 Data + pulse inputs (type: 402-0-10) (PCB 5550-1025)

The module has a galvanically separated data port which interoperates with the KMP protocol (see paragraph 12). The data output can be used for e.g. connection of external communication units or other hardwired data communication which it is not expedient to carry out via optical communication on the meter's front.

See paragraph 11.1.2 Pulse inputs VA and VB concerning the function of the pulse inputs.

The module includes data connection, which can e.g. be used for the external reading plug meant for Kamstrup's hand-held terminal or hardwiring of PC connection.

The data connection is galvanically isolated by optocouplers, which makes it necessary to use data cable type 66-99-105 or 66-99-106 in order to adapt the signal to RS232 level which suits a PC or Kamstrup's hand-held terminal.

See paragraph 12. *Data Communication* for information on data sequences and protocols. If the computer does not have a COM-port, data cable with USB type 66-99-098 can be used.

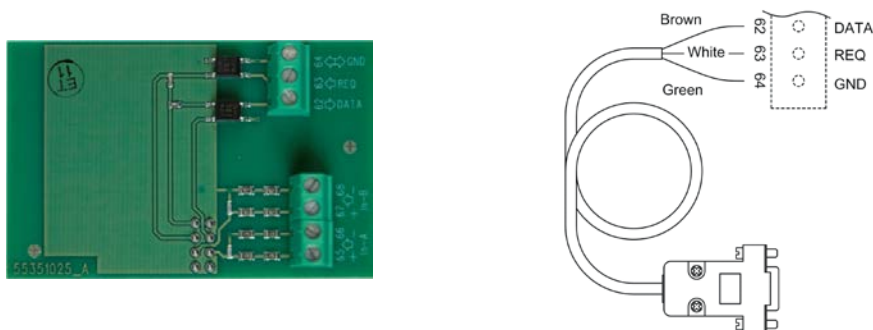

### 11.4.2 Data + pulse outputs (type: 402-0-11) (PCB 5550-1026)

See paragraph 11.4.1 re data connection and paragraph 11.2 re pulse outputs.

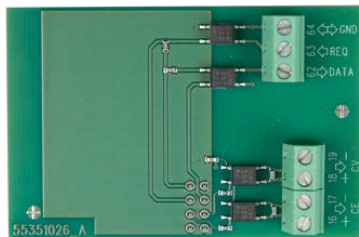

### 11.4.3 M-Bus + pulse inputs (type: 402-0-20) (PCB 5550-1030)

The M-bus module is powered through the M-bus network and is thus independent of the meter's internal supply. Two-way communication between M-bus and energy meter is carried out via optocouplers providing galvanic separation between M-bus and meter. The module supports both primary, secondary and enhanced secondary addressing. The module can communicate at communication speeds of 300, 2400 or 9600 baud and automatically detects the speed used.



See paragraph 11.3 Pulse inputs VA and VB concerning the function of the pulse inputs.

**11.4.4 M-Bus + pulse outputs (type: 402-0-21) (PCB 55501007)**

The M-bus module is powered through the M-bus network and is thus independent of the meter’s internal supply. Two-way communication between M-bus and energy meter is carried out via optocouplers providing galvanic separation between M-bus and meter. The module supports both primary, secondary and enhanced secondary addressing. The module can communicate at communication speeds of 300, 2400 or 9600 baud and automatically detects the speed used.



See paragraph 11.2 re the pulse outputs.

**11.4.5 M-Bus module with MC-III data package + pulse inputs (402-00-29) (PCB 5550-1140)**

The M-Bus module 670029 comprises the same data packet as M-Bus module 6604 for MC III/66-C and module 660S for MCC/MC 401.

The module can e.g. be used together with the old M-Bus master with display, old regulators and old reading systems not supporting the newer M-Bus modules.



**11.4.6 Wireless M-Bus (Type: 402-0-30 and 402-0-35) (PCB 5550-1029/1203)**

The Wireless M-Bus module has been designed to form part of Kamstrup’s hand-held Wireless M-Bus Reader system, which operates in the licence-free frequency band in the 868 MHz area.

The communication protocol is in C-mode according to the standard EN13757-4.

The Wireless M-Bus module supports individual encryption and comes fitted with internal antenna as well as connection for external antenna.

Module 402-0-35 has two pulse inputs VA and VB.

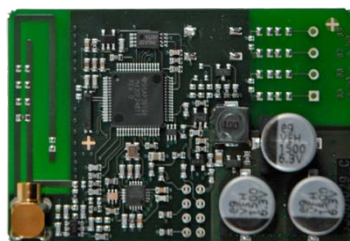

**11.4.7 Wireless M-Bus (Type: 402-0-31) (PCB – 5550-1387)**

The Wireless M-Bus module has been developed to be integrated in an "Open Metering System" (OMS) solution without further configuration, and operates within the unlicensed frequency band in the 868 MHz area.

The communication protocol is T-mode according to OMS specifications: Volume 2: Primary Communication Version 4.0.2, and the module uses one-way communication, data being automatically sent from the meter every 15 minutes after installation.

The T1 OMS module supports individual encryption and comes with internal antenna as well as MCX connection for external antenna.

Photo see above paragraph 11.4.6.

#### 11.4.8 Wireless M-Bus (Type: 402-0-37) (PCB – 5550 1075)

The Wireless M-Bus module complies with the T-mode protocol of the standard EN13757-4 and operates within the licence-free frequency band in the 868 MHz area.

The Wireless M-Bus module 402-0-37 includes a common encryption key in order to secure the data from the meter.

The Wireless M-Bus module comes fitted with an internal antenna.



#### 11.4.9 Wireless M-Bus (Type: 402-0-38) (PCB: 5550-1352)

The Wireless M-Bus module has been specifically developed to be integrated in a Wireless M-Bus network (Radio Link Network) and operates within the unlicensed frequency band in the 868 MHz area.

The communication protocol is C-mode according to the standard EN13757-4 and the module uses one-way communication, data being automatically sent from the meter every 96 seconds after installation.

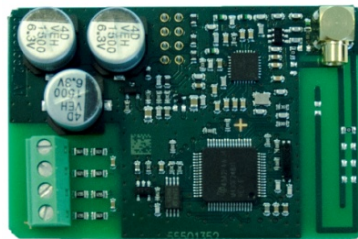

#### 11.4.10 Radio (Type: 402-0-40 and 402-0-41) (PCB 5550-1040)

These radio modules are your first choice for reading via Kamstrup's hand-held reading systems, e.g. USB Meter Reader and hand-held terminal MT Pro, which operate in the licence-free frequency band in the 434 MHz area.

The radio module comes fitted with internal antenna.

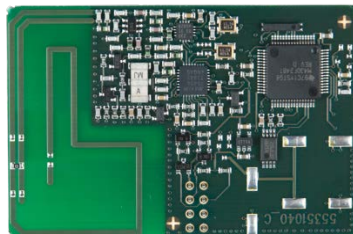

**11.4.11 Radio (Type: 402-0-42 and 402-0-44) (PCB 5550-1072)**

The radio modules have been optimized to form part of a Kamstrup radio network system, which operates in the licence-free frequency band in the 434 MHz area, but can also be used for the hand-held reading systems in the same frequency area.

The radio module comes fitted with internal antenna as well as connection for external antenna and two pulse inputs.

See paragraph 11.2 re. the pulse outputs.

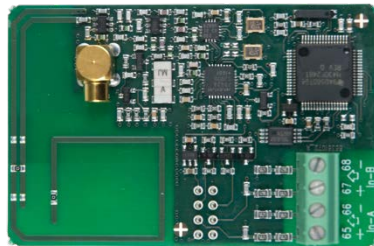

**11.4.12 Radio (Type: 402-0-43 and 402-0-45) (PCB 5550-1072/1074)**

The radio modules have been optimized to form part of a Kamstrup radio network system, which operates in the licence-free frequency band in the 434 MHz area, but can also be used for the hand-held reading systems in the same frequency area.

The radio module comes fitted with internal antenna as well as connection for external antenna and two pulse outputs.

See paragraph 11.2 re the pulse outputs.

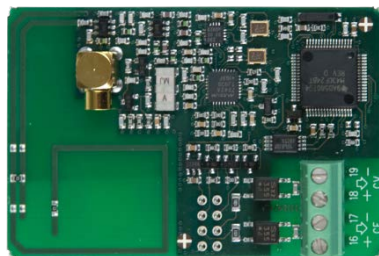

**11.4.13 Radio (Type 402-0-50, 402-0-52, 402-0-54 and 402-0-56) (PCB 5550-1060/1076/1077/1078)**

The radio modules have been optimized to form part of Kamstrup’s radio network systems but can also be used for hand-held reading systems which operate within the Swedish licence demanding frequency band in the 444 MHz area.

The radio module is available with two pulse inputs as well as optional internal antenna or connection for external antenna.

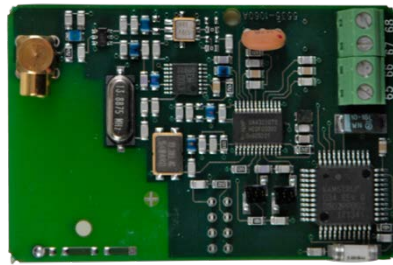
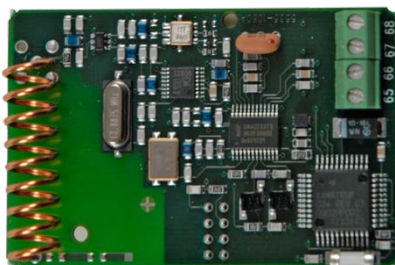

## 11.5 Mounting an external antenna



Mounting an external antenna it must be secured that the antenna cable does not become caught between the PCB and the stay of the cover. Replacing or mounting modules the meter must be without current. The same applies when mounting an external antenna.

## 11.6 Retrofitting modules

Modules for MULTICAL® 402 are also supplied separately for retrofitting. The modules are configured and ready for installation from the factory. However, some of the modules need individual configuration after installation which is possible by means of the PC program METERTOOL (see paragraph 14).

Module		Possible configuration after installation
Data + pulse inputs	<b>10</b>	Pulse values of VA and VB are changed via METERTOOL.
Data + pulse outputs	<b>11</b>	Pulse durations of CE and CV are changed via METERTOOL.
M-Bus + pulse inputs	<b>20 + 29</b>	Pulse values of VA and VB are changed via METERTOOL. Primary and secondary M-Bus addresses can be changed via METERTOOL or M-Bus. Furthermore, monthly logger data can be selected instead of yearly logger data via M-bus.
M-Bus + pulse outputs	<b>21</b>	Pulse durations of CE and CV are changed via METERTOOL. Primary and secondary M-Bus addresses can be changed via METERTOOL or M-Bus. Furthermore, monthly logger data can be selected instead of yearly logger data via M-bus.
Wireless M-Bus	<b>30+31</b>	N/A
Wireless M-Bus + pulse inputs	<b>35</b>	Pulse values of VA and VB are changed via METERTOOL.
Wireless M-Bus	<b>37+38</b>	N/A
Radio + pulse inputs	<b>42+44</b>	Pulse values of VA and VB are changed via METERTOOL. Switching between NET0 and NET1 via MT Pro.
Radio + pulse outputs	<b>43+45</b>	Pulse durations of CE and CV are changed via METERTOOL. Switching between NET0 and NET1 via MT Pro.
Radio + pulse inputs	<b>50+52 54+56</b>	Pulse values of VA and VB are changed via METERTOOL. Switching between NET0 and NET1 via MT Pro.

## 12 Data Communication

### 12.1 MULTICAL® 402 Data Protocol

Internal data communication in MULTICAL® 402 is based on the Kamstrup Meter Protocol (KMP) which provides a quick and flexible reading structure and also fulfils future requirements to data reliability.

The KMP protocol is used in all Kamstrup consumption meters launched from 2006 onwards. The protocol is used for the optical eye and via plug pins for the module area. Thus, modules with e.g. M-bus interface use the KMP protocol internally and the M-bus protocol externally.

The KMP protocol has been designed to handle point to point communication in a master/slave system (e.g. a bus system) and is used for data reading of Kamstrup energy meters.

*Software and parameter protection*

The meter’s software has been implemented in a Flash and cannot be changed, neither deliberately nor by mistake. The legal parameters cannot be changed via data communication without breaking the legal seal and short circuiting the ”total programming lock”.

*Software conformity*

Software check sum, based on CRC16, is available via data communication and in the display.

*Integrity and authenticity of data*

All data parameters include type, measuring unit, scaling factor and CRC16 check sum. Every produced meter includes a unique identification number.

Two different formats are used in the communication between master and slave. Either a data frame format or an application acknowledgement format.

- A request from master to slave is always sent in a data frame
- The response from the slave can either be sent in a data frame or as an application acknowledgement

The data frame is based on the OSI model using the physical layer, the data link layer and the application layer.

Number of bytes in each field	1	1	1	0-?	2	1
Field designation	Start byte	Destination address	CID	Data	CRC	Stop byte
OSI – layer			Application layer			
	Data link layer					
	Physical layer					

The protocol is based on half duplex serial synchronous communication with setup: 8 data bits, no parity and 2 stop bits. The data bit rate is 1200 or 2400 baud. CRC16 is used in both request and response.

Data is transferred byte for byte in a binary data format, where the 8 data bits represent one byte of data.

Byte Stuffing is used for extending the value range.

### 12.1.1 Register IDs of MULTICAL® 402

ID	Register	Description
1003	Date	Current date (YYMMDD)
1002	Clock	Current hour (hhmmss)
99	InfoCode	Info code register, current
113	InfoEventCounter	Info event counter
1004	HourCounter	Operating hour counter
60	Energy1	Energy register 1: Heat energy
63	Energy3	Energy register 3: Cooling energy
97	Energy8	Energy register 8: [m <sup>3</sup> x T1]
110	Energy9	Energy register 9: [m <sup>3</sup> x T2]
68	Volume1	Volume register V1
86	Temp1	Current forward temperature
87	Temp2	Current return temperature
89	Temp1-Temp2	Current differential temperature
74	Flow1	Current water flow
80	Power1	Current power
84	InputA	Input register VA
85	InputB	Input register VB
64	TariffReg2	Tariff register 2
65	TariffReg3	Tariff register 3
66	TariffLimit2	Tariff limit 2
67	TariffLimit3	Tariff limit 3
223	HighResVolume	High-resolution volume register for test purposes
155	HighResEnergy	High-resolution energy register for test purposes
98	LogDaySetUp	Target date (reading date)
146	AvrTemp1(y)	Year-to-date average of T1
147	AvrTemp2(y)	Year-to-date average of T2
149	AvrTemp1(m)	Month-to-date average of T1
150	AvrTemp2(m)	Month-to-date average of T2
229	AutoIntT1Average	T1 average above latest autointegration
230	AutoIntT2Average	T2 average above latest autointegration
123	MaxFlow1Date(y)	Date of this year's max.
124	MaxFlow1(y)	This year's max. value
125	MinFlow1Date(y)	Date of this year's min.
126	MinFlow1(y)	This year's min. value
127	MaxPower1Date(y)	Date of this year's max.
128	MaxPower1(y)	This year's max. value
129	MinPower1Date(y)	Date of this year's min.
130	MinPower1(y)	This year's min. value
138	MaxFlow1Date(m)	Date of this month's max.
139	MaxFlow1(m)	This month's max. value
140	MinFlow1Date(m)	Date of this month's min.
141	MinFlow1(m)	This month's min. value
142	MaxPower1Date(m)	Date of this month's max.
143	MaxPower1(m)	This month's max. value
144	MinPower1Date(m)	Date of this month's min.
145	MinPower1(m)	This month's min. value
152	ProgNo	Program no. ABCCC
153	ConfNo1	Config no. DDDEE
168	ConfNo2	Config. no. FFGGNPP
1001	SerialNumber	Serial no. (unique number of each meter)
112	MeterNo(high)	Customer number (8 most significant digits)
1010	MeterNumber(low)	Customer number (8 least significant digits)
114	MeterNo(inputA)	Meter no. of VA
104	MeterNo(inputB)	Meter no. of VB
1005	MeterType	Software edition
184	MBusBotDispPriAddr	Primary M-Bus address
185	MBusBotDispSecAddr	Secondary M-Bus address
154	Checksum	Software checksum

### 12.1.2 Data protocol

Utilities and other relevant companies who want to develop their own communication driver for the KMP protocol can order a demonstration program in C# (.net based) as well as a detailed protocol description (in English language).

## 12.2 Optical eye

For data communication via the optical interface an optical eye can be used. The optical eye must be located at the front of the calculator, just above the IR-diode as shown on the photo below. Please note that the optical eye contains a very powerful magnet that should be protected with the magnet protector when not in use.

Different variants of the optical eye can be found in the list of accessories (see chapter 3.2.1).



### 12.2.1 Current saving at the optical eye

In order to limit the current consumption of the circuit around the IR diode, the circuit is not permanently switched on.

It is activated by either keystroke or communication via the optical eye.

The circuit remains switched on for 30 min. after end of communication or after latest keystroke.

## 13 Calibration and verification

To be able to carry out test/verification of MULTICAL® 402 with minimum time consumption the meter has a verification mode. When the meter is in verification mode, the program procedure is approx. four times faster than in normal mode (like in fast mode). Furthermore, test mode includes some extra functions which are described below.

Note: MULTICAL® 402 uses approx. twice as much current in verification mode. Under normal circumstances, however, the meter will only be in verification mode e.g. 9 hours per five years, and this is without importance for the meter's total battery lifetime.

The calculator can be calibrated either by means of "Autointegration, as described in paragraph 13.2.5, or using verification equipment type 66-99-372 /-373 together with the PC-program METERTOOL (see paragraph 14).

### 13.1 Connector

The verification and module connector is placed under the front cover and thereby sealed by the installation seal.

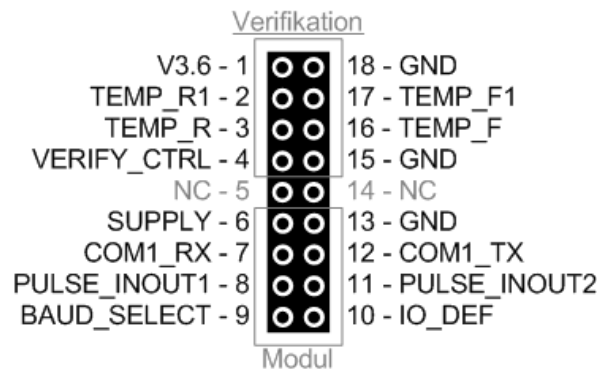

The upper part of the connector is used for "verification". This part is normally sealed to prevent inadvertent access.

The bottom part of the connector is used for one of the available plug-in modules for MULTICAL® 402 (see paragraph 11). The module connector is usually not sealed.

Pin no.	Name	Description
1	V3.6	3.6 V internal supply on PCB. Connected to supply plug + pole via diode.
2	TEMP_R1	Return temperature, voltage input
3	TEMP_R	Return temperature, current output
4	VERIFY_CTRL	Verification control (legal lock). NC/V3.6 = locked; GND = open
5	NC	Not connected
6	SUPPLY	Power supply direct connected to supply plug + pole.
7	COM1_RX	Serial communication – meter's RX
8	PULSE_INOUT1	Pulse input A/output CE, depending on IO_DEF
9	BAUD_SELECT	Baud rate selector. NC/V3.6 = 1200; GND = 4800
10	IO_DEF	Input/output definition. NC/V3.6 = inputs; GND = outputs
11	PULSE_INOUT2	Pulse input B/output CV, depending on IO_DEF
12	COM1_TX	Serial communication – meter's TX
13	GND	Ground – 0 volt
14	NC	Not connected
15	GND	Ground – 0 volt
16	TEMP_F	Forward temperature, current output
17	TEMP_F1	Forward temperature, power input
18	GND	Ground – 0 volt

### 13.2 Test – verification mode

#### 13.2.1 Meter cycle

The meter can run two different measuring cycles: normal cycle and fast/verification cycle. The measuring cycles are outlined below. Normal or fast measuring cycle is configured from the factory via the country code (three last characters of the type number) .

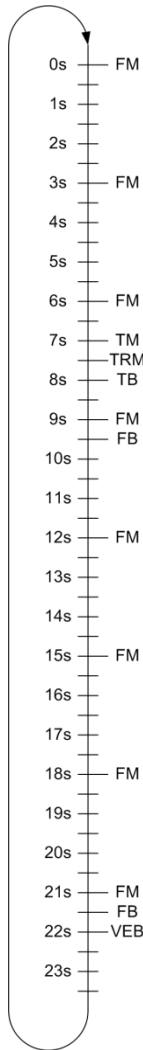

Normal cycle (24 seconds)

Abbreviation	Description
FM	Flow measurement
TM	Temperature measurement
TRM	Temperature reference measurement
FB	Flow calculation
TB	Temperature calculation
VEB	Volume and energy calculation
B	Calculation and integration

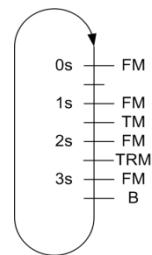

Fast/verification cycle (4 seconds)

In the sketches on the previous page, each letter abbreviation represents a meter task. The abbreviations are explained in the table below.

Abbreviation	Description
FM	Flow measurement
TM	Temperature measurement Measurement of T1 and T2 sensors starts
TRM	Temperature reference measurement Measurement of reference resistors starts
FB	Flow calculation Calculation of a flow average based on flow measurements saved since the latest flow calculation
TB	Temperature calculation Calculation of a T1 and a T2 value based on the latest measurement of reference resistors, T1 and T2 sensors. At the same time a dT (T1-T2) value is calculated
VEB	Volume and energy calculation Calculation of a volume value based on an average of flow measurements saved since the latest VE calculation in proportion to the period of time passed since the latest VE calculation. This volume is integrated in the meter's volume register. Calculation of an energy value based on volume and dT value for the period since the latest VE calculation. This energy is integrated in the meter's energy register.
B	Calculation Flow, temperature, volume and energy are calculated as described in FB, TB and VEB respectively.

### 13.2.2 Meter modes

The meter can operate in three different modes: normal, fast and verification mode. In normal mode the meters runs the normal cycle (24 sec.). In fast and verification mode the meter runs the fast/verification cycle (4 sec.).

The difference between fast mode and verification mode is the fact that verification mode opens relevant verification registers in the display, and at the same time different verification functions are opened.

#### 13.2.2.1 Choice of mode

Via the country code (the last three characters of the type number) the meter is configured to start in either normal mode (24 sec.) or fast mode (4 sec.)

Furthermore, the meter can be forced into verification mode by disconnecting the supply and restarting the meter while keeping both front buttons pressed.

The meter remains in verification mode until the supply is disconnected and the meter restarted. However, a time-out secures that the meter returns from verification mode to normal mode after 9 hours.

It is indicated that the meter is in verification mode in that the three dots in the right side of the display flash like in fast mode. At the same time a P for "test mode" is shown in that of the big 7-segments which is placed farthest to the left in the display.

**13.2.3 High-resolution verification registers**

When the meter is in verification mode, reading of two high-resolution verification registers is opened: a volume register and an energy register.

These registers are integrated at the same time as the legal volume and energy registers, with the same values. However, the units of the high-resolution registers must be [ml] for volume and [10mWh] for energy, whereas the units of the legal registers can be configured depending on meter size.

**13.2.3.1 Reset of registers**

As long as the meter remains in verification mode double key pressure – i.e. both keys remain pressed for 5-6 seconds – functions as reset of the high-resolution verification registers. Thus, both registers are reset.

**13.2.4 Verification pulses**

When the meter is in verification mode it can emit verification pulses with a resolution that appears from the table in paragraph 13.3.3.

The verification pulses are established via plug-in module 402-0-11. The pulse outputs are galvanically separated from the meter. (Pulse Interface type 66-99-109 cannot be used for MULTICAL® 402)

	<b>Type</b>	<b>402-</b>	<input type="checkbox"/>	<input type="checkbox"/>
Data + 2 pulse outputs (CE, CV)				<b>11</b>

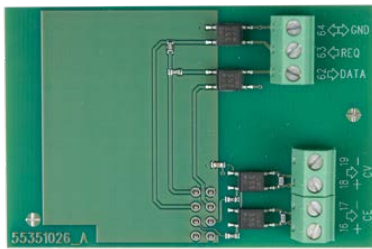

**Technical data of verification pulses via 402-0-11 module**

Energy 16-17      Volume: 18-19

Type	Open collector (OB)
Pulse duration	3.9 ms.
Max. pulse frequency:	120 Hz
External voltage	5...30 VDC
Current	1...10 mA
Residual stress	$U_{CE} \approx 1 \text{ V}$ at 10 mA
Leak current	$I_{CE} \leq 1 \text{ } \mu\text{A}$ at 25°C
Electrical isolation	2 kV
Max. cable length	5 m
Resolution	see table 11

### 13.2.4.1 Use of Pulse Tester

The high-resolution energy and volume pulses can be connected to Kamstrup's Pulse Tester type 66-99-279 as shown in the below drawing. It is necessary to connect pull-up resistors of e.g. 33 k $\Omega$  as shown in the drawing.

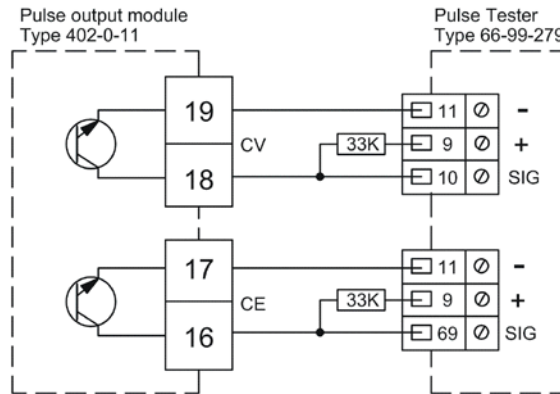

**13.2.5 Autointegration**

The purpose of autointegration is to test the calculator’s accuracy. During autointegration the flow through the meter must be cut off to make it possible to read volume and energy counted during autointegration without the meter continuing normal counting in the registers afterwards.

Autointegration requires input of a volume as well as a number of integrations, over which the meter is to distribute the volume. MULTICAL® 402 is configured for autointegration = 100 litres to be distributed over 40 integrations from the factory.

Furthermore, the high-resolution verification registers are reset to ensure that they include the result of the autointegration alone after the autointegration, not an accumulation with previously counted values.

Before starting autointegration, VerifyCtrl of the module plug must be connected to the meter’s ground – see below sketch. Subsequently the sub-key is pressed continuously for 5-6 seconds, upon which the "OK" symbol in the display is switched on and the integration starts. When autointegration starts the high-resolution registers are reset, whereas the legal volume registers continue counting.

Subsequently, the meter starts the integrations. With each integration the temperatures are measured and calculated, volume is counted and the energies (corresponding to the volume counted and the temperatures calculated) are calculated and totalized.

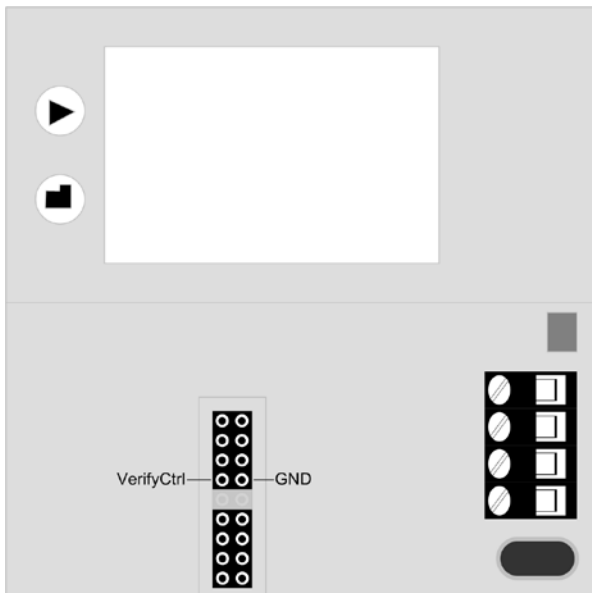

**Note:** Remember to set the meter in verification mode, as described in section 13.2.2.1 on page 87, before starting the autointegration.

After autointegration all volume and energy registers – incl. the high-resolution verification registers – have been counted with the given volume and the calculated energies. Furthermore, the average of the temperatures measured during autointegration has been saved in two temperature verification registers, T1 average and T2 average.

For calculation of accuracy and precision the registers with RID 223, 155, 229 and 230 – volume, energy, T1 average and T2 average respectively – can be read out after the autointegration.

Verification registers		RID
Energy	EHighRes	155
Volume	VHighRes	223
T1 average	T1average_AutoInt	229
T2 average	T2average_AutoInt	230

## 13.3 Handling of different test methods

### 13.3.1 Standing start/stop

Standing start/stop is a method used for testing the flow meter's accuracy. The test must be carried out while the meter is mounted in a flow test stand. The flow through the meter is cut off. Now the verification registers are reset and the flow is opened for a period of time while the water running through the meter is being collected. Having switched off the flow again the volume of the collected water is compared to the volume counted by the meter. Generally standing start/stop requires bigger test volume than flying start/stop.

#### 13.3.1.1 Standing start/stop at display reading of V' and Q'

Condition: MULTICAL® 402 must be in verification mode.

V' and Q' are reset by double key pressure – i.e. both keys are pressed continuously for 5-6 seconds. Thus, both registers are reset.

The selected display reading is updated at intervals of 4 sec.

#### 13.3.1.2 Standing start/stop using pulse outputs

Condition: MULTICAL® 402 must be in verification mode.

Verification pulses are connected as described in paragraph 13.2.4 above.

### 13.3.2 Flying start/stop

“Flying start/stop” is the most frequently used method for testing the flow meter's accuracy. The test must be carried out while the meter is mounted in a flow test stand and the water flow through the meter is constant.

The meter's counting of volume and energy in the high-resolution verification registers can be controlled by the PULSE-INOUT1 (pin 8) connection of the verification plug. The meter only counts as long as PULSE-INOUT1 is connected. Based on the time, during which PULSE-INOUT1 is connected, and the fact that the flow through the meter/flow stand is constant, the theoretical volume through the meter can be calculated and compared to the volume counted by the meter.

As the meter counts volume and energy every 4 seconds (in verification mode – see paragraph 13.2.4), and as counts around start and stop flanks must be weighted in relation to the time between flank and calculation, it can take up to four seconds from PULSE-INOUT1 has been disconnected until the result can be read. Furthermore, the time between two flanks must not be less than 4 seconds.

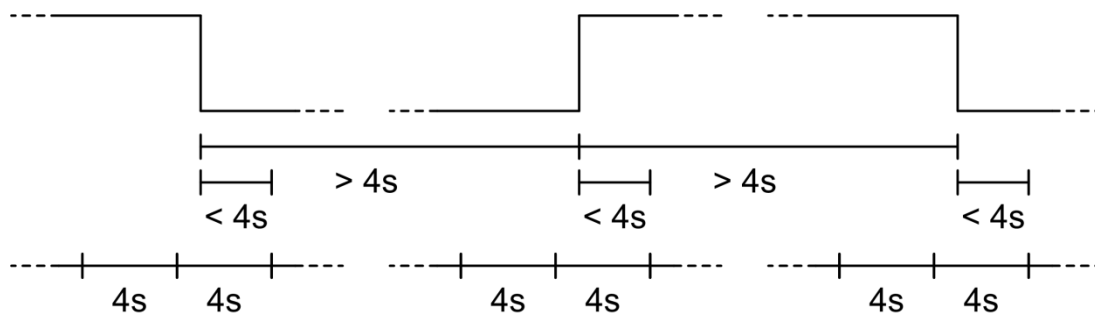

At the very moment PULSE-INOUT1 is connected the verification registers are reset. Maximum 4 seconds after this the verification registers are counted the first time followed by normal counting in the registers every 4 seconds.

# MULTICAL® 402

The first count after having connected PULSE-INOUT1 is weighted in relation to the time from the flank for this counting so that only volume and energy corresponding to the period are counted.

When PULSE-INOUT1 is disconnected, the meter will make a last counting of the verification registers within four seconds, whereupon counting in the registers stops. The last counting after having disconnected PULSE-INOUT1 is weighted in relation to the time from the previous calculation for the flank, so that only volume and energy corresponding to this period are counted.

As long as PULSE-INOUT1 is disconnected the values measured during the previous period with PULSE-INOUT1 connected remain in the verification registers.

The verification registers can either be read from the display or via the serial data connection while PULSE-INOUT1 is disconnected:

Verification registers		RID
Energy	EHighRes	155
Volume	VHighRes	223

### 13.3.3 Pulse resolution in verification mode

The resolution of the pulse outputs depends on the actual meter size. In addition to the pulse resolution of MULTICAL® 402 the table includes the resolutions of Kamstrup’s previous compact meters; MULTICAL® Compact and MULTICAL® 401.

Meter size [m³/h]			Energy [pulses/kWh]			Volume [pulses/litre]			Flow @ 120 Hz [l/h]
MCC	MC-401	<b>MC-402</b>	MCC	MC-401	<b>MC-402</b>	MCC	MC-401	<b>MC-402</b>	<b>MC-402</b>
-	qp 0.6	qp 0.6	-	1000	1000	-	100	100	4320
qp 0.75	-	-	1000	-	-	100	-	-	
qp 1.5	qp 1.5	qp 1.5	1000	1000	1000	100	100	100	4320
qp 2.5	-	qp 2.5	1000	-	1000	100	-	100	4320
-	qp 3.0	-	-	500	-	-	50	-	
-	qp 3.5	qp 3.5	-	500	500	-	50	50	8640
-	qp 6.0	qp 6.0	-	250	250	-	25	25	17280
-	qp 10	qp 10	-	125	125	-	12.5	12.5	34560
-	qp 15	qp 15	-	125	125	-	12.5	12.5	34560

Table 11

### 13.4 True energy calculation

During test and verification the heat meter's energy calculation is compared to the "true energy" calculated according to the formula of EN 1434-1:2007 or OIML R75:2002.

The PC-program METERTOOL from Kamstrup includes an energy calculator which is suitable for this purpose:

The true energy at the most frequently used verification points is indicated in the table below.

T1 [°C]	T2 [°C]	$\Delta\Theta$ [K]	Flow [Wh/0.1 m <sup>3</sup> ]	Return [Wh/0.1 m <sup>3</sup> ]
42	40	2	230,11	230,29
43	40	3	345,02	345,43
53	50	3	343,62	344,11
50	40	10	1146,70	1151,55
70	50	20	2272,03	2295,86
80	60	20	2261,08	2287,57
160	40	120	12793,12	13988,44
160	20	140	14900,00	16390,83

## 14 METERTOOL HCW

### 14.1 Introduction

The Kamstrup Software product “**METERTOOL HCW**” (66-99-724) is used for the configuration of **MULTICAL® 402** as well as other Kamstrup heat, cooling and water meters. For MULTICAL®402 it is used for reconfiguration, flow sensor adjustment as well as test/verification.

#### 14.1.1 System requirements

METERTOOL requires minimum Windows XP SP3, Windows 7 Home Premium SP1 or newer as well as Windows Internet Explorer 5.01 or newer.

<b>Minimum:</b>	1 GB RAM	<b>Recommended:</b>	4 GB RAM
	10 GB free HD space		20 GB free HD space
	Display resolution 1280 X 720		1920 x 1080
	USB - connection		
	Printer installed		

Administrator rights to the PC are required in order to install and use the programs. The programs must be installed under the log-in of the person who is to use the programs.

#### 14.1.2 Interface

The following interfaces can be used:

Verification equipment	type	66-99-372	Verification of 402-W (Pt500) and total/partial reconfiguration
Verification equipment	type	66-99-373	Verification of 402-T (Pt500) and total/partial reconfiguration
USB prog. cable	type	66-99-097	Used for total programming and flow sensor adjustment
Com prog. cable	type	66-99-108	Used for total programming and flow sensor adjustment
Optical eye USB	type	66-99-099	Partial reconfiguration
Optical eye COM port	type	66-99-102	Partial reconfiguration
USB 3-wire	type	66-99-098	Partial configuration via module

Using equipment with Kamstrup USB, the USB driver must be installed before connection.

#### 14.1.3 Installation

Check that system requirements are fulfilled.

Close other open programs before starting the installation.

Download the METERTOOL software from Kamstrup’s FTP-server and follow the program’s directions through the installation.

During installation the program METERTOOL HCW detects whether a USB-driver for the optical read-out head is installed. If not, you will be asked if you would like to install it. Answer yes to this question.

When the installation has been completed, the icon “METERTOOL HCW” will appear in the ‘All Programs’ menu under ‘Kamstrup METERTOOL’ (or from the menu ”start” for Windows XP) and as a link on the desktop. Double-click on link or icon in order to start the program.

## 14.2 METERTOOL HCW for MULTICAL® 402

### 14.2.1 Start-up and connection

It is important to be familiar with the calculator's functions before starting programming.

The Kamstrup Software product "METERTOOL HCW" (66-99-724) is used for MULTICAL® 402.



MULTICAL® 402 with USB data cable (66-99-097)

MULTICAL® 402 with data cable, RS232 (66-99-108)

There are 2 modes in which to set the program: Basic mode and Advanced mode. In basic mode the date and time can be set and the meter details can be read. In advanced mode other more advanced features are available as well. See below.

Basic	Meter details
	Change date and Time
Advanced	Meter details
	Change date and Time
	Verification
	Module setup
	Print Label
	Certificates
Flow sensor adjustment (MC402)	

## MULTICAL® 402

Before running the program, connect your optical read-out head to your computer and place the head on the lower right-hand corner of the calculator front, resting the read-out head on the two plastic studs. Press any of the buttons on the meter once to enable communication through the optical eye.

Start up METERTOOL HCW and click “Connect” in METERTOOL HCW.

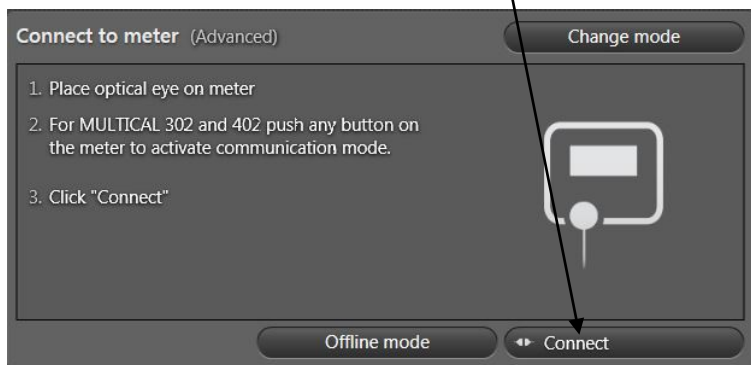

In response METERTOOL HCW displays a picture of MULTICAL® 402 with information on S/W revision etc.

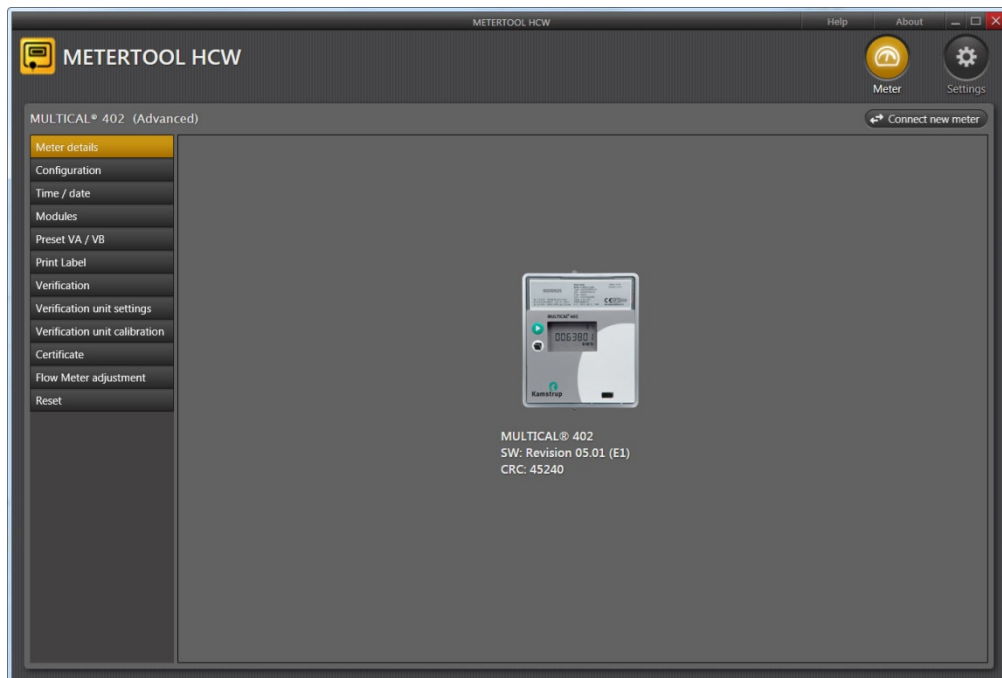

From the menu in the left side of the screen a number of different options are available, depending on mode (Basic/Advanced).

## 14.3 How to use METERTOOL HCW

### 14.3.1 Configuration (Basic/Advanced Mode)

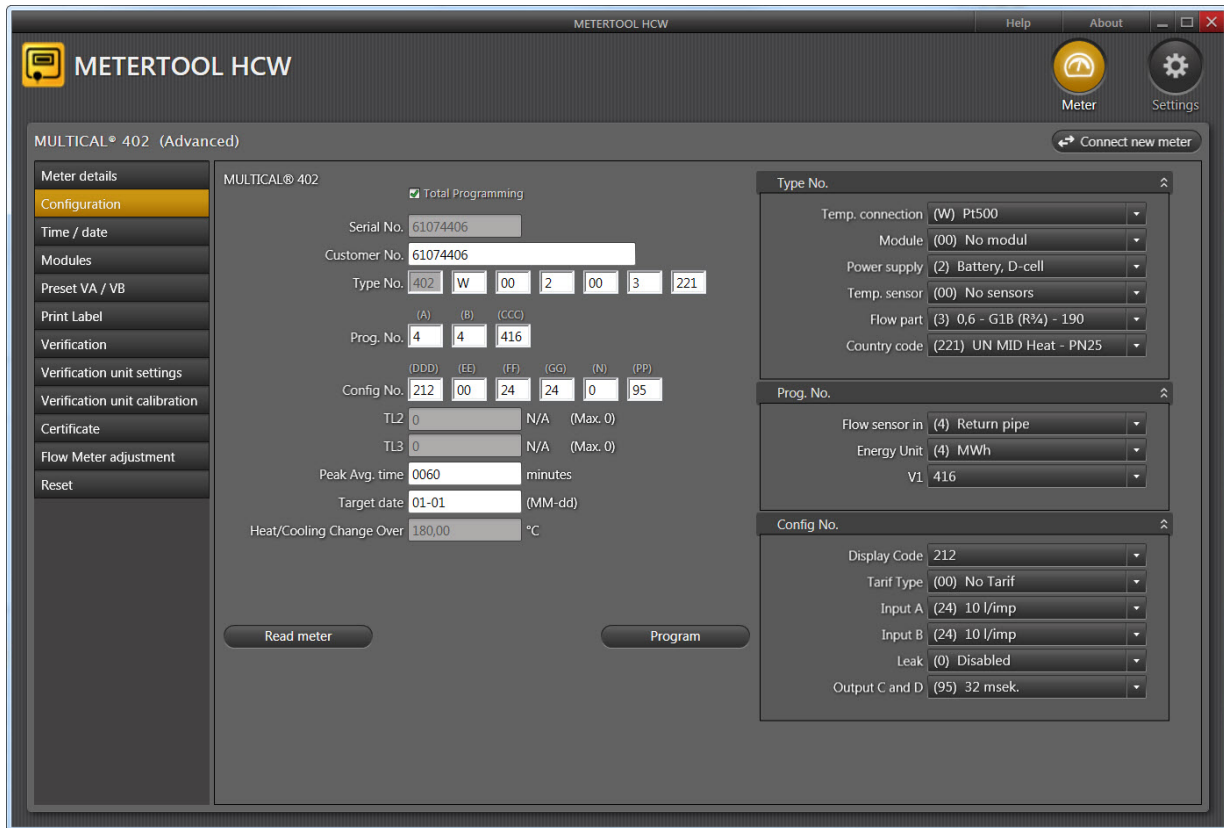

The configuration of MULTICAL® 402 can be read out directly. The program is self-explanatory as to most coding numbers (see text in "combo-boxes"), further details can be found in the respective paragraphs of the technical description.

There are two programming options "Partial programming" and "Total programming".

"Partial programming" does not allow change of coding which is important to energy calculation, e.g. Type No. and Prog. No.

By means of "Total programming" it is possible to change the remaining values too. Programming is only possible if data cable 66-99-097 or 66-99-108, alternatively verification cable 66-99-372 or 66-99-373, is used and the meter's factory/verification seal is broken. Before use, current handling and re-verification requirements must be checked.

It is not possible to change the serial number as it is a unique number allocated to the meter during production.

"Heat/Cooling Change Over" can be disabled depending on the meter type in question.

Partial/Total  
programming

TOOL HCW

(Advanced)

MULTICAL® 402

Total Programming

Serial No. 61074406

Customer No. 61074406

Type No. 402 W 00 2 00 3 221

Prog. No. (A) 4 (B) 4 (CCC) 416

Config No. (DDD) 212 (EE) 00 (FF) 24 (GG) 24 (N) 0 (PP) 95

TL2 0 N/A (Max. 0)

#### 14.3.2 Time / date (Basic/Advanced Mode)

In this menu the built-in clock in the meter can be read out and adjusted either manually or by setting the meter to the clock of the PC on which METERTOOL is running.

#### 14.3.3 Modules (Advanced Mode)

The menu “Modules” is used for configuration of module data for modules mounted in the meter’s module position . See paragraph 11.4 - Modules.

#### 14.3.4 Preset VA / VB (Advanced Mode)

Presets the register values of the two extra pulse inputs for water and electricity meters.

#### 14.3.5 Print Label (Advanced Mode)

Initiates printing of meter label. Reading of the meter configuration is required before printing can take place.

#### 14.3.6 Verification (Advanced Mode)

See separate paragraph, 14.3 Verification with METERTOOL HCW.

#### 14.3.7 Verification unit settings (Advanced Mode)

See separate paragraph, 14.3 Verification with METERTOOL HCW.

#### 14.3.8 Verification unit calibration (Advanced Mode)

See separate paragraph, 14.3 Verification with METERTOOL HCW. Used for changing between temperature set points during calibration.

#### 14.3.9 Certificate (Advanced Mode)

Initiates printing of verification certificates.

#### 14.3.10 Flow Curve Adjustment (Advanced Mode)

Please, see section 14.4.

### 14.3.11 Reset (Advanced Mode)

There are 4 resets: Normal reset, data logger reset, total reset and static info code reset.

Normal reset: The backup log is updated, the calculator is restarted and the configuration parameters reloaded.

Note! This reset does not affect any registers.

Data logger reset: The calculator's data protocol is reset, which affects the year, month, day and hour log as well as the info code and configuration log.

Total Reset: Resets all historical as well as legal registers.

Static info code reset: The Info code stays in the meter's display until a static info code reset is performed, and only if the meter is configured for "Manual Reset of info codes".

This does not reset the info code logger.

## 14.4 METERTOOL HCW Settings

By clicking the "Settings" tab the following can be changed:

### 14.4.1 Change language

The program language can be changed to 6 different languages: Danish, German, English, French, Polish and Russian.



### 14.4.2 COM-port settings

The COM-port can be selected manually instead of the automatically selected default setting.

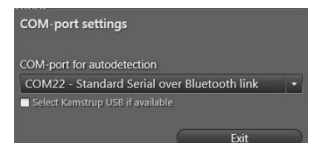

### 14.4.3 Update program

In this menu the METERTOOL program can be updated if a newer revision is available on Kamstrup's FTP-server.

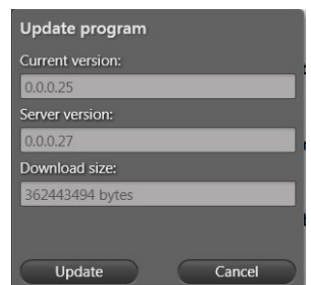

### 14.4.4 Update database

In this menu the METERTOOL database can be updated if a newer revision is available on Kamstrup's FTP-server.

Update database	Current version:	Server version:	Download size:	
MC21 / RowIQ 2101	201309201602	201306191054	35765760 bytes	Update
RowIQ 3100	201306200926	201306200926	35634688 bytes	Update
MC302	201310171026	201311220959	23489924 bytes	Update
MC402	201310011459	201311051239	28590582 bytes	Update
MC601	201309251251	201309251251	34106880 bytes	Update
MC602	201311111020	201311111020	51598848 bytes	Update
MC801	201308191426	201311251645	25848120 bytes	Update
UP4	201306161607	201311271609	46935552 bytes	Update

**14.4.5 Backup & Restore databases**

Verification data as well as equipment data can be saved and backed up using this menu.

**14.4.6 Install USB driver**

This button manually installs the USB driver used for the optical read-out head.

**14.4.7 Help button**

**Contact**

The contact button provides links to Kamstrup’s website and mailbox.

**Output**

Shows the latest activities/functions used in the program.

**User manual**

Provides a link to the user manual for the meter on Kamstrup’s website.

**14.4.8 About button**

Lists the METERTOOL program versions and revision numbers as well as all sub-programs, incl. their type numbers and revision numbers, for the entire METERTOOL HCW program.

**14.4.9 Application**

Double-click on link or icon in order to start the program.

Click “Connect” to get in contact with the meter.

Activate “Configuration” in order to start meter configuration.

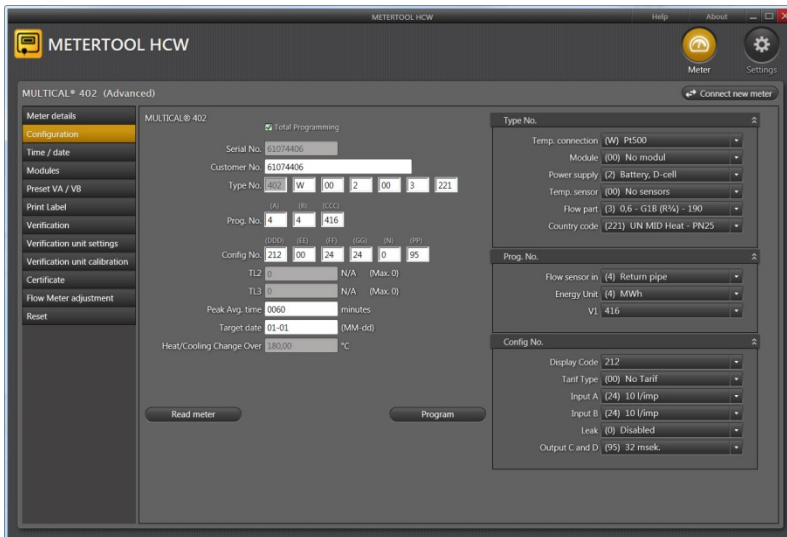

Enter the present configuration by activating "Read meter".

Enter the required changes of coding and activate "Program" in order to carry out the changes in the meter.

If USB interface is used, it must be connected before the program is opened.

## 14.5 Verification of MULTICAL® 402 using METERTOOL HCW

### 14.5.1 General information

Verification of MULTICAL® 402 requires verification equipment as well as input of verification data into the METERTOOL HCW program.

### 14.5.2 Verification equipment

Verification equipment, e.g. type 66-99-372 is used for verification of the MULTICAL®402 calculator. Verification comprises Energy verification of "E1" (66-99-372) and "E3" (66-99-373), test of volume inputs "VA" and "VB".

Different temperatures are simulated for the two sensor inputs "T1" and "T2". Together with auto-integration these temperatures form the basis of the verification of the energy calculation (see paragraph 13.2.5 Autointegration).

The equipment was primarily constructed for use in laboratories which test and verify heat meters, but can also be used for performance test of the meter.

The computer program "METERTOOL HCW" type 66-99-724 is used for configuration, test and verification.

The verification equipment for MULTICAL® 402 is supplied with USB interface (type 66-99-098) as well as corresponding driver software. During installation this interface creates a "virtual COM port" which figures as an optional COM port in the METERTOOL HCW software. As the "virtual COM port" only exists when the equipment is connected, the verification equipment *must* be connected to the computer before the program "METERTOOL HCW" is started.

Furthermore, the verification equipment requires mains supply via the included mains adapter.



Verification does not apply to temperature and flow sensors.

The verification equipment is available in two different types, depending on the MULTICAL® 402 type used and the temperature points to be tested.

66-99-372 Standard (EN1434/MID) Type 402-W (2-wire Pt500)	T1 [°C]	T2 [°C]	$\Delta\Theta$ [K]
	43	40	3
	80	60	20
	160	20	140
66-99-373 Standard (EN1434) Type 402-T (2-wire Pt500)	T1 [°C]	T2 [°C]	$\Delta\Theta$ [K]
	12	15	-3
	9	17	-8
	5	20	-15

For other equipment variants (types or temperature points), please contact Kamstrup A/S.

**14.5.3 Function**

Verification equipment type 66-99-372 and 66-99-373 is housed in a standard MULTICAL® base and comprises battery, connection PCB, verification PCB, microprocessor, control relays and precision resistors. The connection between verification equipment and MULTICAL® 402 consists of a 16-pole test connector. During verification the temperature sensors must be dismantled from the terminal block.

During the test the calculator is supplied by the battery. The verification PCB is powered with 12 VDC by the enclosed external mains adapter. The microprocessor starts auto-integration and temperature simulation is obtained by means of fixed precision resistors, which are automatically changed via relays controlled by the microprocessor.

After the test the computer reads all registers in the calculator and compares the values to the calculated values.

The calibration result in percentage for each test point can be stored in the computer under the serial number of the tested MULTICAL® 402 to be printed out later on a test certificate.

**14.5.4 Verification data**

The first time METERTOOL HCW and the verification equipment is used a number of calibration data must be entered into the menu "Verification unit settings" in the METERTOOL program. Calibration data is electronically included in the verification equipment (also enclosed with the verification equipment as a certificate on paper). In order to transfer calibration data from the equipment to the program select "Verification" from the menu "Settings" and activate "Read".

Calibration data is now transferred to and saved in the METERTOOL HCW program.

The calibration data of the equipment and the program verification data are compared every time verification equipment is connected in order to secure that verification data is updated if the calibration data of the equipment have been changed. For instance this can be due to recalibration of verification equipment. Calibration data of the verification equipment can be maintained by changing verification data in the program METERTOOL and writing the new data into the equipment. In order to avoid unintentional change of calibration data this writing is protected by a password, which can be obtained from Kamstrup A/S.

Calibration data include test points, permissible error, uncertainty, ambient temperature (fixed value) and number of integrations per test.

Having entered verification data, the program automatically calculates the true k-factor in accordance with the formula of EN 1434 and OIML R75:2002.



### 14.5.5 Verification

The verification program menu is opened by activating "Verification".

Click on "Start verification" in order to begin test/verification.

When the test has been completed, the result will be displayed. If the result can be approved, click on "Save". The result is now saved in the database under the serial number of the calculator. You can save several results under one serial number without overwriting earlier results.

### 14.5.6 Certificate

If you want to print a certificate with saved results, select "Certificate". The test/verification result can subsequently be found according to serial number, and the certificate can be printed.

Serial No.	Time
61074406	02-10-2014 08:10:02
61074406	02-10-2014 08:11:52

## 14.6 Flow sensor adjustment

### 14.6.1 General information

Should it prove necessary, during verification, to adjust the flow sensor, this can be done by selecting “Flow Sensor Adjustment” from the menu. This function is password protected and a password can be obtained from Kamstrup A/S. Data connection between the PC and MULTICAL® 402 can be made either via program cable interface (see below) or verification equipment.

### 14.6.2 Interface

The following interfaces can be used:

type 66-99-108 Sub 9 Com port connector for PC and 10-pole connector for sensor

type 66-99-097 USB port connector for PC and 10-pole connector for sensor

**Note!** When the interface is connected the product/verification sealing of the meter is broken. Renewed test/verification as well as sealing is subsequently required (current handling and reverification requirements must be observed).

### 14.6.3 Application

Before adjusting a sensor you must make sure that the sensor functions satisfactorily in the flow stand in question.

If a sensor is to be adjusted more than a few per cent, the sensor is probably defective, or it is a different error, and therefore no adjustment should be made.

### 14.6.4 Flow sensor adjustment

Open “Flow sensor adjustment”:

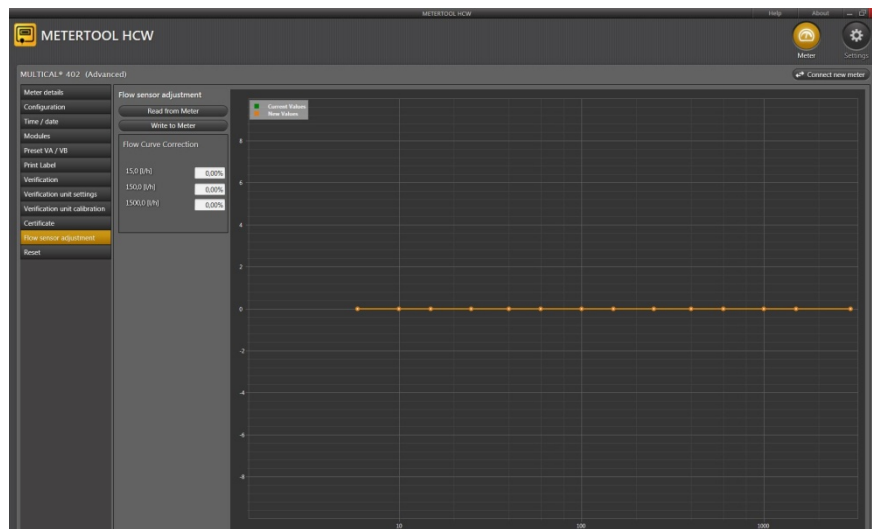

“Read from Meter”:

Reads data from flow sensor data

The required correction in  $q_i$ ,  $0.1xq_p$  and  $q_p$  can be entered in the field “Flow Curve Correction”.

“Write to Meter”:

Writes the correction to the connected flow sensor

Example: A MULTICAL®402 flow sensor shows the following result after verification:

1% of qp:	+1.1%
10% of qp:	+0.3%
100% of qp:	-0.1%

In order to correct the inaccuracies, the following values are entered:

1% of qp:	-1.1%
10% of qp:	-0.3%
100% of qp:	+0.1%

Adjustments of more than +/-5% ought not to be made, as they can be due to a flow sensor error.

Having been adjusted the flow sensor is now ready for test/verification as well as sealing.

**Note!** Current handling and reverification requirements must be observed.

## 14.7 LogView HCW

### 14.7.1 Introduction and installation

Regarding "Introduction", "Interface" and "Installation" see paragraph **14.1 Introduction METERTOOL HCW** since it is similar for LogView HCW.

### 14.7.2 General information

"LogView HCW" (ordering no. 6699-725) is used for read-out of logging data from MULTICAL® 402 calculator and top modules (e.g. hourly data) as well as interval logging. The read data can be used for analysis and diagnostic test of the heating installation. Data can be presented as table or graphics, tables can be exported to "Microsoft Office Excel".

For available logger data see paragraph 7.10 Data loggers.

### 14.7.3 "Log"

Select the required data function.

**Interval Data** allows interval reading of current MULTICAL® 402 counters at optional intervals between 1 and 1440 minutes as well as an optional number of repetitions of the reading from 1 to 9999 times.

For read-out of "current" counter values select interval 1 and repetition 1. Thereby one instantaneous reading is obtained.

**Daily Data, Monthly Data and Yearly Data** enable reading of logged data from MULTICAL® 402 including optional data period and values.

**Info Data** makes it possible to read out the latest 50 info events from MULTICAL® 402, the read-out includes date and info code of the info event.

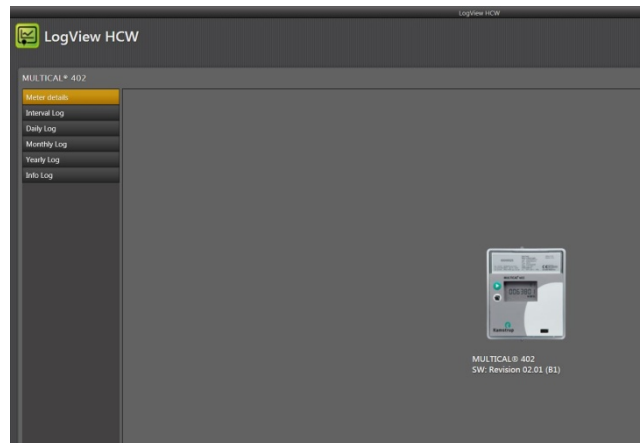

### 14.7.1 Help button

**Contact** The contact button gives you the links to Kamstrup's website and mailbox.

**Output** This function shows the latest functions used in the program.

**User manual** Links to the user manual for the meter on Kamstrup's website.

### 14.7.2 About button

Lists LogView's program version and revision numbers as well as all sub-programs, their type numbers and revision numbers for the entire LogView HCW program.

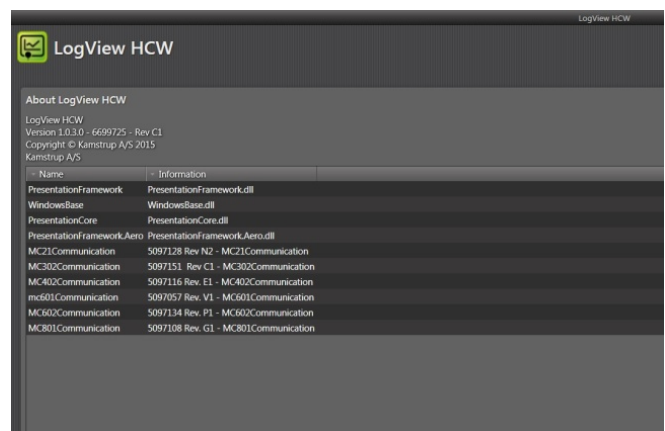

**14.7.3 Application**

Double-click on link or icon for "LogView HCW" in order to start the program and select the required data function.

**Meter identification!** Click "connect to meter"

"Daily Data" is used as an example:

The screenshot shows the LogView HCW interface for meter MULTICAL® 402. Callout boxes point to various features:

- Choice of data period from/to:** Points to the date selection fields (14/12/2015 to 14/12/2015).
- Activate "Read" to collect required data from the meter:** Points to the "Read" button.
- Or load already saved data values:** Points to the "Load" button.
- To save the read values into a file:** Points to the "Save" button.
- Export of read/loaded data to Excel spreadsheet:** Points to the "Export to Excel" button.
- Choice of Graph(s) or table presentation of data from read/loaded period:** Points to the "Graph" and "Table" toggle buttons.
- Choice of required data registers:** Points to the list of registers on the right side of the interface.

Select the required registers by clicking on the box next to the register name. To read out all data, activate "Select All" to select all values.

When read-out has been completed the read values can be saved by clicking "Save". We recommend to save the read-outs, securing that data can be reopened later for further analysis or documentation.

The values appear in graphs or list form by activating "Graph"/"Table" (toggle function).

In order to carry out a new data read-out, you just select a new period and new data registers. If the formerly read values have not already been saved you will be asked if you want to do so.

Tables can be exported direct to "Windows Office Excel" or printed.

To zoom in; activate Zoom and select the area you wish to zoom into. To zoom out; doubleclick anywhere on the coordinate system.

To read exact values on the graphs; deselect Zoom and let the mouse pointer "hover" over the point of interest.



## **15 Approvals**

### **15.1 Type approvals**

MULTICAL® 402 is type approved according to MID on the basis of pr EN 1434-4:2009.

MULTICAL® 402 has a national German cooling approval based on PTB K7.2.

### **15.2 The Measuring Instrument Directive**

MULTICAL® 402 is available with CE-marking according to MID (2004/22/EC). The certificates have the following numbers:

B-module: DK-0200-MI004-013

D-module: DK-0200-MIQA-001



## Declaration of Conformity

Overensstemmelseerklæring  
 Déclaration de conformité  
 Konformitätserklärung  
 Deklaracja Zgodności  
 Declaración de conformidad  
 Declarație de conformitate  
 Atbilstības deklarācija

We  
 Vi  
 Nous  
 Wir  
 My  
 Nosotros  
 Noi  
 Mēs

**Kamstrup A/S**  
**Industrivej 28, Stilling**  
**DK-8660 Skanderborg**  
**Denmark**  
**Tel: +45 89 93 10 00**

declare under our sole responsibility that the product(s):  
 erklærer under eneansvar, at produkt(erne):  
 déclarons sous notre responsabilité que le/les produit(s):  
 erklären in alleiniger Verantwortung, dass/die Produkt(e):  
 Deklarujemy z pełną odpowiedzialnością, że produkt(y):  
 Declaramos, bajo responsabilidad propia que el/los producto  
 declaram pe proprie raspundere ca produsul/produsele:  
 ar pilnu mūsu atbildību apliecinām, ka produkts(-i):

Instrument	Type	Type No.:	Classes	Type Approval Ref.:
Heat Meter	MULTICAL® 402	402-V, 402-W, 402-T		DK-0200-MI004-013
Heat Meter	MULTICAL® 302	302-T	CI 2/3, E1, M1, M2	DK-0200-MI004-031
Temperature Sensors	PL and DS	65-00-0A/B/C/D 66-00-0F/G 65-00-0L/M/N/P 66-00-0Q3/4 65-56-4	M1	DK-0200-MI004-002 DK-0200-MI004-036
Flow Sensor	ULTRAFLOW® qp 0.6...400 m3/h	65-S/R/T	CI 3, M1, E1	DK-0200-MI004-003
Flow Sensor	ULTRAFLOW® qp 0.6...40 m3/h and qp 150...400 m3/h	65-S/R/T	CI 2/3, M1, E1	DK-0200-MI004-003
Calculator	MULTICAL® 601 MULTICAL® 601+ MULTICAL® 602 MULTICAL® 6L2 SVM S6 MULTICAL® 801	67-A/B/C/D 67-E 602-A/B/C/D 6L2-F S6-A/B/C/D 67-F/G/K/L	M1, E1/E2 M1, E1/E2 M1, E1/E2 M1, E1/E2 M1, E1/E2 M1, E1/E2	DK-0200-MI004-004 DK-0200-MI004-004 DK-0200-MI004-020 DK-0200-MI004-020 DK-0200-MI004-020 DK-0200-MI004-009
Flow Sensor	ULTRAFLOW® 54/34 qp 0.6...100 m3/h qp 150...1000 m3/h ULTRAFLOW® 54	65-5/65-3 65-5	CI 2/3 M1, E1/E2 M1/M2, E1/E2 M1/M2, E1/E2	DK-0200-MI004-008 DK-0200-MI004-033
Water Meter	MULTICAL® 21 MULTICAL® 62 flowIQ® 2101 flowIQ® 3100	021 62-Z 021 031	CI 2, M1, E1/E2 CI 2, M1, E1, B CI 2, M1, E1/E2 CI 2, M1, E1/E2	DK-0200-MI001-015 DK-0200-MI001-016 DK-0200-MI001-015 DK-0200-MI001-017

are in conformity with the requirements of the following directives:

er i overensstemmelse med kravene i følgende direktiver:

sont conforme(s) aux exigences de la/des directives:

mit den Anforderungen der Richtlinie(n) konform ist/sind:

są zgodne z wymaganiami następujących dyrektyw:

es/son conformes con los requerimientos de las siguientes directivas:

este/sunt in conformitate cu cerintele urmatoarelor directive:

atbilst šādu direktīvu prasībām:

Measuring Instrument Directive 2004/22/EC, Module D  
 EMC Directive 2004/108/EC  
 LVD Directive 2006/95/EC  
 PE-Directive (Pressure) 97/23/EC, Module A1  
 R&TTE 1999/5/EC  
 RoHS II Directive 2011/65/EU

**Date: 2016/01/28**

**Sign.:**

Notified Body, Module D Certificate:  
 Force Certification A/S  
 EC Notified Body nr. 0200  
 Park Alle 345, 2605 Brøndby  
 Denmark

*Viggo Andersen*  
**Viggo Andersen**  
**Quality Assurance Manager**

5518-050, Rev.: AB1, Kamstrup A/S, DK8660 Skanderborg, Denmark

## 16 Troubleshooting

MULTICAL® 402 has been constructed with a view to quick and simple installation as well as long and reliable operation at the consumer.

Should you, however, experience an operating problem, the table below can be used for troubleshooting.

Repairing the meter, if needed, we recommend only to replace battery, temperature sensors and communication modules. Alternatively, the whole meter should be replaced.

Major repairs must be made by Kamstrup A/S.

Before sending us the meter to be repaired or checked, please use the error detection table below to help you clarify the possible cause of the problem.

Symptom	Possible reason	Proposal for correction
No display function (empty display)	Power supply missing	Change battery or check mains supply. -Does the supply plug provide 3.6 VDC?
No energy accumulation (e.g. MWh) and volume (m <sup>3</sup> )	Read "INFO" in the display	Check the error indicated by the info code (see paragraph 7.8)
	If "INFO" = 0 ⇒	Check that the flow direction matches the arrow on the flow sensor
	If "INFO" = 4, 8 or 12 ⇒	Check temperature sensors. If defective, replace the sensor set.
Accumulation of volume (m <sup>3</sup> ) but not of energy (e.g. MWh)	Flow and return sensors have been interchanged in either installation or connection	Mount the sensors correctly
	The heat/cooling cutoff $\theta_{hc}$ has been configured too low	Reconfigure $\theta_{hc}$ at a suitable value, or configure $\theta_{hc}$ at 180°C, thereby disconnecting the cutoff function
Incorrect temperature reading	Defective temperature sensor	Replace the sensor pair
	Insufficient installation	Check the installation
Temperature indication a little too low, or accumulation of energy (e.g. MWh) slightly too low	Bad thermic sensor contact	Place the sensors at the bottom of the sensor pockets
	Heat dissipation	Insulate sensor pockets
	Too short sensor pockets	Replace by longer pockets

## 17 Disposal

Kamstrup A/S holds an environmental certification according to ISO 14001, and as part of our environment policy we use materials which can be recovered environmentally correct to the greatest possible extent.

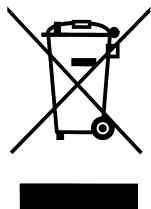

As from August 2005 Kamstrups heat meters are marked according to EU Directive 2002/96/EEC and the standard EN 50419.

The purpose of the marking is to inform our customers that the heat meter cannot be disposed of as ordinary waste.

### • Disposal

Kamstrup accept outworn MULTICAL® 402 for environmentally correct disposal according to previous agreement. The disposal arrangement is free of charge to the customer, except for the cost of transportation to Kamstrup A/S or the nearest disposal system.

The meters should be disassembled as described below and the separate parts handed in for approved destruction. The batteries must not be exposed to mechanical impact and the lead-in wires must not be short-circuited during transport.

Item	Material	Recommended disposal
2 x AA Lithium cells	Lithium and thionyl chloride 2 x AA-cells: About 2 x 0.7 g lithium	Approved deposit of lithium cells
D-cell lithium battery	Lithium and thionyl chloride >UN 3090< D-cell: About 4.5 g lithium	Approved deposit of lithium cells
PCBs in MULTICAL® 402 (remove LC-display)	Coppered epoxy laminate, components soldered on	PCB scrap for metal recovery
LC display	Glass and liquid crystals	Approved processing of LC-displays
Cables for flow sensor and sensors	Copper with silicone mantle	Cable recovery
Transparent top cover	PC	Plastic recycling or combustion
PCB case and connecting base	ABS with TPE gaskets	Plastic recycling or combustion
Wall bracket	PC + 20% glass	Plastic recycling or combustion
Meter case Clamp plate Transducer/reflectors	> 84% alpha brass/red brass < 15% common steel (St 37) < 1% stainless steel	Metal recovery
Packing	Environmental cardboard	Cardboard recycling
Packing	Polystyrene	EPS recovery

Please send any questions you may have regarding environmental matters to:

**Kamstrup A/S**  
 Att.: Quality and environmental dept.  
 Fax.: +45 89 93 10 01  
 info@kamstrup.dk

## 18 Documents

	<b>Danish</b>	<b>English</b>	<b>German</b>	<b>Russian</b>
Technical description	5512-741	5512-742	5512-743	5512-744
Data sheet	5810-724	5810-725	5810-726	5810-727
Installation and user's guide	5512-771	5512-772	5512-773	5512-774

