

Kamstrup 382

kWh meter 5(105)A with and without breaker

Measurement in 4 quadrants

Load profile in 4 quadrants

DLMS/COSEM compliant

Measurement in up to 8 tariffs

Voltage quality measurement

Safe data logging of consumption

Safe data logging of events

Immune to magnetic influence

Tamper detection

Real-time clock (RTC)

EN62056-21 Mode A



Type approved according to:

Active positive energy

EN 50470-1 (MID)

EN 50470-3 (MID)

Active negative energy and reactive energy

IEC 62052-11

IEC 62053-21

IEC 62053-23

Application

Kamstrup 382 is a direct connected electricity meter for registration of electric energy. The meter is full electronic without movable parts. Thus, shock and impact during transportation and mounting do not affect energy registration.

Furthermore, measurements are correct, no matter the physical mounting direction.

The shunt measuring principle gives good linearity, a considerable dynamic range, and ensures that the meter is not influenced by magnetism.

The easily readable display scrolls automatically between readings, or readings can be changed manually by the consumer activating a push button. The required display readings as well as their order are configurable.

In addition to being read from the display, data can be collected via the optical output or from the module area by means of a suitable communication module. The unique module area permits external changing of tariffs, pulse input and output, and configuration as well as connection of AMR and AMM modules.

Kamstrup 382J has DLMS/COSEM as standard. DLMS/COSEM is an open standardized protocol, which can be accessed by both the optical eye as well as a suitable communication module placed in the module area. This ensure that Kamstrup 382J is interchangeable with DLMS/COSEM compliant meter types from other producers.

From the factory, the meter can be configured to measure both imported and exported energy. As it is

constructed with three independent and galvanically separated measuring systems, the meter makes accurate measurements whether it measures on 1, 2, or 3 systems. The energy registration is saved in the integral data logger, which ensures good data history with its depth of 36.

As standard, all 382J meter types offer real time load profile generation for all 4 quadrants. The load profile provides detailed information about consumed or produced energy.

Kamstrup 382J offers smart disconnect functionality as well as prepayment as standard. Smart disconnect allows control of the internal relays based on exceeding a current/power limit.

The prepayment functionality uses a countdown register to control the internal breakers.

The meter is configurable and can be supplied from the factory with required functions. A minimum of handling during installation is thus secured.



Kamstrup

Kamstrup A/S
Industrivej 28, Stilling
DK-8660 Skanderborg
TEL: +45 89 93 10 00
FAX: +45 89 93 10 01
info@kamstrup.com
www.kamstrup.com

Functions

Meter types with and without breaker

Meter types without breaker:	382B, 382C, 382Jx1, 382Jx2, 382Jx3, 382Jx4, 382Jx5, 382Jx6, 382Jx7
Meter types with breaker:	382D, 382E, 382JxB, 382JxC, 382JxD, 382JxE, 382JxF, 382JxG

Display

The display is a liquid crystal display that makes it possible to read out the meter's registers. Available registers depend on the configuration.

The display configuration is constructed as 3 independent display lists. One for automatic shift function, one for manual shift function and one for battery supplied shift function. The display is constructed of segments as shown on the figure.

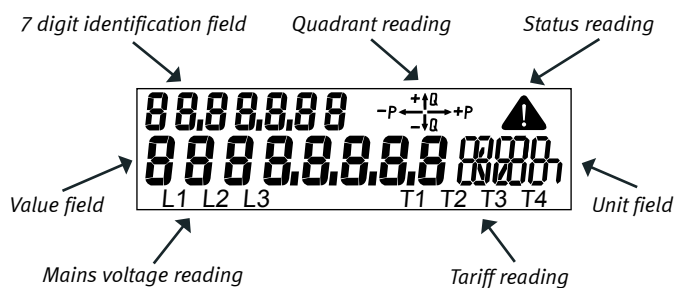

Value field

This field is used for displaying register values.

7 digit identification field

OBIS code identification of the value in the value field.

Quadrant reading

The actual active quadrant is indicated.

Status reading

Indication of critical internal errors and magnetic influence.

Unit field

This field is used for displaying the units of registers in the value field.

Tariff reading

Displays the active tariff, if tariffs is chosen.

Mains voltage reading

Indicates whether mains is connected above cut-off by either flashing or being permanently on for each individual phase. When flashing voltage is above cut-off but current is below cut-off.

The automatic shift function (scroll) changes between the selected readings in the required order every 10 sec. Historical data cannot be selected in the automatic shift function. Up to 16 readings can be selected.

Operation of the manual shift function is activated by pushing and releasing the push button. The order is optional, however it is not possible to opt out the legal readings. Up to 40 readings can be selected.

A battery operated shift function can be selected, which makes it possible to read the display without the meter being mains supplied. This require a battery backup. Activating the push button changes the reading. Up to 8 readings can be selected.

The meter automatically returns from manual shift function to automatic scroll function two min. after the last activation of the push button.

Energy measurement

The meter has one shunt per measuring system and resistance division for voltage measurement.

Like voltage drop, energy consumption is calculated as an expression of the current compared to the phase voltage and time.

The energy registration per measuring system is communicated to the meter's legal processor via the meter's internal bus system.

After correction the energies are summed in the main energy register.

Permanent memory

Measured and calculated data is safely stored in the memory (EEPROM). Data is stored by every change in energy register values.

Furthermore the below mentioned values are stored at the end of a debiting period.

Active energy A+
Active energy A-
Reactive energy R+
Reactive energy R-
Active energy A+ Tariff (T1-T4)
Reactive energy R+ Tariff (T1-T4)
Peak power P _{max} Tariff 1
Peak power P _{max} Tariff 1 Hour
Peak power P _{max} Tariff 1 Date
Peak power P _{max} Tariff 2
Peak power P _{max} Tariff 2 Hour
Peak power P _{max} Tariff 2 Date
Peak power P _{max}
Peak power P _{max} Date
Peak power P _{max} Hour
Accumulated peak power P _{max akk}
Date
Hour
Hour counter
Number of debiting periods
Power threshold counter
Pulse input

Optical reading

An optical infrared sender and receiver is placed on the front of the electricity meter to the left.

This optical reading can be used to read data or to configure e.g. display set-up and pulse figure.

By using METERTOOL for kWh meter, the meter's 3-display readings can be configured. Furthermore the integration period, target date for debiting logger and debiting logging interval can be changed.

Finally the pulse input on the meter can be scaled and tariffs can be changed.

It is not possible to change the meter's legal data without breaking the verification seal.

Functions

S0 pulse output

Emits pulses of active energy at 1000 pulses per kWh. The pulses are emitted synchronously with the LED.

The S0-output is specified according to the standard DIN 43864.

The maximum voltage, which may be connected to the S0 output, is 27 VDC (at 1 kΩ), and the maximum current, which may be drawn through the output, is 27 mA.

The pulse duration is 30 msec.

Plug-in modules

If needed, Kamstrup 382 can be extended by a plug-in module without subsequent reverification.

The module area communicates with the electricity meter's microprocessor via an internal data bus from the module area.

This provides innumerable functional possibilities, extra pulse output, tariff modules, power supply modules and data communication via GSM/GPRS, PLC, TCP/IP, radio or other medias.

Kamstrup 382 with radio

These meter types have build in radio communication on the electricity meter's main circuit board.

This is to optimise the product and eliminates the need for mounting the radio module subsequently.

When the meter's module area is used with an other type of communication, the integrated radio communication will be deactivated.

Kamstrup 382 with breaker

These meter types have build in disconnect function.

This means it is possible to disconnect the mains output from the electricity meter.

The disconnection can be done locally by using the meter's push button, automatically by either the smart disconnect or prepayment function, by METERTOOL for kWh meter or remotely by a connected reading system.

The disconnection must **NOT** be used as a safety switch.

The meter can be re-connected via the same media as it has been disconnected.

Load profile

Load profile is configurable to 5, 15, 30 or 60 minutes following the integration period.

The number of profiles generated follow the selected energy type of the meter.

Logging depth in days:

Minutes	5	15	30	60
A+	37	110	225	450
A+/A-	26	80	160	320
A+/A-/R+/R-	17	50	100	200

Approved measuring data

The meter is type approved according to the Measurement Instrument Directive (MID) for active positive energy and according to national requirements for other energy sizes where required.

Approval

Type test according to

– Active positive energy

– Reactive energy as well as active negative energy

Norm

EN 50470-1
EN 50470-3

IEC 62052-11
IEC 62053-21
IEC 62053-23

Approval

Terminal according to

S0 pulse output according to

Optical reading according to

OBIS codes according to

Norm

DIN 43857

DIN 43864

DLMS/cosem
and EN62056-21 Mode A

IEC 62056-61

Technical data

Measuring principle	
– Current	Single phased current measurement by current shunt
– Voltage	Single phased voltage measurement by voltage divider
Nominal voltage Un	3x230V ± 10% (only for Aron meter) 1x230V ± 10% 2x230/400V ± 10% 3x230/400V ± 10%
Current Ib(I _{max})	5(105)A 35 mm ² 10(60)A 10(85)A 5(85)A
Class	A B
Nominal frequency f _n	50/60 Hz ± 2%
Phase displacement	Unlimited, not for Aron meters however
Operating temperature	
– Without breaker	-40°C - +70°C
– With breaker	-40°C - +55°C
Storage temperature	-40°C - + 85°C
Protective class	IP52
Protection class	II
Relative humidity	< 75% year's average at 21°C < 95% less than 30 days/year, at 25°C

Weight

382 without breaker	382 with breaker
Approx. 680 g	Approx. 1200 g

Application area Indoors or outdoors in suitable meter cabinet

Internal consumption per phase.

Without breaker	
Current circuit	0.01 VA
Voltage circuit	0.5 VA, 0.2 W per phase at 3 phases

With breaker	
Current circuit	0.01 VA
Voltage circuit	0.7 VA, 0.45 W per phase at 3 phases

Material

- Cover Transparent polycarbonate
- Base Glass reinforced polycarbonate

Data storage EEPROM
> 10 years without voltage

Display

- LCD, 7mm-digit height (Value- and unit fields)
- LCD, 5mm-digit height (Identification readings)
- LCD, 3mm-digit height (voltage- and tariff-readings)

Meter constant 1000 imp./kWh,
1000 imp./kvarh

Real Time Clock (RTC)

Accuracy Typical 5 ppm at 23°C

Real time clock backup

- Battery life > 10 years at normal operation
- Supercap life > 10 years at normal operation

Supercap operating hours A week fully charged

S0-pulse diode 1000 imp./kWh, kvarh
Pulse duration 30 ms ±10%

S0-pulse output 1000 imp./kWh, kvarh
Pulse duration 30 ms ±10%

Short circuits level 4500 A²t

Connection modules

The meter can be supplied or retrofitted with the following inputs and outputs from main circuit board by connection modules, without reverification.

S0 Supply Sends 24 V via a two wire and pulses, by pulling down the supply at 0 V at each pulse.

Data/pulse Serial RS232 communication, open collector, 300/1200 baud. Maximum load (current).

Pulse value Imp/kWh, Imp/kvar	Pulse width/Pulse pause	
	30 msec	80 msec
1	105A	105A
10	105A	105A
100	105A	105A
1000	86A	32A
10000	8,6A	3,2A

M-Bus	Remote reading via M-Bus system.
2 tariffs	Tariff control via external 230 VAC.
Current Loop	Tariff control of 2 or 4 tariffs, CS and 230 VAC.
PLC	Remote reading via power line communication.
TCP/IP	Remote reading via TCP/IP communication.
GSM/GPRS	Remote reading via GSM/GPRS communication. Supports SMS reading.
Radio	Remote reading via radio communication. Build-in in 382CE, Jx4, Jx5, Jx6, Jx7, JxD, JxE, JxF, JxG

Connections

Main terminals

Elevating connections

Size	For use with connector type:		
	Multi core	7-core	Massive/cable end-sleeve
Brass terminal 35 mm ²	≥ 10 mm ²	≥ 10 mm ²	≥ 2.5 mm ²
Steel terminal 35 mm ²	≥ 6 mm ²	≥ 6 mm ²	≥ 1.5 mm ²
Steel terminal 25mm ²	≥ 6 mm ²	≥ 6 mm ²	≥ 1.5 mm ²

Screws PZ 2 and straight slot
Torque 2.5 – 3 Nm

Voltage outputs

Size	0.25 – 1.5 mm ² , 5 mm Cable terminal forks
Screws	TORX Tx 10 Torque 1Nm

Typical accuracy charts

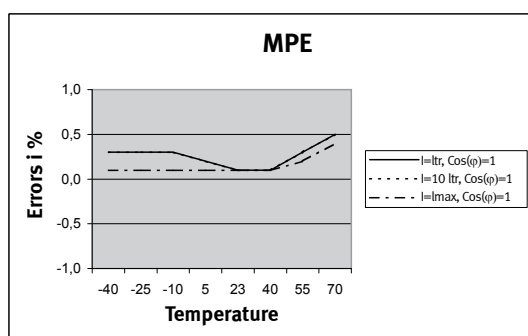
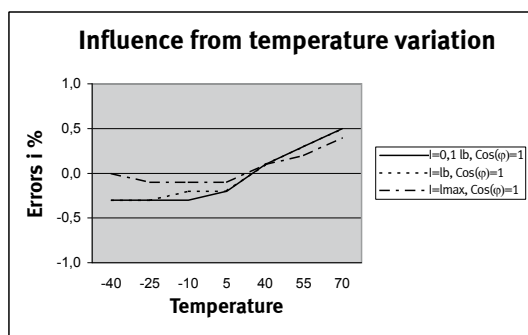
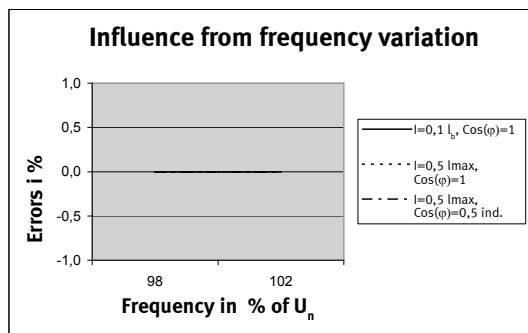
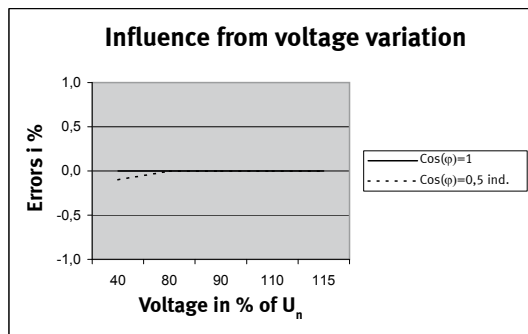
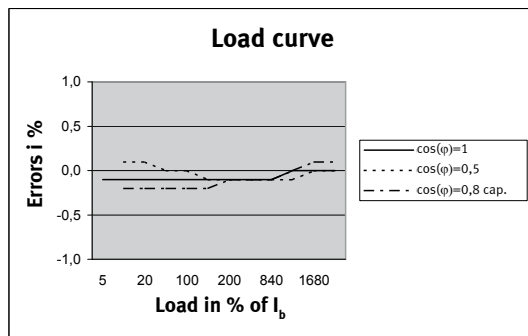

MPE (Maximum permissible error)

Composite error from:

- load
- Voltage variation
- frequency variation
- temperature variation

Ordering details

	684-	X ₁	X ₂	X ₃	X ₄	X ₅	X ₆	X ₇	X ₈	X ₉	X ₁₀
X₁ Phases											
3x230V		2									
3x230/400V		3									
X₂ Current											
0.25-5(105)A 35 mm ²			1								
0.25-5(65)A			4								
0.5-10(60)A			6								
0.5-10(85)A			7								
0.25-5(85)A			8								
X₃ Class											
Class A				A							
Class B				B							
X₄ Generation											
DLMS and load profile					J						
X₅ Energy type											
A+						1					
A+ / A-						2					
A+ / A- / R+ / R-						4					
X₆ HW option											
Basis							1				
RTC (Battery)							2				
RTC (Supercap)							3				
RF S incl. battery							4				
RF K incl. battery							5				
RF S incl. Supercap							6				
RF K incl. Supercap							7				
Breaker, battery, supercap							B				
Breaker, supercap							C				
Breaker, RF senea, supercap, battery							D				
Breaker, RF kamstrup, supercap, battery							E				
Breaker, RF senea, supercap							F				
Breaker, RF kamstrup, supercap							G				
X₇ Tariff configurable											
No tariff								1			
2-tariff								2			
Configurable								3			
4-tariff								4			
X₈, X₉, X₁₀ Country code											
DK											010
RUS											025
ES											031
NO											040
LV											045
LIT											049
GB											050
A											055
CH-I											059
EST											061
CH-D											063
PL											064
CH-F											065
ISL											067
DE											070
NL											080
FIN											084
SE											090

Configuration 1 (A-B-CCC-DD-E)

- A** Decimals displayed (locked)
- B** LED configuration (locked)
- CCC** Module
- DD** Input / output configuration
- E** Integration period

	A	B	C	C	C	D	D	E
A Decimals in display								
7.0	1							
6.1	2							
B LED configuration								
LED switched off without consumption		1						
LED switched on without consumption		2						
CCC Module								
No module, OK				000				
S0 Supply module, SK				001				
Data/pulse module, RK				003				
M-Bus module, MK				005				
Tariff module, 2 tariff, 230 V, WK				008				
Tariff module, 4 tariff, 230 V, CS, PK				018				
S0 Pulse module				021				
PLC module, router, ext. RTC				039				
IP101i, TCP/IP module				040				
Radio module, high power				043				
PLC module, S				050				
Radio module, router, S				052				
GSM6i				053				
GSM6i/RF				054				
S input/output				055				
DD Input/output configuration								
Contact Kamstrup							XX	
E integration period								
5 min.								1
15 min.								2
30 min.								3
60 min.								4

Configuration 2 (FFF-GG-HH-I)

- FFF** Display configuration – **Contact Kamstrup for further information.**
- GG** Target date
- HH** Debiting logging interval
- I** Various

Configuration 2 (FFF-GG-HH-I)

	G	G	H	H	I
GG Target date					
External controlled		00			
1.		01			
2.		02			
3.		03			
4.		04			
5.		05			
6.		06			
7.		07			
8.		08			
9.		09			
10.		10			
11.		11			
12.		12			
13.		13			
14.		14			
15.		15			
16.		16			
17.		17			
18.		18			
19.		19			
20.		20			
21.		21			
22.		22			
23.		23			
24.		24			
25.		25			
26.		26			
27.		27			
28.		28			
HH Debiting logging interval					
None (external controlled)				00	
Monthly				01	
Every second month, January				02	
Every second month, February				03	
Every third month, January				04	
Every third month, February				05	
Every third month, Marts				06	
Half-yearly, January				07	
Half-yearly, February				08	
Half-yearly, Marts				10	
Half-yearly, April				11	
Half-yearly, May				12	
Half-yearly, June				13	
Yearly, January				14	
Yearly, February				15	
Yearly, Marts				16	
Yearly, April				17	
Yearly, May				18	
Yearly, June				19	
Yearly, July				20	
Yearly, August				21	
Yearly, September				22	
Yearly, October				23	
Yearly, November				24	
Yearly, December				25	
I Various					
30ms, pulses					1
80ms, pulses					3

Configuration 3 (JJ-K-LL-M-NN)

- JJ** Disconnect setup
- K** Peak power
- LL** GMT
- M** Available
- NN** Unit pulse input

	J	J	K	L	L	M	N	N
JJ Disconnect setup								
None		00						
K Peak power								
Peak power standard			0					
Peak power for tariff 1			1					
Peak power for tariff 2			2					
LL GMT								
0 London					00			
1 DK-D-F-E					01			
2 FIN					02			
3					03			
4					04			
5					05			
6					06			
7					07			
8					08			
9					09			
10					10			
11					11			
12					12			
-11					13			
-10					14			
-9					15			
-8					16			
-7					17			
-6					18			
-5					19			
-4					20			
-3					21			
-2					22			
-1					23			
M Available								
None						0		
NN Unit pulse input								
None								00
kWh								01
m ³								02
L								03

Configuration 4 (OOO-PPP-QQ)

- OOO** Tariff control table / Holiday table / Table for summer/normal time plan
PPP Summer/normal time table
QQ Protocol

	O	O	O	P	P	P	Q	Q
OOO Tariff control table								
Contact Kamstrup			XXX					
PPP Summer/normal time table								
None						000		
001 EU						001		
QQ Protocol								
None								00

Configuration 5 (RRR)

- RRR** Frequency – transmitting power

	R	R	R
RRR Frequency – transmitting power			
Ingen radio			000
EU 310 RF S			310
EU 311 RF S			311
EU 312 RF S			312
EU 319 RF K			319
SE 320 RF S			320
SE 321 RF S			321
SE 322 RF S			322
SE 328 RF K			328
NO 330 RF S			330
NO 339 RF K			339
DK 340 RF S			340
DK 349 RF K			349

Installation

Connect the meter in accordance with the installation diagram on the meter's type label.

Connection diagrams

The valid connection diagram appears from the type label on the front of the meter.

3-phase, 4-wire

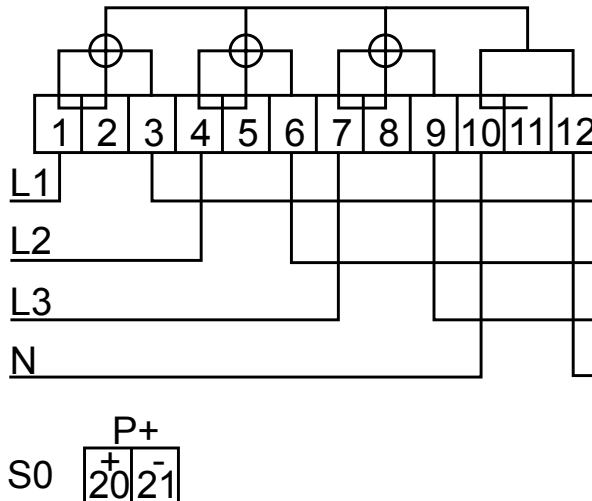

3-phase, 3-wire (Aron)

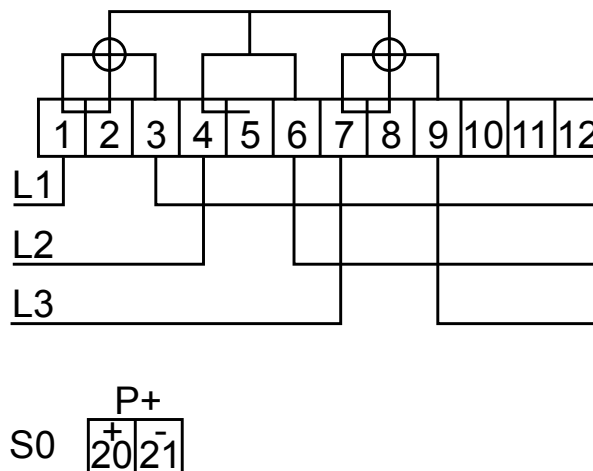

Security and installation guide lines

The meter shall only be used for measuring electrical energy and shall operate within the specified values only.

The meter must be switched off when working on it. It can be highly dangerous to touch the meter parts when the meter is switched on.

Therefore, the relevant safety fuse must be removed and kept in a place where unauthorised persons cannot insert it.

Current local standards, guidelines, regulations and instruction must be observed. Only authorised personnel are permitted to install electricity meters. Meters for direct connection must be protected against short circuit by a backup fuse in accordance with the maximum current stated on the meter.

The meter constant LED blinks proportionally to the consumed active energy.

Only authorised personnel must break the sealing.

Sealing

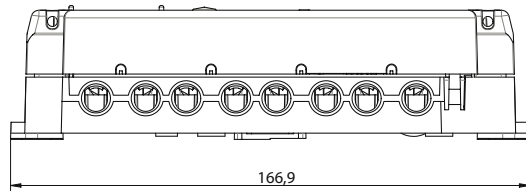

L
Phase indication
Lights individually, when
power is on the phase.

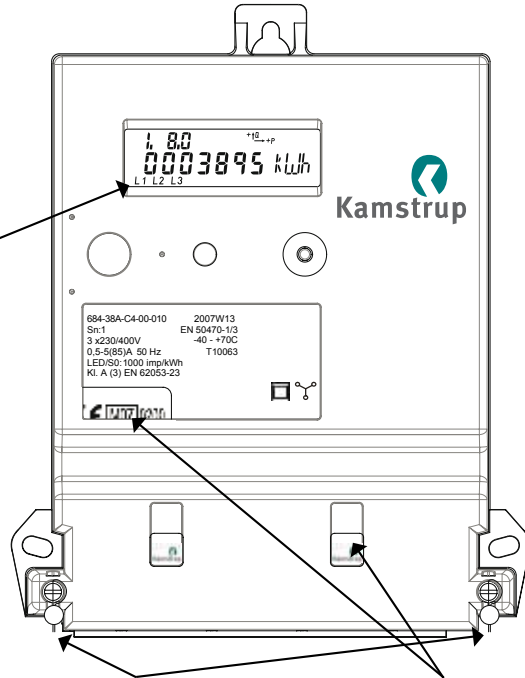

The electricity meter's connection terminals can be sealed in the usual way through the sealing screws and the meter's top cover.

The electricity meter is provided with verification sealings from the factory, which are visible through the top cover.

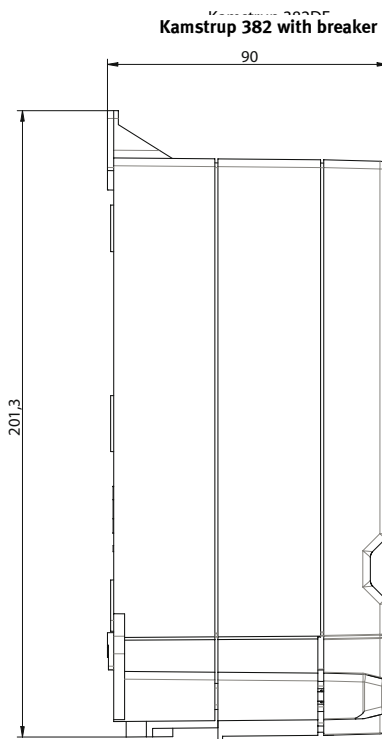
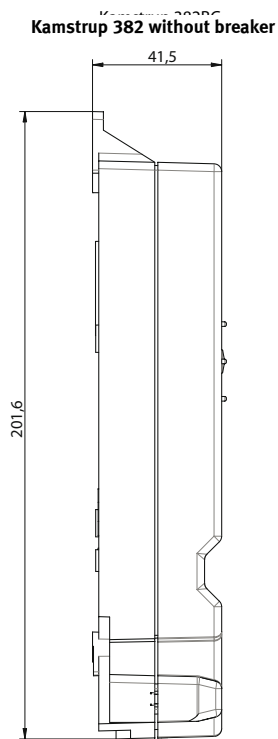

Accessories

Modules

S0 Supply module	SK	68 50 001
Data/pulse module, relay output	RK	68 50 003
M-Bus module	MK	68 50 005
Tariff module, 2 tariffs, 230 VAC	WK	68 50 008
Tariff module, 2 tariffs, 230 VAC, current loop	FK	68 50 014
Tariff module, 4 tariffs, 230 VAC, current loop	PK	68 50 018
S0 Pulse module		68 50 021
PLC module, router, external RTC	PO	68 50 039
IP101i, TCP/IP module	IK	68 50 040
Radio module, router, high power	QR	68 50 043
PLC S	PP	68 50 050
S RF router		68 50 052
GSMxi		68 50 053
GSM6i/RF		68 50 054
S input / output		68 50 055

Software

Configuration SW, METERTOOL for kWh meter		68 99 570
---	--	-----------

Various

Long terminal cover 60 mm		30 26 226
Extra long terminal cover 100 mm		30 26 323
Long terminal cover, meter with breaker		30 26 362
Optical reading head with 9-pole-t Dsub connector		66 99 102
Optical reading head with USB connector		66 99 099
DIN rail mounting		68 30 007
Extension for the top mounting ring		68 30 010
Top fitting, metal bow		68 50 101
Contact plugs, 50 pcs.		68 50 102
Cable terminals, 50 pcs.		68 50 103
Supercap for backup of RTC		68 30 012
Lithium battery for backup of RTC		68 30 013