

Technical description

## MULTICAL<sup>®</sup> 41 Water meter

---



  
**Kamstrup**

Kamstrup A/S  
Industrivej 28, Stilling  
DK-8660 Skanderborg  
TEL: +45 89 93 10 00  
FAX: +45 89 93 10 01  
info@kamstrup.com  
www.kamstrup.com



## List of contents

|          |   |           |
|----------|---|-----------|
| <b>1</b> | <b>General Description .....</b>                  | <b>5</b>  |
| 1.1      | Mechanical construction.....                      | 6         |
| <b>2</b> | <b>Technical Data .....</b>                       | <b>7</b>  |
| 2.1      | Approved meter data.....                          | 7         |
| 2.2      | Electrical data.....                              | 7         |
| 2.3      | Mechanical data.....                              | 7         |
| 2.4      | Accuracy.....                                     | 8         |
| 2.5      | Materials.....                                    | 8         |
| <b>3</b> | <b>Type Overview .....</b>                        | <b>9</b>  |
| 3.1      | Type number, MULTICAL® 41.....                    | 10        |
| 3.2      | PROG (A-B-CCC).....                               | 11        |
| 3.3      | CONFIG, DD-E-FF-GG.....                           | 12        |
| 3.4      | DATA.....   | 13        |
| 3.5      | Other functions.....                              | 13        |
| <b>4</b> | <b>Dimensional Sketches .....</b>                 | <b>14</b> |
| <b>5</b> | <b>Pressure Loss .....</b>                        | <b>15</b> |
| <b>6</b> | <b>Installation .....</b>                         | <b>16</b> |
| 6.1      | Installation requirements .....                   | 16        |
| 6.2      | Installation angle for MULTICAL® 41.....          | 17        |
| 6.3      | Straight inlet.....                               | 18        |
| 6.4      | Installation example.....                         | 18        |
| <b>7</b> | <b>The Calculator.....</b>                        | <b>19</b> |
| 7.1      | Measurement and calculation.....                  | 19        |
| 7.2      | Push buttons.....                                 | 19        |
| 7.3      | Display functions.....                            | 20        |
| 7.4      | Information codes.....                            | 21        |
| 7.5      | Reset functions.....                              | 22        |
| <b>8</b> | <b>The Flow Sensor.....</b>                       | <b>23</b> |
| 8.1      | Ultrasound with piezo-ceramics.....               | 23        |
| 8.2      | Principles.....                                   | 23        |
| 8.3      | The transit time method.....                      | 23        |
| 8.4      | Signal path.....                                  | 25        |
| 8.5      | Flow limits.....                                  | 25        |
| 8.6      | Guidelines for dimensioning the MULTICAL® 41..... | 25        |

**9 Supply Modules ..... 26**

9.1 Built-in D-cell lithium battery.....26

9.2 Supply module 230 VAC.....27

9.3 Supply module 24 VAC.....27

9.4 Exchanging the supply unit.....27

9.5 Mains supply cables.....28

**10 Plug-in Modules ..... 29**

10.1 Data/pulse inputs (66-0R).....29

10.2 M-Bus, EN 1434-3, EN 13757/pulse inputs (66-0P)  
M-Bus, EN 1434-3/ pulse inputs (66-0S).....30

10.3 Radio (66-0L).....31

10.4 Radio (66-0M).....32

**11 Data Communication ..... 33**

11.1 Optical reading.....33

11.2 Optical data reading.....33

11.3 Data strings.....34

11.4 Communication driver.....35

**12 Calibration and Verification ..... 36**

12.1 Testing mode.....37

12.2 Pulse Interface for MULTICAL® 41.....38

**13 Approvals ..... 39**

13.1 Type approvals .....39

13.2 CE-Marking.....39

13.3 Measuring instrument directive .....39

**14 Trouble Shooting..... 41**

**15 Disposal ..... 42**

**16 Documents ..... 43**

# 1 General Description

MULTICAL® 41 is a static **water meter** based on the ultrasonic principle. The water meter is based on experience gained since 1991 of development and production of static ultrasonic meters.

The meter, which is intended for measurement of water consumption in "utility room environments", has gone through a very extensive OIML R 49 type test to secure a long-term stable, accurate and reliable meter. Some of the many advantages of the water meter are among other things no wearing parts which improves the lifetime significantly. Furthermore, the meter has a start flow of just 3 l/h which gives accurate measurements also at low flow.

According to OIML R 49 the MULTICAL® 41 can be described as a "complete water meter". In practice this means, that flow sensor and calculation unit must not be separated.

If flow sensor and calculation unit have been separated and the seals thereby broken, the meter will no longer be valid for billing purposes, and the factory guarantee will not longer apply.

MULTICAL® 41 is based on ultrasonic measurement and a microprocessor technique. All circuits for calculation and flow measurement are gathered in a single-board construction providing a compact and rational design, and at the same time supreme measuring quality and reliability are achieved.

Volume measurement is carried out by means of bidirectional ultrasound technique according to the transit time method which is a long-term stable and accurate measuring principle. Through two ultrasonic transducers the sound signal is sent with and against the flow direction. The ultrasonic signal travelling in the flow direction will reach the opposite transducer first, and the time difference between the two signals can subsequently be converted into a flow velocity and thereby also a volume.

The accumulated water consumption is displayed in m<sup>3</sup> with seven significant digits and measuring unit. The display is specially constructed to obtain a long lifetime and high contrast in a wide temperature range.

Other possible display indications are operating hour counter and current flow. MULTICAL® 41 can also be configured to show peak flow, information code (info code), customer number and segment test.

MULTICAL® 41 is supplied from an internal lithium battery with a lifetime of up to 12 years. Alternatively, the meter can be mains supplied, either from 24 VAC or 230 VAC.

In addition to the water meter's own data, MULTICAL® 41 displays accumulated consumption for two extra meters that supply a contact signal to MULTICAL® 41 via a Reed switch. The contact signals from the extra meters are connected via the communication modules.

A multi-poled plug is placed under the top cover that is used partly for calibration and adjustment during verification and partly in connection with communication modules. MULTICAL® 41 is supplied with communication modules f.x. for radio, M-Bus and RS232.

1.1 Mechanical construction

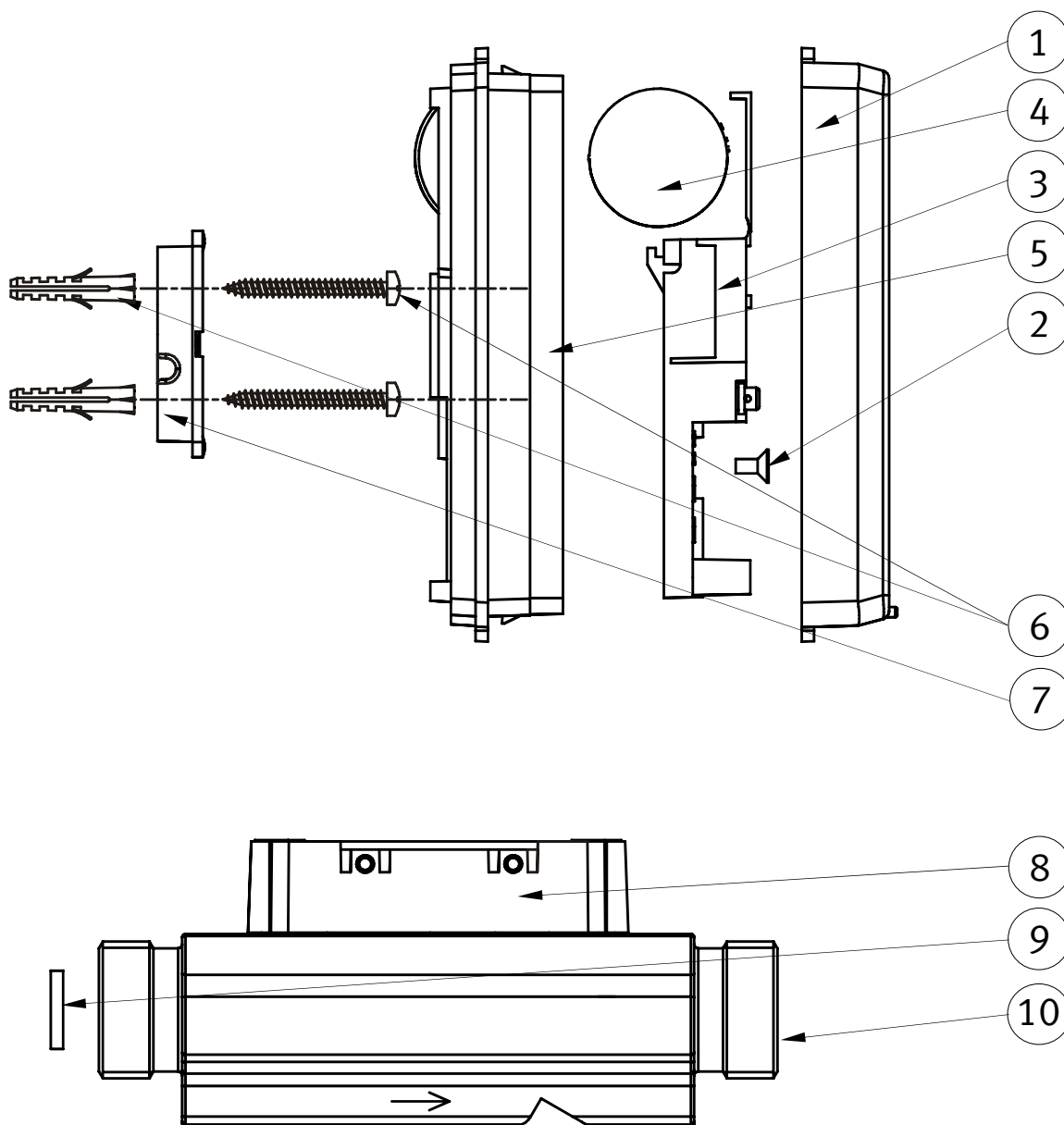

Figur 1

- 1 Transparent top cover with front plate
  - 2 Sealing screw for verification cover
  - 3 Verification cover including push button. The lid of the supply unit can be opened without breaking the verification
  - 4 Supply: Battery, 24 VAC or 230 VAC. Can be replaced without breaking the verification
  - 5 Case for electronics unit
  - 6 Screws and rawlplugs for brackets – wall mounting
  - 7 Brackets for wall mounting
  - 8 Meter case
  - 9 Strainer (accessory), see page 10
  - 10 Prepared for current check valves (NF EN 13959)
- } Always delivered with the meter (article no. 3130-105)

## 2 Technical Data

### 2.1 Approved meter data

OIML R 49 designation Accuracy class 2, environmental class B  
 Flow sensor types Q3 = 1.6 m<sup>3</sup>/h (see *Table 1*)  
 Media temperature in flow sensor 0.1°C....30°C

| <b>Type number</b>     | Nom. flow<br>[ m <sup>3</sup> /h ] | Max. flow<br>[ m <sup>3</sup> /h ] | Min. flow<br>[ l/h ] | Min. cut off<br>[ l/h ] | Pressure loss Δp @ Q3<br>[ bar ] | Connection to sensor            | Length<br>[ mm ] |
|------------------------|------------------------------------|------------------------------------|----------------------|-------------------------|----------------------------------|---------------------------------|------------------|
| 66-Zx-xx <b>5</b> -xxx | Q3=1.6                             | Q4=2.0                             | Q1=16                | 3                       | 0.28                             | G <sup>3</sup> / <sub>4</sub> B | 165              |
| 66-Zx-xx <b>9</b> -xxx | Q3=1.6                             | Q4=2.0                             | Q1=16                | 3                       | 0.28                             | G1B                             | 190              |

*Table 1*

### 2.2 Electrical data

Supply voltage 3.6 V ± 5%  
 Battery 3.65 VDC, D-cell lithium  
 Replacement interval 12 years @ t<sub>BAT</sub>< 30°C  
 Mains supply 230 VAC +15/-30%, 50 Hz  
 24 VAC ±50%  
 Power consumption mains supply < 1W  
 Backup mains supply Integral super cap eliminates operational disturbances due to short-term power cuts  
 EMC data Meets OIML R 49 class E1

### 2.3 Mechanical data

Metrological class 2  
 Environmental class Meets OIML R 49 class B  
 Electromagnetic environmental class Meets OIML R 49 class E1  
 Mechanical environment MID class M1  
 Ambient temperature 0...55°C  
 Protection class IP54  
 Medium temperature 0.1...30°C  
 Storage temperature, empty meter -25...60°C  
 Pressure stage (with thread) PN16  
 Flow sensor cable 1.4 m

## 2.4 Accuracy

MPE (Maximum Permissible Error).

MPE according to OIML R 49

± 5 % in the range  $Q_1 \leq Q \leq Q_2$

± 2 % in the range  $Q_2 \leq Q \leq Q_4$

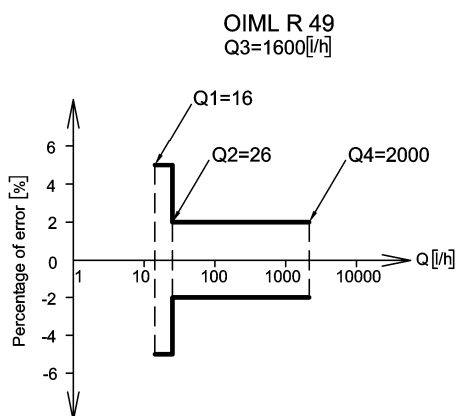

Diagram 1: OIML R 49 requirements to water meters

## 2.5 Materials

### Wetted parts

|                |                       |
|----------------|-----------------------|
| Housing, gland | Enkotal (alpha brass) |
| Transducer     | AISI 316              |
| Gaskets        | EPDM                  |
| Measuring pipe | PES 30% GF            |
| Reflectors     | AISI 304              |

### Flow sensor housing

|               |                |
|---------------|----------------|
| Wall/fittings | PC + 20% glass |
|---------------|----------------|

### Calculator housing

|                |  |
|----------------|--|
| Top            | PC   |
| Base           | ABS with TPE gaskets (thermoplastic elastomer) |
| Internal cover | PP   |

### Flow sensor cable

Silicone cable with internal teflon insulation

### 3 Type Overview

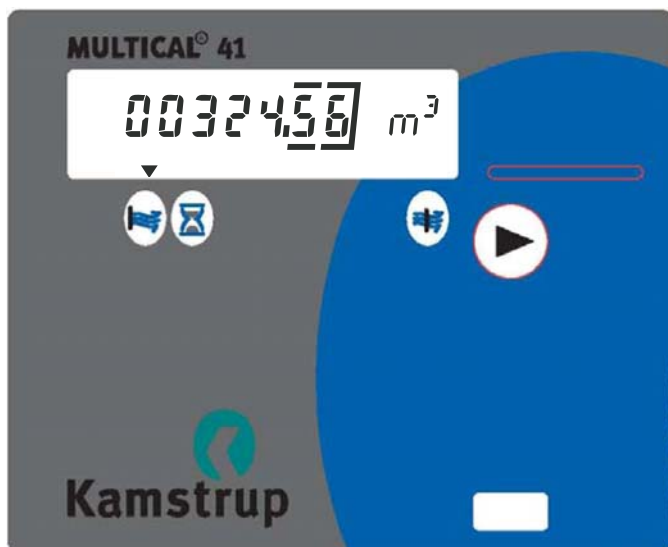

#### 3.1 Type number

66-Z?-??X-???

└── Flow sensor

The type number of the flow sensor cannot be changed after programming at the factory.

#### 3.2 PROG (total programming)

A-B-CCC

#### 3.3 CONFIG (partial programming)

DD-E-FF-GG

#### 3.4 DATA (partial programming)

- Customer no.
- Target date
- Peak average time
- - Date/time
- Telephone numbers
- Preset VA and VB

3.1 Type number, MULTICAL® 41

|   |                   |                    |   |   |   |   |     |
|---|-------------------|--------------------|---|---|---|---|-----|
|   | Type              | 66-Z               | □ | □ | 0 | □ | □□□ |
| <b>Modules</b>                                      |                   |                    |   |   |   |   |     |
| No module   |                   |                    | 0 |   |   |   |     |
| M-Bus/pulse inputs (secondary addressing)           |                   |                    | P |   |   |   |     |
| Data/pulse inputs                                   |                   |                    | R |   |   |   |     |
| M-Bus/pulse inputs (primary addressing)             |                   |                    | S |   |   |   |     |
| Radio/pulse output                                  |                   |                    | L |   |   |   |     |
| Radio with external antenna connection/pulse output |                   |                    | M |   |   |   |     |
| <b>Supply</b>                                       |                   |                    |   |   |   |   |     |
| No module   |                   |                    |   |   | 0 |   |     |
| Battery, D-cell                                     |                   |                    |   |   | 2 |   |     |
| 230 VAC supply module                               |                   |                    |   |   | 7 |   |     |
| 24 VAC supply module                                |                   |                    |   |   | 8 |   |     |
| <b>Flow sensor</b>                                  |                   |                    |   |   |   |   |     |
| <b>Q3 [m³/h]</b>                                    | <b>Connection</b> | <b>Length [mm]</b> |   |   |   |   |     |
| 1.6   | G¾B (R½)          | 165                |   |   |   | 5 |     |
| 1.6   | G1B (R¾)          | 190                |   |   |   | 9 |     |
| <b>Country code</b>                                 |                   |                    |   |   |   |   | 7XX |

In addition, the country code can be used for:

- Language and approval on type label
- Flow sensor dynamic range (1:100)
- Marking of PN class
- Special verification, if any

Customer labels (2001-XXX) are integrated into the front label.

3.1.1 Accessories

**Glands incl. gaskets**

- 6561-323 Gland incl. gasket for DN15, (R½ x G¾), two
- 6561-324 Gland incl. gasket for DN20, (R¾ x G1), two

**Gaskets**

Gasket for gland

- G¾ Type no. 2210-061
- G1 Type no. 2210-062

**Strainer for flow sensor inlet**

- 6556-484 Strainer DN15 for G¾B (R½), 10 strainers, not for 110 mm housing
- 6556-485 Strainer DN20 for G1B (R¾), 10 strainers

**Anti-pollution check valve (EN 13959) for flow sensor return, incl. PE gasket**

- 6556-480 Anti-pollution check valve DN15 for G¾B, incl. strainer and two PE gaskets, not for 110 mm housing ( PE = Polyethylene)
- 6556-481 Anti-pollution check valve DN20 for G1B, incl. strainer and two PE gaskets

**PE gasket for strainer and anti-pollution check valve**

- 6556-494 DN15 (10 gaskets)
- 6556-495 DN20 (10 gaskets)

### 3.2 PROG (A-B-CCC)

|                     |                                |   |                                |   |   |
|---------------------|--------------------------------|---|--------------------------------|---|---|
| Programming number  | A                              | - | B                              | - | CCC   |
|                     | <input type="text" value="3"/> |   | <input type="text" value="4"/> |   | <input type="text" value=""/> <input type="text" value=""/> <input type="text" value=""/> |
| Flow sensor placing | Internal value                 |   |                                |   |   |
| Measuring unit      | Internal value                 |   |                                |   |   |
| Flow sensor coding  |                                |   |                                |   | CCC   |

#### 3.2.1 Standard CCC-codes

| CCC-table for MULTICAL® 41 |                                   |  |  |    |     |  |  |              |                       |
|----------------------------|-----------------------------------|--|--|----|-----|--|--|--------------|-----------------------|
| CCC no.                    | Number of decimals on the display |  |  |    |     |  |  | Q3<br>[m³/h] | Type<br>66-Zx-xxX-xxx |
|                            |                                   |  |  | m³ | l/h |  |  |              |                       |
| 119                        |                                   |  |  | 2  | 0   |  |  | 1.6          | 5-9                   |

### 3.3 CONFIG, DD-E-FF-GG

#### 3.3.1 >DD< CONFIGURATION OF DISPLAY

**DD - codes >Primary<**

| Level 1  | 81  | 82  |  |  |
|--|-----|-----|--|--|
| Volume<br>Hour counter                                 | 1   | 1   |  |  |
|  | 2   | 2   |  |  |
|  |     |     |  |  |
|  |     |     |  |  |
| Actual flow<br>Peak flow (monthly)<br>Yearly peak flow | 3   | 3   |  |  |
|  | • 4 | • 4 |  |  |
|  |     |     |  |  |
| All info.<br>All info., however (-2)                   | 5   | 5   |  |  |

**DD - codes >Secondary<**

| Level A                         | 81 | 82 |  |  |
|---------------------------------|----|----|--|--|
| VA                              |    | A  |  |  |
| VB                              |    | B  |  |  |
| Reading date 1                  |    |    |  |  |
| Volume 1                        |    |    |  |  |
| Yearly peak flow 1              |    |    |  |  |
| Reading date 2                  |    |    |  |  |
| Volume 2                        |    |    |  |  |
| Yearly peak flow 2              |    |    |  |  |
| Monthly data 1-12               | A  | C  |  |  |
| Monthly volume                  | B  | D  |  |  |
| Monthly peak flow               | C  | E  |  |  |
|                                 |    |    |  |  |
|                                 |    |    |  |  |
| Prog no.<br>Customer no.        | D  | F  |  |  |
| Actual date<br>Software edition | E  | G  |  |  |
| Segment test                    | F  | H  |  |  |

- Selection of peak power or peak flow for monthly data (/#5), see 11.3

**NB: Info code 128 is automatically controlled in the factory/METERTOOL- configuration:**

Type 66-Zx-2xx-xxx ⇒ Info code 128 is **active**. In connection with other supply modules ⇒ Info code 128 is **not** active.

**NBB: Remember that replacing of battery for power supply requires reconfiguration of the type number.**

Yearly peak values are updated at the turn of the month.

3.3.2 >E< Configuration is not used for MULTICAL® 41

Set default at:

3.3.3 >FF< Input a, >GG< Input b, pulse separation ( $f \leq 0.5$  Hz)

| Input a<br>Terminal 65-66 |            | Input b<br>Terminal 67-68 |            | Pre-counter | l/pulse | Measuring unit and decimal point |          |
|---------------------------|------------|---------------------------|------------|-------------|---------|----------------------------------|----------|
| FF                        | Max. input | GG                        | Max. input |             |         |                                  |          |
| 00                        | OFF        | 00                        | OFF        | -           | -       | -                                | -        |
| 01                        | 50 m³/h    | 01                        | 50 m³/h    | 1           | 100     | m³a – m³b                        | 000000.0 |
| 02                        | 25 m³/h    | 02                        | 25 m³/h    | 2           | 50      | m³a – m³b                        | 000000.0 |
| 03                        | 12 m³/h    | 03                        | 12 m³/h    | 4           | 25      | m³a – m³b                        | 000000.0 |
| 04                        | 5 m³/h     | 04                        | 5 m³/h     | 10          | 10      | m³a – m³b                        | 000000.0 |
| 05                        | 2.5 m³/h   | 05                        | 2.5 m³/h   | 20          | 5.0     | m³a – m³b                        | 000000.0 |
| 06                        | 1 m³/h     | 06                        | 1 m³/h     | 40          | 2.5     | m³a – m³b                        | 000000.0 |
| 07                        | 0.5 m³/h   | 07                        | 0.5 m³/h   | 100         | 1.0     | m³a – m³b                        | 000000.0 |
| 24                        | 5 m³/h     | 24                        | 5 m³/h     | 1           | 10      | m³a – m³b                        | 00000.00 |
| 25                        | 2.5 m³/h   | 25                        | 2.5 m³/h   | 2           | 5.0     | m³a – m³b                        | 00000.00 |
| 26                        | 1 m³/h     | 26                        | 1 m³/h     | 4           | 2.5     | m³a – m³b                        | 00000.00 |
| 27                        | 0.5 m³/h   | 27                        | 0.5 m³/h   | 10          | 1.0     | m³a – m³b                        | 00000.00 |
| 40                        | 500 m³/h   | 40                        | 500 m³/h   | 1           | 1000    | m³a – m³b                        | 0000000  |

NB: Electricity meters cannot be connected as 1 sec. pulse and pause are required.

3.4 DATA

|                           | Automatic         | To be stated when ordering | Default            |
|---------------------------|-------------------|----------------------------|--------------------|
| Serial no. (S/N) and year | E.g. 2500000/2005 | -                          | -                  |
| Customer no.              | -                 | Up to 11 digits            | Customer no. = S/N |
| Target date               | -                 | MM=1-12 and DD=1-28        | 06.01 (1 June)     |
| TL2                       | -                 | -                          | 0                  |
| TL3                       | -                 | -                          | 0                  |
| Peak average time         | -                 | 1...120 min.               | 60 min.            |
| Date/time                 | YY.MM.DD/hh.mm.ss | -                          | -                  |
| Telephone number #1       | -                 | Max. 12                    | -                  |
| Telephone number #2       | -                 | Max. 12                    | -                  |

3.5 Other functions

When making orders in BOS, select "Locked M-Bus adr." and all meters in one order are made with the same customer number, e.g. 001. However, this requires customer label 2001-500 or higher.

### 4 Dimensional Sketches

#### MULTICAL® 41

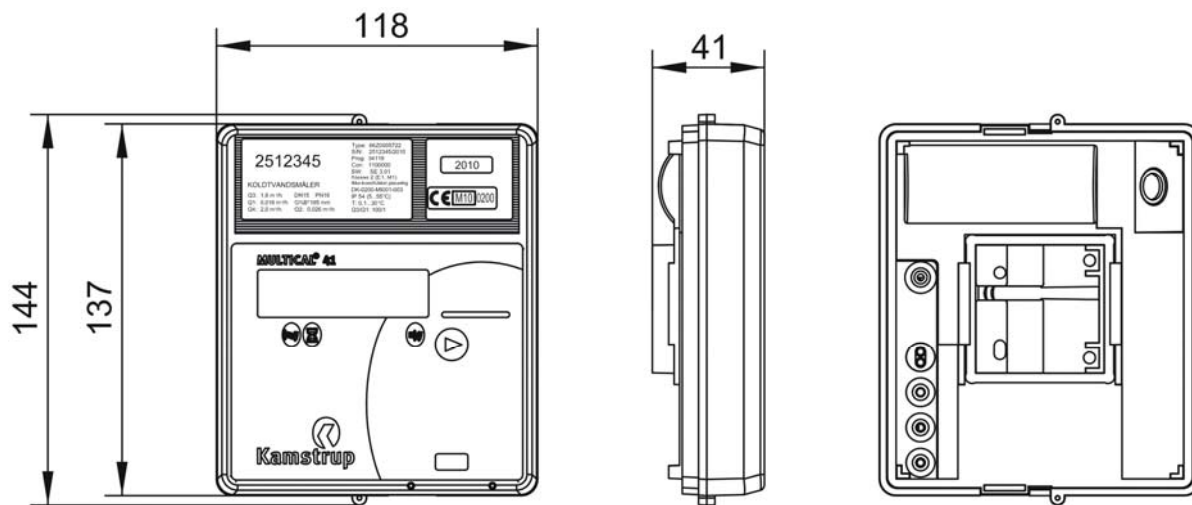

Figur 2: Mechanical dimensions of the electronic unit

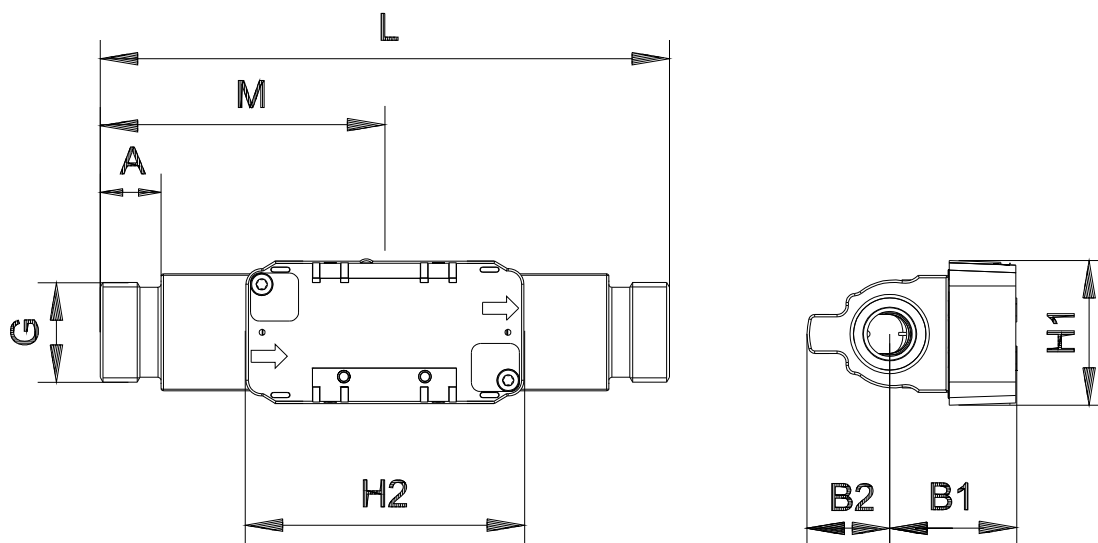

Figur 3: Flow sensor with G<sup>3</sup>/<sub>4</sub> and G1 thread connection

| Thread                                 | L   | M   | H2   | A    | B1 | B2 | H1   | Approx. weight [kg] |
|--|-----|-----|------|------|----|----|------|---------------------|
| G <sup>3</sup> / <sub>4</sub> (Q3=1.6) | 165 | L/2 | 92.5 | 20.5 | 42 | 28 | 47.5 | 1.7                 |
| G1 (Q3=1.6)                            | 190 | L/2 | 92.5 | 20.5 | 42 | 28 | 47.5 | 2.0                 |

Tabel 2: Total weight excluding packing

## 5 Pressure Loss

According to OIML R 49 the max. pressure loss must not exceed 1.0 bar in the range Q1 to Q4.

The pressure loss in a meter increases by the square of the flow and can be stated as:

$$Q = kv \times \sqrt{\Delta p}$$

where:

Q =volume flow rate [m³/h]

kv=volume flow rate at a pressure loss of 1 bar [m³/h]

Δp=pressure loss [bar]

| Graph | Q3<br>[m³/h] | Nom. diameter<br>[mm] | kv | Q@Δp 0.28 bar<br>[m³/h] |
|-------|--------------|-----------------------|----|-------------------------|
| A     | 1.6          | DN15 & DN20           | 3  | 1.6                     |

Tabel 3: Pressure loss table

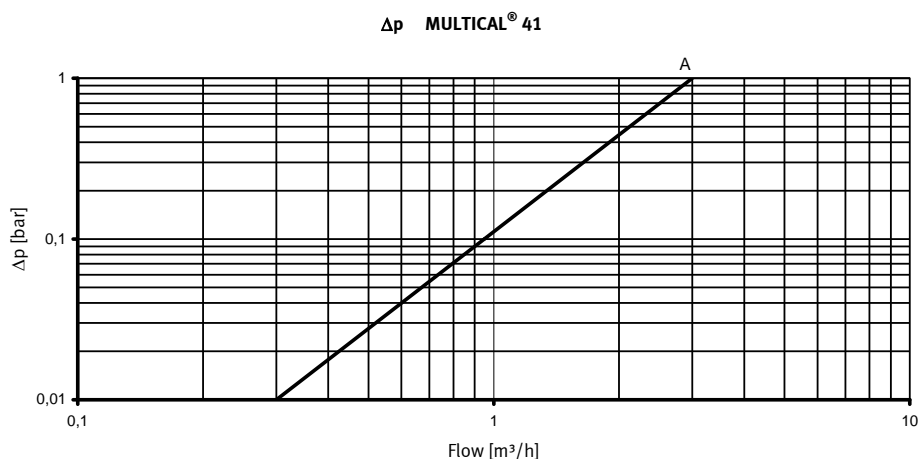

Diagram 2: Pressure loss graph

## 6 Installation

### 6.1 Installation requirements

Before mounting MULTICAL® 41, flush the system thoroughly with a fitting pipe mounted instead of the meter. Then remove the protection caps from the input and the output of the meter and mount the flow sensor with glands. Always use new packings in original quality.

In connection with mounting please make sure that the thread length of the glands does not prevent the sealing surface from being sufficiently tightened, and that NP10 glands are used (PN16 threads/glands can be used as well).

Correct position of the flow sensor. An arrow on the flow sensor indicates the flow direction.

The meter connection cables must be placed in such a way that condensed water cannot get into the meter.

#### Permitted operating conditions:

Ambient temperature: 0...55°C

Medium temperature: 0.1...30°C

System pressure: 1.5...16 bar (depending on gaskets/glands)

#### EMC conditions

MULTICAL® 41 is intended for installation in residential houses as well as in light industrial environments and the meter is CE marked according to OIML R 49 type test class E1 and the low-voltage directive.

Control cables from the meter must be drawn at a minimum distance of 25 cm from other installations.

#### Electrical installations

MULTICAL® 41 is available for both 24 VAC and 230 VAC mains supply. The mains connection is made with a 2 wire cable without earth connection.

Use a strong connection cable with an outside diameter of max. 7 mm and ensure that the meter has a correct cable retainer.

National regulations for electric installations must always be met, including e.g. a cable cross section used in relation to the fuse size of the installation (short-circuit current). Max. fuse 6 A.

For installations made in Denmark, the information from "Elråd" concerning "installations for mains supplied heat meters" applies to both direct 230 VAC supplied meters and 24 VAC meters supplied via a safety transformer.

#### Service

When the meter has been mounted in the system neither welding nor freezing is permitted. Dismount the meter from the system and disconnect the mains supply to the meter, if any, before the work is started.

To facilitate possible replacement of the meter, closing valves should always be mounted on both sides of the meter.

Under normal operating conditions no strainer is required on the front of the meter.

## 6.2 Installation angle for MULTICAL® 41

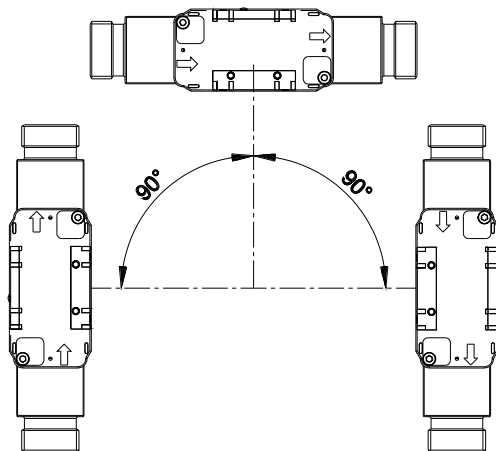

Figur 4

MULTICAL® 41 can be installed horizontally, vertically or at an angle.

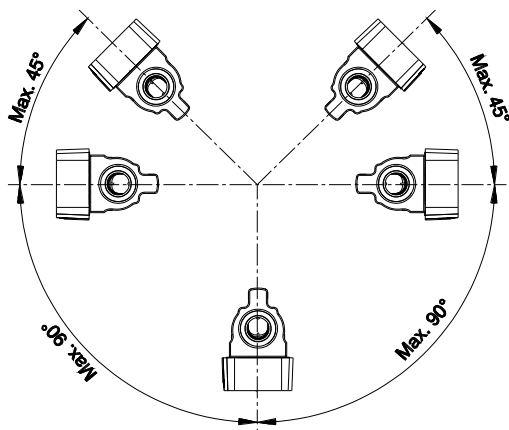

Figur 5

**Important!**

MULTICAL® 41 can be turned upwards to max. 45° and downwards to max. 90° in relation to the pipe axis.

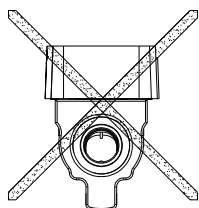

Figur 6

Do **not** turn the plastic housing upwards.

### 6.3 Straight inlet

MULTICAL<sup>®</sup> 41, DN15 (G<sup>3/4</sup>) and DN20 (G1): No requirements

### 6.4 Installation example

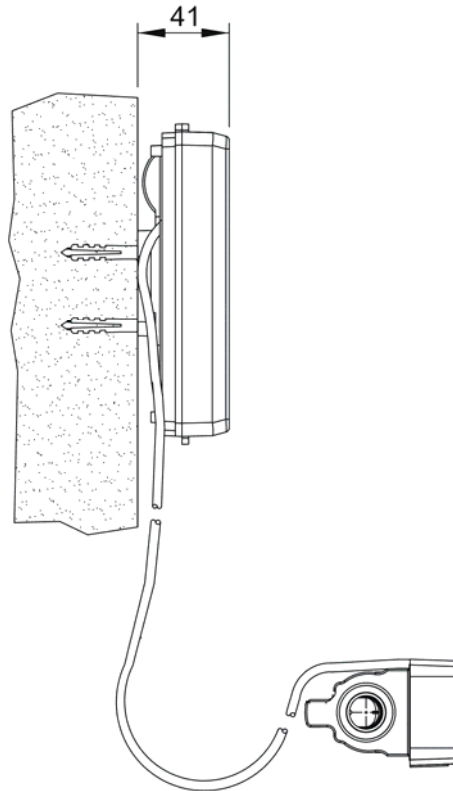

*Figur 7: Wall mounting of MULTICAL<sup>®</sup> 41*

## 7 The Calculator

### 7.1 Measurement and calculation

MULTICAL® 41 uses time based integration, i.e. calculations of accumulated volume are carried out at fixed intervals irrespective of the actual water flow. In normal mode MULTICAL® 41 has an integration interval of 28 sec., whereas in "fast mode" it has an interval of 4 sec.

#### "Normal mode"

In normal mode MULTICAL® 41 passes through an integration sequence of 28 sec. Through this sequence the water flow is measured at intervals of averagely 3.5 sec. All display values are updated at intervals of 28 sec. In addition, the display showing actual flow is updated at intervals of 14 sec.

#### "Fast mode"

In fast mode MULTICAL® 41 passes through an integration sequence of 4 sec. Through this sequence the water flow is measured at intervals of averagely 1 sec. At the end of the sequence the volume calculations are made.

All display values are updated at intervals of 4 sec.

### 7.2 Push buttons

MULTICAL® 41 has a **front key** for display change showing the **main menu** with **primary registers**. During normal operation the display shows the accumulated volume in m<sup>3</sup>.

By activating the front key the display e.g. shows actual flow, peak flow (monthly), hour counter etc. (see section 3.1.1 *Configuration of the display*).

If the front key is activated for 4 sec., the display changes to a **submenu** showing **secondary registers** such as Input A, Input B, tariffs and customer number (see section 3.1.1 *Configuration of the display*).

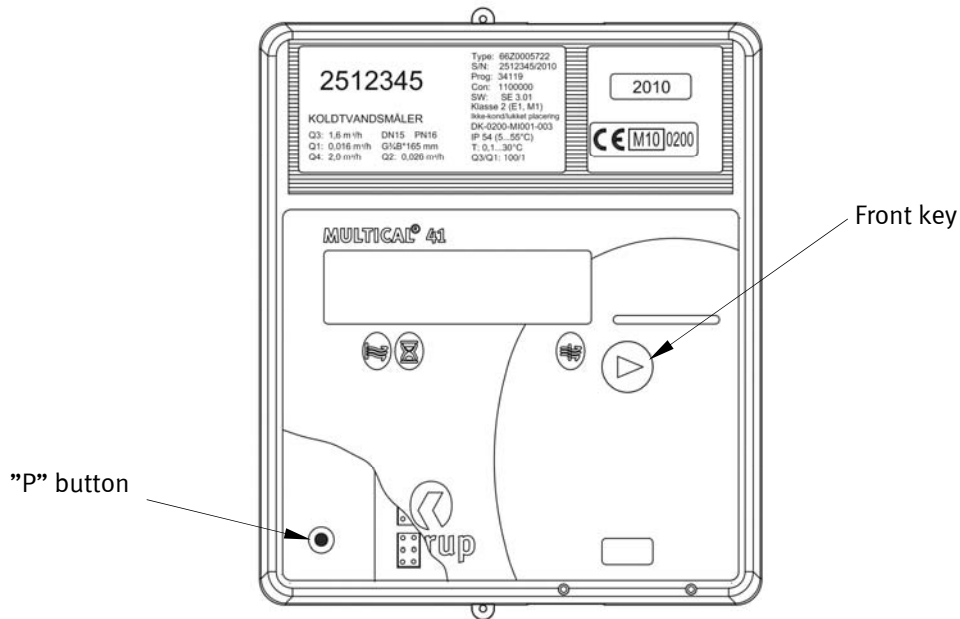

Figur 8

Under the transparent top cover an internal push button "P" is found. This button is used during verification of the meter (see section 12 *Calibration and verification*).

### 7.3 Display functions

No matter which display has been selected in the main menu or submenu, the display will automatically change into showing accumulated **volume**, when the front key has not been activated for 150 sec.

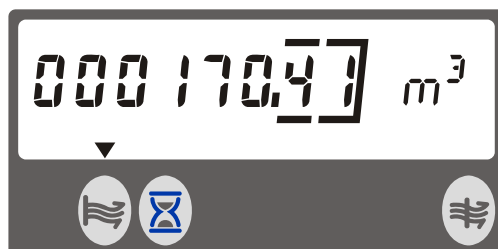

Figur 9

The contents of both main and submenus are determined by the configuration selected for the meter (see section 3.3.1 *Configuration of the display*). The display in MULTICAL® 41 includes both a main menu and a submenu. The main menu includes accumulated volume, flow readings, hour counter and info codes (error codes). When the front key is activated briefly, the display moves through the readings.

The submenu with **secondary registers** is activated by pressing the front key for 4 sec. Afterwards the front key can be used to move through the submenu readings. When the submenu has been selected, An "A" will appear in the left side of the display.



Figur 10

### 7.4 Information codes

MULTICAL® 41 is constantly checking a number of vital functions, whereby serious system errors can be detected. Should an error occur in the meter, the display will show and "E" in the left side. In case of short-duration errors the "E" will only be displayed as long as the error exists. If an error situation has existed for more than an hour, the information code becomes permanent and can now only be deleted by opening the meter (see 7.5 *Reset functions*).

When the first permanent information code occurs, it is stored in the EEPROM together with the date and volume registers at the time of the error.

The meter's actual "info code" appears as the last display reading in the main menu, i.e. when the front key has been activated 4 times depending on the selected display configuration. During normal operation the meter must show "000 info".



Figur 11

| Info               | Description  |
|--------------------|--|
| +000               | No errors found  |
| +016 <sup>1)</sup> | Air is detected in the flow sensor (is only indicated as long as the error exists)       |
| +128 <sup>2)</sup> | The battery must be replaced. This code occurs 12 years after the hour counter was reset |

Tabel 4

<sup>1)</sup> This information code may occur during transport and storage

During installation the info codes are reset as described in paragraph 7.5 *Reset functions*

<sup>2)</sup> Information code 128 is only active, where the meter is ordered with a battery (type number 66-Zx-2xx-xxx).

### 7.5 Reset functions

MULTICAL® 41 includes a “Power On Reset” circuit which is activated every time the supply voltage is switched on. This reset function only resets the internal high-resolution registers and therefore does not influence the display registers. After each ”Power On Reset” all registers are loaded from the EEPROM thereby ensuring that the meter always starts up with hourly data from the EEPROM.

When the “Power On Reset” function is combined with an activation of the front key or the internal verification button, the following reset functions are obtained:

| Action                                   | Function                    |
|--|-----------------------------|
| Reset + front key                        | Reset info                  |
| Reset + verification button (“P” button) | Reset info and hour counter |

Tabel 5

**Do not reset by short-circuiting the battery!**

“Power On Reset” is carried out by loosening one of the screw terminals 60(+) or 61(-). When the display goes out, reestablish the connection and at the same time activate the required push button combination.

Remember to fasten the screw terminals.

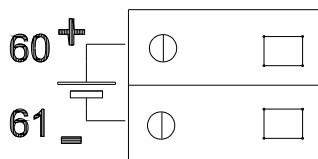

Figur 12

## 8 The Flow Sensor

### 8.1 Ultrasound with piezo-ceramics

Manufacturers of flow sensors have been working with alternative techniques to replace the mechanical principle. Research and development at Kamstrup have proven that ultrasonic metering is the most viable solution. Combined with microprocessor technology and piezo-ceramics, ultrasonic metering is not only accurate but also reliable.

### 8.2 Principles

The size of a piezo-ceramic element changes when exposed to an electrical field (voltage). When the element is influenced mechanically, an electric charge is generated. In this way the piezo-ceramic element can function both as a sender and as a receiver.

There are two main principles within ultrasonic flow metering: the transit time method and the Doppler method.

The Doppler method is based on the frequency shifting which is generated when sound is reflected from a moving particle. This is very similar to the effect you experience when a car drives by. The sound (frequency) is reduced, when the car passes by.

### 8.3 The transit time method

The transit time method used in MULTICAL® 41 utilizes the fact that an ultrasonic signal that is sent in the opposite direction of the flow, takes a longer time to travel from the sender to the receiver, than a signal travelling in the same direction as the flow.

The difference in transit time is very small in a flow sensor (nano-seconds). Therefore, the time difference is measured as a phase difference between the two 1 MHz sound signals to obtain the necessary accuracy.

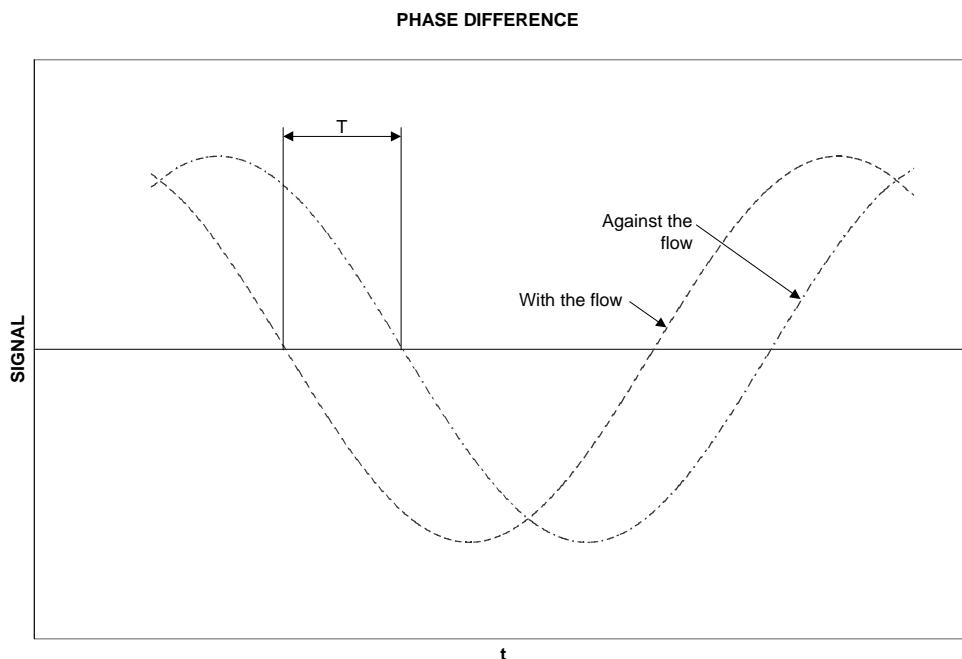

Diagram 3

In principle flow is obtained by measuring the flow velocity and multiplying it by the area of the measuring pipe:

$$Q = F \times A$$

where:

$Q$  is the flow

$F$  is the flow velocity

$A$  is the area of the measuring pipe

The area and the length that the signal travels in the sensor are well-know factors. The length with which the signal travels can be expressed as  $L = T \times V$  , and can also be stated as:

$$T = \frac{L}{V}$$

where:

$L$  is the measuring distance

$V$  is the sound radiation velocity

$T$  is the time

$$\Delta T = L \times \left( \frac{1}{V_1} - \frac{1}{V_2} \right)$$

In connection with ultrasonic flow sensors the velocities  $V_1$  and  $V_2$  can be stated as:

$$V_1 = C - F \text{ and } V_2 = C + F \text{ respectively}$$

where:  $C$  is the velocity of sound in water

By using above formula following is obtained:

$$\Delta T = L \times \frac{1}{C - F} - \frac{1}{C + F}$$

that can also be written as:

$$\Delta T = L \times \frac{(C + F) - (C - F)}{(C - F) \cdot (C + F)}$$

⇓

$$\Delta T = L \times \frac{2F}{C^2 - F^2}$$

As  $C \gg F$  it is possible to omit  $F^2$  and write the formula as:

$$F = \frac{\Delta T \times C^2}{L \times 2}$$

To minimise the influence from variations in the velocity of sound in the water, this is measured. Velocity of sound in water is measured by means of the built-in ASIC. For this purpose a number of absolute time measurements are made between the two transducers. These absolute time measurements are then converted into the current velocity of sound used in connection with the flow calculations.

### 8.4 Signal path

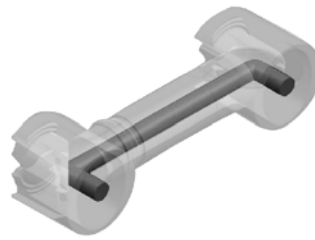

Q3: 1.6 m³/h

**Parallel**

The sound path is parallel to the measuring pipe and is sent from the transducers via reflectors.

### 8.5 Flow limits

In the meter’s working area from min. cut-off till far above Q4, there is a linear connection between the water volume flowing through and the water flow measured.

In practice the highest possible water flow through the meter will be limited by the pressure of the installation or by cavitation that has arisen as a consequence of a too low back pressure.

If the flow is lower than min. cut off or negative, MULTICAL® 41 will not measure any flow.

The upper flow limit Q4 is according to OIML R 49 the highest flow, at which the flow sensor must operate for short periods of time without exceeding the max. permissible error limit. During this period MULTICAL® 41 has no functional limitations when the meter operates over Q4. However, please note that high flow velocities >Q4 may cause cavitation, especially at low static pressures.

### 8.6 Guidelines for dimensioning the MULTICAL® 41

In connection with installations it is practical to work with pressures larger than the pressures state below:

| Nominal flow Q3 | Min. operating pressure [bar] | Max. flow Q4 [m³/h] | Min. operating pressure [bar] |
|-----------------|-------------------------------|---------------------|-------------------------------|
| 1.6             | 1.5                           | 2                   | 2.5                           |

Tabel 6

The purpose of recommended operating pressure is to avoid measuring errors as a result of cavitation or air in the water.

It is not necessarily cavitation in the sensor itself, but also bubbles from cavitating pumps or adjusting valves mounted before the sensor.

In addition, the water may contain air in the form of small bubbles or air in the water.

The risk of these factors affecting the accuracy is reduced by maintaining a fair pressure in the installation.

Furthermore, it must be taken into consideration that the mentioned pressure is the pressure at the sensor, and that the pressure is lower after a contraction than before (among other things due to cones). This means that the pressure – when measured elsewhere in the installation – might be different from the pressure at the sensor.

This can be explained by combining the continuity equation and Bernoulli’s equation. The total energy from the flow is the same at any cross section. For simplification, it can be written as :  $P + \frac{1}{2} \rho v^2 = \text{constant}$ .

When dimensioning the flow sensor above must be taken into consideration, especially if the sensor is used within the scope of OIML R 49 between Q3 and Q4 and in case of severe contractions in the pipe.



### 9.2 Supply module 230 VAC

This print module is galvanically separated from the mains supply and is suitable for direct mains installation. The module includes a double-chamber safety transformer that fulfils the requirements of double-insulation. The power consumption is less than 1 VA/1 W.



Figur 14

National installation requirements must be met. The 230 VAC module must only be connected by authorised personnel. In Denmark "Elråd nr. 5/98" or later edition must be followed. Max. fuse 6 A.

Changes from battery to mains supply require a re-programming, as info code 128 would otherwise still be active for the mains supplied meters.

### 9.3 Supply Module 24 VAC

The water meter is available with a print module which reduces the input voltage to approx. 3.6 VDC. The module has a built-in transient protection, but includes no galvanic separation between input and output voltages. The module is especially suited for installation together with a galvanically separated transformer, e.g. type 66-99-403

that can be installed in the switch cabinet. When the transformer is used, the power consumption will be less than 4 VA/1.5 W for the entire meter.



Figur 15

Changes from battery to mains supply require a re-programming, as info code 128 would otherwise still be active for the mains supplied meters.

### 9.4 Exchanging the supply unit

The supply unit for MULTICAL® 41 can be exchanged from mains supply to battery or vice versa as the needs of the utility company change. Thus, mains supplied meters can be exchanged into battery meters with advantage in connection with buildings under construction, as mains supply may be unstable or may even lack in periods.

In connection with an exchange it is, however, important to note that info code 128 (*Battery must be exchanged. The code is set 12 years after resetting the hour counter*) is only active at type number 66-Zx-2x-xxx.

## 9.5 Mains supply cables

MULTICAL<sup>®</sup> 41 is available with mains supply cables for either 24 V or 230 V (l=1.5 m):

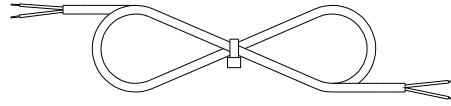

*Figur 16*

Supply cable, type 5000-286 (2 x 0.75 mm<sup>2</sup>), max. 6 A fuse

## 10 Plug-in Modules

| Modules   | Type | 66-Z |  |  |  |  |  |
|---|------|------|--|--|--|--|--|
| No module   |      |      |  |  |  |  |  |
| M-Bus/pulse inputs (secondary addressing)           |      | O    |  |  |  |  |  |
| Data/pulse inputs                                   |      | P    |  |  |  |  |  |
| M-Bus/pulse inputs (primary addressing)             |      | R    |  |  |  |  |  |
| Radio/pulse output                                  |      | S    |  |  |  |  |  |
| Radio with external antenna connection/pulse output |      | L    |  |  |  |  |  |
|   |      | M    |  |  |  |  |  |

### 10.1 Data/pulse inputs (66-0R)

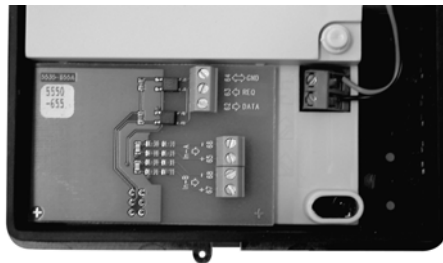

Figur 17

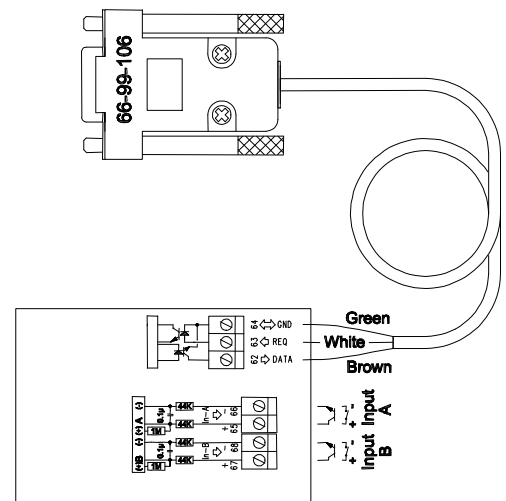

Figur 18

The module includes a data connection which e.g. can be used for external data plug designed for use with the hand-held terminal MULTITERM or as a semi-permanent PC connection.

The data connection is galvanically isolated by opto-couplers and therefore a data cable type 66-99-105 or type 66-99-106 to adjust the signal to RS-232 level is used for PC and MULTITERM.

2 additional pulse transmitters can be connected to the module, e.g. from cold and hot water meters. Meters with both Reed switch and transistor output can be connected. The inputs have a max. input frequency of  $\leq 0.5$  Hz.

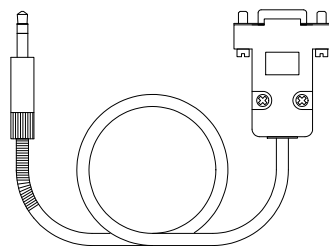

Figur 19

Type number 66-99-105

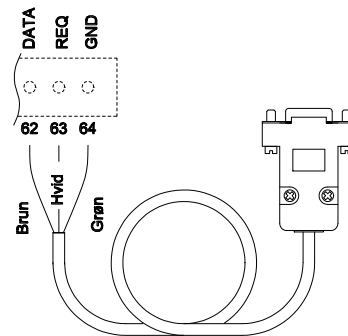

Figur 20

Type number 66-99-106

Reed switches with built-in protective resistances of up to 1 kOhm can be used, and both Input A and Input B contain the necessary de-bouncing for Reed switches.

No Darlington transistors should be used when connecting transistor outputs to Input A and Input B as the voltage level at the logical "0" must be < 0.5 V. In addition, the leak current in the output must be less than 1 µA.

The pulse inputs can be configured for most water meters.

See section 3.3.3 >FF< Input a, >GG< Input b for information on configuration of pulse values and maximum flow rate. Required configuration must be stated when ordering.

**10.2 M-Bus, EN 1434-3, EN 13757/pulse inputs (66-0P)  
M-Bus, EN 1434-3/pulse inputs (66-0S)**

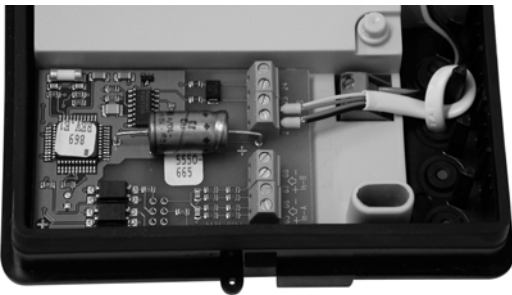

Figur 21

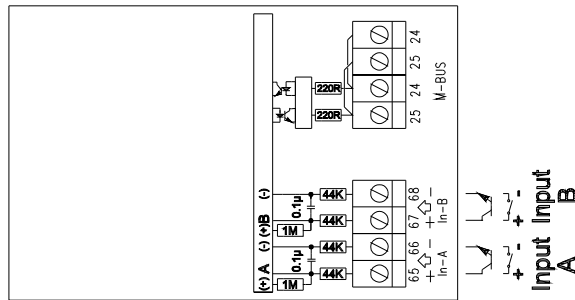

Figure 22

The M-Bus module is used for remote reading of MULTICAL® 41 via an M-Bus network.

To make an M-Bus system work each M-Bus Slave must have a unique address. The M-Bus address is automatically generated from the meter's customer number at start-up, and can easily be changed by means of the hand-held terminal MULTITERM.

The M-Bus module has 2 sets of parallel M-Bus terminals marked 24 and 25, to which the M-Bus is connected. The M-Bus connection is independent of polarity.

The M-Bus module is galvanically separated from the meter and is supplied via the M-Bus.

Each M-Bus module has a power consumption of 1.5 mA (1 Unit Load)

The data transmission speeds are 300 or 2400 baud, and the M-Bus module has a built-in autodetection of the baud rate.

The pulse inputs on this module are identical with the ones described earlier.

The Kamstrup M-Bus system is designed to meet the demands of the EN 1434-3 standard.

For further information, see Technical Description for Kamstrup's M-Bus system, 5511-709.

### 10.3 Radio (66-0L)

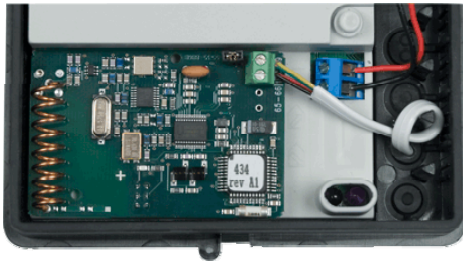

Figure 23

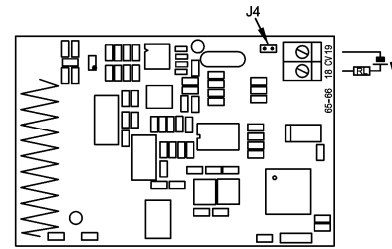

Figure 24

The radio module is used for wireless reading of MULTICAL® 41.

When connecting the supply voltage the radio module retrieves the type and meter number of the meter and transfers data to the memory of the module.

The radio module is ready to communicate in less than 10 seconds.

As standard the radio module is supplied with an internal antenna.

The radio module is read via the hand-held terminal, but is prepared to form part of a radio network.

The radio system is designed to meet the requirements of the EN 300 220 and EN 301 489 standards as well as in the R&TTE directive (**R**adio & **T**ele **T**erminal **E**quipment).

For further information, see Technical Description 5512-012.

The radio module also offers the option of leak surveillance. Every hour the meter's volume is checked and compared to an alarm limit.

If the limit is exceeded, the radio module sends an alarm to a radio network which handles the leak alarm.

The alarm limit is factory preset to 10 litres.

Furthermore, the module is mounted with a pulse output. The pulse output, which emits one pulse per 10 litres, is intended for CTS-systems.

Power: 30 V

Load: 10 mA

Pulse duration: 0.1 seconds

The pulse output is not active when delivered from Kamstrup.

The jumper J4 must be removed in order to activate the pulse output.

### 10.4 Radio (66-0M)

Radio module with connection plug for external antenna to increase the range.

Remaining functions are identical with the ones described earlier.

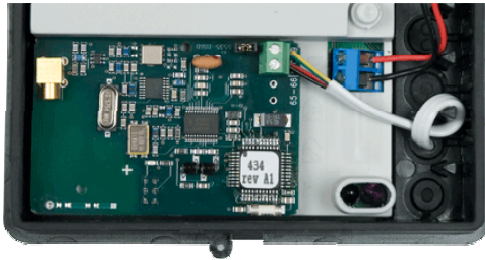

Figure 25

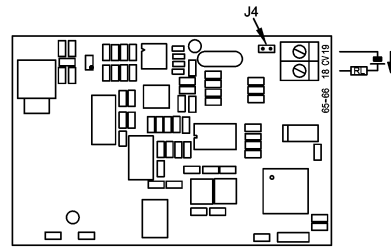

Figure 26

# 11 Data Communication

## 11.1 Optical reading

An optical, infrared transmitter/receiver is placed on the front of MULTICAL® 41. The data format fulfils IEC 870 in start mode and can then be converted into a producer specific format. A standardized optical reading head with a permanent magnet is used for data reading and configuration. To be able to change such data, however, an internal connection must be made before programming as the data in question is legal measuring data. If necessary, use data cable 66-99-108 or Verification Equipment 66-99-385, in which the internal connection is integrated. Kamstrup reading head, type 66-99-102 connects to Kamstrup’s hand-held terminal, MULTITERM, and a standard IBM compatible PC with Windows 98 or newer versions.

For further information on functions in the hand-held terminal and programming software, please refer to documentation for:

MULTITERM Pro

### Functioning

When the connected reading unit, MULTITERM, or the PC sends a recognizable request string, MULTICAL® 41 replies with a data string 1-2 sec. after having received the request string. MULTICAL® 41’s optical data reading uses the following communication setup:

300/1200 Baud, 1 Startbit, 7 Databits, Even parity, 2 Stopbits

NB: Except for optical reading, section 11.2, the other data strings contain neither measuring units nor decimal points (raw data). Information on decimal points is available on the CCC tables in this technical description.

## 11.2 Optical data reading

Below data can be read via the optical eye placed on the front of MULTICAL® 41 and via the data terminals.

| Command (300 BAUD)                  | Return string (300 BAUD)  |
|-------------------------------------|---|
| /?! [CR] [LF]<br>[ACK]000 [CR] [LF] | /KAM [0] MCC [CR] [LF]<br>[STX]0.0(11 digit K/N)<br>6.8(Blank)<br>6.26(Volume * m3)<br>6.31(Operating hours * h) ! [CR] [LF] [ETX]<br>[BCC] |

Tabel 8

In general, the reading is built up according to EN61107/IEC1107, Mode A, but BCC is calculated arithmetically as on M-Bus and not as module 2-binary sum according to ISO1155.

### 11.3 Data strings

Below data strings are compatible with the corresponding data strings in MULTICAL® Compact, MULTICAL® III, and MULTICAL® 66-CDE. The data strings are read via an optical reading head or via the data terminals on the plug-in modules.

Please note that 300 baud is used at request and 1200 baud at data.

For analytical purposes of /#5 monthly data, we recommend Kamstrup software METERTOOL LogView, type 66-99-703.

| Req | STANDARD DATA 1 |         |                 |         |         |         |         |         |                  |         |
|-----|-----------------|---------|-----------------|---------|---------|---------|---------|---------|------------------|---------|
| /#1 | Blank           | Volume  | Operating hours | Blank   | Blank   | Blank   | Blank   | Flow    | Peak flow actual | Info    |
|     | 7 ascii         | 7 ascii | 7 ascii         | 7 ascii | 7 ascii | 7 ascii | 7 ascii | 7 ascii | 7 ascii          | 7 ascii |

| Req | STANDARD DATA 2 |         |         |         |         |         |         |         |         |         |
|-----|-----------------|---------|---------|---------|---------|---------|---------|---------|---------|---------|
| /#2 | Customer no.    | Blank   | Blank   | Blank   | Blank   | In-A    | In-B    | ABCCC   | DDEFFGG | Date    |
|     | 11 ascii        | 7 ascii | 7 ascii | 7 ascii | 7 ascii | 7 ascii | 7 ascii | 7 ascii | 7 ascii | 7 ascii |

| Req | TARGET DATA  |             |         |         |         |         |         |         |                |  |
|-----|--------------|-------------|---------|---------|---------|---------|---------|---------|----------------|--|
| /#3 | Customer no. | Reading day | Blank   | Volume  | Blank   | Blank   | In-A    | In-B    | Peak flow year |  |
|     | 11 ascii     | 7 ascii     | 7 ascii | 7 ascii | 7 ascii | 7 ascii | 7 ascii | 7 ascii | 7 ascii        |  |

| Req            | MONTHLY DATA |              |         |         |         |         |         |         |                  |         |
|----------------|--------------|--------------|---------|---------|---------|---------|---------|---------|------------------|---------|
| /#5            | Customer no. | Reading date | Blank   | Volume  | Blank   | Blank   | In-A    | In-B    | Peak flow actual |         |
|                |              | Reading date | Blank   | Volume  | Blank   | Blank   | In-A    | In-B    | Peak flow        |         |
| 25 months back |              |              |         |         |         |         |         |         |                  |         |
| 26 Blank       |              |              |         |         |         |         |         |         |                  |         |
| 27 Blank       |              |              |         |         |         |         |         |         |                  |         |
| 29 Blank       |              |              |         |         |         |         |         |         |                  |         |
| 30 Blank       |              |              |         |         |         |         |         |         |                  |         |
| 31 Blank       |              |              |         |         |         |         |         |         |                  |         |
|                | 11 ascii     | 7 ascii      | 7 ascii | 7 ascii | 7 ascii | 7 ascii | 7 ascii | 7 ascii | 7 ascii          | 7 ascii |

Tabel 9

## 11.4 Communication driver

To develop your own software for data communication , e.g. between a PC and MULTICAL® 41, below pseudo code can be used as a draft. The example shows a request for /#1:

```
mscomm1.Settings = "300,E,7,2"  
mscomm1.InBufferCount = 0  
mscomm1.Output = "/#1"  
Do While mscomm1.OutBufferCount <> 0  
Handle Windows Events  
Loop  
Delay for 300 ms
```

```
mscomm1.Settings = "1200,E,7,2"  
mscomm1.InBufferCount = 0  
mscomm1.InputLen = 1  
strData = ""  
While mscomm1.InBufferCount > 0  
strData = strData & mscomm1.Input  
Handle Windows Events  
Wend
```

In connection with the development of the concrete communication driver, above should only be used as an example of the essential commands, whereas e.g. "timers" and "flags" are omitted for clarity.

## 12 Calibration and Verification

In order to be able to carry out test/verification of MULTICAL® 41 at a minimum of time the meter has a testing mode. When the meter is in testing mode the program runs approx. 4 times faster than in standard mode. Testing mode also has some extra functions as described below.

(NB. MULTICAL® 41 uses approx. 4 times more current in testing mode. However, under normal circumstances the meter will only be in testing mode e.g. 9 hours per 5 years, and this has no influence on the total lifetime of the battery).

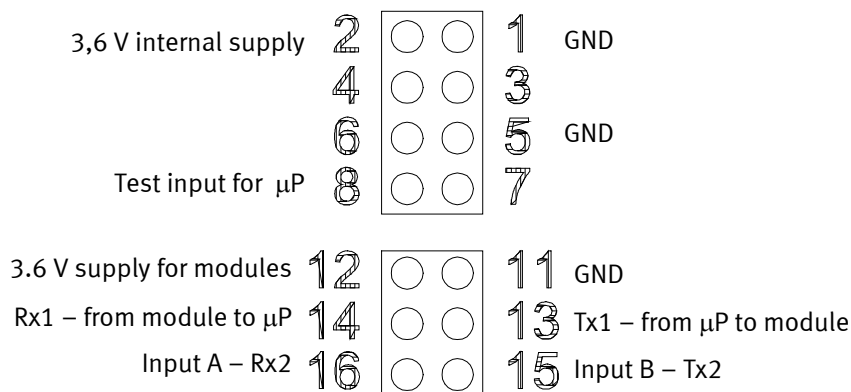

Figure 27: Module and test plug (Nos. 1-8 are sealed with a verification seal)

### Flow verification

Flow measurement operates with absolute time measurement.

#### STARTING UP

Min. 16 seconds must elapse from start-up and until true flow reading has been reached and calibration has started.

#### FLOW MEASUREMENT

To obtain a correct flow measurement calibration must take min. 2 minutes.

#### EVACUATION

Do not evacuate MULTICAL® 41 (subject to vacuum).

### Calculator verification

Volume simulation is made by means of the built-in "Autointegration" function (see section 12.2).

## 12.1 Testing mode

### Extra display readings

In addition to the display readings in standard mode there is an extra testing counter/verification register for volume. The testing counter appears as extra readings immediately after the main counter for volume (Q). The resolution of the extra testing counter is for volume (Q') 1 [ml]. The main counter does not change unit or resolution in testing mode.

NB.: The resolution for the extra testing counter applies to all meter sizes.

### Testing mode

The meter can be switched to testing mode by pressing the internal button marked "P" for approx. 5 sec. or serially through the test plug in the meter. When the meter is in testing mode a "P" appears to the left in the meter display. The internal push button is placed under the top cover. When the internal push button is activated the meter changes to testing mode, whereas subsequent activation for 5 seconds brings the meter back to standard operation.

In testing mode MULTICAL® 41 runs through an integration sequence of 4 sec. Through this sequence the water flow is measured with an average interval of 1 sec. At the end of the sequence the volume calculations are made.

All display values are updated with an interval of 4 sec.

**To be able to operate the internal button and the test plug, modules or seals, if any, over the test plug must be removed.**

### Resetting test counter Q'

This extra counter is reset by briefly pressing the internal button marked "P" or serially.

When resetting the testing counter, the internal water residue in the meter is also reset. This means that accumulated water may be missing in the main counters after repeated resets.

### Standard mode

The meter can be put into standard mode again by pressing the internal button marked "P" for approx. 5 sec. or serially via the test plug in the meter. If the meter is not put into standard mode, it will automatically change into standard mode after approx. 8 hours. When the meter has returned to standard mode the "P" which earlier appeared in the left side of the meter's display will be turned off. Instead an "E" may appear in the left side of the display (see section 7.4 *Information codes*).

### External control of testing counter Q'

It is possible to control the testing counter externally by means of a switch function. The switch must be connected to pins 16 and 11 of the test plug. Only possible when pins 7-8 are short-circuited under the verification seal. The function works as follows:

1. When the connection is established, the verification register Q' is reset, and the counting starts
2. When the connection is released, the verification register Q' is locked
3. Subsequently, the register can be read from the display or serially
4. A new test point can be carried out starting from point 1

### 12.2 Pulse Interface for MULTICAL® 41

When the meter is in testing mode, Pulse Interface type 66-99-109 can be used during verification on the test rigs with pulse interface.

The pulse output on the terminals 6-7-8 cannot be used for testing MULTICAL® 41.

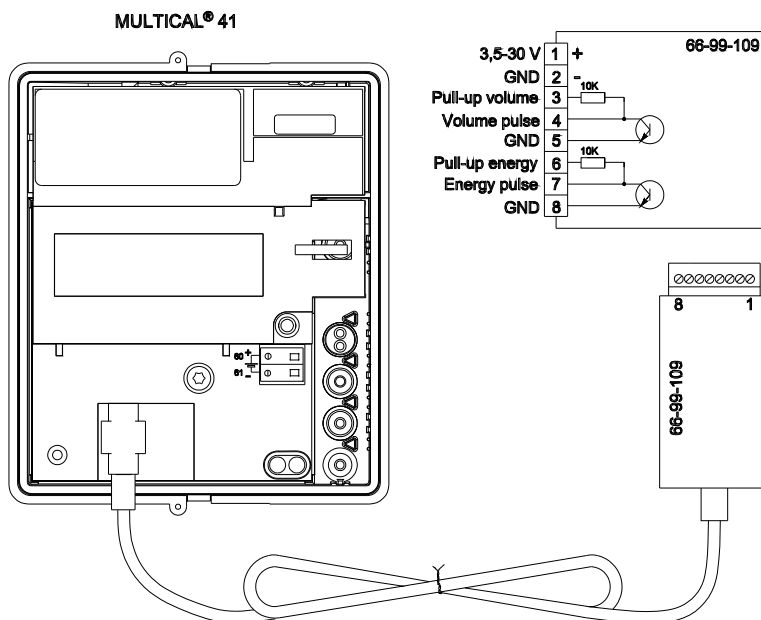

Figure 28

- Supply: 3.5-30 VDC < 5 mA
- Stand-by: < 1 mA
- Pulse: < 30 V < 15 mA
- Pulse duration: 50% Duty cycle or pulse < 0.1 sec.

| Meter size | Volume (pulses/litres) |
|------------|------------------------|
| MC 41      | MC 41                  |
| Q3: 1.6    | 100                    |

## 13 Approvals

### 13.1 Type approvals

MULTICAL® 41 is type approved in Denmark according to OIML R 49-1:2003 and R 49-2:2004. The test reports, project 08-3417-VFMTY0403 and E820128, are made by FORCE and DELTA. For further information on type approvals and verification, please contact Kamstrup A/S.

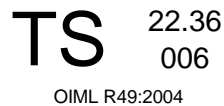

### 13.2 CE-Marking

MULTICAL® 41 is CE marked in accordance with following directives:

|               |             |
|---------------|-------------|
| EMC-directive | 2004/108/EC |
| LV-directive  | 73/23/EØF   |

### 13.3 Measuring instrument directive

MULTICAL® 41 is available with marking according to MID (2004/22 EC). The certificates have the following numbers:

|           |                   |
|-----------|-------------------|
| B-Module: | DK-0200-MI001-003 |
| D-Module: | DK-0200-MIQA-001  |



**Declaration of Conformity**  
**Overensstemmelseserklæring**  
**Déclaration de conformité**  
**Konformitätserklärung**  
**Deklaracja Zgodności**  
**Declaración de conformidad**  
**Declaratie de conformitate**

**We**  
**Vi**  
**Nous**  
**Wir**  
**My**  
**Noşotros**  
**Noi**

**Kamstrup A/S**  
**Industrivej 28, Stilling**  
**DK-8660 Skanderborg**  
**Denmark**  
**Tel: +45 89 93 10 00**

declare under our sole responsibility that the product(s):  
*erklærer under eneansvar, at produkt(erne):*  
*déclarons sous notre responsabilité que le/les produit(s):*  
*erklären in alleiniger Verantwortung, dass/die Produkt(e):*  
*deklarujemy z pełną odpowiedzialnością że produkt(y):*  
*Declaramos, bajo responsabilidad propia que el/los*  
*producto*  
*declarăm pe proprie raspundere ca produsul/produsele:*

| Instrument          | Type  | Type No.:  | Classes                         | Type Approval Ref.:                    |
|---------------------|---|--|---------------------------------|--|
| Heat Meter          | MULTICAL® 401   | 66-V and 66-W  | CI 2/3, M1, E1                  | DK-0200-MI004-001                      |
| Temperature Sensors | PL and DS   | 65-00-0A/B/C/D<br>66-00-0F/G<br>65-00-0L/M/N/P<br>66-00-0Q3/4<br>65-56-4 | M1                              | DK-0200-MI004-002                      |
| Flow Sensor         | ULTRAFLOW®<br>qp 0.6...400 m³/h                         | 65-S/R/T   | CI 3, M1, E1                    | DK-0200-MI004-003                      |
| Flow Sensor         | ULTRAFLOW®<br>qp 0.6...40 m³/h<br>and qp 150...400 m³/h | 65-S/R/T   | CI 2/3, M1, E1                  | DK-0200-MI004-003                      |
| Calculator          | MULTICAL® 601<br>MULTICAL® 801                          | 67-A/B/C/D<br>67-F/G/K/L   | M1, E1/E2<br>M1, E1/E2          | DK-0200-MI004-004<br>DK-0200-MI004-009 |
| Flow Sensor         | ULTRAFLOW® 54   | 65-5   | CI 2/3, M1<br>E1/E2             | DK-0200-MI004-008                      |
| Water Meter         | MULTICAL® 41<br>MULTICAL® 61                            | 66-Z<br>67-Z   | CI 2, M1, E1<br>CI 2, M1, E1, B | DK-0200-MI001-003<br>DK-0200-MI001-010 |

is/are in conformity with the requirements of the following directive(s):

*er i overensstemmelse med kravene i følgende direktiv(er):*

*est/sont conforme(s) aux exigences de la/des directive(s):*

*mit den Anforderungen der Richtlinie(n) konform ist/sind:*

*jest/są zgodne z wymaganiami następujących dyrektyw:*

*es/son conforme(s) con los requerimientos de la(s) siguiente(s) directiva(s):*

*este/sunt in conformitate cu cerintele urmatoarelor directive:*

Measuring Instrument Directive      2004/22/EC  
 EMC Directive                              2004/108/EC  
 LVD Directive                                2006/95/EC  
 PE-Directive (Pressure)                97/23/EC  
 R&TTE                                         1999/5/EC

**Date: 2010-01-26**

**Sign.:**

**Kurt Stochholm**  
**Quality Assurance Manager**

## 14 Trouble Shooting

MULTICAL® 41 is constructed with a view to fast and simple installation as well as long-term, reliable operation at the water consumers.

Should you, however, experience an operating problem with the meter, the error detection table below might help you clarify the possible cause.

If the meter needs to be repaired, we recommend that only battery and communication modules are replaced. Alternatively, the entire meter must be replaced.

Major repairs can only be made in our factory.

Before you send in the meter for repair, we ask you kindly to go through below error detection table to help clarify the possible cause of the problem:

| Symptom  | Possible cause                     | Suggested corrections   |
|--|------------------------------------|---|
| No display function (blank display)              | No power supply                    | Replace the battery or check the mains supply. Is there 3.6 VDC on the terminals 60(+) and 61(-)? |
| No accumulation of volume (m <sup>3</sup> ) etc. | Read "info" on the display         | Check the error indicated by the info code (see section 7.4)                                      |
|  | If "info" = 000 ⇒                  | Check that the flow direction corresponds with the arrow on the flow sensor                       |
|  | If "info" = 016 ⇒                  | There is air in the flow sensor. Release air from the system and check the meter once more        |
| No accumulation of volume (m <sup>3</sup> )      | The flow sensor angle is incorrect | Check that the flow direction corresponds with the arrow on the flow sensor                       |

## 15 Disposal

Kamstrup A/S is environmentally certified according to ISO 14001, and as part of our environmental policy we use as far as possible materials that can be recycled in an environmentally correct way.

• **Disposal made by Kamstrup A/S**

Kamstrup A/S is willing to dispose of worn out meters in an environmentally safe manner – please contact us before sending the meters.

The disposal arrangement is free of charge for the customer, who only pays for transportation to Kamstrup A/S.

• **If the customer sends in products for disposal**

Do not separate the meters prior to dispatch. Submit the entire meter for nationally/locally approved destruction. Copy of this page should be attached to inform on the contents.

• **Disposal made by the customer**

The meters must be separated as described below. The separated parts must be sent for approved destruction. Do not expose the batteries to mechanical impact and the lead-in wires must not be short-circuited during transport.

| Subject   | Material  | Recommended destruction                   |
|---|---|---|
| Lithium cells in MULTICAL® 41                     | Lithium and Thionylchlorid >UN 3090< D-cell: 4.9 g lithium                          | Approved depositing of lithium cells      |
| PC boards in MULTICAL® 41 (LC display is removed) | Copper epoxide laminate with soldered components                                    | Print board scrap for recycling of metals |
| LC display  | Glass and liquid crystals   | Approved processing of LC displays        |
| Cables for flow sensors and sensors               | Copper with silicone mantle   | Cable recycling                           |
| Transparent top cover                             | PC  | Plastic recycling                         |
| Black base unit                                   | ABS with TPE gaskets  | Plastic recycling                         |
| Internal cover                                    | PP  | Plastic recycling                         |
| Other plastic parts, cast                         | PC + 20% glass  | Plastic recycling                         |
| Meter case  | > 84% alpha brass/red brass<br>< 15% standard steel (St 37)<br>< 1% stainless steel | Metal recycling                           |
| Packing   | Environmental cardboard   | Cardboard recycling                       |

Please direct any questions you may have concerning environmental matters to:

**Kamstrup A/S**  
 FAO: Environmental and quality assurance department  
 Fax.: +45 89 93 10 01  
 info@kamstrup.dk

## 16 Documents

|                       | <b>Danish</b> | <b>English</b> | <b>German</b> |
|-----------------------|---------------|----------------|---------------|
| Technical Description | 5512-278      | 5512-313       | -             |
| Data sheet            | 5810-474      | 5810-487       | 5810-481      |
| Installation guide    | 5512-277      | 5512-307       | 5512-309      |
| User's manual         | 5512-276      | 5512-308       | 5512-310      |

