

MULTICAL® 601 & ULTRAFLOW® 14 Cooling

DATA SHEET

- Moisture resistant flowpart
- Ultrasonic flow sensor
- Large dynamic range
- Exceptionally accurate
- Longevity
- 24 VAC, 230 VAC or 10 years' battery supply
- Data logging for 460 days, 36 months and 15 years
- Room for two extra plug-in modules
 - Top module: Clock back-up, CE+CV outputs, PQ-limiter and M-Bus
 - Base module: M-Bus, RF/Router, LonWorks, 0/4...20 mA outputs and pulse inputs for electricity and water meters

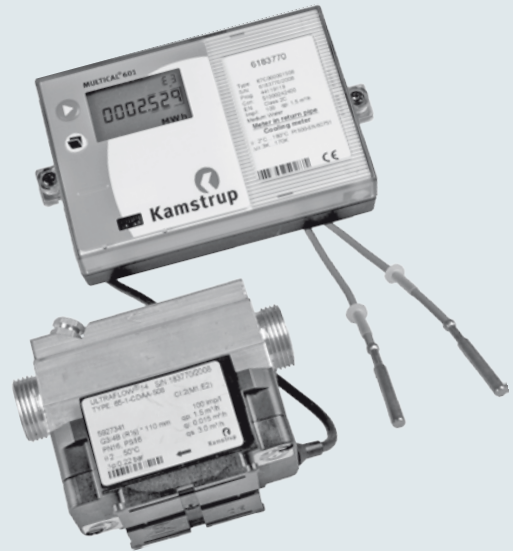

Application

MULTICAL® 601 and ULTRAFLOW® 14 are used for measurement of cooling in all water based plants with flow temperatures from 2°C to 50°C and with ULTRAFLOW® 14 between q_p 1.5 m³/h and q_p 100 m³/h.

The meter is simple to install, read and test.

MULTICAL® 601 and ULTRAFLOW® 14 contributes to keeping the annual operating costs at a minimum with its unique combination of high measuring accuracy and long lifetime.

MULTICAL® 601 receives volume pulses from the connected ULTRAFLOW® 14 and calculates the energy for every predetermined water volume. The energy calculation includes temperature measurements in flow and return

as well as correction for density and heat content according to EN 1434.

MULTICAL® 601 and ULTRAFLOW® 14 can be supplied by either battery, 230 VAC or 24 VAC.

MULTICAL® 601 can be extended with two internal modules – a top module with clock backup, pulse outputs, M-Bus or valve control and a base module with M-Bus, radio, LonWorks or 0/4...20 mA outputs. Furthermore, the base module includes two additional pulse inputs for connection of water and electricity meters, making it possible to collect all consumption data with one single automatic data reading.

ULTRAFLOW® 14 is a static flow sensor based on the ultrasonic measuring

principle for use in cooling installations where water is used as the energy conveying medium.

ULTRAFLOW® 14 is not suitable for use with other media than water and should therefore not be used with e.g. non-freezing additives like glycol.

The flow is measured using bidirectional ultrasonic technique based on the transit time method, with proven long-term stability and accuracy. Two ultrasonic transducers are used to send the sound signal both against and with the flow direction.

The ultrasonic signal travelling with the flow direction reaches the opposite transducer first. The time difference between the two signals can be converted into a flow velocity and thus a volume.



MULTICAL® 601 & ULTRAFLOW® 14 COOLING DATA SHEET



Indhold

Calculator functions	3
Electrical data	8
Flow data	9
Pressure loss	10
Pressure loss chart	10
Mechanical data	11
Materials	11
Order specifications	12
Accessories	14
Dimensional sketches calculator	15
Dimensional sketches temperature sensors	15
Dimensional sketches flow sensors	16
Installation of calculator	18
Installation example with suspension	18
Installation of temperature sensors	19
Mounting of flow sensors	19
Mounting of ULTRAFLOW® 14	20

MULTICAL® 601 & ULTRAFLOW® 14 COOLING DATA SHEET



Calculator functions

Energy calculation

MULTICAL® 601 calculates energy based on the formula in EN 1434-1:2004, in which the international temperature scale from 1990 (ITS-90) and the pressure definition of 16 bar is used.

The energy calculation can in a simplified way be expressed as:

$$\text{Energy} = V \times \Delta\Theta \times k.$$

V is the supplied water volume

$\Delta\Theta$ is the temperature difference measured

k is the thermal coefficient of water

The calculator always calculates energy in [Wh], and then it is converted into the selected measuring unit.



E [Wh] =	$V \times \Delta\Theta \times k \times 1.000$
E [kWh] =	$E [\text{Wh}] / 1.000$
E [MWh] =	$E [\text{Wh}] / 1.000.000$
E [GJ] =	$E [\text{Wh}] / 277.780$
E [Gcal] =	$E [\text{Wh}] / 1.163.100$

Application

MULTICAL® 601 operates with 9 different energy formulas, E1...E9, that are all calculated in parallel in connection with each integration no matter how the meter is configured.

In connection with cooling the following energy calculations are used:

$$E3 = V1(T2 - T1) \quad \text{Cooling energy} \quad (V1 \text{ in flow or return})$$

$$E8 = m^3 \times T1 \quad (\text{Flow pipe})$$

$$E9 = m^3 \times T2 \quad (\text{Return pipe})$$

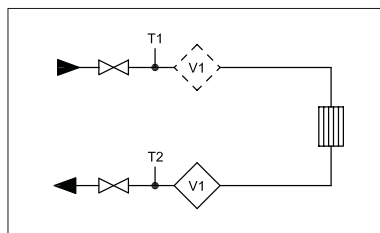

Closed thermal system with 1 flow sensor

MULTICAL® 601 & ULTRAFLOW® 14 COOLING DATA SHEET



Calculator functions

Flow measurement

The flow indication is updated every 10 seconds.



Power measurement

MULTICAL® 601 calculates current power on the basis of current water flow and the temperature difference measured in connection with the latest integration.

Current power is updated in the display simultaneously with the flow update.

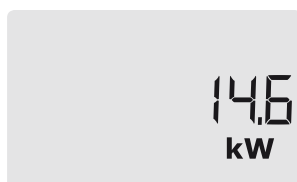

Min. and max. flow and power

MULTICAL® 601 registers minimum and maximum flow and power on a monthly as well as on a yearly basis. The registrations which appear from the display or can be read via data communication include max. and min. flow and power values, all with date indication.

All max. and min. values are calculated as largest and smallest average respectively of a number of current flow or power measurements. The average period used for all calculations is selected in the interval 1...1440 min.

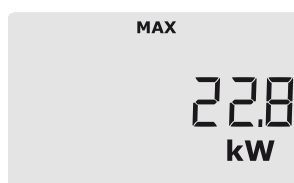

Temperature measurement

MULTICAL® 601 and ULTRAFLOW® 14 is delivered with Pt500 sensors in 2-wire versions.

The measuring circuit includes a high resolution analog/digital converter with a temperature range of 0.00...185.00°C.

In addition to current temperatures for the energy calculation average temperatures on a yearly and monthly basis can also be displayed.

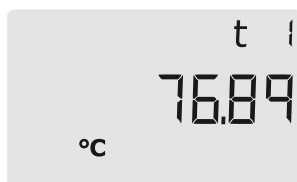

MULTICAL® 601 & ULTRAFLOW® 14 COOLING DATA SHEET



Calculator functions

Display functions

MULTICAL® 601 is equipped with a clear LCD-diplay including 8 digits, units of measurement and information panel. In connection with energy and volume readings 7 digits and the units of measurement to match are used, whereas 8 digits are used when e.g. meter number is read.

As a starting point the display shows accumulated energy. When the push buttons are activated the display reacts immediately by calling other readings. The display automatically returns to accumulated energy reading 4 minutes after the latest activation of the push buttons.

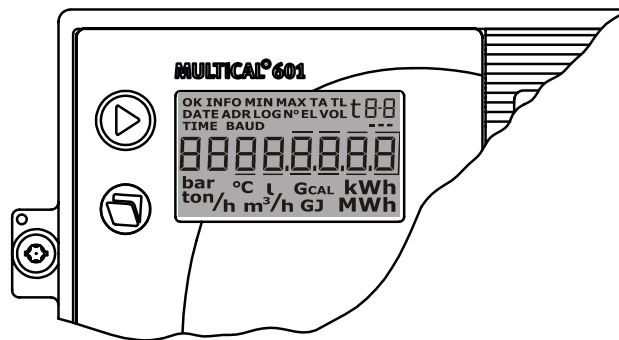

The upper push button is used to switch between the primary readings. The consumers typically use the first primary readings in connection with self-reading for billing purposes. The lower push button is used to show secondary information on the selected primary reading.

Info codes

MULTICAL® constantly monitors a number of important functions, e.g. power supply and temperature sensors. Should a serious error occur in the measuring system or in the installation, a flashing “info” will appear in the display whilst the error exists. The “Info” panel will automatically disappear when the error has been corrected.

An Info Event Logger indicates how many times the info code has been changed.

The info logger stores the latest 50 changes, of which 36 can be displayed.

Info code	Description
0	No irregularities
1	Supply voltage connected after cut off
4	T2 sensor outside range, short-circuited or cut off
8	T1 sensor outside range, short-circuited or cut off
ULTRAFLOW® 14 info (if activated CCC=4XX)	
16	Flow sensor V1, datacomm error, signal too low or wrong flow direction
2048	Flow sensor V1, wrong meter factor
4096	Flow sensor V1, signal too low (Air)
16384	Flow sensor V1, wrong flow direction



MULTICAL® 601 & ULTRAFLOW® 14 COOLING DATA SHEET



Calculator functions

Data loggers

MULTICAL® 601 contains a permanent memory (EEPROM), where the results of a number of various data loggers are stored. The meter contains the following data loggers which can be read on the display or via serial data:

Data logging interval	Data logging depth	Logged value
Yearly logger	15 years	Counter registers (as seen on the display)
Monthly logger	36 months	Counter registers (as seen on the display)
Daily logger	460 days	Consumption (increase)/day
Hourly logger (option)	1392 hours	Consumption (increase)/hour
Programmable data logger (option)	1080 loggings (e.g. 45 days' hour loggings or 11 days' 15 min. loggings)	Up to 40 optional registers and values
Info logger	50 events	Info code and date

Pulse inputs VA and VB

MULTICAL® 601 has two extra pulse inputs, VA and VB, to collect and accumulate pulses remotely, e.g from cold-water meters and electricity meters. The pulse inputs are physically placed on the "base modules".

The pulse inputs VA and VB function independently of the other inputs/outputs.



Voltage supply

MULTICAL® 601 is available with battery supply, 230 VAC mains module, or 24 VAC mains module. The supply modules are exchangeable without breaking the verification seal.

Plug-in modules

Plug-in modules can be added to MULTICAL® 601 both in the calculator top (top modules) and in the base unit (base modules), in this way the meter can adapt to various applications and data reading methods.

MULTICAL® 601 & ULTRAFLOW® 14 COOLING DATA SHEET



Calculator functions

Programming and testing

METER TOOL for MULTICAL® 601 is a Windows® -based software which includes all facilities for calculator programming. If the software is used together with VERIFICATION EQUIPMENT for MULTICAL® 601, the calculator can be tested.

Tariff functions

MULTICAL® 601 has 2 extra registers TA2 and TA3 to accumulate energy parallelly to the main register based on a programmed tariff condition. No matter which tariff type you select the tariff registers will be displayed as TA2 and TA3.

The main register is always accumulated, irrespective of the selected tariff function, as it is considered the legal billing register. Tariff conditions TL2 and TL3 are monitored before each integration. If the tariff conditions are fulfilled, the consumed cooling energy is accumulated in either TA2 or TA3, as well as the main register.

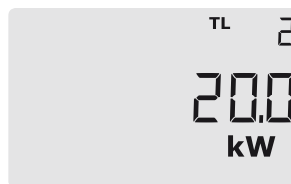

MULTICAL® 601 & ULTRAFLOW® 14 COOLING

DATA SHEET



Electrical data

Typical accuracy	
– Calculator	$E_C \pm(0.15 + 2/\Delta\Theta)\%$
– Sensor set	$E_T \pm(0.4 + 4/\Delta\Theta)\%$
– Flow sensor	$E_F \pm(1 + 0.01 \times q_p/q)\%$
Supply voltage	3.6 VDC \pm 0.1 V
Battery	3.65 VDC, D-cell lithium
Stand-by current	< 85 μ A
Replacement interval	
– Mounted on wall	10 years @ $t_{BAT} < 30^\circ\text{C}$ The replacement interval is reduced when using data modules, frequent data communication or high ambient temperature
Mains supply	230 VAC \pm 15/-30%, 50/60 Hz 24 VAC \pm 50%, 50/60 Hz
Insulation voltage	4 kV
Power supply	< 1 W
Backup supply	Integral super-cap eliminates operational stop-down due to short-term power cuts
EMC data	Domestic and light industrial
Calculator data	
Display	LCD – 7 (8) digits with a digit height of 7.6 mm
Resolution	9999.999 – 99999.99 – 999999.9 – 9999999
Energy units	MWh – kWh – GJ – Gcal
Temperature range	Θ : 2...180°C
Differential range	$\Delta\Theta$: 3...170 K
Data logger (Eeprom)	
– Standard	460 days, 36 months, 15 years, 50 info codes
– Option	Data loggers with larger depth and hour interval
Clock/calendar	
– Standard	Clock, calendar, leap-year compensation, target date
– Option	Real time clock with battery back-up
Data communication	
– Standard	KMP protocol with CRC16 used for optical communication and for top and base modules
– Option	MULTICAL® 66-CDE compatible data for base modules
Power in temperature sensors	< 10 μ W RMS
Temperature measurement	
Sensor inputs T1, T2	
– Measuring range	0.00...185.00°C
Max. cable lengths	
– Pt500, 2-wire	2 x 0.25 mm ² : 10 m 2 x 0.50 mm ² : 20 m

MULTICAL® 601 & ULTRAFLOW® 14 COOLING DATA SHEET



Electrical data

Pulse inputs VA and VB VA: 65-66 and VB: 67-68	Water meter connection FF(VA) and GG(VB) = 01...40	Electricity meter connection FF(VA) and GG(VB) = 50...60
Pulse input	680 kΩ pull-up to 3.6 V	680 kΩ pull-up to 3.6 V
Pulse ON	< 0.4 V for > 0.1 sec.	< 0.4 V for > 0.1 sec.
Pulse OFF	> 2.5 V for > 0.1 sec.	> 2.5 V for > 0.1 sec.
Pulse frequency	< 1 Hz	< 3 Hz
Electrical isolation	No	No
Max. cable length	25 m	25 m

Pulse outputs CE and CV – via top module 67-08	
Type	Open collector (OB)
Pulse length	32 msec. or 100 msec.
External voltage	5...30 VDC
Current	1...10 mA
Residual voltage	$U_{CE} \approx 1 \text{ V}$ at 10 mA
Electrical isolation	2 kV
Max. cable length	25 m

Flow data

Nom. flow q_p [m ³ /h]	Nom. diameter [mm]	Meter factor ^{*)} [imp./l]	Dynamic range $q_i:q_p$	$q_s:q_p$	Flow @125 Hz ^{**)} [m ³ /h]	$\Delta p@q_p$ [bar]	Min. cut off [l/h]
1.5	DN15 & DN20	100	1:100	2:1	4.5	0.22	3
2.5	DN20	60	1:100	2:1	7.5	0.03	5
3.5	DN25	50	1:100	2:1	9	0.07	7
6	DN25	25	1:100	2:1	18	0.20	12
10	DN40	15	1:100	2:1	30	0.06	20
15	DN50	10	1:100	2:1	45	0.14	30
25	DN65	6	1:100	2:1	75	0.06	50
40	DN80	5	1:100	2:1	90	0.05	80
60	DN100	2.5	1:100	2:1	180	0.03	120
100	DN100	1.5	1:100	2:1	300	0.07	200

^{*)} The meter factor can be seen on the label on the side of the meter.

^{**)} Saturation flow. Max. pulse frequency 128 Hz is maintained at higher flow rates.

MULTICAL® 601 & ULTRAFLOW® 14 COOLING DATA SHEET



Pressure loss

Graph	q_p [m³/h]	Nom. diameter [mm]	k_v *)	Q@0.25 bar [m³/h]
A	0.6 & 1.5	DN15 & DN20	3.2	1.6
B	2.5 & 3.5 & 6	DN20 & DN25	13.4	6.7
C	10 & 15	DN40 & DN50	40	20
D	25	DN65	102	51
E	40	DN80	179	90
F	60 & 100	DN100	373	187

*) $q = k_v \times \sqrt{\Delta p}$

Pressure loss chart

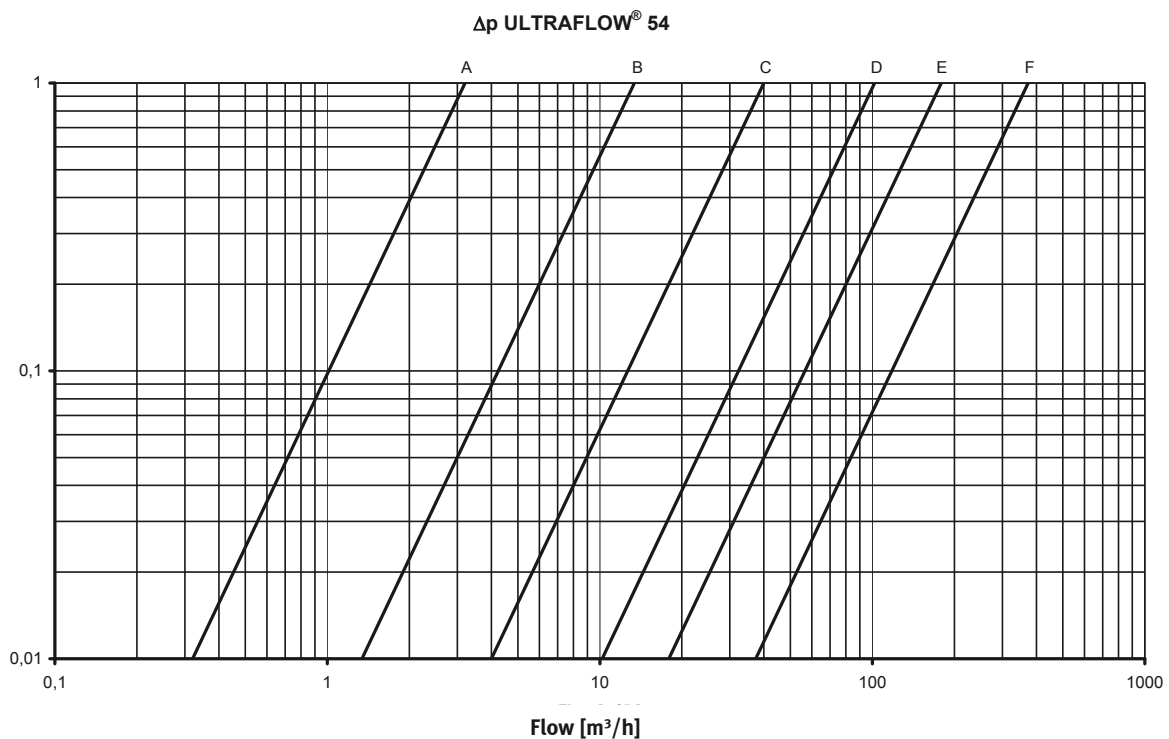

MULTICAL® 601 & ULTRAFLOW® 14 COOLING DATA SHEET



Mechanical data

Environmental class	Meets EN 1434 Class A
Ambient temperature	5...55°C non condensing, closed location (indoor installation)
Protection class	
– Calculator	IP54
– Flow sensor	IP65
Storage temperature	-25...60°C (drained flow meter)
Weight	
– MULTICAL® 601	0.4 kg excluding temperature sensors and flow sensor
– ULTRAFLOW® 14	See Dimension sketches on page 16-17
Flow sensor cable (between flowpart and calculator)	2.5 m Must not be removed/changed
Connection cables	ø3.5...6 mm
Supply cable	ø5...10 mm

Materials

MULTICAL® 601

Top cover	Thermoplastic, PC
Base unit	Thermoplastic, PP with thermoplastic elastomer TPE gaskets
Print box	Thermoplastic, ABS
Wall bracket	Thermoplastic, PC 30% GF

ULTRAFLOW® 14

Wetted parts

ULTRAFLOW® 14, q_p 1.5 m³/h

– Housing, gland	DZR brass (Dezincification resistant)
– Transducers	Stainless steel, W.no. 1.4401
– Gaskets	EPDM
– Reflectors	Thermoplastic, PES 30% GF and stainless steel, W.no. 1.4301
– Measuring pipe	Thermoplastic, PES 30% GF

ULTRAFLOW® 14, q_p 2.5 to 100 m³/h

– Housing, gland	DZR brass (Dezincification resistant)
– Housing, flange	Stainless steel W.no. 1.4308
– Transducers	Stainless steel, W.no. 1.4401
– Gaskets	EPDM
– Reflectors	Stainless steel, W.no. 1.4301
– Measuring pipe	Thermoplastic, PES 30% GF

Electronic housing

Base	Thermoplastic, PBT 30% GF
Lid	Thermoplastic, PC 10% GF

Connection cable

Copper cable with silicone jacket and inner Teflon insulation

MULTICAL® 601 & ULTRAFLOW® 14 COOLING DATA SHEET



Order specifications

MULTICAL® 601	Type 67-	<input type="checkbox"/>	<input type="checkbox"/>	<input type="checkbox"/>	<input type="checkbox"/>	<input type="checkbox"/>	<input type="checkbox"/>	<input type="checkbox"/>	<input type="checkbox"/>	<input type="checkbox"/>
Sensor connection										
Pt500 2-wire (T1-T2)	C									
Top module										
No module		0								
RTC (Real Time Clock)		1								
RTC + PQ or Δt -limiter + hourly data logger		3								
RTC + data output + hourly data logger		5								
RTC + M-Bus		7								
RTC + 2 pulse outputs for energy + volume + hourly data logger		8								
RTC + 2 pulse outputs for CE and CV + program data logger		B								
Base module										
No module			00							
Data + pulse inputs			10							
M-Bus + pulse inputs			20							
RadioRouter + pulse inputs			21							
Prog. data logger + RTC + 4...20 mA inputs + pulse inputs			22							
0/4...20 mA outputs			23							
LonWorks, FTT-10A + pulse inputs			24							
Radio + pulse inputs (internal antenna)			25							
Radio + pulse inputs (external antenna connection)			26							
Supply										
No supply						0				
Battery, D-cell						2				
230 VAC supply module w/transformer						7				
24 VAC supply module w/transformer						8				
Pt500 sensor set										
No sensor set							0			
Pocket sensor set w/1.5 m cable							A			
Pocket sensor set w/3.0 m cable							B			
Pocket sensor set w/5 m cable							C			
Pocket sensor set w/10 m cable							D			
Short direct sensor set w/1.5 m cable							F			
Short direct sensor set w/3.0 m cable							G			
Flow sensor/pick-up unit										
Supplied w/1 ULTRAFLOW®	(Please specify type)							1		
Meter type										
Cooling meter									5	
Country code (language on label etc.)										XX

When placing orders please state ULTRAFLOW® type numbers separately.

MULTICAL[®] 601 & ULTRAFLOW[®] 14 COOLING DATA SHEET



Order specifications

The list below shows type numbers for ULTRAFLOW[®] 14

Type number ^{*)}	q _p [m ³ /h]	q _i [m ³ /h]	q _s [m ³ /h]	Connection	Length [mm]	Meter factor [imp./l]	CCC (high res.)	Material
65-1-CDAA-XXX	1.5	0.015	3.0	G ³ / ₄ B (R ¹ / ₂)	110	100	419 (407)	Brass
65-1-CDAD-XXX	1.5	0.015	3.0	G1B (R ³ / ₄)	130	100	419 (407)	Brass
65-1-CDAF-XXX	1.5	0.015	3.0	G1B (R ³ / ₄)	190	100	419 (407)	Brass
65-1-CEAF-XXX	2.5	0.025	5.0	G1B (R ³ / ₄)	190	60	498	Brass
65-1-CGAG-XXX	3.5	0.035	7.0	G5/4B (R1)	260	50	451 (436)	Brass
65-1-CHAG-XXX	6.0	0.06	12	G5/4B (R1)	260	25	437 (438)	Brass
65-1-CHCB-XXX	6.0	0.06	12	DN25	260	25	437 (438)	Stainless steel
65-1-CJAJ-XXX	10	0.1	20	G2B (R1 ¹ / ₂)	300	15	478 (483)	Brass
65-1-CJCD-XXX	10	0.1	20	DN40	300	15	478 (483)	Stainless steel
65-1-CKCE-XXX	15	0.15	30	DN50	270	10	420 (485)	Stainless steel
65-1-CLCG-XXX	25	0.25	50	DN65	300	6	479	Stainless steel
65-1-CMCH-XXX	40	0.4	80	DN80	300	5	458 (486)	Stainless steel
65-1-FACL-XXX	60	0.6	120	DN100	360	2.5	470 (487)	Stainless steel
65-1-FBCL-XXX	100	1	200	DN100	360	1.5	480 (488)	Stainless steel

^{*)} XXX-code pertaining to final assembly, approvals etc. is determined by Kamstrup A/S. Some variants may not be included in national versions.

MULTICAL® 601 & ULTRAFLOW® 14 COOLING

DATA SHEET



Accessories

Calculator

Description

D-cell battery
 Data cable w/USB plug
 Infrared optical reading head w/USB plug
 Infrared optical reading head w/D-sub 9F
 Data cable RS 232, D-sub 9F
 Verification unit (used with METERTOOL)
 USB to serial converter

Type No.

66-00-200-100
 66-99-098
 66-99-099
 66-99-102
 66-99-106
 66-99-397/-398/-399
 59-20-147

METERTOOL for MULTICAL® 601

66-99-704

METERTOOL LogView for MULTICAL® 601

66-99-705

Temperatur sensors

Description

Change-over nipple M10 - R $\frac{1}{2}$ for direct short temperature sensor
 Change-over nipple M10 - R $\frac{3}{4}$ for direct short temperature sensor
 Sensor pocket, length = 65 mm
 Sensor pocket, length = 90 mm
 Sensor pocket, length = 140 mm

Type No.

65-56-491
 65-56-492
 65-57-324
 65-57-327
 65-57-314

Flow sensors

Glands including gaskets (PN16)

Size	Nipple	Union	Type No.	2 pcs.
DN15	R $\frac{1}{2}$	G $\frac{3}{4}$	-	6561-323
DN20	R $\frac{3}{4}$	G1	-	6561-324
DN25	R1	G5/4	6561-325	-
DN40	R1 $\frac{1}{2}$	G2	6561-315	-

Gaskets for flange meters (PN25)

Size	Type No.
DN20	2210-147
DN25	2210-133
DN40	2210-132
DN50	2210-099
DN65	2210-141
DN80	2210-140
DN100	1150-142

Gaskets for glands

Size (union)	Type No.
G $\frac{3}{4}$	2210-061
G1	2210-062
G5/4	2210-063
G2	2210-065

Please contact Kamstrup A/S for questions concerning further accessories.

MULTICAL® 601 & ULTRAFLOW® 14 COOLING DATA SHEET



Dimensional sketches calculator

Front dimensions of MULTICAL® 601

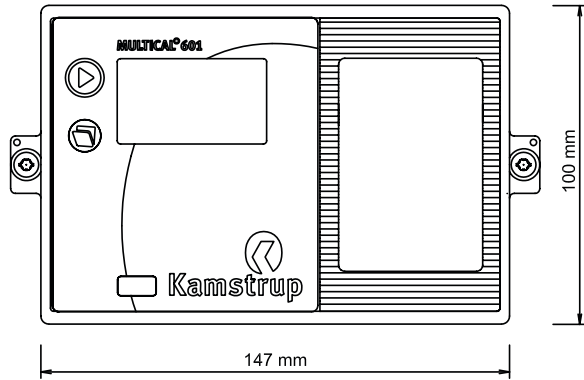

Wall-mounted MULTICAL® 601 seen from the side

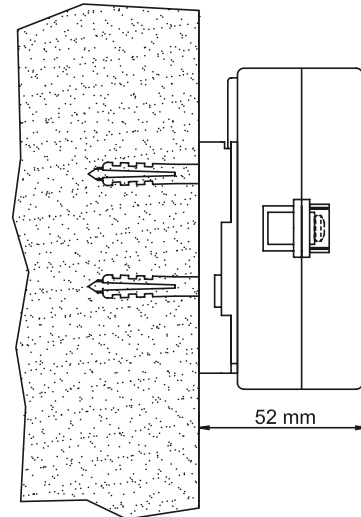

Dimensional sketches temperature sensors

Direct short sensor

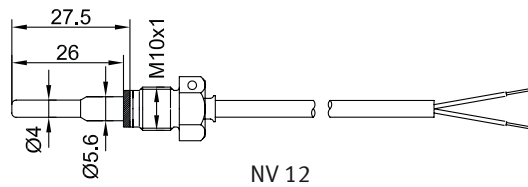

NV 12

Pocket sensor

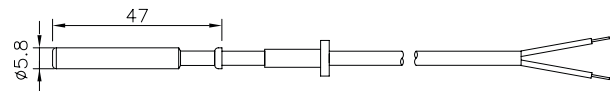

All measurements are in mm, unless otherwise stated.

Change-over nipples for direct short sensor

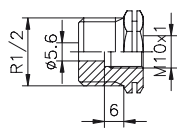

NV 22

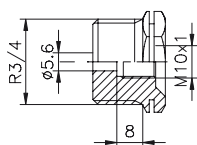

NV 27

Sensor pocket

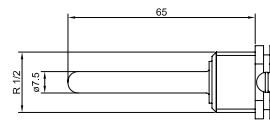

NV 22
65 mm

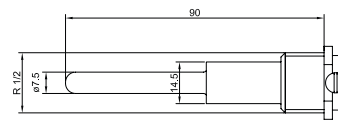

NV 22
90 mm

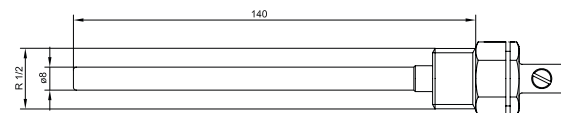

NV 22
140 mm

R1/2 and R3/4 thread according to ISO 7.1.

MULTICAL® 601 & ULTRAFLOW® 14 COOLING DATA SHEET



Dimensional sketches flow sensors

ULTRAFLOW® 14, G³/₄B and G1B

All measurements are in mm, unless otherwise stated.

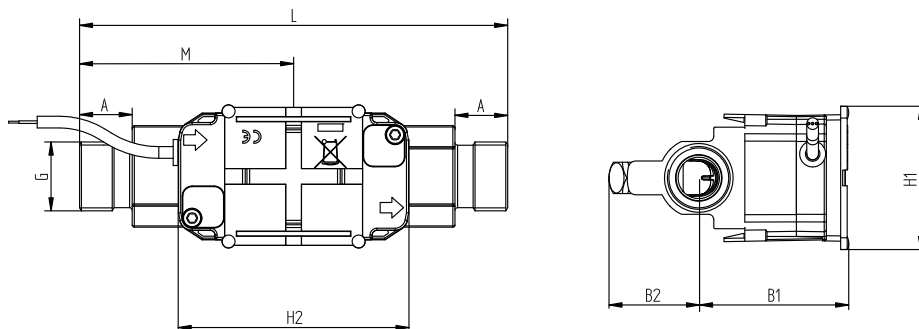

Thread ISO 228-1

Thread	L	M	H2	A	B1	B2	H1	App. weight [kg]
G ³ / ₄ B	110	L/2	89	10.5	58	35	55	0.8
G1B	130	L/2	89	20.5	58	35	55	0.9
G1B (q _p 1.5)	190	L/2	89	20.5	58	35	55	1.4
G1B (q _p 2.5)	190	L/2	89	20.5	58	36	55	1.3

ULTRAFLOW® 14, G⁵/₄B and G2B

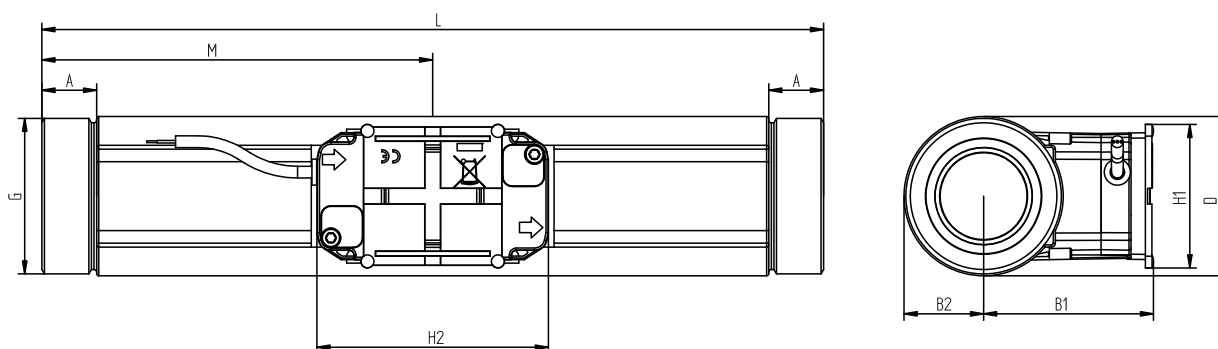

Thread ISO 228-1

Thread	L	M	H2	A	B1	B2	H1	App. weight [kg]
G ⁵ / ₄ B	260	L/2	89	17	58	22	55	2.3
G2B	300	L/2	89	21	65	31	55	4.5

MULTICAL[®] 601 & ULTRAFLOW[®] 14 COOLING DATA SHEET



Dimensional sketches flow sensors

ULTRAFLOW[®] 14, DN25 to DN50

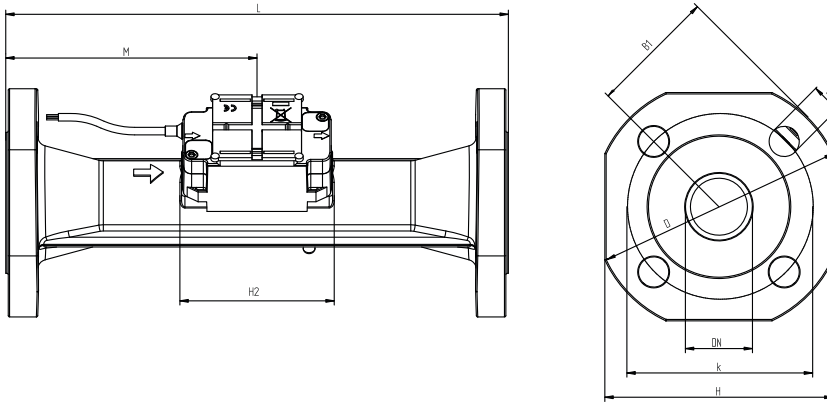

Flange EN 1092, type B, PN25

Nom. diameter	L	M	H2	B1	D	H	k	Bolts			App. weight [kg]
								No.	Thread	d ₂	
DN25	260	L/2	89	58	115	106	85	4	M12	14	5.0
DN40	300	L/2	89	<D/2	150	136	110	4	M16	18	8.3
DN50	270	155	89	<D/2	165	145	125	4	M16	18	10.1

ULTRAFLOW[®] 14, DN65, DN80 and DN100

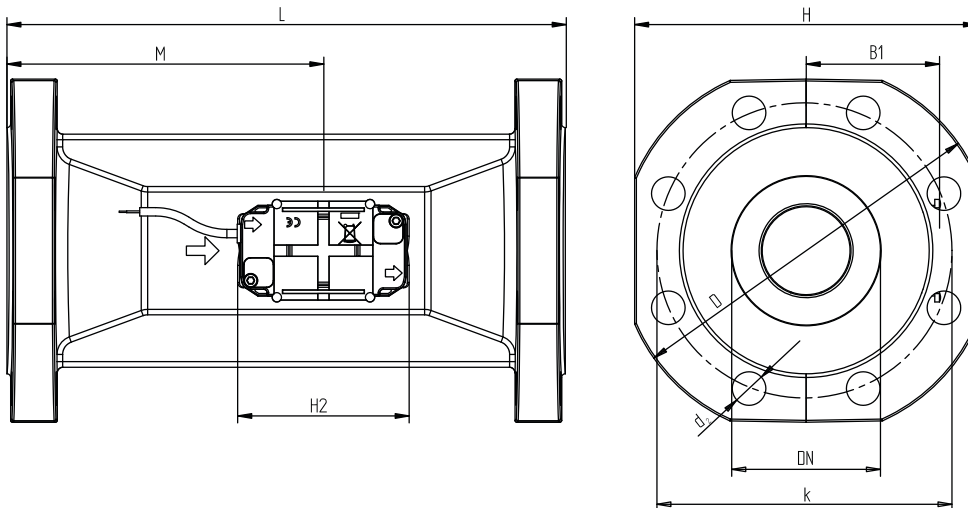

Flange EN 1092, type B, PN25

Nom. diameter	L	M	H2	B1	D	H	k	Bolts			App. weight [kg]
								No.	Thread	d ₂	
DN65	300	170	89	<H/2	185	168	145	8	M16	18	13.2
DN80	300	170	89	<H/2	200	184	160	8	M16	18	16.8
DN100	360	210	89	<H/2	235	220	190	8	M20	22	21.7

MULTICAL® 601 & ULTRAFLOW® 14 COOLING DATA SHEET



Installation of calculator

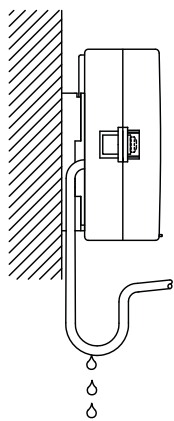

Front, vertical

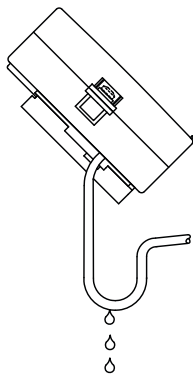

Front, at an angle
between horizontal and
vertical

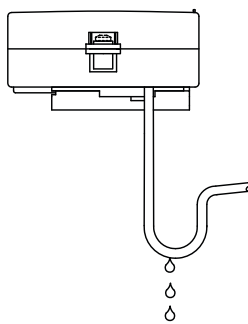

Front, horizontal

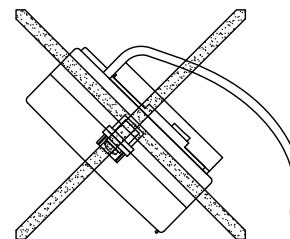
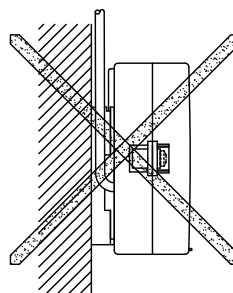

Note! Cables **must** be installed from below.

Installation example with suspension

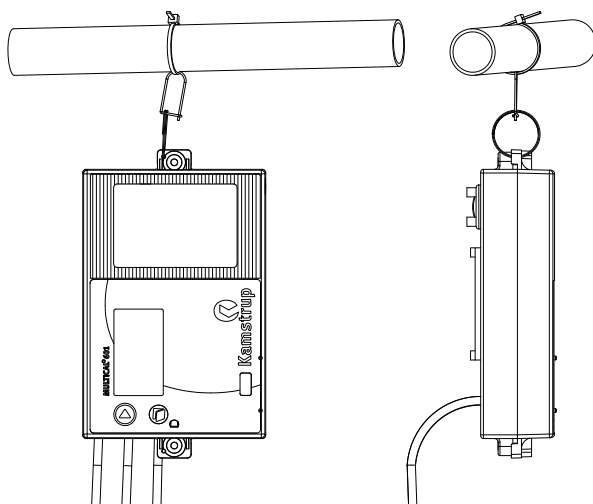

Note:
The suspension **must** not be used on condensing pipes.
Suspension kit item no. 5915-144. Not included.

MULTICAL® 601 & ULTRAFLOW® 14 COOLING DATA SHEET



Installation of temperature sensors

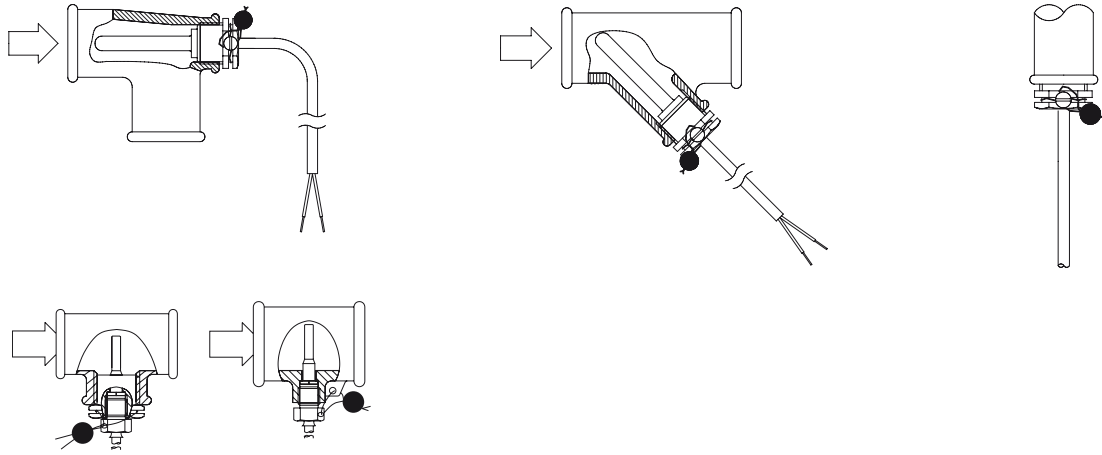

Temperature sensors must be mounted from below

Mounting of flow sensors

Before mounting the flow sensor, flush the system thoroughly and remove protection plugs/plastic membranes from the flow sensor. Correct flow sensor position (flow or return pipe) appears from the front label placed on the MULTICAL® 601. The flow direction is indicated by an arrow on the side of the flow sensor.

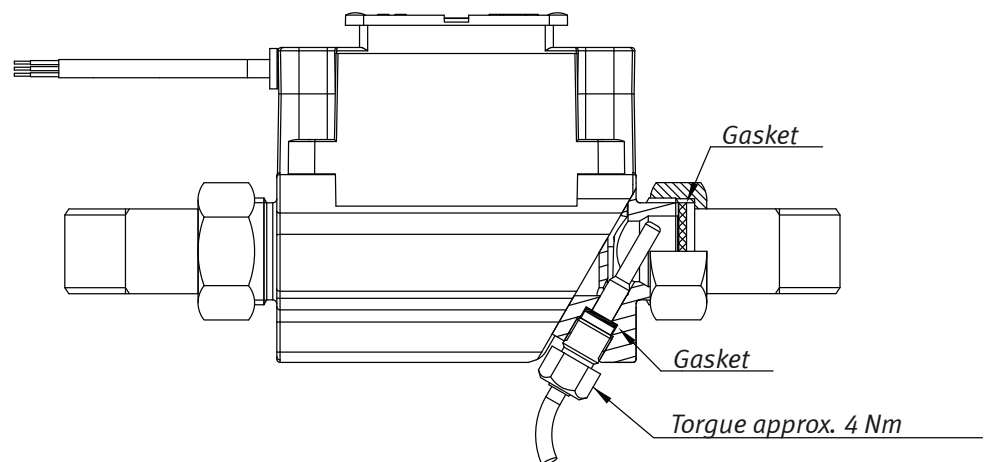

Glands and gaskets must be mounted as shown on the drawing above.

Straight inlet: ULTRAFLOW® 14 requires neither straight inlet nor outlet to meet the Measuring Instruments Directive (MID) 2004/22/EC, OIML R75:2002 and EN 1434:2007. Only in case of heavy flow disturbances before the meter will a straight inlet section be necessary. We recommend to follow the guidelines in CEN CR 13582.

To prevent cavitation, the operating pressure at the ULTRAFLOW® 14 must be min. 1.5 bar at q_p and min. 2.5 bar at q_s .

ULTRAFLOW® 14 must not be exposed to pressures below ambient pressure (vacuum).

MULTICAL® 601 & ULTRAFLOW® 14 COOLING DATA SHEET



Mounting of ULTRAFLOW® 14

ULTRAFLOW® 14 can be mounted vertically, horizontally or at any angle in between.

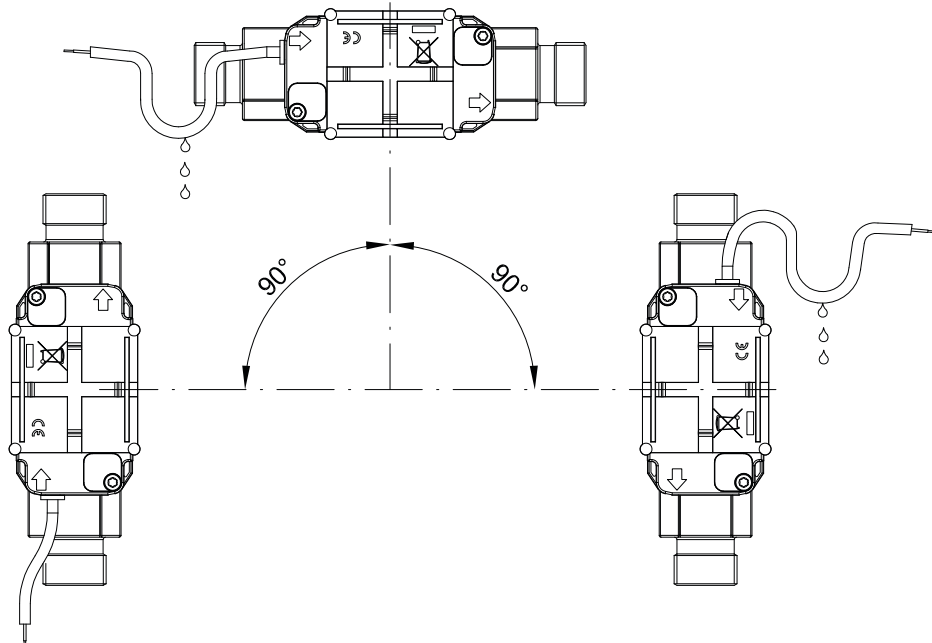

ULTRAFLOW® 14 may be turned upwards to maximum 45° in relation to horizontal.

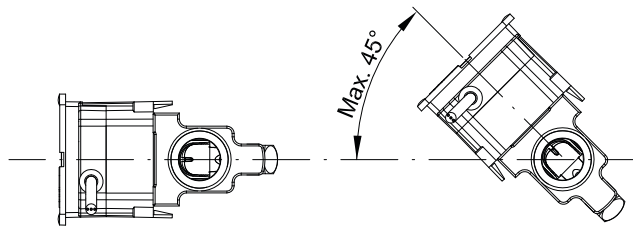

The ULTRAFLOW® 14 housing must **not** be mounted facing upwards or downwards.

