

Installation and user's guide

## GSM Modem 6



## Quick Guide

---

- 1 Run a signal test by activating the test button on the modem.
- 2 If the signal strength is below 12, an external antenna must be installed.**
- 3 The external antenna should be placed in a location that optimises the reception of the signal. Turn the external antenna around until the best position has been found. Run several signal tests while trying to find the best position.
- 4 You might use NetMonitor or a similar tool that can help to find the best position for the external antenna.
- 5 Before leaving the installation, test the signal strength by SMS. Make sure that all cabinets and doors are closed before sending the SMS.

## Tips

---

- Always install an external antenna when installing the unit in a metal cabinet. The antenna must be placed outside the cabinet.
- Use dual-band GSM antennas to optimise the performance.
- Note that fire doors, concrete and metal plates disturb and weaken the GSM signal.
- It is possible to order special directional antennas for areas with very poor signal conditions (please contact Kamstrup for further information).

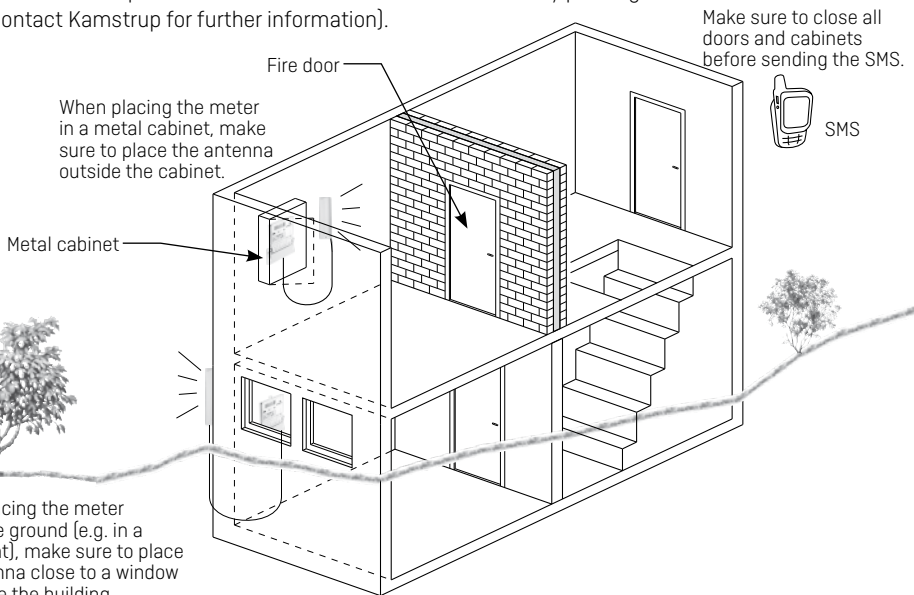

# Contents

---

<b>1</b>	<b>Mounting</b>	<b>4</b>
1.1	Mounting order	4
1.2	Start-up sequence	5
<b>2</b>	<b>Description</b>	<b>6</b>
2.1	Description of GSM Modem 6	6
2.2	Technical data	6
<b>3</b>	<b>Installation</b>	<b>7</b>
3.1	SIM card	7
3.2	GPRS	8
3.3	Signal test	8
3.4	Selecting antenna	9
3.4.1	<i>Internal antenna</i>	9
3.4.2	<i>External antenna (to be ordered separately)</i>	9
3.4.3	<i>Diagram for signal conversion</i>	10
3.4.4	<i>Automatic antenna selection</i>	11
3.5	Light Emitting Diodes (LEDs)	11
3.6	Connecting meters and M-Bus Master	12
3.7	Connecting control relays	13
3.8	Connecting status inputs	14
<b>4</b>	<b>M-Bus data logger (variant)</b>	<b>15</b>
4.1	Connecting M-Bus unit	15
<b>5</b>	<b>Error Detection Help</b>	<b>16</b>
<b>6</b>	<b>SMS commands</b>	<b>17</b>
<b>7</b>	<b>GSM Modem 6 Variant structure</b>	<b>20</b>

# 1 Mounting

---

GSM Modem 6, article number 68G6XXXXX, can be supplied with both 110/230 VAC and 24 VAC, and it is prepared for the mounting of an external antenna. See also "GSM Modem 6 Variant structure" on the last page of this document.

## 1.1 Mounting order

- 6** The modem must be without power when starting the mounting.
  - 7** Insert SIM card (see paragraph 3.1)
  - 8** Connect the required equipment in accordance with paragraph 3.5
  - 9** Connect power supply for the modem (note that there are two variants: either 110/220 VAC or 24 VAC).
  - 10** When the diodes on the GSM Modem 6 stop flashing, the signal strength is read on the indicator [see paragraph 3.4.3]. Mount the external antenna if the signal strength is not at least 12.
  - 11** Before leaving the installation, check the signal strength by SMS (see chapter 6)
- If the module does not indicate normal operation conditions (such as sufficient signal strength), see chapter 5 for error detection help.

## 1.2 Start-up sequence

- 1 Immediately after start-up, all the Signal indicator diodes and the test diode switch on briefly [see Figure 1].
- 2 The two *Signal indicator* diodes at the bottom flash until the module has been initialised correctly (approx. 5 secs. ). When the diode at the bottom stops flashing, the module has been connected to the network (approx. 5-10 secs.).
- 3 Now, the signal indicator will show the current signal level.
- 4 If the module is configured for communication via GPRS, the GPRS diode switches on as soon as the module is connected to the GPRS network (approx. 20 secs. after start-up).
- 5 All diodes will turn off automatically after 10 mins.

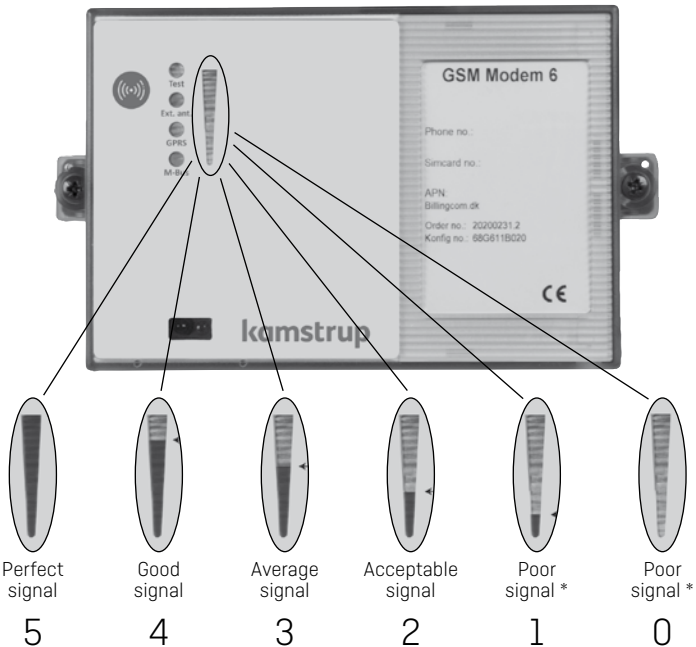

\* Mount external antenna to improve the signal.

**Figure 1**

## 2 Description

### 2.1 Description of GSM Modem 6

GSM Modem 6 is a GSM modem unit of general use. It is designed for meter reading and for special tasks like e.g. controlling relays and receiving input from status inputs. Likewise, it is possible to choose a GSM Modem 6 variant with an integrated M-Bus interface and corresponding data logger.

### 2.2 Technical data

- Dual-band GSM/GPRS modem for meter reading, M-Bus, and standard RS232.
- Standard IP 54 box with integrated 110/230 VAC or 24 VAC power supply.
- Communication up to 9600 bauds.
- Built-in real time clock (RTC) with backup for 10 days.
- 2 serial ports (1 pc. of Kamstrup 3-wire and 1 pc. of RS232/Kamstrup 3-wire).
- 2 relay outputs, 230 VAC, 100 mA, solid state.
- 2 status inputs, potential free, 3.6 VDC in series with 1 M $\Omega$ .
- Signal indicator LEDs for GSM signal strength.
- Push button for GSM signal test.

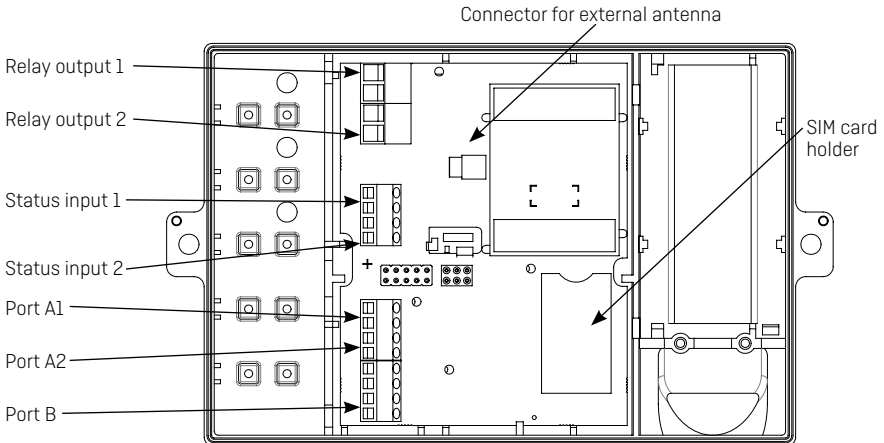

Figure 2

**NOTE: Installation to be carried out by authorized personnel only as it can be highly dangerous to touch connections and internal parts.**

## 3 Installation

### 3.1 SIM card

The unit can be ordered with inserted SIM card on delivery. Check that the card has been inserted. The SIM card phone number appears on a label on the outside of the unit.

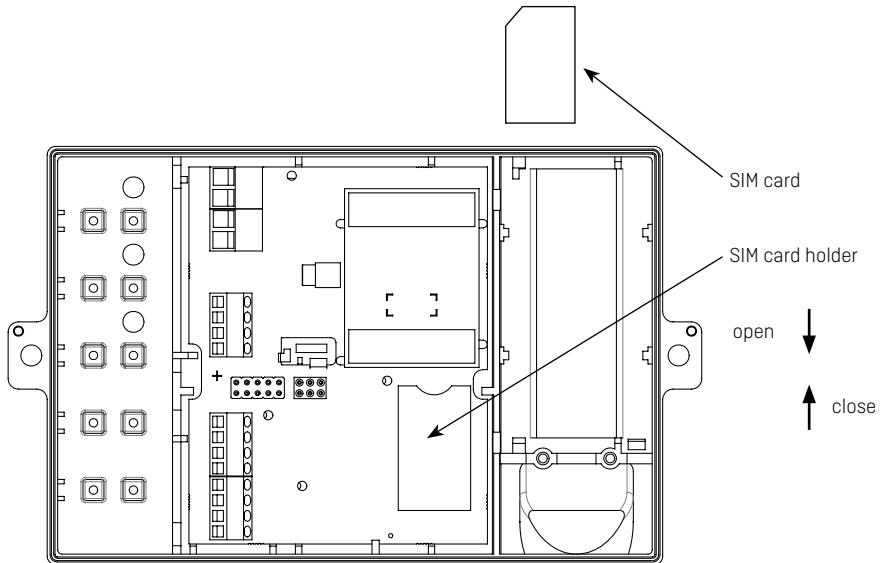

**Figure 3**

Note that Kamstrup A/S cannot be held responsible for theft and misuse of SIM cards from GSM Modem 6 units.

If the unit is supplied without a SIM card, make sure to insert a card before using the unit. Open the SIM card holder by pushing the bright holder in the direction of the arrow towards "Open" and then carefully tipping up the holder. Next, place the SIM card with the "cut-off" corner in the top left side and with the contacts facing the print. At last, tip back the SIM card holder and lock it by pushing the bright holder in the direction of the arrow towards "Lock". Please remember to write the telephone number on a label placed on the outside of the unit.

The SIM card must fulfil the following requirements:

**DATA/SMS-9.6 Kb V110, PIN code must be disabled, no voice and no pre-paid card can be used.  
Please contact your own telecom supplier if you have any questions.**

**When the SIM card holder is opened, the supply to the SIM card is cut off.  
When the SIM card has been inserted correctly and the holder is closed, the module will restart automatically.**

### 3.2 GPRS

#### Set-up:

Kamstrup A/S recommends creating, at the telecom supplier concerned, a closed APN [Access Point Name] which is only accessible via a VPN [Virtual Private Network]. GSM Modem 6 has to use the APN name to log on the APN via GPRS.

In short, following items must be clarified prior to activation:

- APN name (the name of a closed user group)
- VPN connection (tunnel between the GPRS unit and the reading system with data encryption)
- The network of the telecom supplier must be tested by Kamstrup.

If the module is configured for communication via GPRS, the GPRS diode switches on as soon as the module is connected to the GPRS network (approx. 20 secs. after start-up).

Please remember always to contact Kamstrup A/S before ordering GPRS !

### 3.3 Signal test

As an alternative to the signal indicator it is possible to run a signal test in connection with the installation. The signal test states the signal level based on a scale with 32 levels, and consequently it will result in a higher resolution than the signal indicator.

- 1** Activate the push button for approx. 2 secs. [see Figure 4]
- 2** The *TEST* diode now emits light constantly for approx. 10 secs. [see Figure 4], and the signal strength is indicated with flashes on a scale of 0 to 31:
  - a long flash equals 10
  - a short flash equals 1,  
i.e. a signal strength of 14 is indicated by one long flash and 4 short flashes.
- 3** The recommended signal strength is minimum 12.

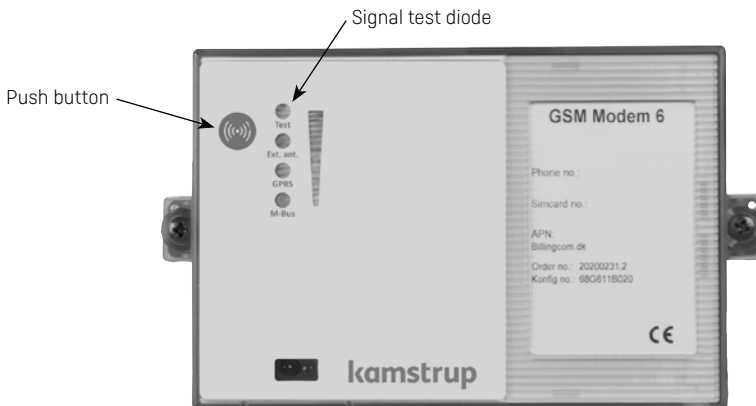

**Figure 4**

**Note that when modems are installed in closed metal cabinets, an external antenna should be mounted because the very moment the cabinet is closed, the signal will be attenuated considerably. Always check the signal strength by sending a =signal# SMS when the cabinet is closed.**

### 3.4 Selecting antenna

#### 3.4.1 Internal antenna

From the factory, GSM Modem 6 is equipped with an internal GSM antenna that is placed in the lid. The internal antenna will be used as default.

In connection with installation it is important to know if the internal antenna is sufficient or if an external antenna should be mounted. To clarify this, the fitter must select the following:

- 1 Mount the lid on GSM Modem 6 and run a signal test as shown in paragraph 3.3.  
If the signal conditions are acceptable, it is not necessary to install an external antenna.
- 2 If the signal conditions are not acceptable, an external antenna should be mounted, see paragraph 3.4.2.

#### 3.4.2 External antenna (to be ordered separately)

Connect the external antenna to the antenna connector on the print, and turn the antenna cable around the connecting piece for correct strain relief, see Figure 5.

Connect the external antenna for optimal antenna conditions.

- 1 Mount the external antenna.
- 2 Mount the lid of GSM Modem 6.
- 3 Press the button twice to tell the modem to use the external antenna.
- 4 The **Ext. Ant** diode starts lightening, and the module restarts automatically (takes approx. 30 secs.).
- 5 Repeat the signal test (see paragraph 3.3) until the optimal location of the antenna has been found.

If you wish to deselect the external antenna again, push the button 3 times. The **Ext. Ant** diode switches off and the module restarts automatically (it takes approx. 30 secs.).

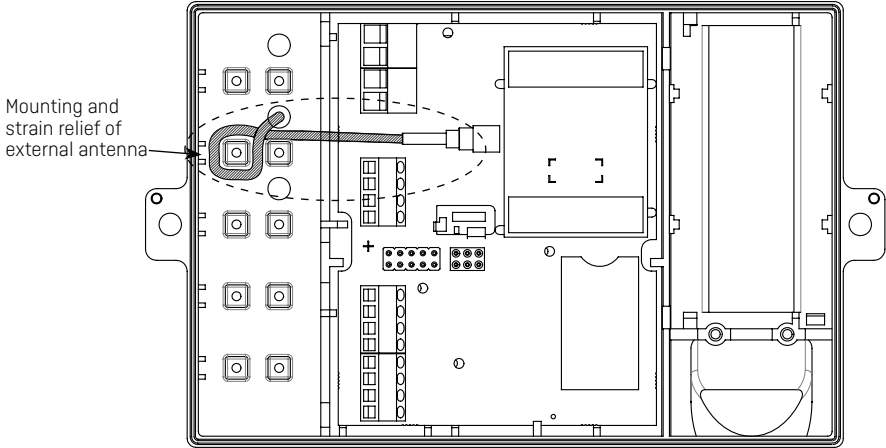

Figure 5

### 3.4.3 Diagram for signal conversion

Signal indicated in dBm	Signal with button test	Signal indicator
-111	1	0
-109	2	0
-107	3	0
-105	4	0
-103	5	0
-101	6	0
-99	7	0
-97	8	0
-95	9	1
-93	10	1
-91	11	1
-89	12	2
-87	13	2
-85	14	2
-83	15	3
-81	16	3
-79	17	3
-77	18	4
-75	19	4
-73	20	4
-71	21	5
-69	22	5
-67	23	5
-65	24	5
-63	25	5
-61	26	5
-59	27	5
-57	28	5
-55	29	5
-53	30	5
-51	31	5

GSM minimum

- *Note: At a signal strength below 12 we cannot guarantee a stable connection to the unit.*
- *The installation must not be handed over before the signal strength is 12 or more. In some cases it might be necessary to mount an external antenna.*
- *If an external antenna is mounted, this must be positioned in a place where it is not shielded, covered, or moved. Nor must it be mounted in closed metal cabinets.*
- *Only use dual-band GSM antennas.*
- *Always complete the installation by sending an SMS [=signal#] to control the signal strength when all doors and cabinets are closed.*

### 3.4.4 Automatic antenna selection

1 hour after the GSM Modem 6 has been set up, it automatically selects antenna. The modem finds the antenna with the best signal (internal or external antenna). From now on, the modem will automatically select antenna every 24 hours.

### 3.5 Light Emitting Diodes (LEDs)

Note that all light emitting diodes automatically turn off after 10 minutes - no buttons have been activated. The light emitting diodes are activated again by running a signal test (see paragraph 3.3)

<b>TEST diode (orange)</b>	<b>Indication of antenna choice (see paragraph 3.4) and signal strength (see paragraph 3.3)</b>
<b>EXT Ant diode (orange)</b>	
LED emits light constantly	External antenna has been selected
LED switched off	Internal antenna has been selected
<b>GPRS diode (orange)</b>	
LED emits light constantly	The modem is connected to the GPRS network
LED switched off	The modem is not connected to the GPRS network, only GSM
<b>M-Bus diode (orange)</b>	
LED turned off	Normal operation
LED flashes	The modem cannot communicate with the unit that is connected via M-Bus

**The diode at the top of the signal indicator flashes when the modem is busy communicating.**

**3.6 Connecting meters and M-Bus Master**

GSM Modem 6 can be connected to and read both electricity meters, heat meters, and M-Bus Master. The meter or M-Bus Master is connected to either port A1 (top) or port B (bottom) via the 3-wire cable which can be delivered together with the GSM unit.

Meters or M-Bus Master are connected as follows:

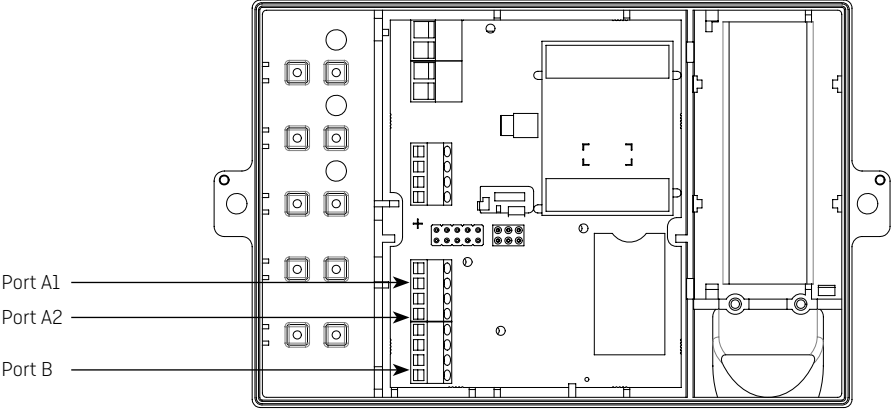

**Figure 6**

Kamstrup 162/382 Kamstrup 351/351 Combi M-Bus Master MULTICAL® RF Concentrator	GSM Modem 6	Electricity meters	
	<b>Port A1 or Port B</b>	Heat meters	
	[Kamstrup RS232]	M-Bus Master and RF Concentrator	
	DATA	62	Brown
	REQ	63	White
	GND	64	Green

P/L precision electricity meter	GSM Modem 6	P/L electricity meter *	
	<b>Port A2</b>		
	[Genuine RS232]		
	Rx	Tx	Brown [23 or 24]
	Tx	Rx	White [24 or 23]
	GND	GND	Green [25]

\* Always check the inside of the terminal cover of the P/L meter as there might be difference between the connections of the different types.

**For the connection of the two P/L precision meters for the same GSM modem, a standard cable must be mounted on port A as described above and a special P/L cable on port B (Order no. 5915097).**

### 3.7 Connecting control relays

We recommend the following relays:

OMRON type G2RS switch relay

Connection, OUT 1 or OUT 2 (see Figure 7 and Figure 8)

#### General information

The relay outputs are of the solid state type and can each be loaded with 24-230 VAC, max 100 mA.

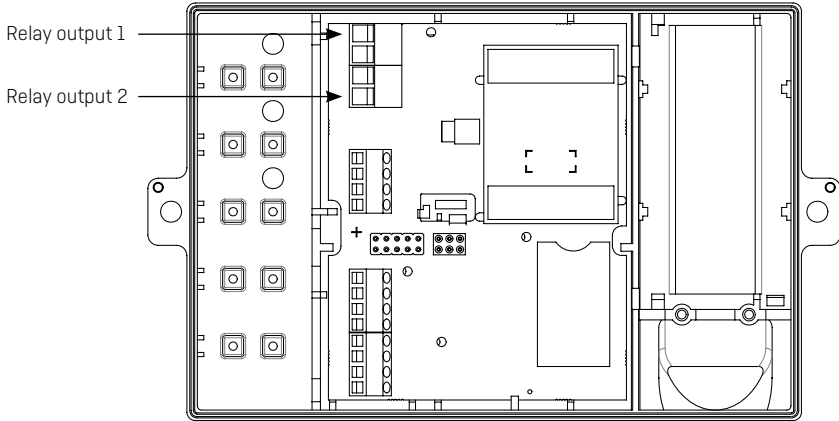

Figure 7

Example of connection between modem and switch relay:

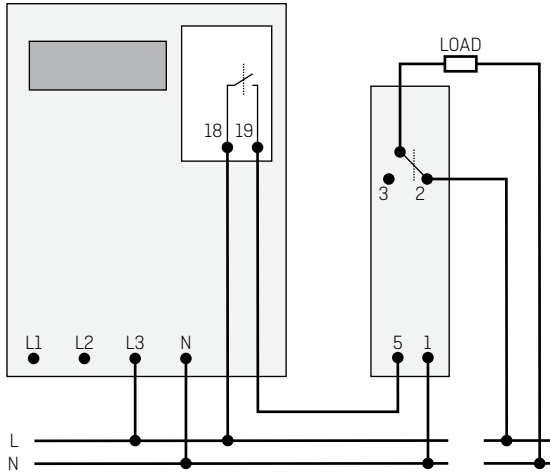

Figure 8

### 3.8 Connecting status inputs

These inputs can be used e.g. as status input from the control relays. The inputs are potential free.

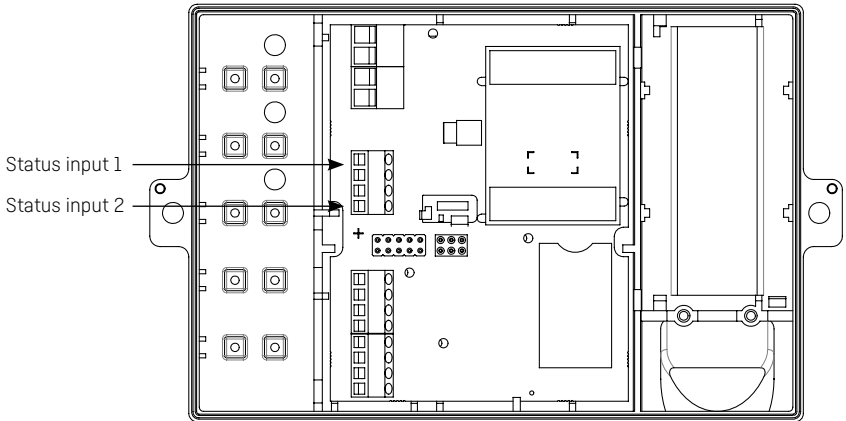

Figure 9

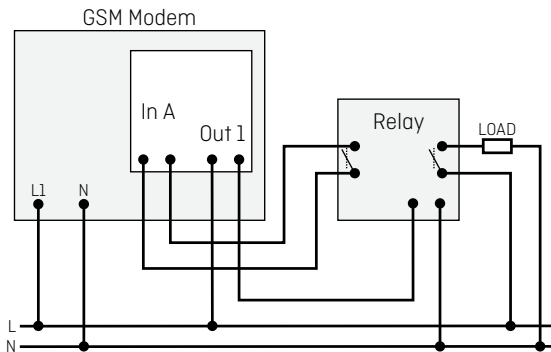

Figure 10

## 4 M-Bus data logger (variant)

GSM Modem 6 can be provided with an M-Bus data logger that can log values via an M-Bus interface. The M-Bus data logger is a top module that is mounted in the lid of GSM Modem 6, and it can be ordered to be mounted at the factory.

Order no.: 68G6X2XXXXXX

This module permits connection and data logging of consumption meters that comply with the M-Bus standard EN13757.

The M-Bus logger reads hourly data and event log from the connected meter and at the same time it functions as supply unit for the M-Bus module in the meter. The M-Bus logger has an integrated RTC (Real Time Clock), providing all data with a time stamp.

The logger's depth is 1080 logs which corresponds to 45 days' hourly data.

It is possible to log the following data (if they are available in the meter):

**Energy – Volume –  $T_{\text{flow}}$  –  $T_{\text{return}}$  – Delta T – Power - Flow**

### 4.1 Connecting M-Bus unit

The two units are connected with the enclosed two-wire cable. On the front plate of GSM Modem 6 it is possible immediately to see if communication between the two units is accomplished without problems since the M-Bus diode will flash quickly in the case of errors.

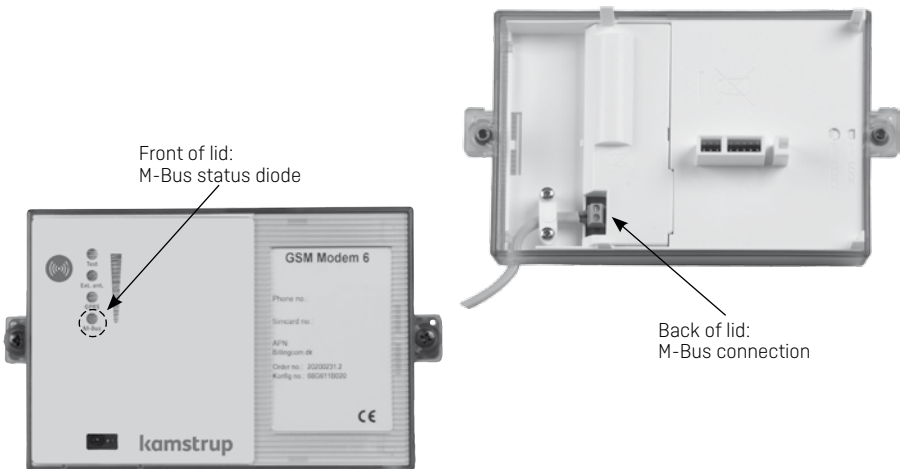

## 5 Error Detection Help

**NOTE:** All light emitting diodes will turn off automatically after 10 minutes. They can be reactivated for another 10 minutes by pressing the push button.

The diodes emit no light.	Check that there is supply voltage. Activate the push button to see if the light emitting diodes switch on, see paragraph 3.5
The modem will not run the signal test.	Make sure that a SIM card has been mounted and that it is facing the right direction. Check that the SIM card complies with the specifications, see paragraph 3.4.2.
The signal strength is not good enough.	Mount an external antenna, which can be ordered at Kamstrup A/S, see paragraph 3.1
The signal strength will not improve after mounting an external antenna.	<ul style="list-style-type: none"> <li>• Make sure that <b>Ext.ant.</b> has been selected on the front of the modem by means of the push button, see paragraph 3.4.2.</li> <li>• Place the antenna in different places to find the location with the best signal strength, see paragraph 3.4.3</li> <li>• Make sure that the antenna connector has been mounted correctly and that it "clicked" when it was inserted.</li> <li>• Check that the antenna that is used is a GSM dual-band 900/1800 MHz antenna.</li> <li>• On special occasions it might be necessary to mount the antenna far away from the modem or outside the building to obtain good signal strength.</li> </ul>
The signal strength has become worse since the moment of installation.	<ul style="list-style-type: none"> <li>• If the modem has been mounted in a closed metal cabinet, an external antenna must be mounted outside the cabinet. Otherwise, the signal strength will be attenuated.</li> <li>• Check if any changes have been made in the environment surrounding the modem (a fire door has been closed, the antenna has been moved or covered, etc.).</li> <li>• Ask the telecom supplier if any changes have been made to the coverage or if there are any operational problems in the local area.</li> </ul>
The GPRS diode does not emit light.	<p>The modem is not connecting to the GPRS network.</p> <ul style="list-style-type: none"> <li>• The modem is only connecting to GPRS if this has been ordered and it has a valid APN name, see paragraph 3.2</li> <li>• Check that the SIM card supports GPRS, ask the telecom supplier.</li> </ul>
The M-Bus diode flashes.	The connected unit has not been installed correctly or does not comply with the EN13757 standard. Please contact Kamstrup to obtain an updated list of supported meters.
Defective modem	Enclose a precise description of the error and return the modem to Kamstrup.

## 6 SMS commands

**NOTE:** SMS commands must be sent in either capital or small letters.  
Capital and small letters must not be mixed in the same SMS command.

### SIGNAL - for reading the signal strength

Syntax, command	=SIGNAL#
Syntax, return answer	Signal: <signal strength> [0-31]
Example	=SIGNAL#
Return answer, correct	Signal: 14 [0-31]
Current signal strength is 14	
Return answer, error	NO RESPONSE

### CONTROL\_OUTPUT - to the control of relay outputs

Syntax	=CONTROL_OUTPUT <out1> <out2>#
Example 1	=CONTROL_OUTPUT 1 1#
Connect both relays immediately	
Example 2	=CONTROL_OUTPUT 1 0#
Switch on relay 1 and switch off relay 2 immediately	
Return answer, correct	NO RESPONSE
Return answer, error	NO RESPONSE

### IOSTATUS - for reading of status of relay outputs and status/alarm inputs

Syntax	=IOSTATUS#
Syntax, return answer	Relay1: <status> Relay2: <status> Input1: <status> Input2: <status>
Example	=IOSTATUS#
Return answer, correct	Relay1: 1 Relay2: 0 Input1: 1 Input2: 0
Return answer, error	NO RESPONSE

<b>READ_HEAT_METER – For reading MULTICAL® 601 and MULTICAL® 801</b>	
Syntax	=READ_HEAT_METER <port>#
Example 1 Reads meter on either <b>Port A</b> or <b>Port B</b>	=READ_HEAT_METER#
Example 2 Reads meter on <b>Port A</b>	=READ_HEAT_METER A#
Example 3 Reads meter on <b>Port B</b>	=READ_HEAT_METER B#
Response, correct The following values are read: Acc. energy: [KWh], [MWh], [GJ] or [GCal] Current power: [kW] or [MW] Acc. water consumption: [m <sup>3</sup> ] Current water consumption: [l/h] or [m <sup>3</sup> /h] Meter number: Temperature: [C] Info code: Hour counter:	114931.6 MWh, 25.99 MW, 1657074 m <sup>3</sup> 379.8 m <sup>3</sup> /h, Meter No.: 5300279, T1: 93.15 C, T2: 32.00 C, Info code: 0, 7373 Hours
Return response, meter error	No meter response
Return response, command error	NO RESPONSE

<b>READ_WATER_METER – For reading MULTICAL® 61</b>	
Syntax	=READ_WATER_METER <port>#
Example 1 Reads meter on either <b>Port A</b> or <b>Port B</b>	=READ_WATER_METER#
Example 2 Reads meter on <b>Port A</b>	=READ_WATER_METER A#
Example 3 Reads meter on <b>Port B</b>	=READ_WATER_METER B#
Response, correct The following values are read: Acc. water consumption: [m <sup>3</sup> ] Current water consumption: [l/h] or [m <sup>3</sup> /h] Meter number: Info code: Hour counter:	710.82 m <sup>3</sup> , 1476 l h Meter No.: 6480703, Info code: 0, 481 Hours
Return response, meter error	No meter response
Return response, command error	NO RESPONSE

<b>READ_PRESSURE – For reading MULTICAL® 801 or MULTICAL® 601</b>	
Syntax	=READ_PRESSURE <port>#
Example 1 Reads meter on either <b>Port A</b> or <b>Port B</b>	=READ_PRESSURE#
Example 2 Reads meter on <b>Port A</b>	=READ_PRESSURE A#
Example 3 Reads meter on <b>Port B</b>	=READ_PRESSURE B#
Response, correct The following values are read: Pressure: [bar] Meter number:	2.34 bar, 2.23 bar, Meter No.: 6349933
Return response, meter error	No meter response
Return response, command error	NO RESPONSE

## 7 GSM Modem 6 Variant structure

68G6 -

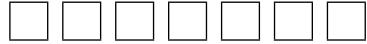

### Power supply

110 VAC/230 VAC.....	1
24 VAC.....	2

### Function

GSM6 standard .....	1
GSM6 with M-Bus logger .....	2

### Software variants

Standard.....	A
EVL.....	B

### Features

None .....	A
Earth fault .....	B

### Communication cable mounted on port A

None .....	0
Kamstrup 3-wire.....	1
RS232 .....	2

### Communication cable mounted on port B

None .....	0
Kamstrup 3-wire.....	1
P/L cable .....	2

### Country code

Other countries .....	00
DK .....	10
N.....	40
S.....	90

**Accessories:**

**SIM card**

None	0
BillingCom (country dependent)	1
SIM card supplied by the customer	3

**Fitting for mounting**

None	0
DIN	1
Standard MC	2

**Antenna**

No external antenna	1
External antenna, Triangle 1.5 m cable (6699407)	2
External antenna, Triangle x m cable (6699408)	3
External antenna, Dual-band disc 1 m cable (6699458)	4
Antenna adapter MCX to SMA (5000292)	5
Antenna adapter MCX to FME (5000291)	6
Mini Triangle antenna (6699448)	7



