

Data sheet

**ULTRAFLOW® 54  
DN150-300**

- Ultrasonic flow sensor ( $q_p$  150...1000 m<sup>3</sup>/h)
- Static sensor, no moving parts and no wear
- Compact design
- Configurable
- Small pressure loss
- Large dynamic range
- Exceptionally accurate
- Durable

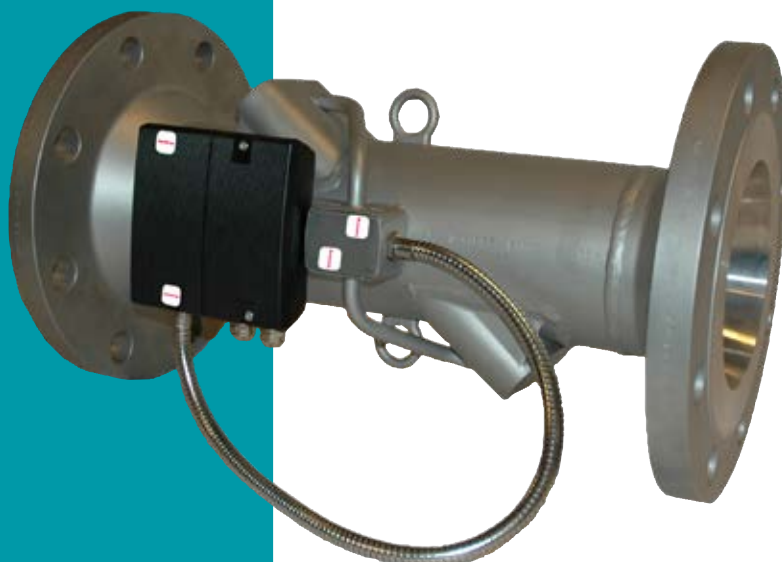

MID 2014/32/EU



EN 1434

DK-BEK 1178 – 06/11/2014



EN 1434

## Contents

---

Description	2
Compliance	3
Technical data	4
Flow data	5
Materials	6
Type summary	6
Dimensional sketches	7
Pressure loss	8
Installation	9
Straight inlet ULTRAFLOW® 54	10
Operating pressure	10
Connection to calculator	10
Type numbers of ULTRAFLOW® 54 for MULTICAL®	12
Type numbers for separate ULTRAFLOW® 54	12
Type number composition of separate ULTRAFLOW® 54	13
Type numbers of output and supply modules	13
Programming variants of meter factor and pulse duration	14
Accessories	15

## Description

---

ULTRAFLOW® 54 is a static flow sensor based on the ultrasonic measuring principle. It is used primarily as a subassembly of a thermal energy meter in combination with the separate calculators MULTICAL® 603 or MULTICAL® 803 and a set of TemperatureSensor 63 & 83. ULTRAFLOW® 54 has been designed for use in heat and cooling installations where water is used as the heat-bearing medium.

ULTRAFLOW® 54 employs microprocessor technology. The flow is measured using bidirectional ultrasonic technique based on the transit time method. All circuits for calculating and measuring are collected on a single board, providing a compact and rational design in addition to an exceptionally high level of measuring accuracy and proven long-term stability.

A three-wire signal cable is used to connect ULTRAFLOW® 54 to the separate MULTICAL® calculators. This cable is used to supply the flow sensor from the calculator and also to send the volume-proportional pulses to the calculator.

If ULTRAFLOW® 54 is used as a flow sensor for other equipment, it should be configured with a galvanically isolated pulse output module. If ULTRAFLOW® is connected to another calculator with a different meter factor than the one supplied by ULTRAFLOW®, meter factor and pulse duration can easily be configured. With a suitable configuration of ULTRAFLOW® 54 from the factory or a reconfiguration on site, installations with cable lengths of up to 100 m to MULTICAL® can be realized. In all cases, ULTRAFLOW® 54 uses a built-in supply. Alternatively, a Cable Extender Box can be used for this purpose for cable lengths of up to 30 m between ULTRAFLOW® 54 and MULTICAL®.

## Compliance

---

### Type approval

ULTRAFLOW® 54 is approved as a heat meter in accordance with MID 2014/32/EU:

EU-Type Examination certificate	DK-0200-MI004-008
MID-certified according to Module D	DK-0200-MID-D-001



ULTRAFLOW® 54 is approved as a cooling meter in accordance with DK-BEK 1178 – 06/11/2014:

System designation	TS 27.02 002
Verification	DANAK accreditation 268



Please contact Kamstrup A/S for further information relating to type approval and verification.

### Standards and documents

EN 1434:2007/AC2007  
 EN 1434:2015+A1:2015  
 EN 1434:2022  
 WELMEC 7.2:2021

### CE-marking

ULTRAFLOW® 54 is marked in accordance with:

– EMC-directive	2014/30/EU
– LV-directive	2014/35/EU (when fitted with 230 VAC power supply)
– PE-directive	2014/68/EU (category II)

### Approved meter data

MID designation

– Mechanical environment	M1 (vibrations and shocks of low significance) M2 (significant or high levels of vibrations and shocks)
– Electromagnetic environment	E1 (residential, commercial and light industrial buildings) E2 (other industrial buildings)
– Climatic environment	5...55 °C, condensing, closed location (indoors installation)
– Accuracy class	2 and 3

EN 1434 designation

– Environmental class	C (high electrical and electromagnetic conditions)
– Fast response meter	Volume sampling interval ≤ 1 s (sub-assembly flow sensor)

## Technical data

---

### Electrical data

Internal supply voltage	3.6 VDC ± 0.1 VDC
Supply, galvanically coupled output module (Y=1)	Powered by MULTICAL®
Supply, galvanically separated output module (Y=2) *	
- Mains supply	230 VAC +15/-30 %, 50 Hz or 60 Hz 24 VAC ±50 %, 50 Hz or 60 Hz
- Power consumption	< 1 W
- Backup	Integral SuperCap eliminates interruptions due to short-term power failures
Supply, galvanically separated output module (Y=3)	
- Battery	3.65 VDC, D-cell lithium
- Life time (replacement interval)	6-years @ $t_{BAT} < 30 \text{ °C}$
- Mains supply	230 VAC +15/-30 %, 50 Hz or 60 Hz 24 VAC ±50 %, 50 Hz or 60 Hz
- Power consumption	< 1 W
- Backup	Integral SuperCap eliminates interruptions due to short-term power failures
Length of pulse cable, flow sensor electronics box	
- Galvanically coupled output module (Y=1)	Max 10 m (powered by MULTICAL® calculator) Max 30 m via Cable Extender Box (powered by MULTICAL® calculator)
- Galvanically separated output module (Y=2 and Y=3)	Depending on the calculator, the connection and the output module. For Y = 2 in two-wire connection with additional 24 VAC supply, max 100 m to MULTICAL®.
Electromagnetic environment	Fulfils EN 1434 class C, MID E1 and E2
* It is possible to use battery supply in combination with output module (Y=2), but with limited battery lifetime. Suitable e.g. as temporary supply of flow sensors installed at construction sites.	

## Technical data

### Mechanical data

Accuracy class	2 and 3
Electromagnetic environment	Fulfils EN 1434 class C, MID E1 and E2
Mechanical environment	MID M1 and M2
Ambient conditions	5...55 °C, closed location (installation indoors)
Protection class *	IP67
Medium in flow sensor	Water – recommended water quality as in CEN TR 16911 and AGFW FW510
Medium temperature	2...150 °C or narrower range
Storage temperature (empty sensor)	-25...60 °C
Pressure stage	PN16, PS16 (DN300) PN25, PS25 (DN150-250)

At medium temperatures above 90 °C or below the ambient temperature the electronics box must not be mounted on the flow sensor. Instead mounting with the enclosed bracket is recommended

\* The flow sensor's IP class is limited by the electronic housing, which can be separated from the flow sensor via the enclosed bracket. The body of the flow sensor is durable, even in permanently wet conditions.

## Flow data

Nom. flow $q_p$ [m <sup>3</sup> /h]	Nom. diameter [mm]	Meter factor *	Dynamic range $q_p:q_i$	$q_s:q_p$	Flow @125 Hz ** [m <sup>3</sup> /h]	$\Delta p@q_p$ [bar]	Min. cut-off [m <sup>3</sup> /h]
150	DN150	1	100:1	2:1	450	0.02	0.75
250	DN150	0.6	100:1	2:1	750	0.055	1.25
400	DN150	0.4	100:1	2:1	1125	0.04	2
400	DN200	0.4	100:1	2:1	1125	0.01	2
400	DN250	0.4	100:1	2:1	1125	0.01	2
600	DN200	0.25	100:1	2:1	1800	0.022	3
600	DN250	0.25	100:1	2:1	1800	0.022	3
1000	DN250	0.15	100:1	2:1	3000	0.015	5
1000	DN300	0.15	100:1	2:1	3000	0.015	5

\* Default value. The meter factor appears from the ULTRAFLOW® label.

\*\* Saturation flow 125 Hz. Max. pulse frequency is maintained at higher flow rates.

## Materials

---

### Wetted parts

Housing	Stainless steel, W.no. 1.4301
Transducer holder	Stainless steel, W.no. 1.4308
Transducer	Titanium
Gaskets	Fibre

### Electronics box

Base	Thermoplastic, PC 10 % GF
Cover	Thermoplastic, PC 10 % GF
Fitting hardware and bracket for the electronic box	Thermoplastic, PPS 40 % GF

**Signal cable** Silicone cable (3 x 0.5 mm<sup>2</sup>)

**Power supply cable 24/230 VAC** Cable with PVC mantle (2 x 0.75 mm<sup>2</sup>)  
[optional]

## Type summary

---

Nom. flow $q_p$ [m <sup>3</sup> /h]	Installation dimensions		
	DN150 x 500 mm	DN200 x 500 mm	DN250 x 600 mm
150	DN150 x 500 mm		
250	DN150 x 500 mm		
400	DN150 x 500 mm	DN200 x 500 mm	DN250 x 600 mm
600	DN200 x 500 mm	DN250 x 600 mm	
1000	DN250 x 600 mm	DN300 x 500 mm	

Flange facing type B, raised face according to EN 1092-1

### Dimensional sketches

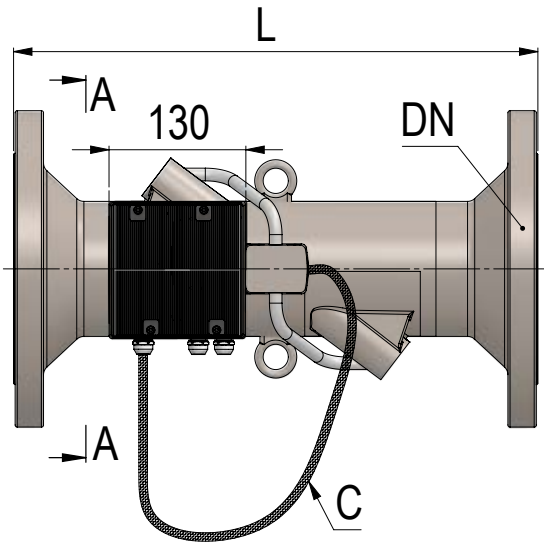

### Flange facing type B, raised face according to EN 1092-1

Nom. diameter [mm]	PN [bar]	Nom. flow $q_p$ [m <sup>3</sup> /h]	L [mm]	D [mm]	k [mm]	Bolts			B1 [mm]	E [mm]	Steel tube length C [mm]	Approx. weight [kg]
						Quantity	Thread [mm]	$d_2$ [mm]				
DN150	25	150 & 250	500	300	250	8	M24	26	119	282	650	37
DN150	25	400	500	300	250	8	M24	26	140	303	625	36
DN200	25	400 & 600	500	360	310	12	M24	26	166	329	570	49
DN250	25	400 & 600	600	425	370	12	M27	30	166	329	570	79
DN250	25	1000	600	425	370	12	M27	30	194	357	500	75
DN300	16	1000	500	460	410	12	M24	26	194	357	500	76

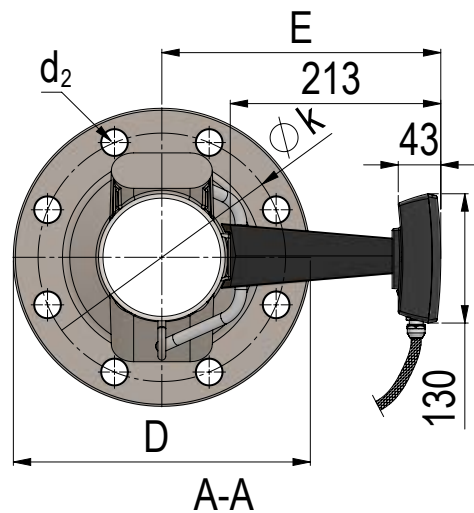
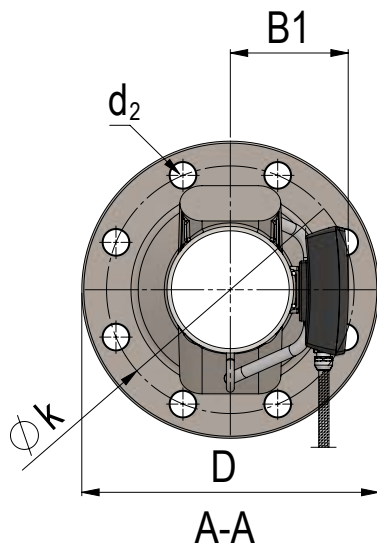

## Pressure loss

Graph	Nominal flow $q_p$ [m³/h]	Nominal diameter [mm]	$k_v^*$	$q@0.25\text{ bar}$ [m³/h]
A	150 & 250	DN150	1060	530
B	400	DN150	2000	1000
C	400 & 600	DN200 & DN250	4040	2020
D	1000	DN250 & DN300	8160	4080

\*  $q = k_v \times \sqrt{\Delta p}$

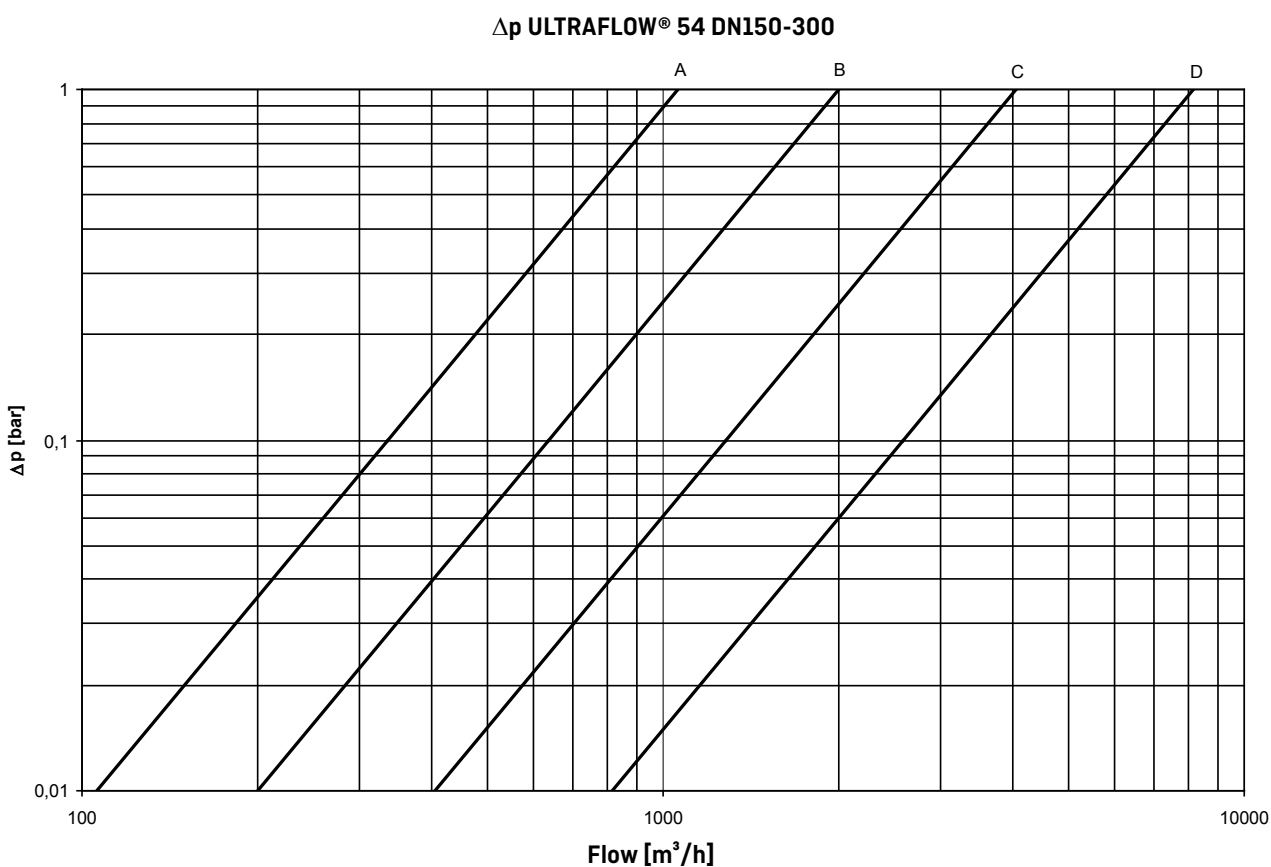

## Installation

⚠ Please read this chapter carefully before installing the meter.

In case of incorrect mounting, Kamstrup's guarantee obligations no longer apply.

By connecting to 230 V supply, there is a risk of electric shock.

When working on the flow sensor in the installation, there is a risk of outflow of [hot] water under pressure.

At a media temperature higher than 60 °C, the flow sensor should be shielded from unintended contact.

Prior to installation of the flow sensor, the system should be flushed.

Correct flow sensor position (inlet or outlet) appears from the front label of MULTICAL®. The flow direction is indicated by an arrow on the flow sensor.

⚠ ULTRAFLOW® 54 may be lifted in the lifting rings only.

**Pressure stage:** PN16, PS16/PN25, PS25. See marking on label.

**Temperature of medium:** 2...150 °C/2...130 °C/2...50 °C. See marking on label.

**Mechanical environment:** M1 and M2 (fixed installation with minimum vibration and fixed installation with considerable or high vibration level respectively). See marking on label.

**Electromagnetic environment:** E1 and E2 (housing/light industry and industry respectively). See marking on label.

The meter's signal cables must be drawn at min. 25 cm distance to other installations.

**Ambient conditions:** The ambient temperature must be within 5...55 °C. Installation must be in closed locations (indoors).

**Protection class:** IP67 – The flow sensor's IP class is limited by the electronic housing, which can be separated from the flow sensor via the enclosed bracket. The body of the flow sensor is durable, even in permanently wet conditions.

**Insulation:** ULTRAFLOW® 54 can be insulated. For details see Insulation manual 5512-2376-GB, which can be downloaded from [www.kamstrup.com](http://www.kamstrup.com).

**Maintenance and repair:** The flow sensor is verified separately and can, therefore, be separated from the calculator. It is permitted to replace the supply and change the supply type. For battery supply a lithium battery with connector from Kamstrup A/S must be used. Lithium batteries must be correctly handled and disposed of (see Kamstrup document 5510-408, "Lithium batteries - Handling and disposal"). Other repairs require subsequent reverification in an accredited laboratory.

If ULTRAFLOW® 54 is connected via a galvanically coupled output module, the flow sensor may be connected to a Kamstrup MULTICAL® calculator only.

If other calculator types are connected, ULTRAFLOW® 54 must be fitted with a galvanically separated output module and a power supply of its own.

⚠ Make sure that meter factor of flow sensor and calculator are identical.

The steel tube between flow sensor housing and electronics box must not be disassembled.

At medium temperatures above 90 °C or below ambient temperature the flow sensor's electronics box must be mounted via the enclosed bracket. Alternatively, the electronics box can be wall-mounted at a distance of minimum 170 mm from the sensor.

When the installation has been completed, water flow can be turned on. The valve on the inlet side must be opened first.

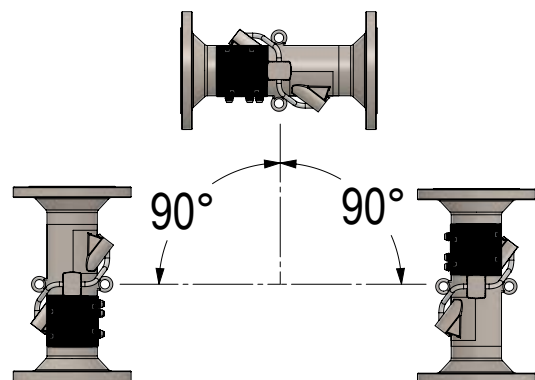

### Installation angle of ULTRAFLOW® 54

ULTRAFLOW® 54 can be installed horizontally, vertically, or at an angle.

ULTRAFLOW® 54 is normally installed horizontally, with the lifting rings oriented vertically. The ultrasound paths in the flow sensor tube will thus be vertical, which is optimal in connection with possible stratification of the medium.



## Connection to calculator

### ULTRAFLOW® 54 and MULTICAL®, galvanically separated

If ULTRAFLOW® 54 and MULTICAL® are connected via output module (Y=2 or 3), ULTRAFLOW® 54 is galvanically separated from MULTICAL®.

Maximum cable length depends on calculator.

⚠ Flow info cannot be read.

### Three-wire connection

MULTICAL® 602/603/801/803 via output module (Y=2 or 3).

Cable length < 10 m.

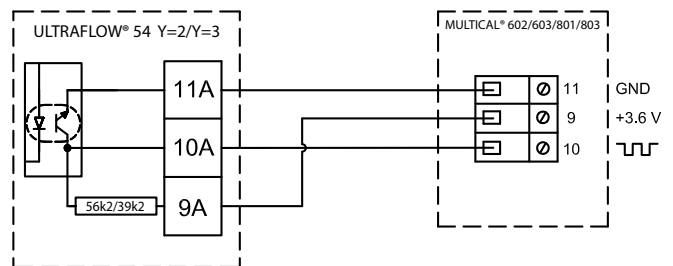

### Two-wire connection

MULTICAL® 602-D/603-G via output module (Y=2) and external 24 VDC supply.

Cable length < 100 m.

(PCB 6699614 only relevant for MULTICAL® 602)

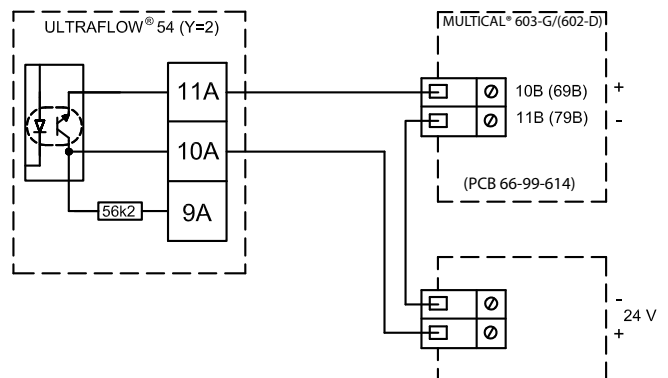

### Two-wire connection

MULTICAL® 803 via output module (Y=2).

Note the auxiliary supply in MULTICAL® 803 via PCB 66-99-045.

Cable length < 100 m.

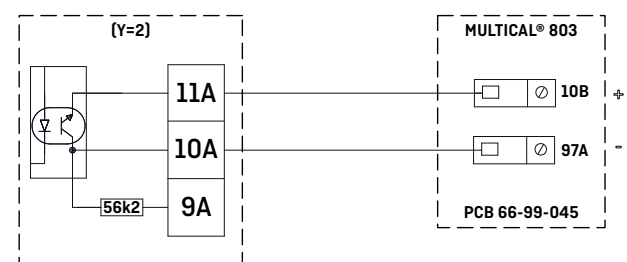

If long signal cables are used, please consider the installation carefully. There must be **at least 25 cm** between the signal cable and all other cables due to EMC.

## Type numbers of ULTRAFLOW® 54 for MULTICAL®

Type number *	Nom. flow $q_p$ [m <sup>3</sup> /h]	Min. flow $q_i$ [m <sup>3</sup> /h]	Max. flow $q_s$ [m <sup>3</sup> /h]	Connection	PN [bar]	Length [mm]	Meter factor [p/l]	Material (housing)
65-5-FCCN-XXX	150	1.5	300	DN150	25	500	1	Stainless steel
65-5-FDCN-XXX	250	2.5	500	DN150	25	500	0.6	Stainless steel
65-5-FECN-XXX	400	4.0	800	DN150	25	500	0.4	Stainless steel
65-5-FECP-XXX	400	4.0	800	DN200	25	500	0.4	Stainless steel
65-5-FECP-XXX	400	4.0	800	DN250	25	600	0.4	Stainless steel
65-5-FFCP-XXX	600	6.0	1200	DN200	25	500	0.25	Stainless steel
65-5-FFCR-XXX	600	6.0	1200	DN250	25	600	0.25	Stainless steel
65-5-FGCR-XXX	1000	10.0	2000	DN250	25	600	0.15	Stainless steel
65-5-FGDS-XXX	1000	10.0	2000	DN300	16	500	0.15	Stainless steel

\* XXX-code pertaining to final assembly, approvals etc. is determined by Kamstrup A/S. Some variants may not be available in national approvals.

## Type numbers for separate ULTRAFLOW® 54

Type number *	Nom. flow $q_p$ [m <sup>3</sup> /h]	Min. flow $q_i$ [m <sup>3</sup> /h]	Max. flow $q_s$ [m <sup>3</sup> /h]	Connection	PN [bar]	Length [mm]	Material (housing)
65-5-FCCN-YZ-XXX	150	1.5	300	DN150	25	500	Stainless steel
65-5-FDCN-YZ-XXX	250	2.5	500	DN150	25	500	Stainless steel
65-5-FECN-YZ-XXX	400	4.0	800	DN150	25	500	Stainless steel
65-5-FECP-YZ-XXX	400	4.0	800	DN200	25	500	Stainless steel
65-5-FECP-YZ-XXX	400	4.0	800	DN250	25	600	Stainless steel
65-5-FFCP-YZ-XXX	600	6.0	1200	DN200	25	500	Stainless steel
65-5-FFCR-YZ-XXX	600	6.0	1200	DN250	25	600	Stainless steel
65-5-FGCR-YZ-XXX	1000	10.0	2000	DN250	25	600	Stainless steel
65-5-FGDS-YZ-XXX	1000	10.0	2000	DN300	16	500	Stainless steel

\* XXX-code pertaining to final assembly, approvals etc. is determined by Kamstrup A/S. Some variants may not be available in national approvals. The meter factor is programmable.



## Programming variants of meter factor and pulse duration

Overview of programming variants of meter factor (CC) and pulse durations (E) for separate ULTRAFLOW® 54.

q <sub>p</sub> [m <sup>3</sup> /h]	Meter factor			Pulse duration				
	[p/l]	[l/p]	CC	[ms] (E=1)	[ms] (E=4)	[ms] (E=5)	[ms] (E=6)	
150	1		33	3.9	-	-	-	Default
150		10	34	-	20	-	-	
150		25	64	-	20	-	-	
150		100	35	-	20	50	100	
150		250	65	-	20	50	100	
150		1000	36	-	20	50	100	
150		2500	66	-	20	50	100	
250	0.6		43	3.9	-	-	-	Default
250		10	34	-	20	-	-	
250		25	64	-	20	-	-	
250		100	35	-	20	50	100	
250		250	65	-	20	50	100	
250		1000	36	-	20	50	100	
250		2500	66	-	20	50	100	
400	0.4		63	3.9	-	-	-	Default
400		100	35	-	20	50	-	
400		250	65	-	20	50	100	
400		1000	36	-	20	50	100	
400		2500	66	-	20	50	100	
600	0.25		14	3.9	-	-	-	Default
600		100	35	-	20	50	-	
600		250	65	-	20	50	-	
600		1000	36	-	20	50	100	
600		2500	66	-	20	50	100	
1000	0.15		24	3.9	-	-	-	Default
1000	[0.25]	4	14	3.9	-	-	-	*)
1000		100	35	-	20	50	-	
1000		250	65	-	20	50	-	
1000		1000	36	-	20	50	100	
1000		2500	66	-	20	50	100	

\* Spare part for ULTRAFLOW® type 65-S/R/T q<sub>p</sub> 1000. Configured 65-5-FGCR. No flow info.

## Accessories

---

### Description

### Type number

#### Flange gaskets

DN150, PN25 (1 pc.)	1150-140
DN200, PN25 (1 pc.)	1150-139
DN250, PN25 (1 pc.)	1150-141
DN300, PN16 (1 pc.)	1150-164

#### Supply

D-cell lithium battery with two-pole connector	65000000-2000
230 VAC supply module	65000000-7000
24 VAC supply module	65000000-8000

#### Output modules

Output module (Y = 1), galvanically connected	66-99-011
Output module (Y = 2), galvanically separated	66-99-012
Output module (Y = 3), galvanically separated, "Low power"	66-99-013

#### Cables

ULTRAFLOW® 54 DN150-300, when ordered with MULTICAL®, is delivered with 2.5 m signal cable, optionally 5 or 10 m. The cable is mounted in the ULTRAFLOW® 54 electronics box and in MULTICAL® 603.

When ULTRAFLOW® 54 is ordered with MULTICAL® 803, the calculator is delivered in a separate box. Hence the cable is only mounted in the ULTRAFLOW® 54 electronics box.

ULTRAFLOW® 54 DN150-300, when ordered as a separate flow sensor, is also optionally available with signal cable in lengths of 2.5, 5 or 10 m. The cable is mounted in the flow sensor's electronics box.

If in addition a 24/230 VAC supply module is selected, the sensor is optionally available with power supply cable. The cable is mounted in the flow sensor's electronics box from the factory.

24/230 VAC power cable	5000-286
2.5 m silicone cable (3 wire)	5000-333
5 m silicone cable (3 wire)	5000-259
10 m silicone cable (3 wire)	5000-270

#### Miscellaneous

Short bracket	6561-332
Long bracket	3026-507
Wall bracket including mounting kit	3026-207.A
Strap for long bracket	1051-006
Cable Extender Box	6699-036

ULTRAFLOW® 54 DN150-300

Kamstrup A/S • FILE100001801\_C\_EN-5810895\_M1\_10.2023

---

**Kamstrup A/S**

Industrivej 28, Stilling  
DK-8660 Skanderborg  
T: +45 89 93 10 00  
info@kamstrup.com  
kamstrup.com