

Installation and User Guide for **SVM S6 & ULTRAFLOW®**



Kamstrup

www.kamstrup.com

MID designations

Permissible operating conditions/measuring ranges:

Calculator θ : 2°C...180°C $\Delta\theta$: 3K...170K

Temperature sensor pair θ : 10°C...150°C $\Delta\theta$: 3K...140K

Flow sensors θ : 15°C...130°C

Mechanical environment:

M1 (fixed installation with minimum vibrations).

Electromagnetic environment:

E1 and E2 (housing, light industry and industry). The meter's control cables must be drawn at min. 25 cm distance to other installations.

Climatic environment:

Must be installed in non-condensing environment as well as in closed location (indoors).

The ambient temperature must be within 5...55°C.

Maintenance and repair:

The district heating supplier can replace communication module, battery, temperature sensor pair and flow sensor. The flow sensor is verified separately and can, therefore, be separated from the calculator. Other repairs require subsequent reverification in an accredited laboratory.

SVM S6, type S6-B/C/D must be used with temperature sensor pair type Pt500.

SVM S6, type S6-A must be used with temperature sensor pair type Pt100.

Battery for replacement: Kamstrup type 66-00-200-100.

SVM S6, type S6-A/B/C can be connected to flow sensor type ULTRAFLOW®, electronic pick-up, or flow sensors with reed switch.

SVM S6, type S6-D must be connected to a flow sensor with 24 V active pulse output.

Irrespective of flow sensor type, "pulses/litre" must be identical in flow sensor and calculator.

SVM S6 & ULTRAFLOW®

English



Kamstrup

Kamstrup AB
Enhagssligan 2, S-187 40 Täby
Tel: +46-8-522 265 00 · Fax: +46-8-522 265 08
info@kamstrup.com · www.kamstrup.com

Contents

General information	4
Mounting of temperature sensors	4
Pocket sensor pair	4
Short direct temperature sensor pair	5
Mounting of flow sensor	5
Mounting ULTRAFLOW® ≤ DN100	6
Mounting ULTRAFLOW® 54 ≥ DN150	7
Installation examples	7
Humidity and condensation	7
Electrical connection of SVM S6 and ULTRAFLOW®	8
Connection example	8
Heat meters with two flow sensors	9
Mounting of calculator	10
Compact mounting	10
Separate/wall mounting	10
Panel mounting	10
Voltage supply of calculator/Pulse Transmitter	10
Battery supply	10
Mains modules	11
High-power supply modules	11
Isolated linear supply modules	11
Testing of function	11
Information codes “INFO”	12
Plug-in modules	13
Base modules	13
Data/pulse input, type 67-00-10	13
M-Bus, type 67-00-20/27/28	13
Radio/pulse inputs, type 67-00-25/26	14
Prog. data logger + RTC + 4...20 mA input + pulse input, type 67-00-22	14
Analog outputs, type 67-00-23	14
Lon Works, type 67-00-24	14
Wireless M-Bus, type 67-00-30, 602-00-035	14
ZigBee + pulse input, type 67-00-60	15
Metasys N2 + pulse input, type 67-00-62	15
SIOX module (Auto detect Baud rate), type 602-00-64	15
GSM/GPRS module (GSM6H), type 602-00-80	15
Ethernet/IP module (IP201), type 602-00-82	15
High-Power RadioRouter + 2 pulse inputs (VA, VB), type 602-00-84	16
Top modules	16
Electrical connection of SVM S6, ULTRAFLOW® and Pulse Transmitter	18
Setup via front keys	19

1. General information

⚠ Read this guide before installing the energy meter.

Kamstrup's guarantee obligations do not apply in case of incorrect mounting. Please note that the following installation conditions must be obeyed:

- Pressure stage ULTRAFLOW®: PN16/PN25/PN40, see marking. Flow sensor marking does not apply to encl. accessories.
- Pressure stage Kamstrup sensor pair type DS: PN16
- Pressure stage Kamstrup stainless steel pockets: PN25/PN40 - depending on type

At medium temperatures above 90°C we recommend the use of flanged flow sensors as well as wall mounting of SVM S6.

2. Mounting of temperature sensors

The temperature sensors used to measure flow and return temperatures respectively are a matched sensor pair that must never be separated.

SVM S6 is available with temperature sensors mounted from the factory. Alternatively the temperature sensors are supplied separately.

According to EN 1434 or OIML R75 the cable length must not be changed. If necessary, sensors must always be replaced in pairs.

The sensor marked with a red sign is to be mounted in the flow pipe. The other sensor marked with a blue sign is to be mounted in the return pipe (see paragraph 4 page 8).

2.1 Pocket sensor pair

Preferably, sensor pockets must be mounted in tee-pieces or in 45° lateral Y-pieces. The tip of the sensor pocket must point in the flow direction and should be placed in the middle of the water flow.

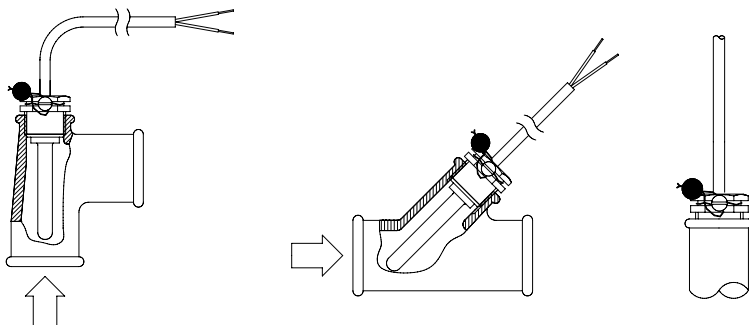

The temperature sensors should reach the bottom of the pockets. If a short response time is required, "non-hardening" heat conducting paste can be used.

Push the plastic sleeve on the sensor cable into the sensor pocket and secure the cable by means of the enclosed M4 sealing screw. Fasten the screw with your fingers only. Seal the pockets using seal and locking wire.

2.2 Short direct temperature sensor pair

The short direct sensors can be mounted in special ball valves or in special tee-pipes, both with threads up to R1 and built-in M10 union for the short direct sensor. For mounting in existing heating installations with standard angle tees Kamstrup can, furthermore, supply R $\frac{3}{2}$ and R $\frac{3}{4}$ brass nipples fitting the short direct sensors. The short direct sensor can also be fitted directly into all Kamstrup's ULTRAFLOW® variants with G $\frac{3}{4}$ and G1 thread on the meter case. Fasten the sensors' brass unions lightly (approx. 4 Nm) using a 12 mm face wrench and seal the sensors with seal and locking wire.

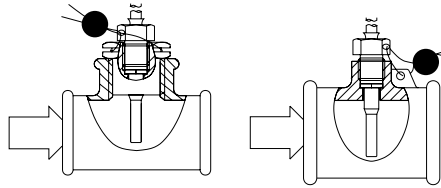

3. Mounting of flow sensor

Prior to installation of the flow sensor, the system should be flushed and protection plugs/plastic diaphragms removed from the flow sensor. Correct flow sensor position (flow or return) appears from the front label of SVM S6. The flow direction is indicated by an arrow on the side of the flow sensor.

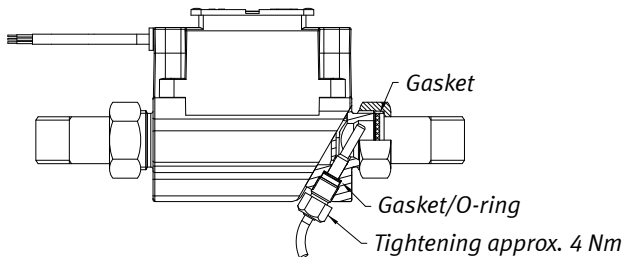

Glands and gaskets are mounted as shown in the above drawing.

ULTRAFLOW® requires neither straight inlet nor straight outlet to meet the Measuring Instruments Directive (MID) 2004/22/EF, OIML R75:2002 and EN 1434:2007. A straight inlet section will only be necessary in case of heavy flow disturbances before the sensor. We recommend to follow the guidelines of CEN CR 13582.

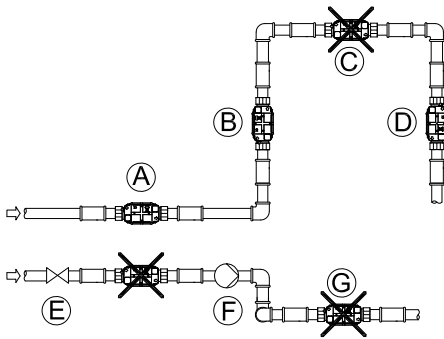

- A** Recommended flow sensor position.
- B** Recommended flow sensor position.
- C** Unacceptable position due to risk of air build-up.
- D** Acceptable in closed systems. Unacceptable position in open systems due to risk of air build-up in the system.
- E** A flow sensor ought not to be placed immediately after a valve, with the exception of block valves (ball valve type) which must be fully open when not used for blocking.
- F** A flow sensor must never be placed on the inlet side of a pump.
- G** A flow sensor ought not to be placed after a double bend in two levels.

In order to prevent cavitation the back pressure at ULTRAFLOW® must be minimum 1.5 bar at qp and minimum 2.5 bar at qs. This applies to temperatures up to approx. 80°C.

ULTRAFLOW® must not be exposed to lower pressure than the ambient pressure (vacuum).

3.1 Mounting ULTRAFLOW® ≤ DN125

The electronics/plastics case must be mounted separately if the meter is horizontally mounted

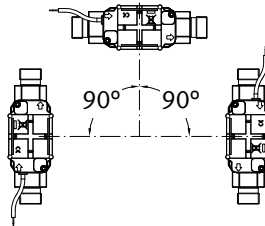

ULTRAFLOW® can be mounted vertically, horizontally or at an angle.

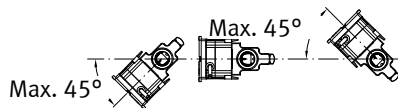

ULTRAFLOW® may be turned up to ±45° in relation to the pipe axis.

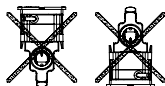

ULTRAFLOW® must not be mounted with the plastic case pointing upwards or downwards.

3.2 Mounting ULTRAFLOW® 54 ≥ DN150

See installation instructions No. 5512-887.

3.3 Installation examples

Threaded meter with SVM S6/Pulse Transmitter mounted on ULTRAFLOW®.

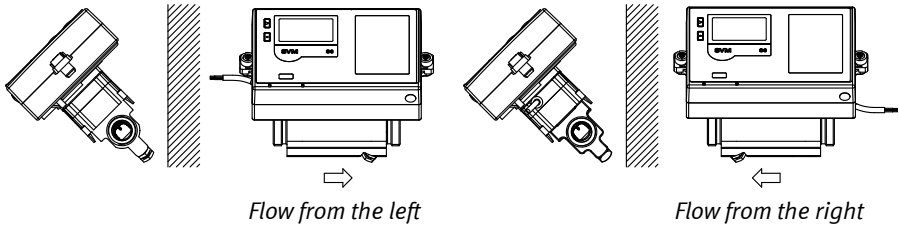

Flanged meter with SVM S6/Pulse Transmitter mounted on ULTRAFLOW®.

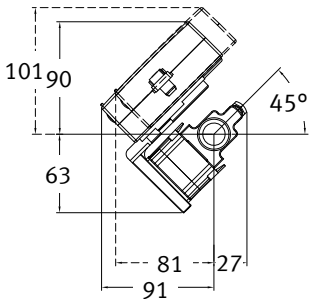
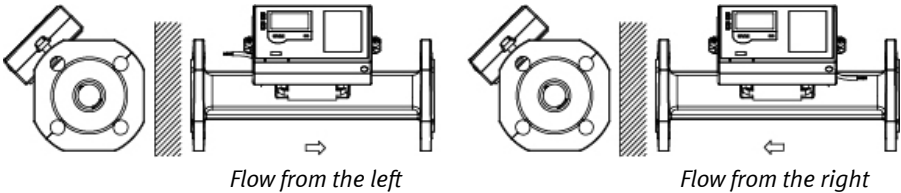

SVM S6 can be mounted in two positions by means of an angle fitting.

Angle fitting type 302-6-252 is ordered separately.

3.3.1 Humidity and condensation

If ULTRAFLOW® is installed in a moist environment, it must be turned 45° compared to the pipe axis as shown in the drawing below.

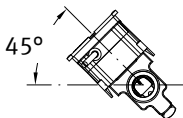

If there is risk of condensation, e.g. in cooling systems, a condensation protected ULTRAFLOW® must be used.

4. Electrical connection of SVM S6 and ULTRAFLOW®

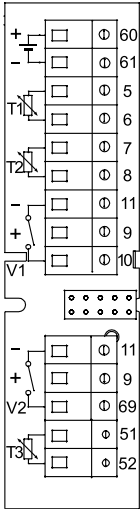

The polarity of temperature sensors T1, T2 and T3 is unimportant. For flow sensors V1 and V2 the below-mentioned colours are used when connecting ULTRAFLOW® and electronic pick-up units.

Flow sensors with reed switch output are connected to terminals 11–10 and 11–69 respectively.

	V1	V2	
-	11	11	Blue
+	9	9	Red
SIG	10	69	Yellow

	Terminal no.	Standard heat and cooling measurement	Heat measurement and leak monitoring	Energy measurement in open systems
T1	5–6	Sensor in flow (red)	Sensor in flow (red)	Sensor in flow (red)
T2	7-8	Sensor in return (blue)	Sensor in return (blue)	Sensor in return (blue)
V1	11–9–10	Flow sensor in flow or return	Flow sensor in flow	Flow sensor in flow
V2	11–9-69	-	Flow sensor in return	Flow sensor in return
T3	51-52	-	Tank/exchanger temp., if any	Reference sensor (grey)

4.1 Connection example

Examples of connection of ULTRAFLOW® and SVM S6 (battery supplied).

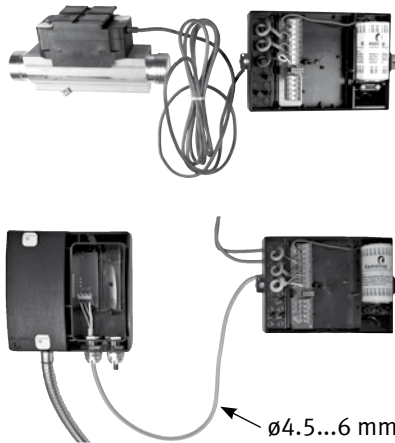

4.2 Heat meters with two flow sensors

SVM S6 can be used in various applications with two flow sensors, including leak monitoring and open systems. When two ULTRAFLOW® are direct connected to the calculator SVM S6 the district heating pipes must be connected to earth as a main rule. If both pipes are installed in a heat exchanger close to the flow sensors, however, the heat exchanger will provide the necessary earth connection.

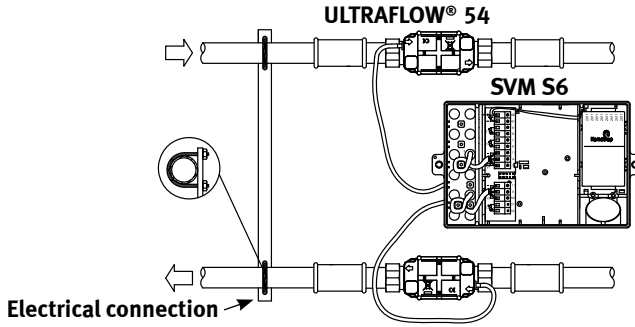

- Forward and return pipes are closely electrically coupled
- No welded joints occur

In installations where earth connection is not possible or welding in the pipe system can occur, the cable from one ULTRAFLOW® must go through a Pulse Transmitter, which must be galvanically separated, before the cable is connected in SVM S6.

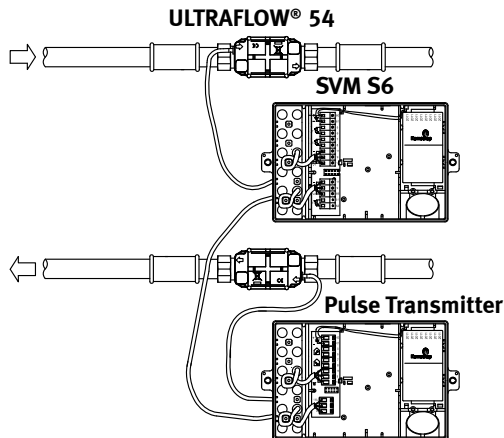

- Forward and return pipes are not necessary closely coupled
- Electric welding*) can occur

*) Electric welding must always be carried out with the earth pole closest to the welding point. Damage to meters due to welding is **not** comprised by our factory guarantee.

5. Mounting of calculator

The calculator SVM S6 can be mounted in three different ways:

5.1 Compact mounting

The calculator is mounted direct on the flow sensor, e.g via an angle fitting. Having been mounted the calculator is sealed with seal and thread.

In case of strong condensation (e.g. in cooling applications) we recommend wall mounting of the calculator. See point. 3.1 "Mounting ULTRAFLOW® ≤ DN125" page 6.

5.2 Separate/wall mounting

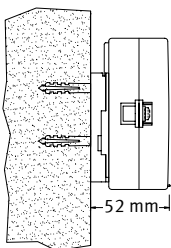

Kamstrup recommend wall mounting of the calculator in moist environments. Wall mounting also prolongs the battery lifetime.

The wall fitting makes it possible to mount SVM S6 direct on an even wall.

Use the fitting as a template to mark and drill two 6 mm holes in the wall.

5.3 Panel mounting

By means of Kamstrup's panel mounting kit, No. 66-99-104 (192 x 144 mm) SVM S6 can be mounted direct in panels or control panels.

6. Voltage supply of calculator/Pulse Transmitter

SVM S6 can be powered by a built-in lithium battery, an integral 24 VAC or 230 VAC mains module.

The two cables from battery or mains module are mounted in the calculator's terminals Nos. 60 and 61.

⚠ The polarity must be correct: red wire to terminal no. 60 (+) and black wire to terminal no. 61 (-).

6.1 Battery supply

SVM S6 is connected to a D-cell lithium battery. The battery is marked with installation year, e.g. 2011, as well as production date.

Optimal battery lifetime is obtained by keeping the battery temperature below 30°C, e.g. by wall mounting.

The voltage of a lithium battery is almost constant throughout the lifetime of the battery (approx. 3.65V). Thus, it is not possible to determine the remaining capacity of the battery by measuring the voltage.

The battery must not be charged and must not be short-circuited. Used batteries must be handed in for approved destruction, e.g. at Kamstrup AB.

6.2 Mains modules

The modules are protection class II. They are connected by means of a two-wire cable (without earth connection) through the calculator's cable bush in the bottom right corner of the connecting base. Use connecting cable with an outer diameter of 5-10 mm and ensure correct dismantling as well as correct mounting of cable relief.

Max. permitted fuse: 6 A

National regulations for electric installations must be observed.

6.2.1 High-power supply modules

These modules are galvanically separated from the mains supply. The modules include a "Switch Mode Power Supply" (SMPS), which fulfils double-isolation requirements when the calculator top is mounted. The modules are available in two variants, 24 VAC or 230 VAC.

6.2.2 Isolated linear supply modules

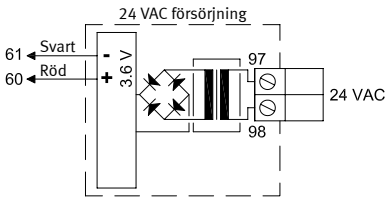

24 VAC

For instance a 230/24 V transformer, type 66-99-403, can be used.

Note! SVM S6 cannot be powered by 24 VDC.

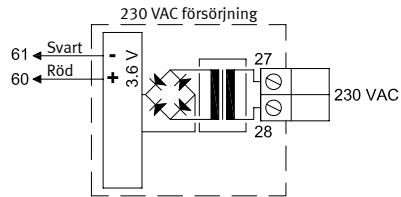

230 VAC

This module is used in connection with direct mains connection.

Note! External supply must be connected to the supply module.

7. Testing of function

Carry out an operational control when the energy meter has been fully mounted. Open thermoregulators and cocks to establish water flow through the heating system. Activate the top key of SVM S6 and check that the displayed values for temperature and water flow are credible values.

8. Information codes “INFO”

SVM S6 constantly monitors a number of important functions. In case of a serious error in measuring system or installation “INFO” is displayed and an info-code can be read by activating the top front key until “INFO” is displayed. The info code is only displayed when the error is present.

Info code	Description	Response time
0	No irregularities	-
1	Supply voltage has been interrupted	-
8	Temperature sensor T1 outside measuring range	1...10 min.
4	Temperature sensor T2 outside measuring range	1...10 min.
32	Temperature sensor T3 outside measuring range	1...10 min.
64	Leak in cold water system	24 hours
256	Leak in heating system	24 hours
512	Burst in heating system	120 s.
ULTRAFLOW® 54 info (must be activated CCC=4XX)		
16	Flow sensor V1, communication error	After reset and 24 hours (at 00:00)
1024	Flow sensor V2, communication error	After reset and 24 hours (at 00:00)
2048	Flow sensor V1, wrong pulse figure	After reset and 24 hours (at 00:00)
128	Flow sensor V2, wrong pulse figure	After reset and 24 hours (at 00:00)
4096	Flow sensor V1, signal too weak (air)	After reset and 24 hours (at 00:00)
8192	Flow sensor V2, signal too weak (air)	After reset and 24 hours (at 00:00)
16384	Flow sensor V1, wrong flow direction	After reset and 24 hours (at 00:00)
32768	Flow sensor V2, wrong flow direction	After reset and 24 hours (at 00:00)

If a number of info codes appear at a time, the sum of the info codes is displayed. If e.g. both temperature sensors are outside measuring range, info code 12 is displayed.

9. Plug-in modules

SVM S6 can be extended by a wide range of extra functions by means of plug-in modules. The individual modules are briefly described below.

9.1 Base modules

9.1.1 Data/pulse input, type 67-00-10

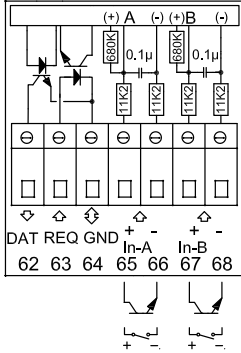

The data terminals are used for connection of e.g. a PC. The signal is passive and galvanically separated by means of optocouplers. Conversion into RS232 level requires connection of data cable 66-99-106 (D-Sub 9F) or 66-99-098 (USB) using the following connections:

62	Brown	(DAT)
63	White	(REQ)
64	Green	(GND)

The pulse inputs can be used for connection of electricity and water meters.

Please pay attention to maximum pulse frequency as well as correct pulse coding (l/imp. and Wh/imp.), which is selected by means of the FF and GG configurations respectively.

65 - 66	Input A
67 - 68	Input B

9.1.2 M-Bus, type 67-00-20/27/28

M-Bus can be mounted in star, ring or bus topology. Up to 250 meters can be connected depending on the M-Bus Master's power supply and the total cable resistance.

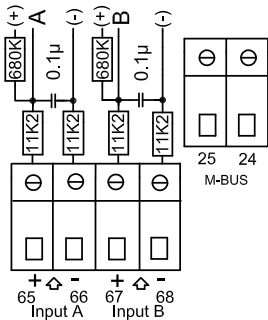

Cable resistance < 29 Ohm

Cable capacity < 180 nF

The M-Bus network is connected on terminals 24 and 25. The polarity is unimportant.

M-Bus comes with pulse input.

9.1.3 Radio/pulse inputs, type 67-00-25/26

The radio module is used for wireless communication via licence-free radio frequency and can be supplied with internal antenna or with connection for external antenna.

For further information on radio we refer to the document: *Technical description for radio (5512-012)*.

The pulse inputs of this module are identical with the previously described pulse inputs.

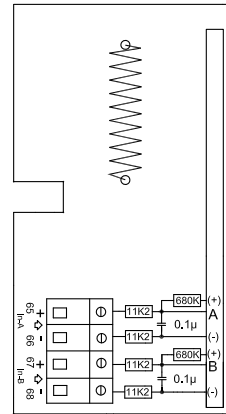

9.1.4 Prog. data logger + RTC + 4...20 mA input + pulse input, type 67-00-22

The module has connection possibility for two pressure transmitters on terminals 57, 58 and 59 and can be adjusted for current reading or pressure range 6, 10 or 16 bar.

The module is prepared for remote reading, data from meter/module being transferred to system software (AMR system) via an externally connected GSM/GPRS modem attached on terminals 62, 63 and 64.

Furthermore, the module has two extra pulse inputs, VA and VB.

The module must be powered by 24 VAC.

9.1.5 Analog outputs, type 67-00-23

See installation instructions 5512-369 (DK-GB-DE).

9.1.6 Lon Works, type 67-00-24

See installation instructions 5512-1101 (DK) or 5512-1105 (GB).

9.1.7 Wireless M-Bus, type 67-00-30, 602-00-035

The radio module has been designed to form part of the hand-held Wireless M-Bus Reader system of Kamstrup at licence-free radio frequency (868 MHz).

The module fulfils the C-mode specifications of prEN13757-4 and can thus form part of other systems using Wireless M-Bus with C-mode communication.

The module comes with internal antenna and connection for external antenna as well as two pulse inputs. These inputs are identical with the previously described pulse inputs.

The Wireless M-Bus radio transmitter is switched off on dispatch from the factory. It turns on automatically when one litre of water has run through the meter. The radio transmitter can also be switched on manually by keeping both of the meter's front keys activated for approx. 5 s. (until CALL is displayed).

9.1.8 ZigBee + pulse input, type 67-00-60

The ZigBee module is used for wireless communication and can form part of a remote reading system, in which several units can communicate with each other.

The pulse inputs of this module are identical with the previously described pulse inputs.

The ZigBee module requires mains supply.

9.1.9 Metasys N2 + pulse input, type 67-00-62

The N2 module is used for data communication between meters and N2 Master in a Johnson Controls System.

The RS485 port is galvanically separated from the meter.

The pulse inputs of this module are identical with the previously described pulse inputs.

The N2 module requires mains supply.

9.1.10 SIOX module (Auto detect Baud rate), type 602-00-64

SIOX is used for wired data reading of small and medium-sized groups of heat meters, the data readings being presented by the main system, e.g. MCom, Fix or Telefrang. Further details on these systems can be ordered from the supplier in question. Furthermore, a configuration tool is available from Telefrang.

The two-wire serial SIOX bus connection is optoisolated from the meter and is connected without regard to polarity (i.e. the polarity is unimportant). The module is powered by the SIOX bus. The communication speed is between 300 and 19200 baud. The module automatically uses the highest possible communication speed. The module converts data from KMP protocol to SIOX protocol.

9.1.11 GSM/GPRS module (GSM6H), type 602-00-80

The GSM/GPRS module functions as transparent communication path between reading software and SVM S6 and is used for data reading. The module includes an external dual-band GSM antenna which must be used. The module itself includes a number of light emitting diodes indicating the signal quality of the module. This is very useful during installation. The GSM/GPRS module (GSM6H) (602-00-80) must be used together with high-power mains supply (230 VAC: 602-00-00-3 or 24 VAC: 602-00-00-4).

9.1.12 Ethernet/IP module (IP201), type 602-00-82

The IP module functions as transparent communication path between reading software and SVM S6 and is used for data reading. The module supports both dynamic and static addressing. This is specified in the order or selected during subsequent configuration. The module has no built-in security and must, therefore, always be used in connection with a firewall or NAT. The high-power RadioRouter module (602-00-84) must be used together with high-power mains supply (230 VAC: 602-00-00-3 or 24 VAC: 602-00-00-4).

9.1.13 High-Power RadioRouter + 2 pulse inputs (VA, VB), type 602-00-84

The high-power RadioRouter module has built-in router functionality and is thus optimized to form part of a Kamstrup radio network, the read data being automatically transferred to system software via the network unit "RF Concentrator". Furthermore, the module can be read by Kamstrup's hand-held reading systems, e.g. USB Meter Reader and hand-held terminal Multiterm Pro. The RadioRouter module is available for operation in both licence-free and licence demanding frequencies permitting a transmitting strength of up to 500 mW . The module is per default fitted with internal antenna, connection for external antenna, and two extra pulse inputs. The high-power RadioRouter module (602-00-84) must be used together with high-power mains supply (230 VAC: 602-00-00-3 and 24 VAC: 602-00-00-4).

9.2 Top modules

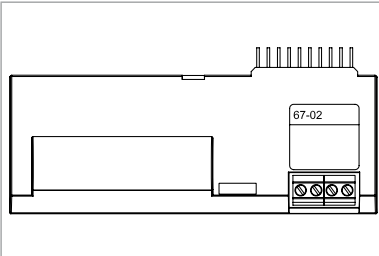
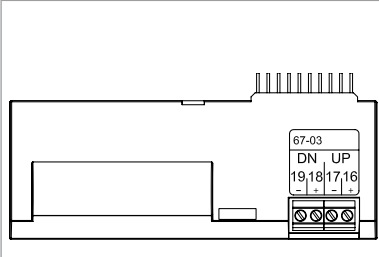
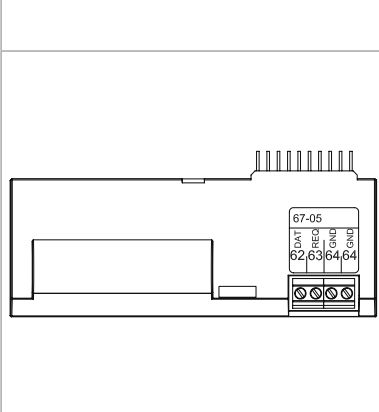
	<p>Type 67-02: Calculation of Δenergy and hourly data logger</p> <p>This top module calculates the difference between forward temperature (energy) and return temperature (energy), whereby an expression of tapped energy in open systems is obtained. Differential energy: $dE=E4-E5$. The module also includes an hourly data logger</p> <p>Connection terminals of this module are not used.</p>
	<p>Type 67-03: PQ-limiter + hourly data logger</p> <p>The module has two pulse outputs which are used for UP/DOWN control of a low-speed three-point motor-operated valve with an external solid state relay type S75-90-006 and a 230/24V transformer, type 66-99-403. The required power and flow limits are set in the calculator SVM S6 using the PC-program METERTOOL. See further details in document 5512-497. The module also includes an hourly data logger</p>
	<p>Type 67-05: Data output + hourly data logger</p> <p>Functions with the KMP protocol. The data output can be used for e.g. connection of external communication units or other "hardwired" data communication which it is not expedient to carry out via the optical eye. 62: DATA (Brown)–63:REQ (White)–64: GND Green). Use data cable type 66-99-106 with 9-pole D-sub or type 66-99-098 with USB connector. The module also includes an hourly data logger. Current and accumulated data can be read. Hourly/daily/monthly/yearly data loggers cannot be read through the data port of top module 67-05.</p>

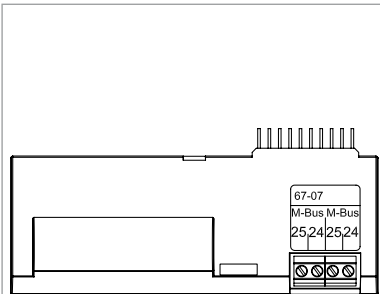

Type 67-07: M-Bus

M-Bus can be mounted in star, ring or bus topology. Depending on M-Bus-Master and cable length/ cross section, up to 250 meters with primary addressing can be connected, and even more using secondary addressing.

Cable resistance in network: < 29 Ohm
 Cable capacity of network: < 180 nF

The connection polarity of terminals 24-25 is unimportant.

Usually the primary address consists of the last digits of the customer number (000-250). However, it can be changed by means of the PC program METERTOOL.

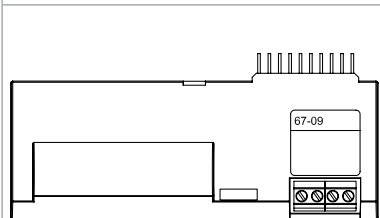

Type 67-09: Calculation of Δvolume and hourly data logger

This top module calculates the difference between forward and return volume, whereby an expression of tapped volume in open systems is obtained. Differential volume $dV=V1-V2$.

The module also includes an hourly data logger
The connection terminals of this module are not used.

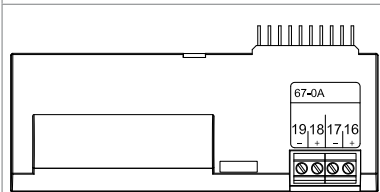

Type 67-0A: 2 pulse outputs for CE and CV + hourly data logger + scheduler

The top module has the same functions as top module 602-0C and can simulate cold water temperature according to a programmable scheduler, in which T2, T3 or T4 can be programmed with up to 12 individual dates/temperatures per year.

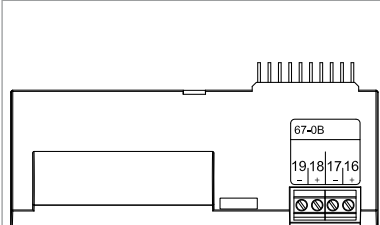

Type 67-0B: 2 pulse outputs for CE and CV + prog. data logger

The RTC and pulse output functions of this top module are identical with the functions described for top module 602-0C (see below). The top module is prepared for use in a Kamstrup radio network together with high-power RadioRouter base module 6020084. Read data are transferred to system software via the RF Concentrator (multipoint).

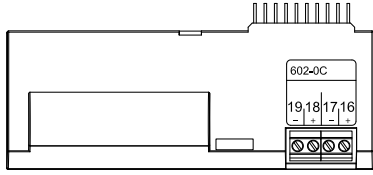

Typ 602-0C: 2 pulse outputs for CE and CV

This top module has two configurable pulse outputs for volume and energy pulses for heat meters, cooling meters and combined heat/cooling meters. The pulse resolution follows the display (determined by the CCC-code). E.g. CCC=119 (qp 1.5): 1 pulse/kWh and 1 pulse/0.01m³.

The pulse outputs are optoisolated and withstand 30 VDC and 10 mA. Connect energy (CE) on 16-17 and volume (CV) on 18-19. Other combinations can be selected by means of the PC program METERTOOL, which is also used for selecting pulse duration of 32 or 100 ms.

10. Electrical connection of SVM S6, ULTRAFLOW® and Pulse Transmitter

Connection of SVM S6 and ULTRAFLOW®

ULTRAFLOW®	→	SVM S6
Blue (GND)/11A	→	11
Red (supply)/9A	→	9
Yellow (signal)/10A	→	10

Connection via Pulse Transmitter

ULTRAFLOW®	→	Pulse Transmitter		→	SVM S6
		In	Out		
Blue (GND)/11A	→	11	11A	→	11
Red (supply)/9A	→	9	9A	→	9
Yellow (signal)/10A	→	10	10A	→	10

Using long control cables careful consideration is required in connection with installation.

There must be a distance of **minimum 25 cm** between control cables and other cables with a view to EMC.

Electrical connection

Connection of Pulse Transmitter.

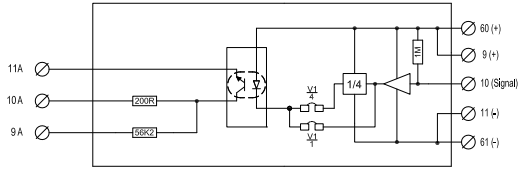

Block diagram

Pulse Transmitter output.

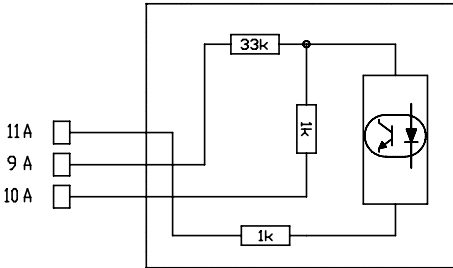

11A Earth
 9A Supply (3...10 VDC)
 10A Signal
 I_{max} 0.2 mA

If ULTRAFLOW® 54 is used as flow sensor/pulse transmitter for other calculator makes, the connection must be made via a Pulse Transmitter or Pulse Divider.

11. Setup via front keys

Date, time and primary M-Bus address can be adjusted by means of the keys on the calculator's front.

- 1 Select the display reading you want to change
- 2 Lift off the calculator top
- 3 Wait until the meter has shut down (can take up to 2.5 min.) Do not press any keys.
- 4 While remounting the calculator top, keep the main key  activated until there are no more lines in the display.
- 5 The setup menu is now active.

Having activated the setup menu, the reading you want to change is displayed with the rightmost digit flashing:



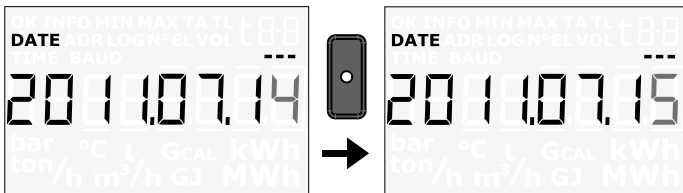

The value of the flashing digit can be changed by pressing the sub-key . The digit is increased by one each time the key is pressed, and passing 9 you start from 0:

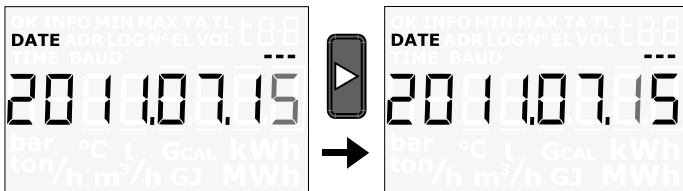

Pressing the main key  the next digit to the left starts flashing:



The active digit flashes and can be changed by pressing the sub-key . You go to the first digit from the right by means of the main key .

When the value has been changed and the settings are ready you quit by pressing the main key  continuously for approx. 10 seconds.

It should be checked whether the value is valid for the reading in question. If so, the value is saved and an "OK" symbol is displayed. If not, the old value is maintained, no "OK" symbol appears, and the display reverts to legal reading.

Consumed energy in kWh, MWh or GJ.

E | VOL | **0045321** | MWh

DATE LOG MAX **0023107**

Latest target date.
Energy count on latest target date followed by energy count on last year's target date. Followed by monthly count.

Consumed district heating water.

VOL | **0032456** | m³

DATE LOG MAX **0023195**

Latest target date.

Consumed district heating water.

VOL | **0031985** | m³

DATE LOG MAX **0023195**

Volume count on latest target date followed by volume count on last year's target date. Subsequently max. values for the latest 12 months and then pulse value and Qp for V1 are displayed. Latest target date.

Current heat flow rate

MAX | **146** | kW

DATE LOG MAX **20110317**

Value for max. power during the current year. Followed by max. values for the latest 12 months.

Current flow.

VOL | **316** | l/h

DATE LOG MAX **20120317**

Date of max. flow this year.

Value of max. flow this year. Followed by max. values for the latest 2 years.

Date of max. flow this month.

MIN LOG MAX **1474** | l/h

Value of max. flow this month. Followed by max. values the latest 12 years.

Current forward temperature.

t | **76.89** | °C

(?) Activate **B** to see the year's average forward temperature.

Current return temperature.

t | **34.21** | °C

(?) Activate **B** to see the year's average return temperature.

Current temperature difference.

t | **42.68** | K

Water volume consumed on pulse input A. Followed by consumed water volume on pulse input B.

VOL | **0015638** | m³

N | **75420145** | R

Serial number of the cold water meter connected to pulse input A. Followed by monthly value and pulse value of pulse input A.

