

Technical description

## SVM S6

---



Kamstrup AB  
Enhagsslingan 2  
SE-187 40 Täby  
TEL: +46 8 522 265 00  
FAX: +46 8 522 265 08  
info@kamstrup.se  
www.kamstrup.se



**List of contents**

**1 General description ..... 6**

**2 Technical Data ..... 7**

    2.1 Approved meter data .....7

    2.2 Electrical data.....8

    2.3 Mechanical data ..... 10

    2.4 Materials ..... 10

    2.5 Accuracy..... 10

**3 Type overview ..... 11**

    3.1 Type and programming overview ..... 11

    3.2 Type number combination ..... 12

    3.3 PROG, A-B-CCC-CCC ..... 14

    3.4 Display coding..... 21

    3.5 >EE< Configuration of MULTITARIFF ..... 23

    3.6 >FF< Input A (VA) - pulse divider, >GG< Input B (VB) - pulse divider..... 25

    3.7 Configuration of pulse outputs in the top module..... 26

    3.8 >MN< Configuration of leak limits..... 26

    3.9 >T< Configuration of encryption level..... 26

    3.10 Data for configuration ..... 27

**4 Dimensional sketches ..... 28**

**5 Installation ..... 29**

    5.1 Flow pipe and return pipe placing ..... 29

    5.2 EMC conditions..... 30

    5.3 Climatic conditions..... 30

    5.4 Electric installations ..... 30

**6 Calculator functions ..... 31**

    6.1 Energy calculation ..... 31

    6.2 Application types..... 32

    6.3 Calculator with two flow sensors ..... 37

    6.4 Combined heat/cooling metering..... 38

    6.5 Flow measurement, V1 and V2 ..... 39

    6.6 Power measurement, V1 ..... 40

    6.7 Min. and max. flow and power, V1 ..... 41

    6.8 Temperature measurement ..... 42

    6.9 Display functions..... 44

    6.10 Real Time Clock (RTC)..... 47

    6.11 Info codes ..... 48

    6.12 Tariff functions ..... 51

    6.13 Data loggers ..... 56

6.14	Leak surveillance .....	58
6.15	Reset functions .....	61
6.16	SMS Commands .....	61
6.17	Set-up via the front keys .....	63
6.18	Reset via the front keys .....	65
6.19	Preset the pulse value for V1 and V2 .....	66
<b>7</b>	<b>Flow sensor connection .....</b>	<b>67</b>
7.1	Volume inputs V1 and V2.....	67
7.2	Flow sensor with active 24 V pulse output ④ .....	69
7.3	Pulse inputs VA and VB.....	72
<b>8</b>	<b>Temperature sensors.....</b>	<b>74</b>
8.1	Sensor types.....	75
8.2	Cable influence and compensation .....	76
8.3	Pocket sensors .....	78
8.4	Pt500 short direct sensor set .....	79
<b>9</b>	<b>Voltage supply.....</b>	<b>80</b>
9.1	Integral D-cell lithium battery .....	80
9.2	Battery lifetimes.....	81
9.3	High Power supply module 230 VAC.....	82
9.4	High Power supply module 24 VAC.....	82
9.5	Supply module 230 VAC.....	83
9.6	Supply module 24 VAC.....	83
9.7	Exchanging the supply unit .....	85
9.8	Mains supply cables .....	85
9.9	Back-up of data during power down .....	86
<b>10</b>	<b>Plug-in modules.....</b>	<b>87</b>
10.1	Top modules.....	87
10.2	Base modules.....	93
10.3	Retrofitting modules .....	102
<b>11</b>	<b>Data communication .....</b>	<b>103</b>
11.1	SVM S6 data protocol .....	103
11.2	SVM S6 communication paths .....	105
11.3	Optical eye .....	105
<b>12</b>	<b>Calibration and verification .....</b>	<b>106</b>
12.1	High-resolution energy reading .....	106
12.2	High-resolution volume for test .....	107
12.3	Verification adapter .....	108
12.4	True energy calculation .....	109

- 13 METERTOOL and LogView for SVM S6 ..... 110**
  - 13.1 Introduction.....110
  - 13.2 METERTOOL SVM S6 .....111
  - 13.3 Verification .....115
  - 13.4 LogView .....118
- 14 Approvals ..... 120**
  - 14.1 CE marking .....120
  - 14.2 Measuring instrument directive.....120
- 15 Trouble-shooting ..... 122**
- 16 Disposal ..... 123**
- 17 Documents S6 ..... 124**

# 1 General description

SVM S6 is a thermal energy meter with many applications. In addition to being a precise and reliable heat meter for battery or mains operation, SVM S6 is also used for:

- Cooling measurement in water-based systems
- Bifunctional heat/cooling measurements in separate registers
- Leak surveillance of hot and cold-water installations
- Power and flow limiter with valve control
- Data logger
- Data communication
- Energy measurement in open systems

In designing the SVM S6 we have attached great importance to flexibility via programmable functions and plug-in modules (see chapter 10) in both the calculator top as well as in the base unit to ensure optimal use in a large number of applications. In addition, the construction ensures that already installed SVM S6 meters can be updated via the PC program METERTOOL.

This technical description is prepared to give utility managers, meter electricians, consulting engineers and distributors the possibility of utilizing all functions available in the SVM S6. Furthermore, the description is made for laboratories for the testing and verification process.

## 2 Technical Data

### 2.1 Approved meter data

Standard	EN 1434:2007, prEN 1434:2009 and OIML R75:2002	
EU directives	Measuring Instrument Directive, Low Voltage Directive, Electromagnetic Compatibility Directive	
Heat meter approval	DK-0200-MI004-020	The stated minimum temperatures apply to the type approval only. The meter has no cut-off for low temperature and thus measures as low temperatures as 0.01°C and 0.01 K.
Temperature range	θ: 2 °C...180 °C	
Differential range	Δθ: 3 K...170 K	
Cooling meter		
Temperature range	θ: 2 °C...50 °C	
Differential range	Δθ: 3 K...40 K	
Accuracy	$E_c \pm (0.5 + \Delta\theta_{\min}/\Delta\theta) \%$	
Temperature sensors	-Type S6-A	Pt100 – EN 60 751, 2-wire connection
	-Type S6-B and S6-D	Pt500 – EN 60 751, 4-wire connection
	-Type S6-C	Pt500 – EN 60 751, 2-wire connection
Compatible flow sensor types	<ul style="list-style-type: none"> <li>-ULTRAFLOW®</li> <li>-Electronic meters with an active 24 V pulse output</li> <li>-Mechanical meters with an electronic pick-up unit</li> <li>-Mechanical meters with a Reed switch</li> </ul>	
Flow sensor sizes	[kWh]	qp 0.6 m <sup>3</sup> /h...15 m <sup>3</sup> /h
	[MWh]	qp 0.6 m <sup>3</sup> /h...1500 m <sup>3</sup> /h
	[GJ]	qp 0.6 m <sup>3</sup> /h...3000 m <sup>3</sup> /h
EN 1434 designation	Environmental class A and C	
MID designation	Mechanical environment: Class M1	
	Electromagnetic environment: Class E1 and E2	
	5...55 °C, non condensing, closed location (indoor installation)	

## 2.2 Electrical data

### Calculator data

Typical accuracy	Calculator: $E_c \pm (0.15 + 2/\Delta\Theta) \%$ Sensor set: $E_T \pm (0.4 + 4/\Delta\Theta) \%$
Display	LCD – 7 (8) digits with a digit height of 7.6 mm
Resolution	9999.999 – 99999.99 – 999999.9 – 9999999
Energy units	MWh – kWh – GJ – Gcal
Data logger (EEPROM)	Standard: 1392 hours, 460 days, 36 months, 15 years, 50 info codes Option: Data loggers with programmable interval
Clock/calendar	Clock, calendar, compensation for leap years, target date, Real time clock with battery back-up
Data communication	KMP protocol with CRC16 used for optical communication and for top and base modules

Power in temperature sensors < 10  $\mu$ W RMS

**Supply voltage** 3.6 VDC  $\pm$  0.1 VDC

**Battery** 3.65 VDC, D-cell lithium

Stand-by current < 15  $\mu$ A excluding flow sensor

Replacement interval

- Mounted on the wall 12+1 years @  $t_{BAT} < 30^\circ\text{C}$

- Mounted on the flow sensor 10 years @  $t_{BAT} < 40^\circ\text{C}$

The replacement interval is reduced when using data modules, frequent data communication and high ambient temperature. See chapter 9.2.

**Mains supply** 230 VAC  $\pm$ 15/-30%, 50/60 Hz  
24 VAC  $\pm$ 50%, 50/60 Hz

Insulation voltage 4 kV

Power supply < 1W

Back-up supply Integral super-cap eliminates operational disturbances due to short-term power cuts (Power supply modules type 602-0000-7 and type 602-0000-8 only)

EMC data Meets prEN 1434-4:2009 class C (MID class E2)

### Temperature measurement

		T1	T2	T3	T4
<b>S6-A</b> <b>2-W Pt100</b>	Measuring range	0.00...185.00 °C	0.00...185.00 °C	0.00...185.00 °C	N/A
	Preset range	0.01...180.00 °C	0.01...180.00 °C	0.01...180.00 °C	0.01...180.00 °C
<b>S6-B/D</b> <b>4-W Pt500</b>	Measuring range	0.00...185.00 °C	0.00...185.00 °C	N/A	N/A
	Preset range	0.01...180.00 °C	0.01...180.00 °C	N/A	0.01...180.00 °C
<b>S6-C</b> <b>2-W Pt500</b>	Measuring range	0.00...185.00 °C	0.00...185.00 °C	0.00...185.00 °C	N/A
	Preset range	0.01...180.00 °C	0.01...180.00 °C	0.01...180.00 °C	0.01...180.00 °C

Max. cable lengths	Pt100, 2-wire	Pt500, 2-wire	Pt500, 4-wire
Max. $\varnothing$ 6mm cable	2 x 0.22 mm <sup>2</sup> : 2.5 m	2 x 0.22 mm <sup>2</sup> : 10 m	4 x 0.25 mm <sup>2</sup> : 100 m
	2 x 0.50 mm <sup>2</sup> : 5 m	2 x 0.50 mm <sup>2</sup> : 20 m	-
	2 x 1.00 mm <sup>2</sup> : 10 m		

<b>Flow measuring V1 and V2</b>	ULTRAFLOW® V1: 9-10-11 and V2: 9-69-11	Reed switches V1: 10-11 and V2: 69-11	24 V active pulses V1: 10B-11B and V2: 69B-79B
EN 1434 pulse class	IC	IB	(IA)
Pulse input	680 kΩ pull-up for 3.6 V	680 kΩ pull-up for 3.6 V	12 mA at 24 V
Pulse ON	< 0.4 V in > 0.5 msec.	< 0.4 V in > 100 msec.	< 4 V in > 3 msec.
Pulse OFF	> 2.5 V in > 10 msec.	> 2.5 V in > 100 msec.	> 12 V in > 10 msec.
Pulse frequency	< 128 Hz	< 1 Hz	< 128 Hz
Integration frequency	< 1 Hz	< 1 Hz	< 1 Hz
Electrical isolation	No	No	2 kV
Max. cable length	10 m	25 m	100 m

**Pulse inputs without bounce damping:**

<b>Pulse inputs VA and VB</b>	Water meter connection VA: 65-66 and VB: 67-68	Electricity meter connection FF(VA) and GG(VB) = 71...90
Pulse input	680 kΩ pull-up for 3.6 V	680 kΩ pull-up for 3.6 V
Pulse ON	< 0.4 V in > 30 msec.	< 0.4 V in > 30 msec.
Pulse OFF	> 2.5 V in > 100 msec.	> 2.5 V in > 100 msec.
Pulse frequency	< 1 Hz	< 3 Hz
Electrical isolation	No	No
Max. cable length	25 m	25 m
Requirements to external contact	Leakage current at function open < 1 μA	

**Pulse inputs with bounce damping:**

<b>Pulse inputs VA and VB</b>	Water meter connection VA: 65-66 and VB: 67-68
Pulse input	680 kΩ pull-up for 3.6 V
Pulse ON	< 0.4 V i > 200 ms.
Pulse OFF	> 2.5 V i > 500 ms.
Pulse frequency	< 1 Hz
Electrical isolation	None
Max. Cable length	25 m
Requirements to external contact	Leakage current at function open < 1 μA

**Pulse outputs CE and CV**

- via top module	67-0B	602-0C
Type	Opto FET	Open collector (OB)
External voltage	5...48 VDC/AC	5...30 VDC
Current	1...50 mA	1...10 mA
Residual voltage	$R_{ON} \leq 40 \Omega$	$U_{CE} \approx 1 \text{ V at } 10 \text{ mA}$
Electrical isolation	2 kV	2 kV
Max. cable length	25 m	25 m
Pulse length	Optional 32 msec. or 100 msec.	

### 2.3 Mechanical data

Environmental class	Meets EN 1434 class A and C
Ambient temperature	5...55 °C non condensing, closed location (indoor installation)
Protection class	IP54
Storage temperature	-20...60 °C (drained meter)
Weight	0.4 kg excluding sensors and flow sensor
Connection cables	ø3.5...6 mm
Supply cable	ø5...10 mm

### 2.4 Materials

Top cover	PC
Base unit	ABS with TPE packings (thermoplastic elastomer)
Print box	ABS
Wall brackets	PC + 30% glass
DIN rail bracket	PC + 20% glass

### 2.5 Accuracy

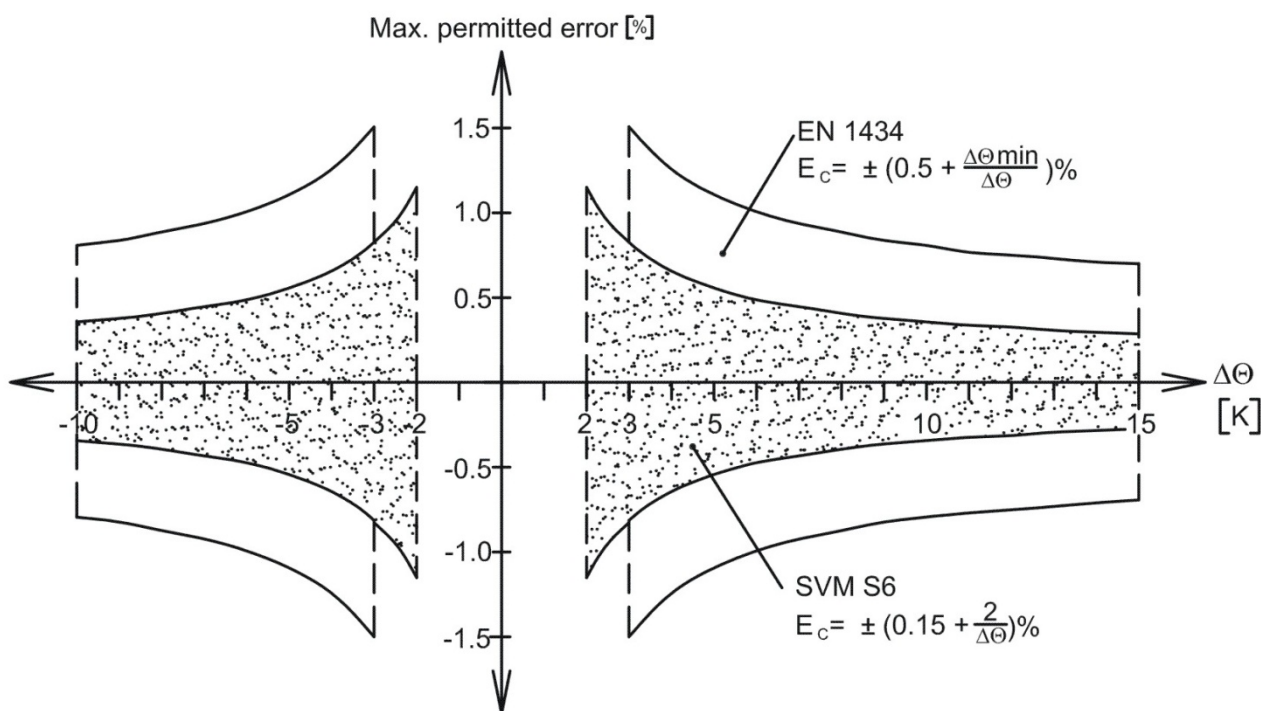

Figure 1. SVM S6 typical accuracy compared with EN 1434.

### 3 Type overview

SVM S6 can be ordered in a countless number of combinations as required by the customer. First the required hardware is selected in the type overview. Then “Prog”, “Config” and “Data” are selected to suit the application in question.

The meter is delivered completely configured and ready for use from the factory but it can also be retrofitted/reconfigured after installation.

Please note that the items marked “Totalprog” can only be changed when the verification seal is broken. This requires that the change must be made at an accredited meter laboratory.

New functions and modules for SVM S6 are constantly being developed. Please contact Kamstrup AB, if the described variants do not meet your requirements.

#### 3.1 Type and programming overview



##### Type number (Total prog.)

**S6-X-X-XX-X-XX-X-XXX**

Selection of Pt100/Pt500 calculator, modules, supply, sensor set, flow sensor and language on label

##### PROG (Total prog.)

**A-B-CCC-CCC**

- Flow pipe/Return pipe
- Energy unit
- Flow meter code

##### CONFIG (Partial prog.)

**DDD-EE-FF-GG-M-N-T**

- Display
- Tariff
- Pulse inputs
- Leak sensibility
- Pulse outputs
- AMR Encryption level

##### DATA (Partial prog.)

- Customer no.
- Target date
- Tariff limits
- Average peak time max./min.
- Date/time

### 3.2 Type number combination

	SVM S6	Type S6-	□	□	□□	□	□□	□	□	□□
<b>Sensor connection</b>										
Pt100	2-wire (T1-T2)		A							
Pt500	4-wire (T1-T2)		B							
Pt500	2-wire (T1-T2-T3)		C							
Pt500	4-wire (T1-T2) w/24 V pulse inputs		D							
<b>Top module</b>										
No module				0						
ΔEnergy calculation				2						
PQ or Δt-limiter				3						
Data output				5						
M-Bus				7						
ΔVolume				9						
2 pulse outputs for CE and CV + scheduler				A						
2 pulse outputs for CE and CV + prog. data logger				B						
2 Pulse outputs CE and CV				C						
<b>Base module</b>										
No module					00					
Data + pulse inputs					10					
M-Bus + pulse inputs <sup>1)</sup>					20					
Prog. data logger + RTC + 4...20 mA inputs + pulse inputs					22					
0/4...20 mA outputs					23					
LonWorks + pulse inputs					24					
Radio + pulse inputs (internal antenna) 434 or 444 MHz					25					
Radio + pulse inputs (external antenna connection) 434 or 444 MHz					26					
M-Bus module with alternative registers + pulse inputs					27					
M-Bus module with medium data package + pulse inputs					28					
Wireless M-Bus Mode C1 + pulse inputs					30					
Wireless M-Bus Mode C1 Alt. reg. + pulse inputs					35					
ZigBee 2.4 GHz int.ant. + pulse inputs					60					
Metasys N2 (RS485) + pulse inputs					62					
SIOX module (Auto detect Baud rate)					64					
BACnet MS/TP + pules inputs					66					
GSM/GPRS module (GSM6H)		Require			80					
3G GSM/GPRS module (GSM8H)		High-Power			81					
Ethernet/IP module (IP201)		supply			82					
High Power RadioRouter + pulse inputs		modules			84					
<b>Supply</b>										
No supply					0					
Battery, D-cell					2					
230 VAC high power isolated SMPS					3					
24 VAC high power isolated SMPS					4					
230 VAC isolated linear supply					7					
24 VAC isolated linear supply					8					
<b>Pt500 sensor set</b>										
No sensor set								00		
Pocket sensor set w/1.5 m cable								0A		
Pocket sensor set w/3.0 m cable								0B		
Pocket sensor set w/5 m cable								0C		
Pocket sensor set w/10 m cable								0D		
Short direct sensor set w/1.5 m cable								0F		
Short direct sensor set w/3.0 m cable								0G		
3 Pocket sensors in sets w/1.5 m cable								0L		
3 Short direct sensors in sets w/1.5 m cable								03		
<b>Flow sensor /pick-up unit</b>										
Supplied w/ 1 pcs. ULTRAFLOW® (Please specify type)									1	
Supplied w/2 pcs. (identical) ULTRAFLOW® (Please specify type)									2	
Prepared for 1 pcs. ULTRAFLOW® (Please specify type)									7	
Prepared for 2 pcs. (identical) ULTRAFLOW® (Please specify type)									8	
Prepared for meters w/electronic pulse output									K	
Prepared for meters w/Reed switch output (both V1 and V2)									L	
Prepared for meters w/24 V active pulses									M	
<b>Meter type</b>										
Heat meter, (MID module B+D)										2
Heat meter, (MID module B+D)										3
Cooling meter										5
Heat/Cooling meter										6
<b>Country code (language on label etc.)</b>										
										XX

**3.2.1 Comments to the Type number survey**

When placing orders please state ULTRAFLOW® type numbers separately.

<sup>1)</sup> See paragraph 10.2 for further details.

<sup>2)</sup> Requires two identical flow sensors.

**3.2.2 Accessories**

66-00-200-100	D-cell battery
602-0000-4000000	24 VAC high power isolated SMPS
602-0000-3000000	230 VAC high power isolated SMPS
602-0000-8000000	24 VAC isolated linear supply
602-0000-7000000	230 VAC isolated linear supply
66-99-624	Pulse transmitter/divider for S6-A and S6-C
66-99-614	4-wire connection PCB with pulse inputs for 24 V active pulses (for S6-D)
66-99-098	Data cable w/USB plug
66-99-099	Infrared optical reading head w/USB plug
66-99-144	Infrared optical reading head for Kamstrup/EVL w/USB plug
66-99-102	Infrared optical reading head w/D-sub 9F
66-99-106	Data cable RS 232, D-sub 9F
66-99-397/-398/-399	Verification unit (used with METERTOOL)
67-9xxxxxx2xx	External Communication Box
66-99-718	METERTOOL for S6
66-99-719	METERTOOL LogView for S6
59-15-145	DIN rail bracket

Please contact Kamstrup AB for questions concerning further accessories.

### 3.3 PROG, A-B-CCC-CCC

The legal parameters of the meter are determined by Prog, which can only be changed when the verification seal is broken. The change must then be made at an accredited meter laboratory.

**The A-code** indicates whether the flow sensor (V1) is installed in flow or return pipe. As water has a larger volume at higher temperatures, the calculator must be adjusted for the current installation type. Wrong programming or installation results in measuring errors. For further details on placing the flow and return pipe of the flow sensor in connection with heat and cooling meters, see paragraph 5.1.

**The B-code** indicates the measuring unit used for the energy register. GJ, kWh or MWh are used most frequently, whereas Gcal is only used in some countries outside the EEA.

**The CCC code** indicates the calculator’s adaptation to a concrete flow sensor type, i.e. the calculation speed and display resolution are optimised to the selected flow sensor type and at the same time the type approval regulations concerning min. resolution and max. register overflow are met. The CCC codes are divided into several tables to give a better survey.

CCC(V1) indicates the CCC code of the flow sensor and is connected to flow sensor input V1 on terminal 9-10-11 (or 10B-11B), which in most applications is the flow sensor used for calculating energy.

CCC(V2) indicates the CCC code of an extra flow sensor, if any, to be connected to terminal 9-69-11 (or 69B-79B). If V2 is not used, CCC(V2) = CCC(V1). In connection with leakage surveillance CCC(V2) = CCC(V1).

Prog. number	A	B	CCC (V1)	CCC (V2)
	□	□	□□□	□□□
<b>Flow sensor placing:</b>				
k-factor	- Inlet/Flow pipe (at T1)	3		
table	- Outlet/Return pipe (at T2)	4		
<b>Measuring unit, energy</b>				
- GJ		2		
- kWh		3		
- MWh		4		
- Gcal		5		
<b>Flow sensor coding (CCC-table)</b>			CCC	CCC

**3.3.1 CCC-table for SVM S6**

The CCC tables are divided into fast pulse codes (CCC=4XX, 2XX and 1XX) for electronic meters, e.g. ULTRAFLOW®, and slow codes for e.g. reed contacts (CCC=0XX).

**CCC= 4XX      Electronic meters with fast and bounce-free pulses as well as info codes for ULTRAFLOW® X4**

Max. pulse frequency: 128 Hz  
 Max. integration frequency: 1 Hz

**CCC= 1XX, 2XX      Electronic meters with fast and bounce-free pulses**

Max. pulse frequency: 128 Hz  
 Max. integration frequency: 1 Hz

**CCC= 0XX      Mechanical meters delivering slow pulses with bounce (flow sensor type "L")**

Max. pulse frequency: 1 Hz  
 Max. integration frequency: 1 Hz

Max. integration frequency is 1 Hz for all types. The CCC codes are arranged in a way that  $q_{s+20\%}$  (or  $Q_{max+20\%}$ ) does not exceed the 1 Hz in the integration frequency.

Example: CCC=107 (applies for a  $q_p$  1.5 m<sup>3</sup>/h meter) : 1 Hz in the integration frequency is obtained at  $q = 3.6$  m<sup>3</sup>/h.

EN 1434 makes demands on the resolution and registre size of the energy reading. SVM S6 meets these demands when connected to below flow sensor sizes:

[kWh]       $q_p$  0.6 m<sup>3</sup>/h...15 m<sup>3</sup>/h  
 [MWh]       $q_p$  0.6 m<sup>3</sup>/h...1500 m<sup>3</sup>/h  
 [GJ]       $q_p$  0.6 m<sup>3</sup>/h...3000 m<sup>3</sup>/h

**3.3.2 CCC codes for mechanical flow sensors with Reed switch**

CCC no.	Pre-counter	Flow factor	Number of decimals on the display										Qmax [m <sup>3</sup> /h]	Flow sensor
			kWh	MWh Gcal	GJ	m <sup>3</sup> [ton]	m <sup>3</sup> /h	l/h	kW	MW	l/pulses	Pulses/l		
010	1	921600	1	-	3	3	-	0	1	-	1	1	≤ 3,0	L
011	1	921600	-	3	2	2	2	-	0	-	10	0.1	1...30	L
012	1	921600	-	2	1	1	1	-	-	2	100	0.01	10...300	L
013	1	921600	-	1	0	0	0	-	-	1	1000	0.001	100...3000	L
020	4	230400	0	3	2	2	2	-	0	-	2.5	0.4	≤ 6	L
021	4	230400	-	2	1	1	1	-	-	2	25	0.04	3...60	L
022	4	230400	-	1	0	0	0	-	-	1	250	0.004	30...600	L

Current flow (l/h or m<sup>3</sup>/h) reading is calculated on the basis of the measured period between 2 volume pulses (see paragraph 6.5)

When one of above CCC codes has been selected both CCC (V1) and CCC (V2) must be selected from this table.

**Note:** Continuous maximum water flow and permanent  $\Delta\theta > 75$  K may cause overflow in the daily data logger at CCC=010-011-012-013-150-202-205. With these combinations we recommend you to use Prog. data logger type 67-0B or type 67-00-22.

3.3.3 CCC codes for ULTRAFLOW® II, type 65 54 XXX

CCC no.	Pre-counter	Flow factor	Number of decimals on the display								Pulses/l	qp [m³/h]	Type no.	Flow sensor
			kWh	MWh Gcal	GJ	m³ [ton]	l/h	m³/h	kW	MW				
116	3000	78642	0	3	2	2	0	-	1	-	300	0.6	65 54 A8X 65 54 AAX	1-2-7-8
119	1000	235926	0	3	2	2	0	-	1	-	100	1.5	65 54 A6X 65 54 A7X 65 54 A1X 65 54 A2X 65 54 A3X	1-2-7-8
136	500	471852	0	3	2	2	0	-	1	-	50.0	2.5	65 54 A4X 65 54 ADX	1-2-7-8
151	5000	471852	-	2	1	1	0	-	1	-	50.0	3.5	65 54 B1X 65 54 B7X	1-2-7-8
137	2500	943704	-	2	1	1	0	-	1	-	25.0	6.0 6.0 10 10	65 54 B2X 65 54 B5X 65 54 BGX 65 54 BHX	1-2-7-8
120	1000	2359260	-	2	1	1	0	-	1	-	10.0	15 25	65 54 B4X 65 54 B8X	1-2-7-8
158	5000	471852	-	1	0	0	-	2	0	-	5.0	40	65 54 B9X	1-2-7-8
170	2500	943704	-	1	0	0	-	2	-	3	2.5	60	65 54 BAX	1-2-7-8
147	1000	2359260	-	1	0	0	-	2	-	3	1.0	150	65 54 BBX	1-2-7-8
194	400	5898150	-	1	0	0	-	2	-	3	0.4	400	65 54 BCX	1-2-7-8
195	250	9437040	-	1	0	0	-	2	-	3	0.25	1000	65 54 BKX	1-2-7-8

Current flow reading (l/h or m³/h) is calculated on the basis of volume pulses/10 sec. (see paragraph 6.5)

3.3.4 CCC codes for ULTRAFLOW® type 65-R/S/T

CCC no.	Pre-counter	Flow-factor	Number of decimals on the display								Pulses/l	qp [m³/h]	Type no.	Flow part
			kWh	MWh Gcal	GJ	m³ [ton]	l/h	m³/h	kW	MW				
116	3000	78642	0	3	2	2	0	-	1	-	300	0.6	65-X-CAAA-XXX 65-X-CAAD-XXX	1-2-7-8-K
119	1000	235926	0	3	2	2	0	-	1	-	100	1.5	65-X-CDAC-XXX 65-X-CDAD-XXX 65-X-CDAE-XXX 65-X-CDAF-XXX 65-X-CDA-XXX	1-2-7-8-K-M
136	500	471852	0	3	2	2	0	-	1	-	50.0	3.0	65-X-CFAF-XXX 65-X-CFBA-XXX	1-2-7-8-K-M
151	5000	471852	-	2	1	1	0	-	1	-	50.0	3.5	65-X-CGAG-XXX 65-X-CGBB-XXX	1-2-7-8-K-M
137	2500	943704	-	2	1	1	0	-	1	-	25.0	6 6 10 10	65-X-CHAG-XXX 65-X-CHBB-XXX 65-X-C1AJ-XXX 65-X-C1BD-XXX	1-2-7-8-K-M
178	1500	1572840	-	2	1	1	0	-	1	-	15.0	10	65-X-CJAJ-XXX 65-X-CJBD-XXX	1-2-7-8-K-M
120	1000	2359260	-	2	1	1	0	-	1	-	10.0	15	65-X-CKBE-XXX	1-2-7-8-K-M
179	600	3932100	-	2	1	1	0	-	1	-	6.0	25	65-X-CLBG-XXX	1-2-7-8-K
120	1000	2359260	-	2	1	1	0	-	1	-	10.0	25	65-X-C2BG-XXX	1-2-7-8-K-M
158	5000	471852	-	1	0	0	-	2	0	-	5.0	40	65-X-CMBH-XXX	1-2-7-8-K-M
170	2500	943704	-	1	0	0	-	2	-	3	2.5	60	65-X-FABL-XXX 65-X-FACL-XXX	1-2-7-8-K-M
180	1500	1572840	-	1	0	0	-	2	-	3	1.5	100	65-X-FBCL-XXX	1-2-7-8-K
147	1000	2359260	-	1	0	0	-	2	-	3	1.0	150	65-X-FCBN-XXX 65-X-FCCN-XXX	1-2-7-8-K-M
181	600	3932100	-	1	0	0	-	2	-	3	0.6	250	65-X-FDCN-XXX	1-2-7-8-K
191	400	589815	-	1	0	0	-	1	-	2	0.4	400	65-X-FEBN-XXX 65-X-FEBR-XXX 65-X-FECN-XXX 65-X-FECP-XXX 65-X-FECP-XXX	1-2-7-8-K-M
192	250	943704	-	1	0	0	-	1	-	2	0.25	600 600 1000 1000	65-X-FFCP-XXX 65-X-FFCR-XXX 65-X-F1BR-XXX 65-X-F1CR-XXX	1-2-7-8-K-M
193	150	1572840	-	1	0	0	-	1	-	2	0.15	1000	65-X-FGBR-XXX	1-2-7-8-K

Current flow reading (l/h or m³/h) is calculated on the basis of volume pulses/10 sec. (see paragraph 6.5)

**3.3.5 CCC codes with high resolution for ULTRAFLOW® (for cooling meters etc.)**

CCC no.	Pre-counter	Flow factor	Number of decimals on the display								Pulses/l	qp [m³/h]	Type no.	Flow sensor
			kWh	MWh Gcal	GJ	m³ [ton]	l/h	m³/h	kW	MW				
184	300	78642	1	-	3	3	0	-	1	-	300	0.6		1-2-7-8
107	100	235926	1	-	3	3	0	-	1	-	100	1.5		1-2-7-8-M
136	500	471852	0	3	2	2	0	-	1	-	50.0	3.5		1-2-7-8-M
138	250	943704	0	3	2	2	0	-	1	-	25.0	6.0		1-2-7-8-M
183	150	1572840	0	3	2	2	0	-	1	-	15.0	10		1-2-7-8
185	100	2359260	0	3	2	2	0	-	1	-	10.0	15		1-2-7-8-M
186	500	471852	-	2	1	1	-	2	0	-	5.0	40		1-2-7-8-M
187	250	943704	-	2	1	1	-	2	-	3	2.5	60		1-2-7-8-M
188	150	1572840	-	2	1	1	-	2	-	3	1.5	100		1-2-7-8
189	100	2359260	-	2	1	1	-	2	-	3	1.0	150		1-2-7-8-M
191	400	589815	-	1	0	0	-	1	-	2	0.4	400		1-2-7-8-M
192	250	943704	-	1	0	0	-	1	-	2	0.25	600		1-2-7-8-M
193	150	1572840	-	1	0	0	-	1	-	2	0.15	1000		1-2-7-8

Current flow reading (l/h or m³/h) is calculated on the basis of volume pulses/10 sec. (see paragraph 6.5)

**3.3.6 CCC codes for other electronic meters with a passive output**

CCC no.	Pre-counter	Flow factor	Number of decimals on the display						l/pulse	Pulses/l	Qmax [m³/h]	Type	Flow sensor
			MWh Gcal	GJ	m³ [ton]	m³/h	kW	MW					
147	1000	2359260	1	0	0	2	-	3	1	-	18...75	SC-18	K-M
148	400	5898150	1	0	0	2	-	3	2.5	-	120...300	SC-120	K-M
149	100	2359260	1	0	0	1	-	2	10	-	450...1200	SC-450	K-M
150	20	11796300	1	0	0	1	-	2	50	-	1800...3000	SC-1800	K-M
175	7500	314568	1	0	0	2	-	3	-	7.5	15...30	DF-15	K-M
176	4500	524280	1	0	0	2	-	3	-	4.5	25...50	DF-25	K-M
177	2500	943704	1	0	0	2	-	3	-	2.5	40...80	DF-40	K-M

CCC no.	Pre-counter	Flow factor	Number of decimals on the display						l/pulse	Pulse/l	Qp range [m³/h]	Qs (m³/h)	Type	Flow sensor
			MWh Gcal	GJ	m³ [ton]	m³/h	MW							
201	100	235926	2	1	1	1	2	1	1	10...100	75	FUS380 DN50-65	K-M	
202	40	589815	2	1	1	1	2	2.5	0.4	40...200	240	FUS380 DN80-100	K-M	
203	400	589815	1	0	0	1	2	2.5	0.4	100...400	500	FUS380 DN125	K-M	
204	100	235926	1	0	0	0	1	10	0.1	150...1200	1600	FUS380 DN150-250	K-M	
205	20	1179630	1	0	0	0	1	50	0.02	500...3000	3600	FUS380 DN300-400	K-M	

Current flow reading (l/h or m³/h) is calculated on the basis of volume pulses/10 pcs. (see paragraph 6.5)

**3.3.7 CCC codes for other electronic meters with an active output**

Flow sensor with active 24 V pulse output, see paragraph 7.2

3.3.8 CCC codes for impeller wheel meters with an electronic pick-up unit

CCC no.	Pre-counter	Flow factor	Number of decimals on the display								Pulses/l	qp [m³/h]	Type	Flow sensor
			kWh	MWh Gcal	GJ	m³ [ton]	l/h	m³/h	kW	MW				
102	560	421296	0	3	2	2	0	-	1	-	56.0	1.5/2.5	GWF-MT3	K
103	300	786420	0	3	2	2	0	-	1	-	30.0	3.5	GWF-MT3	K
104	2520	936214	-	2	1	1	0	-	1	-	25.2	6	GWF-MT3	K
105	1230	1918098	-	2	1	1	0	-	1	-	12.3	10	GWF-MT3	K
106	1080	2184500	-	2	1	1	0	-	1	-	10.8	15	GWF-MT3	K
108	1403	168158	0	3	2	2	0	-	1	-	140.3	0.6	GWF	K
109	957	246527	0	3	2	2	0	-	1	-	95.7	1.0	GWF	K
110	646	365211	0	3	2	2	0	-	1	-	64.6	1.5	GWF	K
111	404	583975	0	3	2	2	0	-	1	-	40.4	1.5 (2.5)	HM (GWF)	K
112	502	469972	0	3	2	2	0	-	1	-	50.2	1.5 – 2.5*	GWF	K
113	2350	1003940	-	2	1	1	0	-	1	-	23.5	3.5 - 6*	GWF	K
114	712	331357	-	2	1	1	0	-	1	-	7.12	10 - 15*	GWF	K
115	757	311659	0	3	2	2	0	-	1	-	75.7	1.0*	GWF	K
116	3000	78642	0	3	2	2	0	-	1	-	300.0	0.6*	GWF	K
117	269	877048	0	3	2	2	0	-	1	-	26.9	1.5	Brunata	K
118	665	354776	0	3	2	2	0	-	1	-	66.5	1.5	Aquastar	K
119	1000	235926	0	3	2	2	0	-	1	-	100.0	0.6	HM	K
121	294	802469	0	3	2	2	0	-	1	-	29.4	1.5 – 2.5		K
122	1668	141442	0	3	2	2	0	-	1	-	166.8	0.6	HM	K
123	864	273063	0	3	2	2	0	-	1	-	86.4	0.75 - 1*	HM	K
124	522	451966	0	3	2	2	0	-	1	-	52.2	2.5 (1.5*)	CG (HM)	K
125	607	388675	0	3	2	2	0	-	1	-	60.7	1.5 - 1* 1.5*	HM	K
126	420	561729	0	3	2	2	0	-	1	-	42.0	1.0 (2.5*)	CG (HM)	K
127	2982	791167	-	2	1	1	0	-	1	-	29.82	2.5 3.5*	HM	K
128	2424	973292	-	2	1	1	0	-	1	-	24.24	3.5*	HM	K
129	1854	1272524	-	2	1	1	0	-	1	-	18.54	6*	HM	K
130	770	3063974	-	2	1	1	0	-	1	-	7.7	10*	HM	K
131	700	3370371	-	2	1	1	0	-	1	-	7.0	15*	HM	K
132	365	645665	0	3	2	2	0	-	1	-	36.54	2.5	Wehrle	K
133	604	390154	0	3	2	2	0	-	1	-	60.47	1.5	Wehrle	K
134	1230	191732	0	3	2	2	0	-	1	-	123.05	0.6	Wehrle	K
135	1600	1474538	-	2	1	1	0	-	1	-	16.0	10*	HM	K
139	256	921586	0	3	2	2	0	-	1	-	25.6	1.5 – 2.5	GWF	K
140	1280	1843172	-	2	1	1	0	-	1	-	12.8	3.5 – 5.0	GWF	K
141	1140	2069526	-	2	1	1	0	-	1	-	11.4	6	GWF	K
142	400	589815	-	2	1	1	-	2	-	3	4	10	GWF	K
143	320	737269	-	2	1	1	-	2	-	3	3.2	10 - 15	GWF	K
144	1280	1843172	-	1	0	0	-	2	-	3	1.28	25 - 40	GWF	K
145	640	3686344	-	1	0	0	-	2	-	3	0.64	60	GWF	K
146	128	18431719	-	1	0	0	-	2	-	3	0.128	125	GWF	K
152	1194	1975930	-	2	1	1	0	-	1	-	11.94	10	GWF	K
153	1014	2326686	-	2	1	1	0	-	1	-	10.14	15	GWF	K
156	594	397182	0	3	2	2	0	-	1	-	59.4	1.5	Metron	K
157	3764	626796	-	2	1	1	0	-	1	-	37.64	2.5	Metron	K
163	1224	192750	0	3	2	2	0	-	1	-	122.4	0.6 – 1.0	GWF/U2	K
164	852	280064	0	3	2	2	0	-	1	-	85.24	1.5	GWF/U2	K
165	599	393735	0	3	2	2	0	-	1	-	59.92	2.5	GWF/U2	K
168	449	5259161	-	2	1	1	0	-	1	-	4.486	15/25	HM/WS	K
169	1386	1702208	-	1	0	0	-	2	0	-	1.386	40	HM/WS	K
173	500	471852	-	1	0	0	-	1	-	2	0.5	80	Westland	K

Current flow reading (l/h or m³/h) is calculated on the basis of volume pulses/10 sec. (see paragraph 6.5)

\* Multi-jet water meter



3.3.9 ULTRAFLOW® X4 CCC-codes



CCC no.	Pre-counter	Flow factor	Number of decimals on the display								Pulses/l	qp [m³/h]	Type	Flow sensor
			kWh	MWh Gcal	GJ	m³ [ton]	l/h	m³/h	kW	MW				
416	3000	78642	0	3	2	2	0	-	1	-	300	0.6	65-X-CAAA-XXX 65-X-CAAD-XXX 65-X-CAAF-XXX	1-2-7-8
484	300	78642	1	-	3	3	0	-	1	-	300	0.6		1-2-7-8
419	1000	235926	0	3	2	2	0	-	1	-	100	1.5	65-X-CDA1-XXX 65-X-CDAA-XXX 65-X-CDAC-XXX 65-X-CDAD-XXX 65-X-CDAE-XXX 65-X-CDAF-XXX 65-X-CDBA-XXX	1-2-7-8
407	100	235926	1	-	3	3	0	-	1	-	100	1.5		1-2-7-8
498	600	393210	0	3	2	2	0	-	1	-	60	2.5	65-X-CEAF-XXX 65-X-CEBA/CECA-XXX 65-X-CEAD-XXX	1-2-7-8
451	5000	471852	-	2	1	1	0	-	1	-	50	3.5	65-X-CGAG-XXX 65-X-CGBB/CGCB-XXX	1-2-7-8
436	500	471852	0	3	2	2	0	-	1	-	50	3.5		1-2-7-8
437	2500	943704		2	1	1	0		1		25	6	65-X-CHAF-XXX 65-X-CHAG-XXX 65-X-CHAH-XXX 65-X-CHBB/CHCB-XXX	1-2-7-8
438	250	943704	0	3	2	2	0	-	1	-	25	6		1-2-7-8
478	1500	1572840	-	2	1	1	0	-	1	-	15	10	65-X-CJAJ-XXX 65-X-CJB2/CJC2-XXX 65-X-CJBD/CJCD-XXX	1-2-7-8
483	150	1572840	0	3	2	2	0	-	1	-	15	10		1-2-7-8
420	1000	2359260	-	2	1	1	0	-	1	-	10	15	65-X-CKB4/CKC4-XXX 65-X-CKBE/CKCE-XXX	1-2-7-8
485	100	2359260	0	3	2	2	0	-	1	-	10	15		1-2-7-8
479	600	3932100	-	2	1	1	0	-	1	-	6	25	65-X-CLBG/CLCG-XXX	1-2-7-8
458	5000	471852	-	1	0	0	-	2	0	-	5	40	65-X-CMBH/CMCH-XXX 65-X-CMBJ/CMCJ-XXX	1-2-7-8
486	500	471852	-	2	1	1	-	2	0	-	5	40		1-2-7-8
470	2500	943704	-	1	0	0	-	2	-	3	2.5	60	65-X-FACL-XXX	1-2-7-8
487	250	943704	-	2	1	1	-	2	-	3	2.5	60		1-2-7-8
480	1500	1572840	-	1	0	0	-	2	-	3	1.5	100	65-X-FBCL-XXX	1-2-7-8
488	150	1572840	-	2	1	1	-	2	-	3	1.5	100		1-2-7-8
447	1000	2359260		1	0	0		2		3	1	150	65-X-FCCN-XXX	1-2-7-8
489	100	2359260		2	1	1		2		3	1	150		1-2-7-8
481	600	3932100		1	0	0		2		3	0.6	250	65-X-FDCN-XXX	1-2-7-8
491	400	589815		1	0	0		1		2	0.4	400	65-X-FECN-XXX 65-X-FECP-XXX 65-X-FECP-XXX	1-2-7-8
492	250	943704		1	0	0		1		2	0.25	600	65-X-FFCP-XXX 65-X-FFCR-XXX	1-2-7-8
493	150	1572840		1	0	0		1		2	0.15	1000	65-X-FGCR-XXX	1-2-7-8

ULTRAFLOW® CCC- codes with high resolution

### 3.4 Display coding

The display code "DDD" indicates the active readings for the individual meter type. "1" is the first primary reading whereas e.g. "1A" is the first secondary reading. The display automatically returns to reading "1" after 4 minutes.

				Date stamp	Heat meter DDD=260	Cooling meter DDD=560	Heat/cooling DDD=660
<b>1.0</b>	<b>Heat energy (E1)</b>				<b>1</b>		<b>1</b>
		1.1	Yearly data	•	1A		1A
		1.2	Monthly data	•	1B		1B
<b>2.0</b>	<b>Cooling energy (E3)</b>					<b>1</b>	<b>2</b>
		2.1	Yearly data	•		1A	2A
		2.2	Monthly data	•		1B	2B
<b>3.X</b>		3.1	E2				
		3.2	E4				
		3.3	E5				
		3.4	E6				
		3.5	E7				
		3.6	E8 (m3*tf)				
		3.7	E9 (m3*tr)				
<b>4.0</b>	<b>Volume V1</b>				<b>2</b>	<b>2</b>	<b>3</b>
		4.1	Yearly data	•	2A	2A	3A
		4.2	Monthly data	•	2B	2B	3B
		4.3	Mass 1				
		4.4	P1				
		4.5	Meter factor for V1 (iL or Li) (N° 90)		2C	2C	3C
		4.6	Nominal flow qp (N° 92)		2D	2D	3D
<b>5.0</b>	<b>Volume V2</b>				<b>3</b>	<b>3</b>	
		5.1	Yearly data	•	3A	3A	
		5.2	Monthly data	•	3B	3B	
		5.3	Mass 2				
		5.4	P2				
		5.5	Meter factor for V2 (iL or Li) (N° 91)		3C	3C	
		5.6	Nominal flow qp (N° 93)		3D	3D	
<b>6.0</b>	<b>Hour counter</b>				<b>11</b>	<b>11</b>	<b>11</b>
		6.1	Error hour counter (N° 60)		11A	11A	11A
<b>7.0</b>	<b>T1 (Flow)</b>				<b>6</b>	<b>6</b>	<b>6</b>
		7.1	Year-to-date average		6A	6A	6A
		7.2	Month-to date average		6B	6B	6B
<b>8.0</b>	<b>T2 (Return flow)</b>				<b>7</b>	<b>7</b>	<b>7</b>
		8.1	Year-to-date average		7A	7A	7A
		8.2	Month-to-date average		7B	7B	7B
<b>9.0</b>	<b>T1-T2 (Δt) - = cooling</b>				<b>8</b>	<b>8</b>	<b>8</b>
<b>10.0</b>	<b>T3</b>						
<b>11.0</b>	<b>T4 (prog.)</b>						
<b>12.0</b>	<b>Flow (V1)</b>				<b>5</b>	<b>5</b>	<b>5</b>
		12.1	Max this year	•	5A	5A	5A
		12.2	Max. yearly data	•	5B	5B	5B
		12.3	Min. this year	•			
		12.4	Min. yearly data	•			
		12.5	Max. this month	•	5C	5C	5C
		12.6	Max. monthly data	•	5D	5D	5D
		12.7	Min. this month	•			
		12.8	Min. monthly data	•			
<b>13.0</b>	<b>Flow (V2)</b>						
<b>14.0</b>	<b>Power (V1)</b>				<b>4</b>	<b>4</b>	<b>4</b>
		14.1	Max. this year	•	4A	4A	4A
		14.2	Max. yearly data	•	4B	4B	4B
		14.3	Min. this year	•			
		14.4	Min. yearly data	•			
		14.5	Max. this month	•	4C	4C	4C
		14.6	Max. monthly data	•	4D	4D	4D
		14.7	Min. this month	•			
		14.8	Min. monthly data	•			

		Date stamp	Heat meter DDD=260	Cooling meter DDD=560	Heat/cooling DDD=660
---	---	------------	-----------------------	--------------------------	-------------------------

<b>15.0</b>	<b>VA (Input A)</b>			<b>9</b>	<b>9</b>	<b>9</b>
		15.1	Meter no. VA		9A	9A
		15.2	Yearly data	•	9B	9B
		15.3	Monthly data	•	9C	9C
		15.4	L/Imp for VA (N° 65)		9D	9D
<b>16.0</b>	<b>VB (Input B)</b>				<b>10</b>	<b>10</b>
		16.1	Meter no. VB		10A	10A
		16.2	Yearly data	•	10B	10B
		16.3	Monthly data	•	10C	10C
		16.4	L/Imp for VB (N° 67)		10D	10D
<b>17.0</b>	<b>TA2</b>				<b>13</b>	<b>13</b>
		17.1	TL2		13A	13A
<b>18.0</b>	<b>TA3</b>				<b>14</b>	<b>14</b>
		18.1	TL3		14A	14A
<b>19.0</b>	<b>Info code</b>				<b>12</b>	<b>12</b>
		19.1	Info event counter		12A	12A
		19.2	Info logger (last 36 events)	•	12B	12B
<b>20.0</b>	<b>Customer number (N° 1+2)</b>				<b>15</b>	<b>15</b>
		20.1	Date		15A	15A
		20.2	Time		15B	15B
		20.3	Target date		15C	15C
		20.4	Serial no. (N° 3)		15D	15D
		20.5	Prog. (A-B-CCC-CCC) (N° 4)		15E	15E
		20.6	Config 1 (DDD-EE) (N° 5)		15F	15F
		20.7	Config 2 (FF-GG-M-N-T) (N° 6)		15G	15G
		20.8	Software edition (N° 10)		15H	15H
		20.9	Software check-sum (N° 11)		15I	15I
		20.10	Segment test		15J	15J
		20.11	Top module type (N° 20)		15K	15K
		20.12	Top module primary adr. (N° 21)		15L	15L
		20.13	Top module second. adr. (N° 22)		15M	15M
		20.14	Base module type (N° 30)		15N	15N
		20.15	Base module primary adr. (N° 31)		15O	15O
		20.16	Base module second. adr. (N° 32)		15P	15P
		Number of yearly data shown in the display (1...15)			2	2
		Number of monthly data shown in the display (1...36)			12	12

DDD=260 is the "standard code" for heat meters with meter type S6-x x xx x xx x 2xx. Please contact Kamstrup AB for other combinations. Max. number of readings of a DDD code is 110. Of these, reading of data logger counts for 4 readings. Top module no. and base module no. to be left out of account.

A complete survey of existing display codes (DDD) appears from a separate document. Please contact Kamstrup for further details.

Note: Data reading can retrieve up to 36 monthly data and up to 15 yearly data. Number of yearly and monthly data to be shown in the display is determined by the DDD code in each case.

3.4.1 Energy overview

Above energy types E1 to E9 are calculated as follows:

Formula	$\Delta\Theta$	Example of an application	Included in Application No. (see paragraph 6.2)	Register type
$E1=V1(T1-T2)k_{T1: Flow / T2: Return}$	$T1 > T2$	Heat energy (V1 in flow or return flow)	1+2+3+4+5+6+8+10	Legal Display/Data/Log
$E2=V2(T1-T2)k_{T2: Return}$	$T1 > T2$	Heat energy (V2 in return flow)	2+7	Display/Data/Log
$E3=V1(T2-T1)k_{T2: Flow / T1: Return}$	$T2 > T1$	Cooling energy (V1 in flow or return flow)	1+11	Legal Display/Data/Log
$E4=V1(T1-T3)k_{T1: Flow}$	$T1 > T3$	Flow energy	7+9+11	Display/Data/Log
$E5=V2(T2-T3)k_{T2: Flow}$	$T2 > T3$	Return energy or tap from return flow	5+7+9	Display/Data/Log
$E6=V2(T3-T4)k_{T3: Flow}$	$T3 > T4$	Tap water energy, separate	3+6	Display/Data/Log
$E7=V2(T1-T3)k_{T3: Return}$	$T1 > T3$	Return energy or tap from flow	4+8	Display/Data/Log
$E8=m^3 \times T1$	-	Average temperature in flow	See paragraph 6.2.2	Display/Data/Log
$E9=m^3 \times T2$	-	Average temperature in return		Display/Data/Log

3.5 >EE< Configuration of MULTITARIFF

SVM S6 has 2 extra registers, TA2 and TA3, that accumulates energy E1 or E3 (EE=20 accumulates volume) in parallel with the main register based on the limits programmed to tariff limits TL2 and TL3.

Example: EE=11 (power tariff)

TA2 shows the energy consumed ...



... above the power limit TL2 (but below TL3)

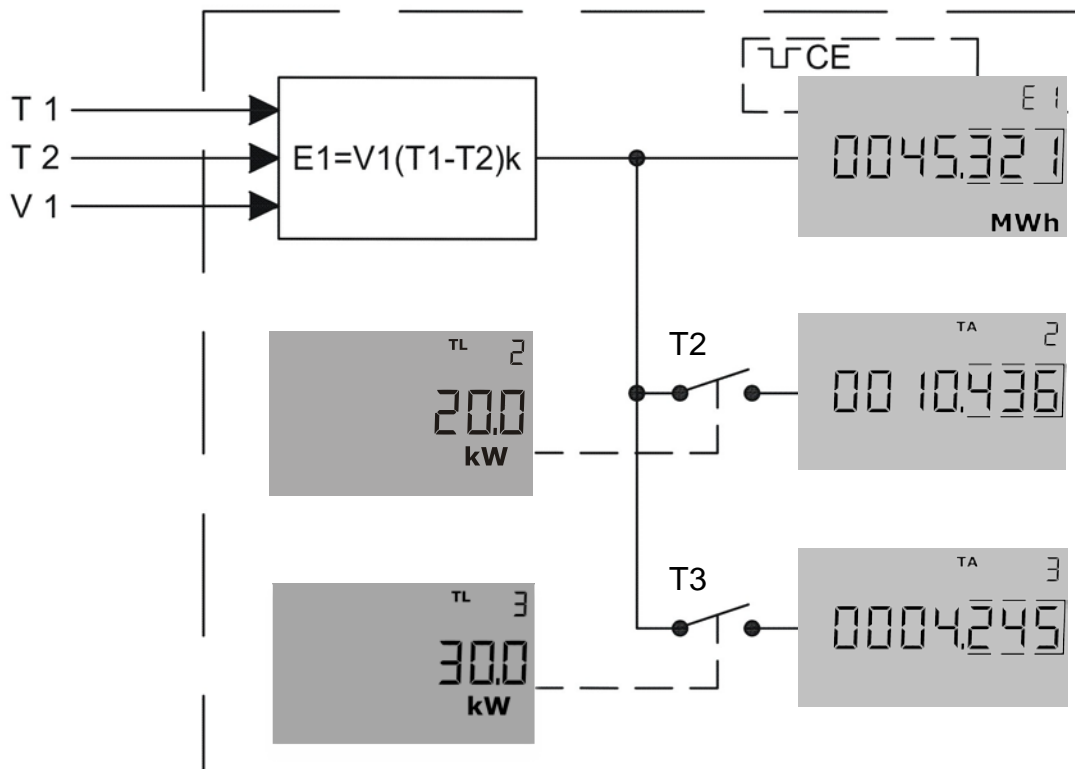

Example: Power tariff (EE=11); TL2=20 kW; TL3=30 kW; the meter is a heat meter.

The heat energy E1 is always counted in the main register. When the power exceeds the limit set for TL2, i.e. 20 kW, but is below the limit set for TL3, i.e. 30 kW, the heat energy E1 is counted in TA2, but only as long as TL2 exceeds 20 kW and is lower than 30 kW. It functions as a contact T2, which closes the moment TL2 surpasses 20 kW. As soon as the power either surpasses 30 kW or falls below 20 kW, the contact breaks again and counting stops in the TA-register. If the power surpasses 30 kW the contact T3 closes and now all the energy E1, which is consumed as long as the power remains above 30 kW is counted in T3. This energy E1 is counted in both the main register and in TA3.

EE=	TARIFF TYPE	FUNCTION	Country code 2xx	Country code 5xx	Country code 6xx
00	No tariff active	No function			
11	Power tariff	Energy is accumulated in TA2 and TA3 based on the power limits in TL2 and TL3.	•	•	
12	Flow tariff	Energy is accumulated in TA2 and TA3 based on the flow limits in TL2 and TL3.	•	•	
13	Cooling tariff	Energy is accumulated in TA2 and TA3 based on the Δt limits in TL2 and TL3.	•	•	
14	Flow temperature tariff	Energy is accumulated in TA2 and TA3 based on the tF-limits in TL2 and TL3.	•	•	
15	Return flow temperature tariff	Energy is accumulated in TA2 and TA3 based on the tR-limits in TL2 and TL3.	•	•	
19	Time-controlled tariff	TL2=Starting time for TA2 TL3=Starting time for TA3	•	•	
20	Heat/cooling volume tariff (TL2 and TL3 are not used)	Volume (V1) is split up into TA2 for heat (T1>T2) and TA3 for cooling (T1<T2) (Recommended on Heating/Cooling applications)			•
21	PQ tariff	Energy at P>TL2 is stored in TA2 and energy at Q>TL3 is stored in TA3	•	•	

Please note that only tariff No. 20 can be used in a combined heat / cooling meter. All other tariffs may only be used for either a heat meter or a cooling meter. The meter can not distinguish heat energy (E1) from cooling energy (E3) and vice versa.

See paragraph 6.12 for further details on the tariff registers.

### 3.6 >FF< Input A (VA) - pulse divider, >GG< Input B (VB) - pulse divider

SVM S6 has 2 extra pulse inputs, VA and VB, that are placed on the base modules (see paragraph 7.3 for further information). The inputs are configured via the FF and the GG codes as shown in below diagram.

By default the inputs are configured to FF = 40 and GG = 40, unless otherwise informed by the customer.

Input A Terminal 65-66		Input B Terminal 67-68		Pre-counter	Wh/pulses	l/pulse	Measuring unit and decimal point	
FF	Max. input f ≤ 1 Hz	GG	Max. input f ≤ 1 Hz					
<b>Pulse input with bounce damping (for meters with Reed-switch):</b>								
01	100 m³/h	01	100 m³/h	1	-	100	vol A/vol b (m³)	000000.0
02	50 m³/h	02	50 m³/h	2	-	50	vol A/vol b (m³)	000000.0
03	25 m³/h	03	25 m³/h	4	-	25	vol A/vol b (m³)	000000.0
04	10 m³/h	04	10 m³/h	10	-	10	vol A/vol b (m³)	000000.0
05	5 m³/h	05	5 m³/h	20	-	5.0	vol A/vol b (m³)	000000.0
06	2.5 m³/h	06	2.5 m³/h	40	-	2.5	vol A/vol b (m³)	000000.0
07	1 m³/h	07	1 m³/h	100	-	1.0	vol A/vol b (m³)	000000.0
24	10 m³/h	24	10 m³/h	1	-	10	vol A/vol b (m³)	00000.00
25	5 m³/h	25	5 m³/h	2	-	5.0	vol A/vol b (m³)	00000.00
26	2.5 m³/h	26	2.5 m³/h	4	-	2.5	vol A/vol b (m³)	00000.00
27	1 m³/h	27	1 m³/h	10	-	1.0	vol A/vol b (m³)	00000.00
40	1000 m³/h	40	1000 m³/h	1	-	1000	vol A/vol b (m³)	0000000
<b>Pulse input without bounce damping (for meters with electronic pulse output):</b>								
71	100 m³/h	71	100 m³/h	1	-	100	vol A/vol b (m³)	000000.0
72	50 m³/h	72	50 m³/h	2	-	50	vol A/vol b (m³)	000000.0
73	25 m³/h	73	25 m³/h	4	-	25	vol A/vol b (m³)	000000.0
74	10 m³/h	74	10 m³/h	10	-	10	vol A/vol b (m³)	000000.0
75	5 m³/h	75	5 m³/h	20	-	5.0	vol A/vol b (m³)	000000.0
76	2.5 m³/h	76	2.5 m³/h	40	-	2.5	vol A/vol b (m³)	000000.0
77	1 m³/h	77	1 m³/h	100	-	1.0	vol A/vol b (m³)	000000.0
84	10 m³/h	84	10 m³/h	1	-	10	vol A/vol b (m³)	00000.00
85	5 m³/h	85	5 m³/h	2	-	5.0	vol A/vol b (m³)	00000.00
86	2.5 m³/h	86	2.5 m³/h	4	-	2.5	vol A/vol b (m³)	00000.00
87	1 m³/h	87	1 m³/h	10	-	1.0	vol A/vol b (m³)	00000.00
90	1000 m³/h	90	1000 m³/h	1	-	1000	vol A/vol b (m³)	0000000
FF	Max. Input f ≤ 3 Hz	GG	Max. Input f ≤ 3 Hz	Pre-counter	Wh/pulses	l/pulses	Measuring unit and decimal point	
50	2500 kW	50	2500 kW	1	1000	-	EL A/EL b (kWh)	0000000
51	150 kW	51	150 kW	60	16.67	-	EL A/EL b (kWh)	0000000
52	120 kW	52	120 kW	75	13.33	-	EL A/EL b (kWh)	0000000
53	75 kW	53	75 kW	120	8.333	-	EL A/EL b (kWh)	0000000
54	30 kW	54	30 kW	240	4.167	-	EL A/EL b (kWh)	0000000
55	25 kW	55	25 kW	340	2.941	-	EL A/EL b (kWh)	0000000
56	20 kW	56	20 kW	480	2.083	-	EL A/EL b (kWh)	0000000
57	15 kW	57	15 kW	600	1.667	-	EL A/EL b (kWh)	0000000
58	7,5 kW	58	7,5 kW	1000	1.000	-	EL A/EL b (kWh)	0000000
59	750 kW	59	750 kW	10	100	-	EL A/EL b (kWh)	0000000
60	1250 kW	60	1250 kW	2	500	-	EL A/EL b (kWh)	0000000
61	75 kW	61	75 kW	100	10.00	-	EL A/EL b (kWh)	0000000
62	15 kW	62	15 kW	500	2.000	-	EL A/EL b (kWh)	0000000
70	25000 kW	70	25000 kW	1	10000	-	EL A/EL b (MWh)	00000.00

FF and GG are only used for configuration of inputs.

l/pulse can also be set via the front buttons. Please see 6.17 for further information.

### 3.7 Configuration of pulse outputs in the top module

See paragraph 10.1

### 3.8 »MN« Configuration of leak limits

When SVM S6 is used for leakage surveillance, the sensitivity is "M-N" in connection with configuration.

District heat leakage search (V1-V2)		Cold-water leakage search (VA)	
M=	Sensitivity in leakage search	N=	Constant leakage at no consumption (pulse resolution 10 l/pulses)
0	OFF	0	OFF
1	1.0% qp + 20% q	1	20 l/h 3x10 min. (½ hour without pulses)
<b>2</b>	<b>1.0% qp + 10% q</b>	<b>2</b>	<b>10 l/h 6x10 min. (1 hour without pulses)</b>
3	0.5% qp + 20% q	3	5 l/h 12x10 min. (2 hours without pulses)
4	0.5% qp + 10% q		

**NB:** M=2 and N=2 are default values when leakage surveillance is used. Higher degree of sensitivity, e.g. M=4 can only be obtained by means of METERTOOL.

Info codes for leakage/bursting (info 256/512) are only active when M > 0 or N > 0.

#### 3.8.1 Example of District Heat Leakage level (Leak level)

In this example M=2. Having a qp=0.6 m<sup>3</sup>/h flowmeter, qp must be converted to l/h: qp=600 l/h.

If we assume that there has been a means flow of 50 l/h then there will be counted approximately 1200 l/day. 10% of this value is 120 l/day. Further, 1% of qp=600 l/h is 6 l/h equivalent to 24 x 6 l/h = 144 l/day. Leak level in this case will be 120 + 144 = 264 l/day or equivalent of 6 l/h.

### 3.9 »T« Configuration of encryption level

SVM S6 is available without or with encryption of the data transmission. If encryption of data is selected, 128 bit AES counter mode encryption is applied. The encryption level cannot be changed after production.

Encryption level	
T=	
0	No encryption
1	Reserved for future use
2	Reserved for future use
3	Encryption with separately forwarded key (individual key)
4	Reserved for future use

#### T=0

Default value. Data has not been encrypted.

#### T=3

The meter can only be read if the reading system recognizes the individual meter's encryption key. The encryption key is forwarded to the customer and "matched" with the individual meter's serial number in the reading system.

If the encryption key is lost, the meter cannot be read. A new encryption key must be supplied by Kamstrup.

Only encrypted data via the base modules can be read by Wireless M-Bus.

### 3.10 Data for configuration

	Automatic	To be stated when ordering	Default
Serial no. (S/N) and year	E.g. 65.000.000/2012	-	-
Customer number Display No. 1 = 8 digits MSD Display No. 2 = 8 digits LSD	-	Up to 16 digits. Limited to 11 digits regarding PcBase compatibility	Customer number = S/N
Target date	-	MM=1-12 and DD=1-28	Depending on country code
TL2	-	5 digits	0
TL3	-	5 digits	0
Max./min. average peak time	-	1...1440 min.	60 min.
H/C change over ( $\theta_{hc}$ )	-	0.01...180.00 °C	25 °C at DDD=5xx and 6xx
T2 prog.		0.01...180 °C	-
T3 prog.		0.01...180 °C	5 °C
T4 prog.		0.01...180 °C	0 °C
Date/time	YYYY.MM.DD/hh.mm.ss GMT+offset according to country code	GMT ± 12.0 hours (0.5 hour in jumps)	-

#### Data registers for configuration of top/base modules

qp [l/h]	from CCC table	-	-
Valve traction time	-	20...500 sec.	300 sec.
Hysteresis	-	0.5...5 sec.	0.5 sec.
Telephone number #1	-	Max. 16 (0-9+P)	-
Telephone number #2	-	Max. 15 (0-9+P)	-
Telephone number #3	-	Max. 15 (0-9+P)	-
Primary Data Address			
Secondary Data Address			
Baud-rate			
Reserved			
Reserved			
Reserved			
.....			
Reserved			

Reserved: These registers are prepared for later extensions of the functionality of the modules and therefore, they have not yet any concrete designations.

#### - COUNTRY CODES

For information on country codes see 55 14-609.

#### - MAINTENANCE

See instruction no. 55 08-781 concerning updating of programming, configuration and country codes.

### 4 Dimentional sketches

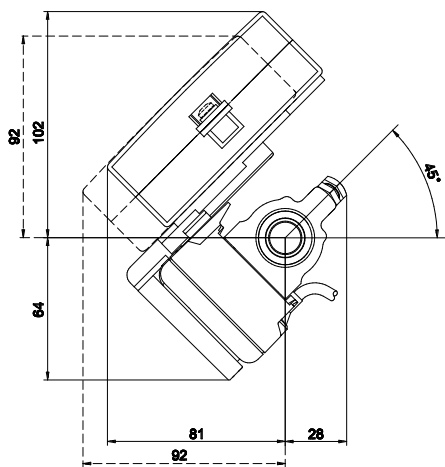

SVM S6 mounted on ULTRAFLOW®

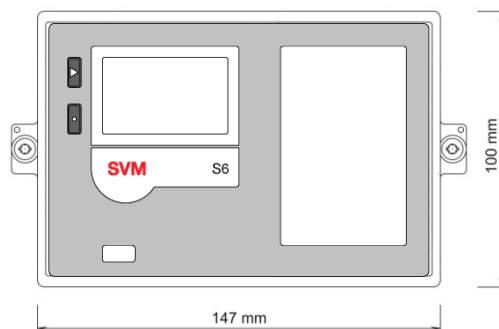

SVM S6 's front dimensions

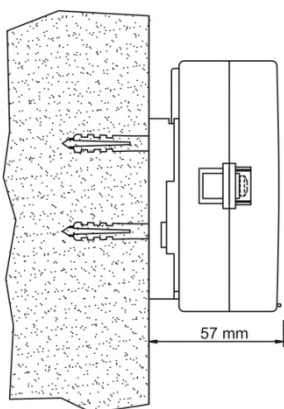

Wall-mounted SVM S6 seen from the side

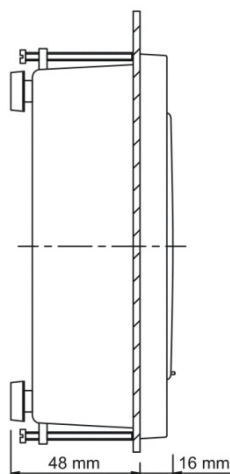

Panel-mounted SVM S6 seen from the side

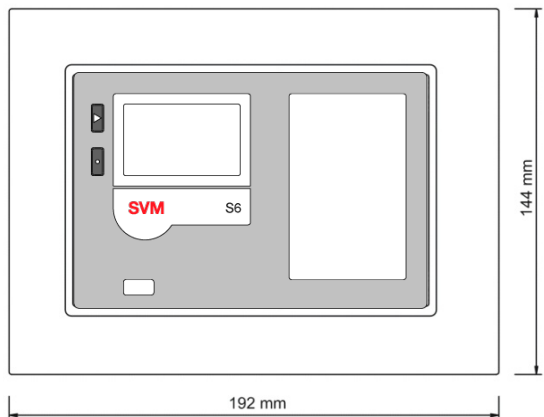

Panel-mounted SVM S6 seen from the front

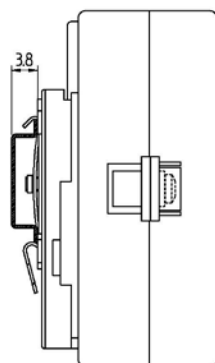

DIN rail mounting of MULTICAL® 602 is possible with a DIN rail bracket

# 5 Installation

## 5.1 Flow pipe and return pipe placing

Prog. number

A  
□

SVM S6 is programmed for flow sensor placing in either flow or return pipe. Below diagram shows the installation conditions for:

**Flow sensor placing:**

k-factor table	- Inlet/Flow pipe (at T1)	3
	- Outlet/Return pipe (at T2)	4

- ◆ Heat meters
- ◆ Cooling meters
- ◆ Heat/cooling meters

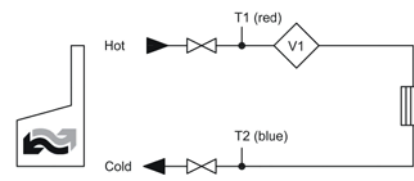
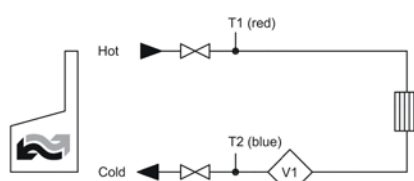
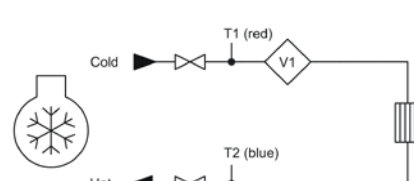
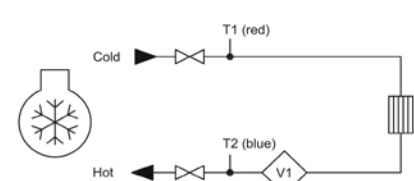
Formula:	k-factor	Prog.:	Hot pipe	Cold pipe	Installation:
<b>Heat meter</b> $E1=V1(T1-T2)k$	k-factor with T1 in Inlet table	A=3 (Flow sensor in Flow pipe)	V1 and T1	T2	
	k-factor with T2 in Outlet table	A=4 (Flow sensor in Return pipe)	T1	V1 and T2	
<b>Cooling meter</b> $E3=V1(T2-T1)k$	k-factor with T1 in Outlet table	A=3 (Flow sensor in Flow pipe)	T2	V1 and T1	
	k-factor with T2 in Inlet table	A=4 (Flow sensor in Return pipe)	V1 and T2	T1	

## 5.2 EMC conditions

SVM S6 is designed and CE marked in accordance with EN 1434 Class A and Class C (corresponding to Electromagnetic environment: Class E1 and E2 in the Measuring Instruments Directive) and can therefore be installed in domestic and industrial environments.

All control cables must be installed separately and not in parallel with e.g. power cables or other cables with the risk of induction of electromagnetic interferences. Control cables are laid at a min. distance of 25 cm from other installations.

## 5.3 Climatic conditions

SVM S6 is designed for indoor installation in noncondensing environments with ambient temperatures from 5...55 °C, however, max. 30 °C for optimal battery lifetime.

Protection class IP54 allows periodic splashes of water, but the apparatus cannot stand constant moisture and flooding.

## 5.4 Electric installations

See paragraph 9.

## 6 Calculator functions

### 6.1 Energy calculation

SVM S6 calculates energy based on the formula in EN 1434-1:2007 in which the international temperature scale from 1990 (ITS-90) and the pressure definition of 16 bar is used.

The energy calculation can in a simplified way be expressed as:  $Energy = V \times \Delta\Theta \times k$ .

The calculator always calculates energy in [Wh], and then it is converted into the selected measuring unit.

E [Wh] =	$V \times \Delta\Theta \times k \times 1000$
E [kWh] =	$E [Wh] / 1,000$
E [MWh] =	$E [Wh] / 1,000,000$
E [GJ] =	$E [Wh] / 277,780$
E [Gcal] =	$E [Wh] / 1,163,100$

**V** is the supplied (or simulated) water volume in m<sup>3</sup>. E.g. if a CCC code = 119 is used, the calculator will be programmed to receive 100 pulses/liter. E.g. if 10,000 pulses are added this corresponds to 10,000/100 = 100 liters or 0.1 m<sup>3</sup>.

**ΔΘ** is the temperature difference measured, e.g. ΔΘ = flow temperature – return flow temperature. Please note, that various temperatures are used to calculate ΔΘ as SVM S6 calculates various different energy types. Both in the display and during data reading each energy type is uniquely defined, e.g.:

Heat energy:  $E1 = V1(T1-T2)k$

Cooling energy:  $E3 = V1 (T2-T1)k$



**k** is the thermal coefficient of water which is calculated on the basis of formula in EN 1434-1:2007 (identical with the energy formula in OIML R75-1:2002). For control calculations Kamstrup SMV AB can supply an energy calculator:

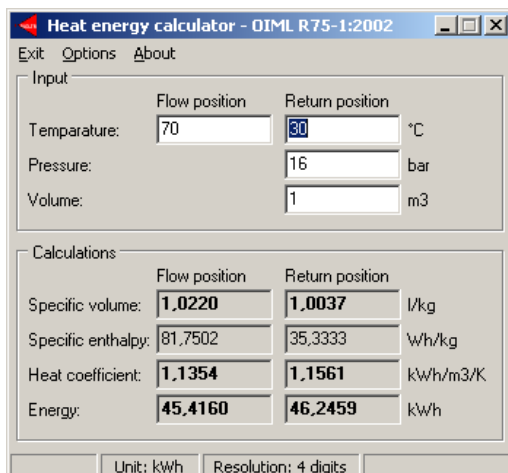

### 6.2 Application types

SVM S6 operates with 9 different energy formulas, E1...E9, that are all calculated in parallel with each integration no matter how the meter is configured.

Formula	$\Delta\Theta$	Example of an application	Included in Application No.	Register type
$E1=V1(T1-T2)k_{T1: Flow / T2: Return}$	$T1 > T2$	Heat energy (V1 in flow or return flow)	1+2+3+4+5+6+8+10	Legal Display/Data/Log
$E2=V2(T1-T2)k_{T2: Return}$	$T1 > T2$	Heat energy (V2 in return flow)	2+7	Display/Data/Log
$E3=V1(T2-T1)k_{T2: Flow / T1: Return}$	$T2 > T1$	Cooling energy (V1 in flow or return flow)	1+11	Legal Display/Data/Log
$E4=V1(T1-T3)k_{T1: Flow}$	$T1 > T3$	Flow energy	7+9+11	Display/Data/Log
$E5=V2(T2-T3)k_{T2: Flow}$	$T2 > T3$	Return energy or tap from return flow	5+7+9	Display/Data/Log
$E6=V2(T3-T4)k_{T3: Flow}$	$T3 > T4$	Tap water energy, separate	3+6	Display/Data/Log
$E7=V2(T1-T3)k_{T3: Return}$	$T1 > T3$	Return energy or tap from flow	4+8	Display/Data/Log
$E8=m^3 \times T1$	-	Average temperature in flow	See paragraph 6.2.2	Display/Data/Log
$E9=m^3 \times T2$	-	Average temperature in return		Display/Data/Log

#### 6.2.1 E1...E7

The energy types E1...E7 are described with application examples below.

<p style="text-align: center;">S6-A/B/C/D</p>	<p><b>Application No. 1</b></p> <p><b>Closed thermal system with 1 flow sensor</b></p> <p>Heat energy: <math>E1 = V1(T1-T2)k_{T1:Flow \text{ or } T2:Return}</math></p> <p>Cooling energy: <math>E3 = V1(T2-T1)k_{T2:Flow \text{ or } T1:Return}</math></p> <p>Flow sensor V1 is placed in flow or return pipe as chosen under PROG options.</p> <p>Mass: <math>M1 = V1(Kmass \ t1)</math> or                  Mass: <math>M1 = V1(Kmass \ t2)</math> depending on the Flow/Return programming</p>
<p style="text-align: center;">S6-C</p>	<p><b>Application No. 2</b></p> <p><b>Closed thermal system with 2 identical flow sensors</b></p> <p>Billing energy: <math>E1 = V1(T1-T2)k_{T1:Flow}</math></p> <p>Control energy: <math>E2 = V2(T1-T2)k_{T2:Return}</math></p> <p>T3 can be used for control measurement of either the flow or return temperature, but T3 is not included in calculations.</p> <p>Mass: <math>M1 = V1(Kmass \ t1)</math>                  Mass: <math>M2 = V2(Kmass \ t2)</math></p>

<p style="text-align: center;">S6-C</p>	<p><b>Application No. 3</b></p> <p><b>2 string system with 2 flow sensors</b></p> <p>Heat energy: <math>E1 = V1(T1-T2)k_{T1:Flow \text{ or } T2:Return}</math></p> <p>Tap water energy: <math>E6 = V2(T3-T4)k_{T3:Flow}</math></p> <p>T3 is measured or programmed T4 is programmed</p> <p>Flow sensor V1 is placed in flow or return pipe as chosen under PROG options.</p> <p>Mass: <math>M1 = V1(Kmass \ t1)</math> or Mass: <math>M1 = V1(Kmass \ t2)</math> depending on the Flow/Return programming Mass: <math>M2 = V2(Kmass \ t3)^*</math></p>
<p style="text-align: center;">S6-C</p>	<p><b>Application No. 4</b></p> <p><b>2 heat circuits with joint flow</b></p> <p>Heat energy #1: <math>E1 = V1(T1-T2)k_{T2:Return}</math></p> <p>Heat energy #2: <math>E7 = V2(T1-T3)k_{T3:Return}</math></p> <p>T3 is measured or programmed Mass: <math>M1 = V1(Kmass \ t2)</math> Mass: <math>M2 = V2(Kmass \ t3)^*</math></p>
<p style="text-align: center;">S6-C</p>	<p><b>Application No. 5</b></p> <p><b>Open system with tap from return flow</b></p> <p>Heat energy: <math>E1 = V1(T1-T2)k_{T1:Flow}</math></p> <p>Tap water energy: <math>E5 = V2(T2-T3)k_{T2:Flow}</math></p> <p>T3 is measured or programmed.</p> <p>Mass: <math>M1 = V1(Kmass \ t1)</math> Mass: <math>M2 = V2(Kmass \ t2)</math></p>

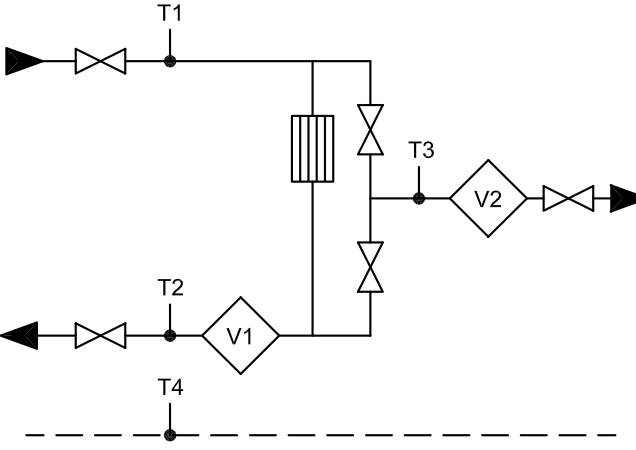
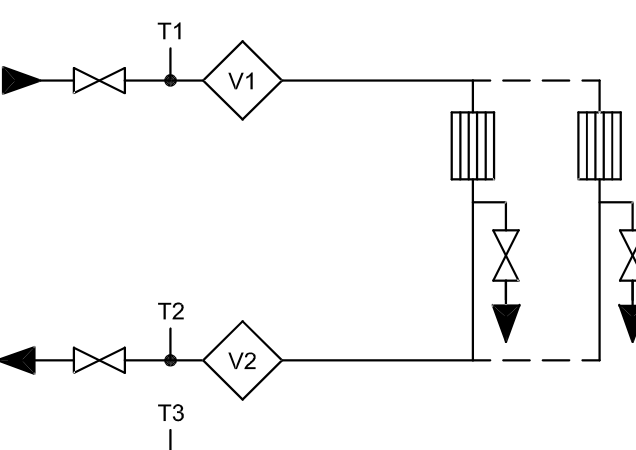
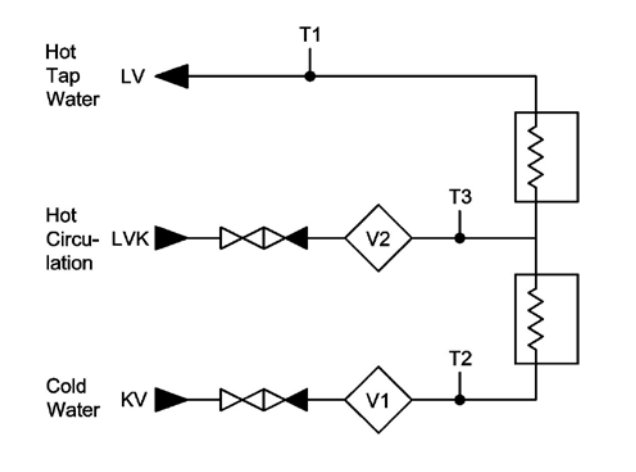
 <p style="text-align: center;">S6-C</p>	<p><b>Application No. 6</b></p> <p><b>Open system with separate flow sensor for tap water</b></p> <p>Heat energy: <math>E1 = V1(T1-T2)k_{T2:Return}</math></p> <p>Tap water energy: <math>E6 = V2(T3-T4)k_{T3:Flow}</math></p> <p>T3 is measured or programmed T4 is programmed</p> <p>Mass: <math>M1 = V1 (K_{mass} t2)</math> Mass: <math>M2 = V2 (K_{mass} t3)^*</math></p>
 <p style="text-align: center;">S6-C</p>	<p><b>Application No. 7</b></p> <p><b>Open system with 2 flow sensors</b></p> <p>Flow energy: <math>E4 = V1(T1-T3)k_{T1:Flow}</math></p> <p>Return energy: <math>E5 = V2(T2-T3)k_{T2:Flow}</math></p> <p>(<math>\Delta E = E4-E5</math> can be calculated by the topmodule, but only if the 2 flow sensors are identical)</p> <p>Heat energy: <math>E2 = V2(T1-T2)k_{T2:Return}</math></p> <p>T3 is measured or programmed.</p> <p>Mass: <math>M1 = V1 (K_{mass} t1)</math> Mass: <math>M2 = V2 (K_{mass} t2)</math></p>
 <p style="text-align: center;">S6-C</p>	<p><b>Application No. 8</b></p> <p><b>Hot-water boiler with circulation</b></p> <p>Total consumption: <math>E1 = V1(T1-T2)k_{T2:Return}</math></p> <p>Circulated consumption: <math>E7 = V2(T1-T3)k_{T3:Return}</math></p>

\*  $M2 = V2 (K_{mass} t3)^*$  only on selected country codes (930...939)!

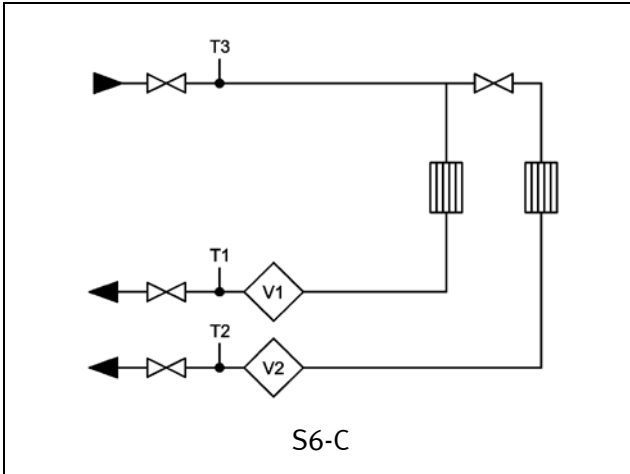

**Application No. 9**

**2 cooling circuits with joint flow**

Cooling energy #1:  $E_4 = V_1(T_1-T_3)k_{T_1:Flow}$

Cooling energy #2:  $E_5 = V_2(T_2-T_3)k_{T_2:Flow}$

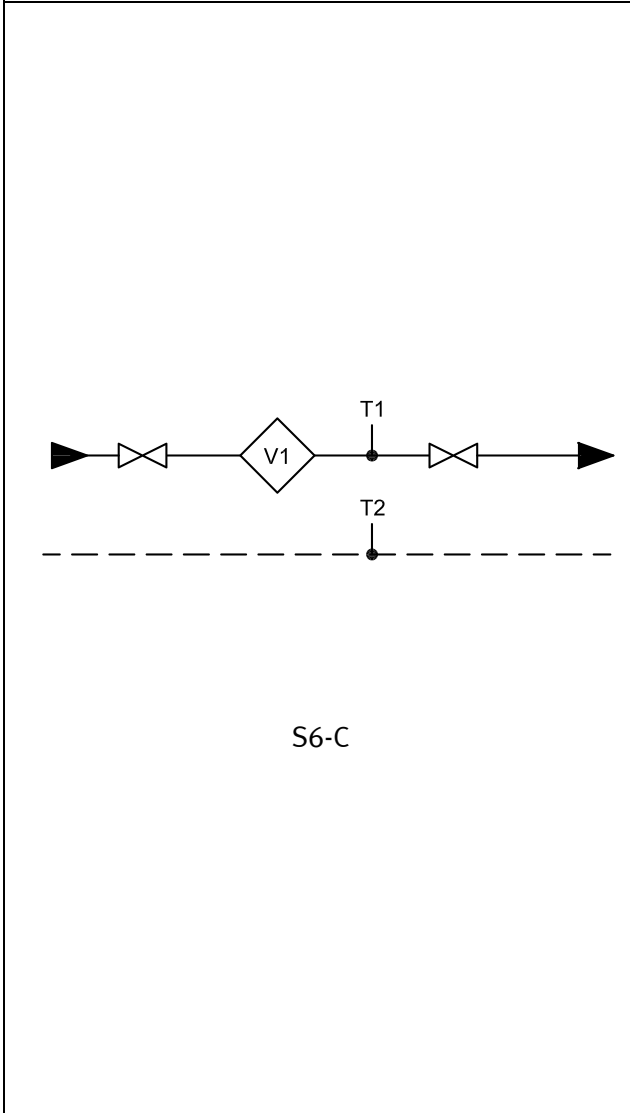

**Application No. 10**

**Hot tap water energy:  $E_1 = V_1 (T_1-T_2)K_{T_1:Flow}$**

T1 is measured with a 2-wire sensor (S6-C) or with a 4-wire sensor (602-B/D)

T2 is either measured with a 2-wire sensor (S6-C) or with a 4-wire sensor (S6-B/D)

Or

T2 is programmed with a fixed temperature value

Or

T2 is programmed via the scheduler and hourly datalogger top module, type 602-0A. The temperature T2 will then follow a schedule where T2 changes up to 12 times per year.

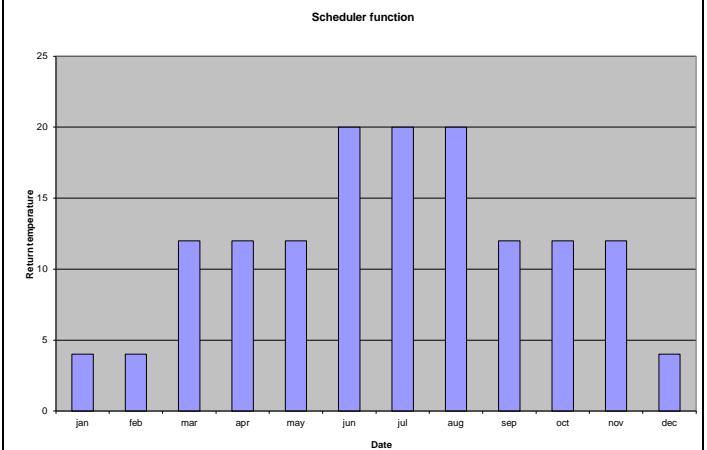

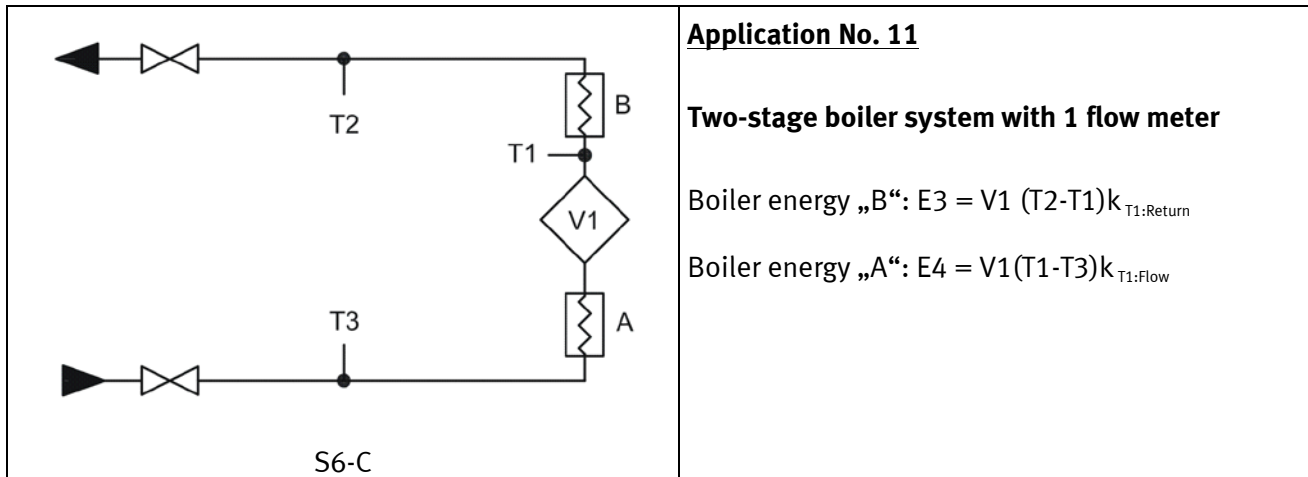

**Application No. 11**

**Two-stage boiler system with 1 flow meter**

Boiler energy „B“:  $E3 = V1 (T2-T1)k_{T1:Return}$

Boiler energy „A“:  $E4 = V1(T1-T3)k_{T1:Flow}$

**6.2.2 E8 and E9**

E8 and E9 are used as calculation basis for calculating volume based average temperatures in flow and return pipe, respectively. For each integration (every 0.01 m<sup>3</sup> for qp 1.5 m<sup>3</sup>/h) the registers are accumulated with the product of m<sup>3</sup> × °C, for such purposes E8 and E9 is a suitable basis for calculating volume based average temperatures.

E8 and E9 can be used for average calculation in any period of time as long as the volume register is read at the same time as E8 and E9.

**E8 = m<sup>3</sup> × t<sub>f</sub>** E8 is accumulated with the product of m<sup>3</sup> × t<sub>f</sub> **E9 = m<sup>3</sup> × t<sub>r</sub>** E9 is accumulated with the product of m<sup>3</sup> × t<sub>r</sub>



**Resolution on E8 and E9**

E8 and E9 are depending on the volume resolution (m<sup>3</sup>)

Volume resolution	E8 and E9 resolution
0000.001 m <sup>3</sup>	m <sup>3</sup> × °C × 10
00000.01 m <sup>3</sup>	m <sup>3</sup> × °C
000000.1 m <sup>3</sup>	m <sup>3</sup> × °C × 0.1
0000001 m <sup>3</sup>	m <sup>3</sup> × °C × 0.01

**Example 1:** After 1 year a heat installation has consumed 250.00 m<sup>3</sup> of district heating water and the average temperatures have been 95 °C in flow and 45°C in return pipe.  
E8 = 23750 and E9 = 11250.

**Example 2:** It is required that the average temperatures are measured at the same time as the yearly reading, and therefore E8 and E9 are included in the yearly reading.

Reading date	Volume	E8	Average flow	E9	Average return flow
2003.06.01	534.26 m <sup>3</sup>	48236		18654	
2002.06.01	236.87 m <sup>3</sup>	20123		7651	
Yearly consumption	297.39 m <sup>3</sup>	28113	28113/297.39 = <b>94.53°C</b>	11003	11003/297.39 = <b>36.99°C</b>

Table 1

### 6.3 Calculator with two flow sensors

SVM S6 can be used in various applications with two flow sensors, e.g. leak surveillance or open systems. When two ULTRAFLOW® are direct connected to one SVM S6, a close electric coupling between the two pipes ought to be carried out as a main rule. If the two pipes are installed in a heat exchanger, close to the flow sensors, however, the heat exchanger will provide the necessary electric coupling.

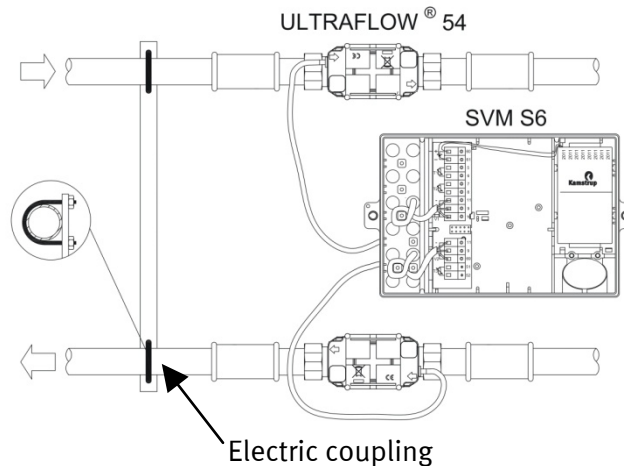

- Forward and return pipes are closely electrically coupled
- No welded joints occur

In installations where the electric coupling cannot be carried out, or where welding in the pipe system can occur, the cable from one ULTRAFLOW® must be routed through a Pulse Transmitter with galvanic separation before the cable enters SVM S6.

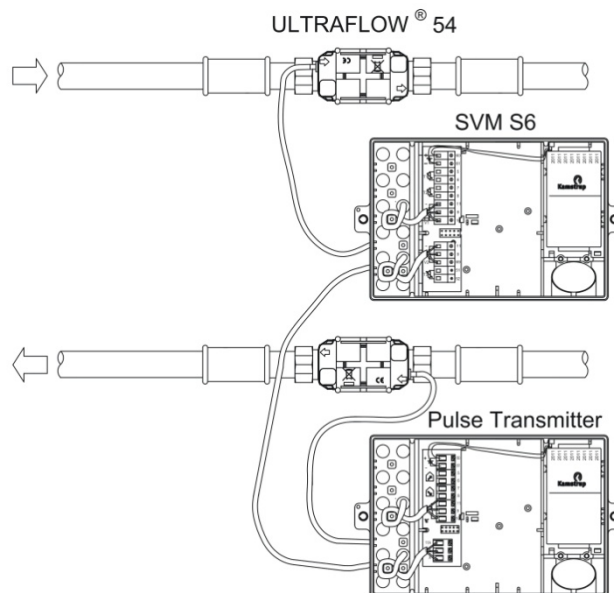

- Forward and return pipes are not necessarily closely coupled
- Electric welding <sup>\*)</sup> can occur

<sup>\*)</sup> Electric welding must always be carried out with the earth pole closest to the welding point. Damage to meters due to welding is **not** comprised by our factory guarantee.

### 6.4 Combined heat/cooling metering

SVM S6 is available as e.g. heat meter (Meter type 2xx), cooling meter (Meter type 5xx) or combined heat/cooling meter (Meter type 6xx).

Meter type		
Heat meter with MID marking	2	
Cooling meter	5	
Heat/cooling meter	6	
Delivery code (language on label etc.)		XX

If SVM S6 has been supplied as a combined heat/cooling meter (meter type 6xx), it measures heat energy (E1) at a positive temperature difference (T1 > T2), whereas it measures cooling energy (E3) at a negative temperature difference (T2 > T1). Temperature sensor T1 (with a red type sign) must be installed in the hydraulic forward pipe, whereas T2 (with a blue type sign) is installed in the return pipe.

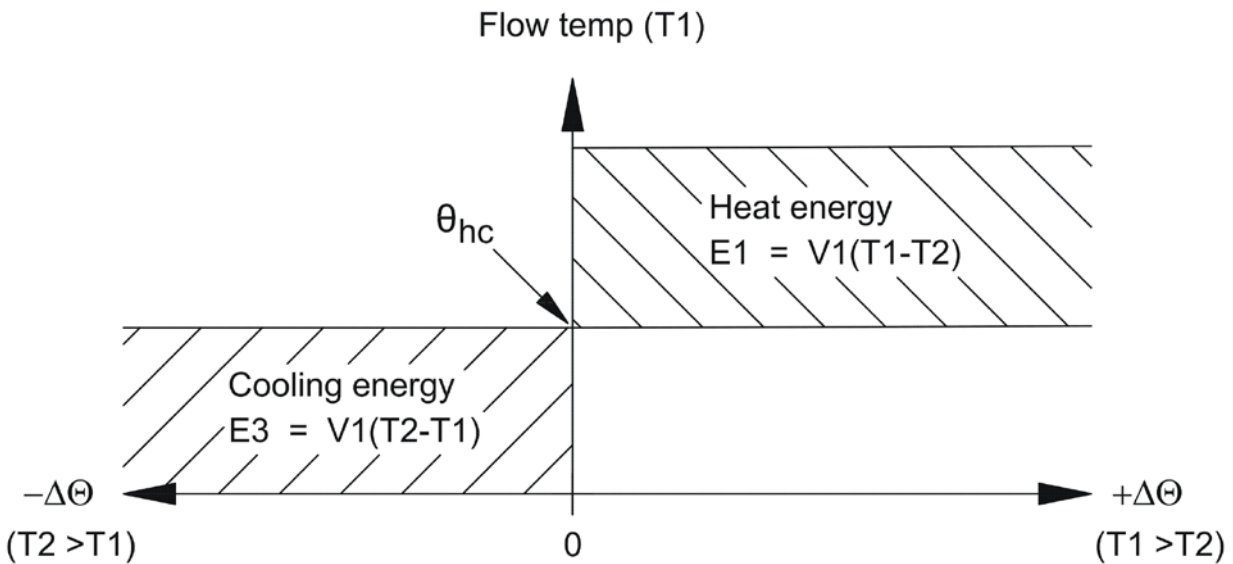

If the current T1 exceeds, or equals  $\theta_{hc}$  only heat energy can be measured. If the current T1 is lower than or equals  $\theta_{hc}$  only cooling energy can be measured.

$\theta_{hc}$  is the temperature point used to change between heat and cooling measurement.  $\theta_{hc}$  is configurable in temperature range 0.01...180.00 °C.

In combined heat/cooling meters  $\theta_{hc}$  should correspond to the highest occurring flow pipe temperature in connection with cooling, e.g. 25 °C. If the meter is to be used for "purchase and sale of heat",  $\theta_{hc}$  is set at 200.00 °C, which cancels the  $\theta_{hc}$  function.

The change between heat and cooling measurement involves no hysteresis ( $\Delta\theta_{hc} = 0.00K$ ).

$\theta_{hc}$  is configured by means of METERTOOL (see paragraph 13.2).  $\theta_{hc}$  is also mentioned as H/C change-over.

## 6.5 Flow measurement, V1 and V2

SVM S6 calculates current water flow according to two different principles depending on the connected flow sensor type:

### 6.5.1 Fast volume pulses (CCC > 100)

The current water flow for fast volume pulses is calculated, without average determination, as the number of volume pulses per 10 sec. multiplied by a scaling factor.

$$q = (\text{pulses}/10 \text{ sec.} \times \text{flow factor})/65535 \text{ [l/h] or [m}^3\text{/h]}$$

Example:

- ULTRAFLOW<sup>®</sup> qp 1.5 m<sup>3</sup>/h with 100 pulses/l (CCC=119), flow factor = 235926
- Current water flow = 317 l/h corresponding to 88 pulses/10 sec.

$$q = (88 \times 235926)/65535 = 316.8 \text{ which is shown in the display as 316 [l/h]}$$

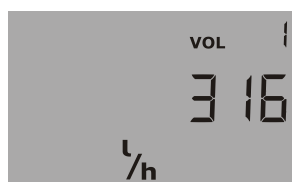

Current water flow in V1

### 6.5.2 Resolution of the actual flow rate (CCC > 100)

The display resolution of the actual flow rate can be derived from the flow factor and the number of decimals.

Example 1:

- ULTRAFLOW<sup>®</sup> qp 1.5 m<sup>3</sup>/h with 100 pulses/l (CCC=119), flow factor = 235926

$$\text{Resolution} = 235926/65535 = 3.6 \text{ which is shown in the display as 3 [l/h]}$$

Example 2:

- FUS380 Qs 75 m<sup>3</sup>/h with 1 pulses/l (CCC=201), flow factor = 235926

$$\text{Resolution} = 235926/65535 = 3.6 \text{ which is shown in the display as 3.6 [m}^3\text{/h]}$$

### 6.5.3 Slow volume pulses (CCC = 0XX)

The current water flow for slow volume pulses (typically from flow sensors with a Reed switch) is calculated without average determination as a scaling factor divided by the period of time between two volume pulses.

$$q = \text{flow factor}/(256 \times \text{period in sec.}) \text{ [l/h] or [m}^3\text{/h]}$$

Example:

- Mechanical flow sensor Qn 15 qp m<sup>3</sup>/h with 25 l/pulse (CCC=021), flow factor = 230400
- Current water flow = 2.5 m<sup>3</sup>/h corresponding to 36 sec. in the period of time between 2 pulses

$$q = 230400/(256 \times 36) = 25, \text{ which is shown in the display as 2.5 [m}^3\text{/h]}$$

V1 and V2 must be the same type (either quick (CCC > 100) or slow (CCC=0XX)) but can have different qp-codings (CCC).

Using top modules 67-02 or 67-09, V1 and V2 must have identical qp-codings (CCC).

The actual flow rate on the display will be shown a "0", when the period between pulses exceed 15 min.

### 6.6 Power measurement, V1

SVM S6 calculates the current power based on the current water flow and the temperature difference measured at the last integration based on following formula:

$$P = q (T1 - T2) \times k \text{ [kW] or [MW]}$$

where "k" is the water's heat coefficient that is constantly calculated by SVM S6 according to EN 1434:2007.

Example:

- Current water flow, q = 316 l/h and flow sensor is placed in return pipe
- T1 = 70.00 °C and T2 = 30.00 °C, k-factor is calculated for 1.156 kWh/m<sup>3</sup>/K

$$P = 0.316 (70-30) \times 1.156 = 14.6 \text{ [kW]}$$



Current power in V1

Both heat power and cooling power are shown numerically

### 6.7 Min. and max. flow and power, V1

SVM S6 registers both minimum and maximum flow and power both on a monthly and on a yearly basis. These values can be read in full via data communication. In addition, a small number of monthly and yearly registers can be read on the display depending on the selected DDD code.

Min. and Max. registration comprises following flow and power values including date.

Registration type:	Max. data	Min. data	Yearly data	Monthly data
Max. this year (since last target date)	•		•	
Max. yearly data, up to 15 years back	•		•	
Min. this year (since last target date)		•	•	
Min. yearly data, up to 15 years back		•	•	
Max. this month (since last target date)	•			•
Max. monthly data, up to 36 months back	•			•
Min. this month (since last target date)		•		•
Min. monthly data, up to 36 months back		•		•

All max. and min. values are calculated as largest and smallest average of a number of current flow or power measurements. The average period used for all calculations are selected in the interval 1...1440 min. in jumps in 1 min. (1440 min. = 1 full day).

The average period and target date are stated in connection with orders or re-configured by means of METERTOOL. Where nothing has been stated when the order was placed the average period is set at 60 min. and the target date is set at the standard applying for the country code used.

In connection with commencement of a new year or month the max. and min. values are stored in the data logger and the current max. and min. registers are "reset" according to the selected target date and the internal clock and calendar of the meter.

"Reset" is made by putting the max. value at zero and min. value at 10000.0 kW at e.g. CCC=119.

Date for year-to-date max.



Value for year-to-date max.



Date for min. in the current month

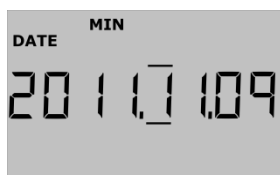

Value for min. in the current month



### 6.8 Temperature measurement

SVM S6 has a high resolution analog/digital converter that measures the temperatures T1, T2 and T3 with a resolution of 0.01 °C (T3 is not available on meters with 4-wire sensor inputs). The same measuring circuit is used for all 3 temperature inputs to obtain the lowest possible measuring error on the temperature difference. Prior to each temperature measurement an automatic adjustment of the internal measuring circuit is made on the basis of integral reference resistances at 0 °C and 100 °C, respectively. This ensures a very good accuracy and a very stable long-term operation.

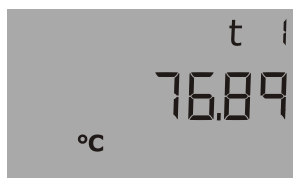

Current T1

Temperature measurements are made in connection with each integration (energy calculation) and every 10 sec. when the display shows temperature. The measuring circuit has a temperature range of 0.00 °C...185.00 °C. In case of a disconnected temperature sensor the display shows 200.00 °C and in connection with a short-circuited temperature sensor it shows 0.00 °C. In both cases the info code for sensor error will appear.

To reduce the influence from the mains frequency which can e.g. be inducted to long sensor cables, double measurements are made with a delay of 1/2 period, and the average of the 2 measurements make up the temperature measurement used for calculation and display. Suppressing of the mains frequency is optimised to either 50 Hz or 60 Hz depending on the selected country code.

#### 6.8.1 Measuring current and power

Measuring current is only sent through the temperature sensors in the short period of time it takes to measure the temperature. However, the effective power that is consumed in the sensor elements is minimal and the influence on the self-heating of the temperature sensors is typically less than 1/1000 K.

	<b>Pt100</b>	<b>Pt500</b>
<b>Testing current</b>	< 3 mA	< 0.5 mA
<b>Peak power</b>	< 1.5 mW	< 0.2 mW
<b>RMS power</b>	< 10 µW	< 1 µW

**6.8.2 Average temperatures**

SVM S6 constantly calculates the average temperatures for flow and return (T1 and T2) in the entire °C range and the background calculations E8 and E9 (m<sup>3</sup> x T1 and m<sup>3</sup> x T2) are made for each energy calculation (e.g. for each 0.01 m<sup>3</sup> for qp 1.5 meter size), whereas the display value is updated every day. Thereby the average calculations are weighted according to volume and can therefore be used for control purposes.

<i>Registration type:</i>	<i>Average</i>	<i>Yearly data</i>	<i>Monthly data</i>
<i>Year-to-date average (since last target date)</i>	•	•	
<i>Month-to-date average (since last target date)</i>	•		•

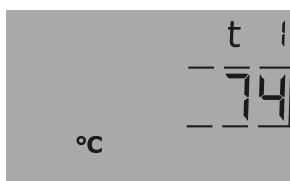

Year-to-date average for T1.

(Current date with "comma lines" under year or month is shown just BEFORE this reading)

**6.8.3 Programmed temperatures**

The temperatures T3 and T4 can be programmed in the memory of the calculator, and these temperatures can be used for calculating energy with fixed temperature reference, as used in connection with the calculations of the energy types E4, E5, E6 and E7 (see the application drawings in paragraph 6.2)

The temperatures can be programmed when placing orders or by means of METERTOOL in the range 0.01...180°C, once the meter is installed.

### 6.9 Display functions

SVM S6 is equipped with a clear LC display including 8 digits, units of measurement and information panel. In connection with energy and volume readings 7 digits and the corresponding units of measurement are used, whereas 8 digits are used when e.g. a meter number is shown.

As a starting point the display shows the accumulated energy. When the push buttons are activated the display reacts immediately by showing other readings. The display automatically returns to energy reading 4 minutes after last activation of the push buttons.



#### 6.9.1 Primary and secondary readings

The upper button is used to switch between the primary readings of which the consumers typically use the first primary readings in connection with self-reading for billing purposes.

The lower push button is used to show secondary information on the primary reading that has been selected.

Example: When the primary reading selected is "Heat energy" the secondary readings will be yearly data and monthly data for heat energy.

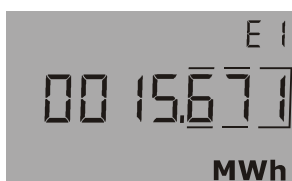

Heat energy E1 in MWh



Yearly data, date for LOG 1 (last yearly reading)



Yearly data, value for LOG 1 (last yearly reading)



Monthly data, date for LOG 1 (last monthly reading)

**6.9.2 Display structure**

Below diagram shows the display structure with up to 20 primary readings and a number of secondary readings under most primary readings. The number of secondary readings for yearly data and monthly data has been laid down under the DDD code. If nothing is informed in connection with placing the order, the reading is set at 2 yearly data and 12 monthly data. The target date is set at the standard valid for the country code used.

As the display is configured according to the needs of the customer (by selecting DDD code), the display will usually contain fewer readings than shown below.

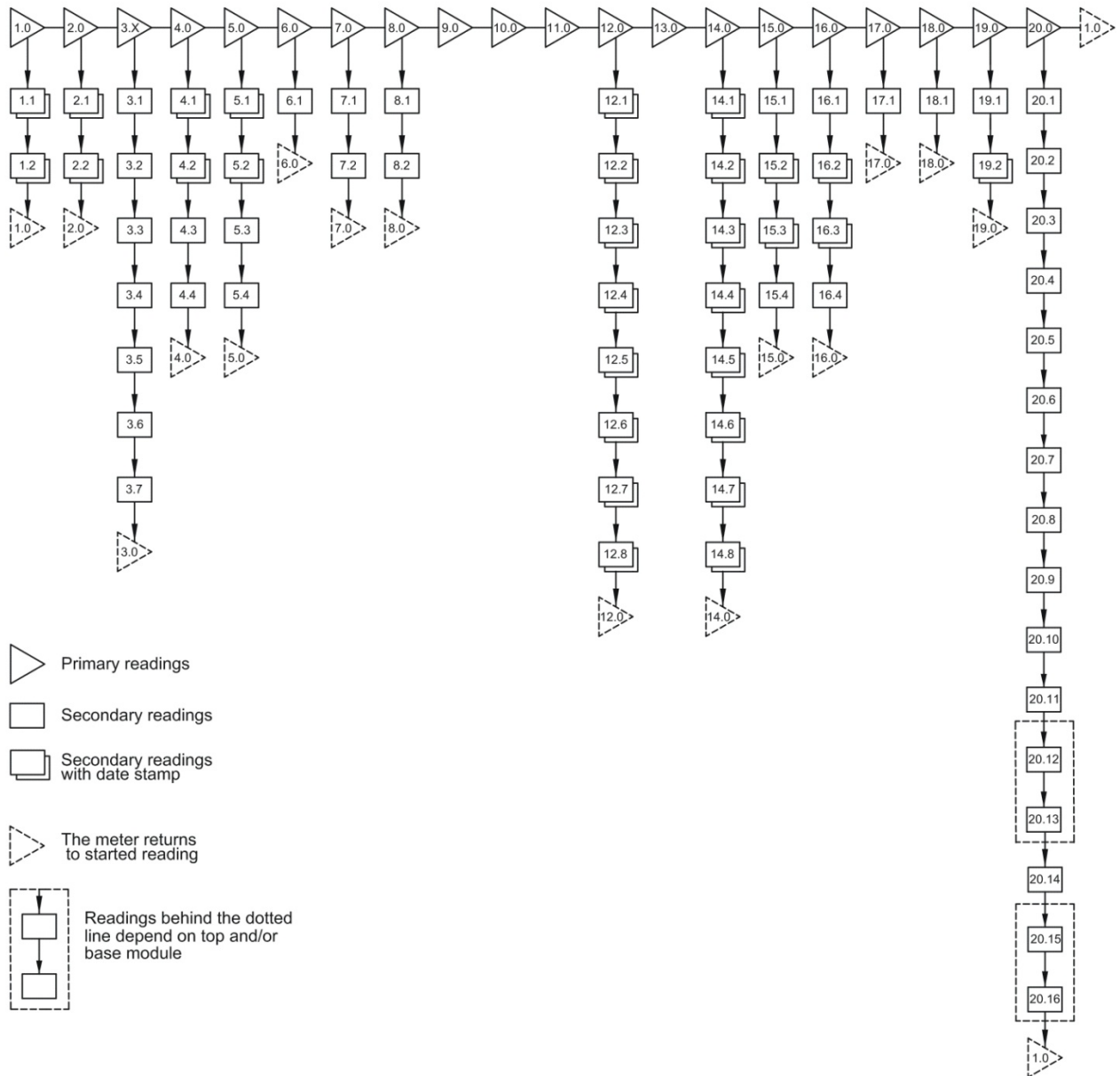



Figure 2

6.9.3 Display grouping

SVM S6 can be configured for a number of various applications, which creates the need for various display groupings. In the overview below the possible readings [•] will appear for heat meter, cooling meter etc., which readings are supported by date stamps, and which reading is automatically shown 4 min. after last activation of the push buttons [1•]. (This chapter applies to design of DDD-codes only).

						Date stamp	Heat meter DDD=2xx	Cooling meter DDD=5xx	Heat/cooling DDD=6xx
1.0	Heat energy (E1)						1•		1•
		1.1	Yearly data	•	•				•
		1.2	Monthly data	•	•				•
2.0	Cooling energy (E3)							1•	•
		2.1	Yearly data	•				•	•
		2.2	Monthly data	•				•	•
3.X	Other energy types								
		3.1	E2						
		3.2	E4						
		3.3	E5						
		3.4	E6						
		3.5	E7						
		3.6	E8 (m <sup>3</sup> *tf)		•				
		3.7	E9 (m <sup>3</sup> *tr)		•				
4.0	Volume V1						•	•	•
		4.1	Yearly data	•	•		•	•	•
		4.2	Monthly data	•	•		•	•	•
		4.3	Mass 1				•	•	•
		4.4	P1				•	•	•
		4.5	Meter factor for V1 (iL or Li) (N° 90)				•	•	•
		4.6	Nominal flow qp (N° 92)				•	•	•
5.0	Volume V2								
		5.1	Yearly data	•					
		5.2	Monthly data	•					
		5.3	Mass 2						
		5.4	P2						
		5.5	Meter factor for V2 (iL or Li) (N° 91)				•	•	•
		5.6	Nominal flow qp (N° 93)				•	•	•
6.0	Hour counter								
		6.1	Error hour counter (N° 60)				•	•	•
7.0	T1 (Flow)						•	•	•
		7.1	Year-to-date average				•	•	•
		7.2	Month-to-date average				•	•	•
8.0	T2 (Return flow)						•	•	•
		8.1	Year-to-date average				•	•	•
		8.2	Month-to-date average				•	•	•
9.0	T1-T2 (Δt) - = cooling						•	•	•
10.0	T3						•	•	•
11.0	T4 (programmed)								
12.0	Flow (V1)						•	•	•
		12.1	Max. this year	•	•		•	•	•
		12.2	Max. yearly data	•	•		•	•	•
		12.3	Min. this year	•	•		•	•	•
		12.4	Min. yearly data	•	•		•	•	•
		12.5	Max. this month	•	•		•	•	•
		12.6	Max. monthly data	•	•		•	•	•
		12.7	Min. this month	•	•		•	•	•
		12.8	Min. monthly data	•	•		•	•	•
13.0	Flow (V2)						•		
14.0	Power (V1)						•	•	•
		14.1	Max. this year	•	•		•	•	•
		14.2	Max. yearly data	•	•		•	•	•
		14.3	Min. this year	•	•		•	•	•
		14.4	Min. yearly data	•	•		•	•	•
		14.5	Max. this month	•	•		•	•	•
		14.6	Max. monthly data	•	•		•	•	•
		14.7	Min. this month	•	•		•	•	•
		14.8	Min. monthly data	•	•		•	•	•

				Date stamp	Heat meter DDD=2xx	Cooling meter DDD=5xx	Heat/cooling DDD=6xx
15.0	VA (Input A)				•	•	•
		15.1	Meter no. VA		•	•	•
		15.2	Yearly data	•	•	•	•
		15.3	Monthly data	•	•	•	•
		15.4	L/imp for VA (N° 65)		•	•	•
16.0	VB (Input B)				•	•	•
		16.1	Meter no. VB		•	•	•
		16.2	Yearly data	•	•	•	•
		16.3	Monthly data	•	•	•	•
		16.4	L/imp for VB (N° 67)		•	•	•
17.0	TA2				•	•	•
		17.1	TL2		•	•	•
18.0	TA3				•	•	•
		18.1	TL3		•	•	•
19.0	Info code				•	•	•
		19.1	Info event counter		•	•	•
		19.2	Info logger (last 36 events)	•	•	•	•
20.0	Customer number (N° 1+2)				•	•	•
		20.1	Date		•	•	•
		20.2	Time		•	•	•
		20.3	Target date		•	•	•
		20.4	Serial no. (N° 3)		•	•	•
		20.5	Prog. (A-B-CCC-CCC) (N° 4)		•	•	•
		20.6	Config 1 (DDD-EE) (N° 5)		•	•	•
		20.7	Config 2 (FF-GG-M-N-T) (N° 6)		•	•	•
		20.8	Software edition (N° 10)		•	•	•
		20.9	Software check-sum (N° 11)		•	•	•
		20.10	Segment test		•	•	•
		20.11	Top module type (N° 20)		•	•	•
		20.12	Top module primary adr. (N° 21)		•	•	•
		20.13	Top module second. adr. (N° 22)		•	•	•
		20.14	Base module type (N° 30)		•	•	•
		20.15	Base module primary adr. (N° 31)		•	•	•
		20.16	Base module second. adr. (N° 32)		•	•	•



Display example showing the PROG number.

A complete survey of existing display codes (DDD) appears from a separate document. Please contact Kamstrup for further details.

### 6.10 Real Time Clock (RTC)

SVM S6 has built-in real time clock and battery backup. This is valuable for applications where correct date/time in data loggers as well as time-controlled tariffs are important. The battery will ensure the RTC function for at least 3 years without power during the entire lifetime of SVM S6. This small battery will only back-up the RTC, meaning that the display will go blank, when the main supply or main battery is off.

If a top module with RTC is mounted, the top module's RTC will not have any effect on the meter's own RTC.

### 6.11 Info codes

SVM S6 constantly surveys a number of important functions. Where serious errors have occurred in the measuring system or in the installation, a flashing "INFO" will appear in the display while the error exists. The "INFO" panel will flash for as long as the error exists no matter which reading is selected. The " INFO " panel will automatically turn off, when the source of error has been corrected.

#### 6.11.1 Examples of info codes on the display

Ex. 1



#### Flashing "INFO"

If the info code exceeds 0 a flashing " INFO " will appear in the information panel.

Ex. 2

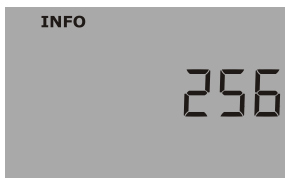

#### Current info code

When the upper (primary) push button is activated several times the current info code can be shown on the display.

Ex. 3

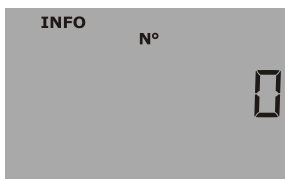

#### Info event counter

- indicates how many times the info code has been changed.

Ex. 4

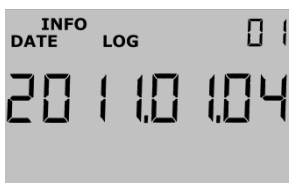

#### Info logger

By pressing the lower push button once more the data logger for the info code is displayed.

First, the date of the first change is displayed ...



...then the info code appearing on that particular date is displayed. In this case there has been a "bursting alarm" on 4<sup>th</sup> January 2011.

The data logger stores the last 50 changes, of which the last 36 changes are shown in the display. All 50 changes can be read by means of LogView/MT Pro.

Time, E1 (heat energy) and E3 (Cooling energy – if available) will be logged when the info code is changed. Naturally, the info code will still be logged during changed info codes. To read out Time and E1 together with the info code it is necessary to use LogView.

In addition, the info code is stored in the hourly logger, the daily logger, the monthly logger and the yearly logger for diagnostic purposes.

6.11.2 Types of info codes

Info code	Description	Response time
0	No irregularities	-
1	Supply voltage has been cut off	-
8	Temperature sensor T1 outside measuring range	1...10 min.
4	Temperature sensor T2 outside measuring range	1...10 min.
32	Temperature sensor T3 outside measuring range	1...10 min.
64	Leak in the cold-water system	1 day
256	Leak in the heating system	1 day
512	Burst in the heating system	120 sec.
<b>ULTRAFLOW® X4 info (if activated CCC=4XX)</b>		
16	Flow sensor V1, Datacomm error	After 1 day (00:00)
1024	Flow sensor V2, Datacomm error	After 1 day (00:00)
2048	Flow sensor V1, Wrong meter factor	After 1 day (00:00)
128	Flow sensor V2, Wrong meter factor	After 1 day (00:00)
4096	Flow sensor V1, Signal too low (Air)	After 1 day (00:00)
8192	Flow sensor V2, Signal too low (Air)	After 1 day (00:00)
16384	Flow sensor V1, Wrong flow direction	After 1 day (00:00)
32768	Flow sensor V2, Wrong flow direction	After 1 day (00:00)

Info code 1 will be logged when the mains supply/main battery is switched OFF and Info code 1 will be deleted when the mains supply/main battery is switched ON. Thereby the time without power can be retrieved from the logger data.

If several info codes appear at the same time the sum of the info codes is shown. E.g. if both temperature sensors are outside measuring range, info code 12 will appear.

During configuration at the factory the individual info - active or passive - are set and in this way a standard heat meter not using T3, cannot display info code 32.

Info = 16-1024-2048-128-4096-8192-16384-32768 functions via data communication between SVM S6 and ULTRAFLOW® 54. See paragraph 13.2.4, Info code setup, in order to change the settings.

6.11.3 Transport mode

When the meter leaves the factory it is in transport mode, and the info codes are only active on the display and not in the data logger. This prevents both "info event" to increment and the storage of non relevant data in the info logger. When the meter has summed up the volume register for the first time after installation the info code is automatically set at active.

6.11.4 Info event counter

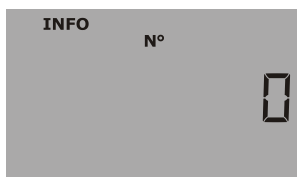

Info event counter

Counting takes place every time the info code is changed.

The info event counter will be 0 on receipt, as "transport mode" prevents counting during transport

Info code	"INFO" on display	Registration in the info, daily, monthly or yearly logger	Counting of info events
1	No	Yes	At each "Power-On-Reset"
4, 8, 32	Yes	Yes	When info 4, 8, 32 are set or removed. Max. 1 per measurement of temperature
64, 256	Yes	Yes	When info is set and when info is deleted. Max. 1 time/day
512	Yes	Yes	When info is set and when info is deleted. Max. 1 time/120 sec.
16, 1024, 2048, 4096, 8192, 16384, 32768	Yes	Yes	When info is set and when info is deleted. Max. 1 time/day

6.11.5 Error hour counter

An error hour counter is added. This will sum up the approx. number of hours with info code > zero.

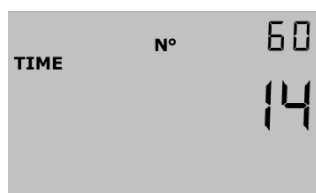

### 6.12 Tariff functions

SVM S6 has 2 extra registers TA2 and TA3 to accumulate heat energy or cooling energy (EE=20 accumulates volume) in parallel to the main register based on a programmed tariff condition. No matter which tariff form is selected the tariff registers are indicated as TA2 and TA3 in the display.

The main register is always accumulated as it is considered a legal billing register, irrespective of the selected tariff function. The tariff conditions TL2 and TL3 are monitored before each integration. When the tariff conditions are fulfilled the consumed heat energy is counted in either TA2 or TA3, in parallel to the main register.

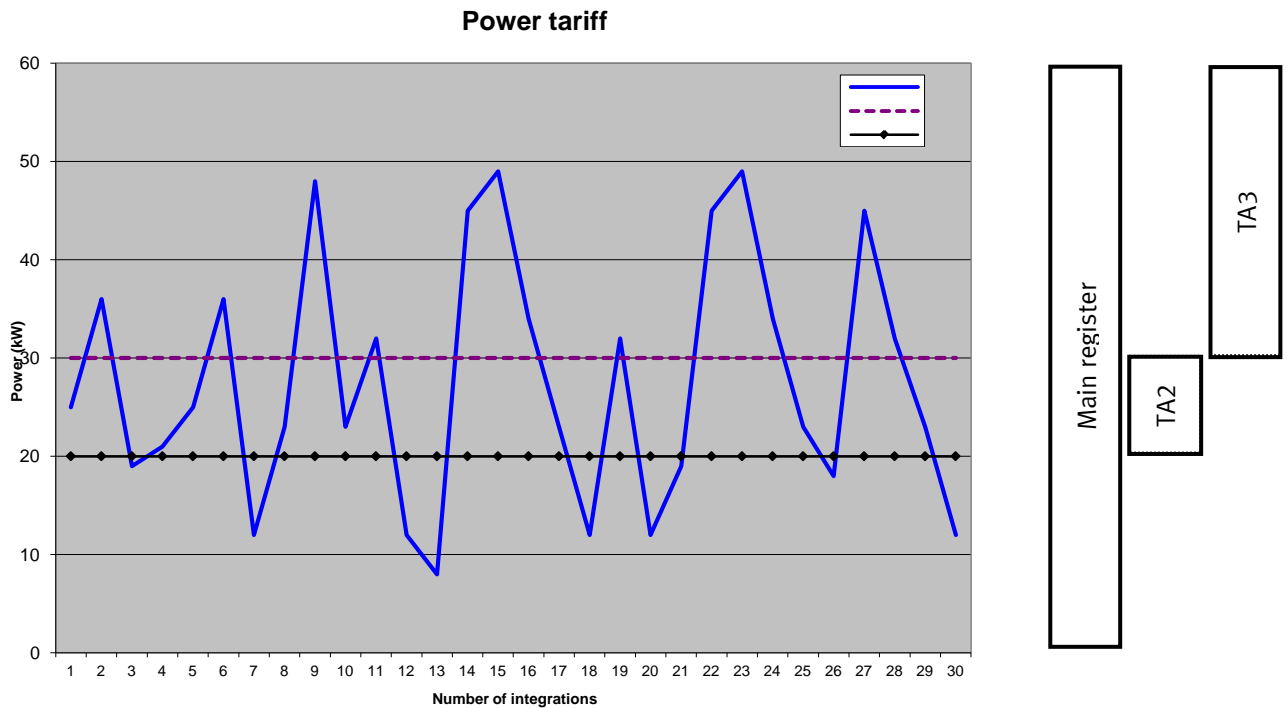

To each tariff function two tariff conditions, TL 2 and TL3 are connected, which are always used in the same tariff type. Therefore, it is not possible to "mix" two tariff types.

Example: EE=11 (Power tariff)

TA2 shows the consumed energy...

...over the power limit TL2 (but under TL3)



**6.12.1 Tariff types**

Below table indicates which tariff types SVM S6 can be configured to:

EE=	TARIFF TYPE	FUNCTION	Country code 2xx	Country code 5xx	Country code 6xx
00	No tariff active	No function			
11	Power tariff	Energy is accumulated in TA2 and TA3 based on the power limits in TL2 and TL3	•	•	
12	Flow tariff	Energy is accumulated in TA2 and TA3 based on the flow limits in TL2 and TL3	•	•	
13	Cooling tariff	Energy is accumulated in TA2 and TA3 based on the Δt limits in TL2 and TL3	•	•	
14	Flow temperature tariff	Energy is accumulated in TA2 and TA3 based on the tF-limits in TL2 and TL3	•	•	
15	Return flow temperature tariff	Energy is accumulated in TA2 and TA3 based on the tR-limits in TL2 and TL3	•	•	
19	Time-controlled tariff	TL2=Starting time for TA2 TL3=Starting time for TA3	•	•	
20	Heat/cooling volume tariff (TL2 and TL3 are not used)	Volume (V1) is split up into TA2 for heat (T1>T2) and TA3 for cooling (T1<T2) (Recommended on Heating/Cooling applications)			•
21	PQ tariff	Energy at P>TL2 is stored in TA2 and energy at Q>TL3 is stored in TA3	•	•	

Please note that only tariff No. 20 can be used in a combined heat / cooling meter. All other tariffs can only be used with either a heat meter or a cooling meter. The meter cannot distinguish heat energy (E1) from cooling energy (E3) and vice versa.

**EE=00 No tariff active**

If the tariff function should not be used, select the set-up for EE=00.

However, the tariff function can be made active at a later date by a reconfiguring the function by means of METERTOOL for SVM S6.

**EE=11 Power controlled tariff**

When the current power is higher than TL2, but lower than/equal to TL3, the energy is counted in TA2 in parallel to the main register. If the current power exceeds TL3, the energy is counted in TA3 in parallel to the main register.

$P \leq TL2$	Counting in main register only	$TL3 > TL2$
$TL3 \geq P > TL2$	Counting in TA2 and the main register	
$P > TL3$	Counting in TA3 and the main register	

When setting up data TL3 must always be higher than TL2. Among other things the power controlled tariff is used as a basis for calculating the individual consumer's connection costs. Furthermore, this tariff form can provide valuable statistical data when the energy supplier evaluates new installation activities.

**EE=12 Flow controlled tariff**

When the current water flow is higher than TL2 but lower than/equal to TL3, the energy is counted in TA2 in parallel to the main register. If the current water flow becomes higher than TL3, the energy is counted in TA3 in parallel to the main register. When setting up data, TL3 must always be higher than TL2.

$q \leq TL2$	Counting in main register only	$TL3 > TL2$
$TL3 \geq q > TL2$	Counting in TA2 and the main register	
$q > TL3$	Counting in TA3 and the main register	

Among other things the flow controlled tariff is used as a basis for calculating the individual consumer’s connection costs. Furthermore, this tariff form provides valuable statistical data when the energy supplier evaluates new installation activities.

When the power or flow tariff is used it is possible to get a total overview of the total consumption compared to the part of the consumption, that is used above the tariff limits.

**EE=13 Differential temperature tariff ( $\Delta t$ )**

When the current T1-T2 ( $\Delta t$ ) is lower than TL2, but higher than TL3, the energy is counted in TA2 in parallel to the main register. If the current cooling drops to less than/equal to TL3, the energy is counted in TA3 in parallel to the main register.

$\Delta t \geq TL2$	Counting in main register only	$TL3 < TL2$
$TL3 < \Delta t < TL2$	Counting in TA2 and the main register	
$\Delta t \leq TL3$	Counting in TA3 and the main register	

When setting up tariff limits TL3 must always be lower than TL2.

The T1-T2 tariff can be used to form the basis for a weighted user payment. Low  $\Delta t$  (small difference between flow and return flow temperatures) is uneconomical for e.g. the heat supplier.

**EE=14 Flow temperature tariff**

When the current flow temperature (T1) is higher than TL2, but lower than/equal to TL3, the energy is counted in TA2 in parallel to the main register. If the current flow temperature becomes higher than TL3, the energy is counted in TA3 in parallel to the main register.

$T1 \leq TL2$	Counting in main register only	$TL3 > TL2$
$TL3 \geq T1 > TL2$	Counting in TA2 and the main register	
$T1 > TL3$	Counting in TA3 and the main register	

When setting up data TL3 must always be higher than TL2.

The flow temperature tariff can form the basis of billing of those customers who are guaranteed a given flow temperature. When the “guaranteed” minimum temperature set at TL3, the calculated consumption is accumulated in TA3.

**EE=15 Return temperature tariff**

When the current return temperature (T2) is higher than TL2 but lower than/equal to TL3, the energy is counted in TA2 in parallel to the main register. If the current return temperature becomes higher than TL3, the energy is counted in TA3 in parallel to the main register.

$T2 \leq TL2$	Counting in main register only	$TL3 > TL2$
$TL3 \geq T2 > TL2$	Counting in TA2 and the main register	
$T2 > TL3$	Counting in TA3 and the main register	

When setting up data TL3 must always be higher than TL2.

The return temperature tariff can form the basis of a weighted user payment. A high return flow temperature indicates insufficient heat utilization which is uneconomical for e.g. the heat supplier.

**EE=19 Time-controlled tariff**

The time-controlled tariff is used for time division of the heat consumption. If TL2 = 08:00 and TL3 = 16:00 the consumption of the entire day from 08:00 till 16:00 will be accumulated in TA2, whereas the consumption of the evening and the night from 16:01 till 07:59 will be accumulated in TA3.

TL2 must have a lower number of hours than TL3.

$TL3 \geq \text{Clock} \geq TL2$	Counting in TA2 and the main register	$TL3 > TL2$
$TL2 > \text{Clock} > TL3$	Counting in TA3 and the main register	

Among other things the time tariff is suitable for billing in housing sectors close to industrial sectors with a large consumption of district heating and for billing industrial customers.

**EE=20 Heat/cooling volume tariff**

The heat/cooling volume tariff is used for dividing volume into heat and cooling consumption. TA2 accumulates the volume consumed together with E1 (heat energy) and TA3 accumulates the volume consumed together with E3 (cooling energy).

$T1 \geq T2$	Volume is accumulated in TA2 and V1	TL2 and TL3 are not used
$T2 > T1$	Volume is accumulated in TA3 and V1	

In connection with combined heat/cooling measurement the total volume in the V1 register is accumulated, whereas the heat energy is accumulated in E1 and the cooling energy in E3. The heat/cooling tariff divides the consumed volume into heating and cooling volume.

EE=20 should always be selected together with combined heat/cooling meters, type 602-xxxxxxx-6xx.

**EE=21 PQ tariff**

The PQ tariff is a combined power and flow tariff. TA2 functions as a power tariff and TA3 as a flow tariff.

$P \leq TL2$ and $q \leq TL3$	Counting in the main register only	TL2 = power limit (P) TL3 = flow limit (q)
$P > TL2$	Counting in TA2 and the main register	
$q > TL3$	Counting in TA3 and the main register	
$P > TL2$ and $q > TL3$	Counting in TA2, TA3 and the main register	

Among other things the PQ tariff is used for customers paying a fixed duty based on max. power and max. flow.

### 6.13 Data loggers

SVM S6 contains a permanent memory (EEPROM), where the results of a number of various data loggers are stored. The meter contains following data loggers:

Data logging interval	Data logging depth	Logged value	Logger read-out
Yearly logger	15 years	Counter registers	LogView/MT Pro •
Monthly logger	36 months	Counter registers	LogView/MT Pro •
Daily logger	460 days	Consumption (increase)/day	LogView/MT Pro ♦
Hourly logger	1392 hours	Consumption (increase)/hour	LogView/MT Pro ♦
Programmable data logger top module 67-0B and base module 67-00-22	1080 loggings Logging interval 1-1440 min. (e.g. 45 days' hour loggings or 11 days' 15 min. loggings)	30 registers and values	AMR *), LogView/MT Pro •
Info logger	50 events (36 events can be displayed)	Info code, date, time and energy (E1/E2) **)	LogView/MT Pro

\*) Example of AMR (Automatic Meter Reading) for the data logger is GSM/GPRS. See chapter 13.4 about LogView.

\*\*\*) Only info code and date appear from the display.

The loggers are static and therefore the register types cannot be changed, furthermore, the logging intervals are fixed. When the last record has been written in the EEPROM the oldest one is overwritten.

#### 6.13.1 Yearly, monthly, daily and hourly loggers

Following registers are logged every year and every month on target date as counter values. In addition, the increases of the day and the hour are logged at midnight.

Register type	Description	Yearly logger	Monthly logger	Daily logger	Hourly logger	67-0B 67-00-22 Prog. logger
Date (YY.MM.DD)	Year, month and day for logging times	•	•	♦	♦	•
Clock (hh.mm.ss.)	Time	-	-	-	-	•
Log Info	Status, quality stamping of log record	-	-	-	-	•
E1	E1=V1(T1-T2)k Heat energy	•	•	♦	♦	•
E2	E2=V2(T1-T2)k Heat energy	•	•	♦	♦	•
E3	E3=V1(T2-T1)k Cooling energy	•	•	♦	♦	•
E4	E4=V1(T1-T3)k Flow energy	•	•	♦	♦	•
E5	E5=V2(T2-T3)k Return flow energy or tap from return flow	•	•	♦	♦	•
E6	E6=V2(T3-T4)k Tap water energy, separate	•	•	♦	♦	•
E7	E7=V2(T1-T3)k Tap water energy from flow	•	•	♦	♦	•
E8	E8=m <sup>3</sup> x T1 (flow)	•	•	♦	-	•
E9	E9=m <sup>3</sup> x T2 (return flow)	•	•	♦	-	•
TA2	Tariff register 2	•	•	-	-	-
TA3	Tariff register 3	•	•	-	-	-
V1	Volume register for Volume 1	•	•	♦	♦	•
V2	Volume register for Volume 2	•	•	♦	♦	•
VA	Extra water or electricity meter connected to Input A	•	•	♦	♦	•
VB	Extra water or electricity meter connected to Input B	•	•	♦	♦	•
M1	Mass corrected V1	-	-	♦	♦	•
M2	Mass corrected V2	-	-	♦	♦	•
INFO	Information code	•	•	♦	♦	•
DATE FOR MAX. FLOW V1	Date stamp for max. flow in the period	•	•	-	-	-
MAX. FLOW V1	Value for max. flow in the period	•	•	-	-	-
DATE FOR MIN. FLOW V1	Date stamp for min. flow in the period	•	•	-	-	-
MIN. FLOW V1	Value for min. flow in the period	•	•	-	-	-
DATE FOR MAX. POWER V1	Date stamp for max. power in the period	•	•	-	-	-

MAX. POWER V1	Value for max. power in the period	•	•	-	-	-
DATE FOR MIN. POWER V1	Date stamp for min. power in the period	•	•	-	-	-
MIN. POWER V1	Value for min. power in the period	•	•	-	-	-
T1avg	Time based average for T1	-	-	◆	◆	-
T2avg	Time based average for T2	-	-	◆	◆	-
T3avg	Time based average for T3	-	-	◆	◆	-
P1avg	Time based average for P1	-	-	◆	◆	-
P2avg	Time based average for P2	-	-	◆	◆	-
Operating hour counter	Accumulated number of operating hours	•	•	-	-	•
T1	Current value of T1	-	-	-	-	•
T2	Current value of T2	-	-	-	-	•
T3	Current value of T3	-	-	-	-	•
T4	Current value of T4	-	-	-	-	•
T1-T2 (Δt)	Current differential value	-	-	-	-	•
Flow (V1)	Current water flow of V1	-	-	-	-	•
Flow (V2)	Current water flow of V2	-	-	-	-	•
Power (V1)	Actual power	-	-	-	-	•
P1	Current pressure of flow	-	-	-	-	•
P2	Current pressure of return	-	-	-	-	•

**Note:** Continuous maximum water flow and permanent  $\Delta\Theta > 75$  K may cause overflow in the daily data logger at CCC=010-011-012-013-150-202-205. With these combinations we recommend you to use Prog. data logger type 67-0B or type 67-00-22.

**6.13.2 Info logger**

Every time the information code is changed, date and info code are logged. Thereby, it is possible to data read the last 50 changes in the information code and the date of the change.

Register type	Description
Date (YY.MM.DD)	Year, month and day for the logging time
Info	Information code on above date
E1	Heat energy
E3	Cooling energy
Clock (hh.mm.ss.)	Time

When the info logger is read on the display the last 36 changes including dates can be read. Heat energy, cooling Energy, and time can be read out via LogView only. Please see 6.11 for more information.

### 6.14 Leak surveillance

#### 6.14.1 District heating installations

The leak surveillance system is primarily intended for directly connected district heating installations, i.e. installations without heat exchanger between the district heating network and the heating system of the housing. The surveillance system consists of two water meters based on the ultrasonic principle placed in both flow and return pipe, and of temperature sensors in both pipes. In addition, the electronic unit SVM S6, which in addition to calculating the heat energy also surveys the mass difference (temperature compensated volume) that may appear between flow and return pipe.

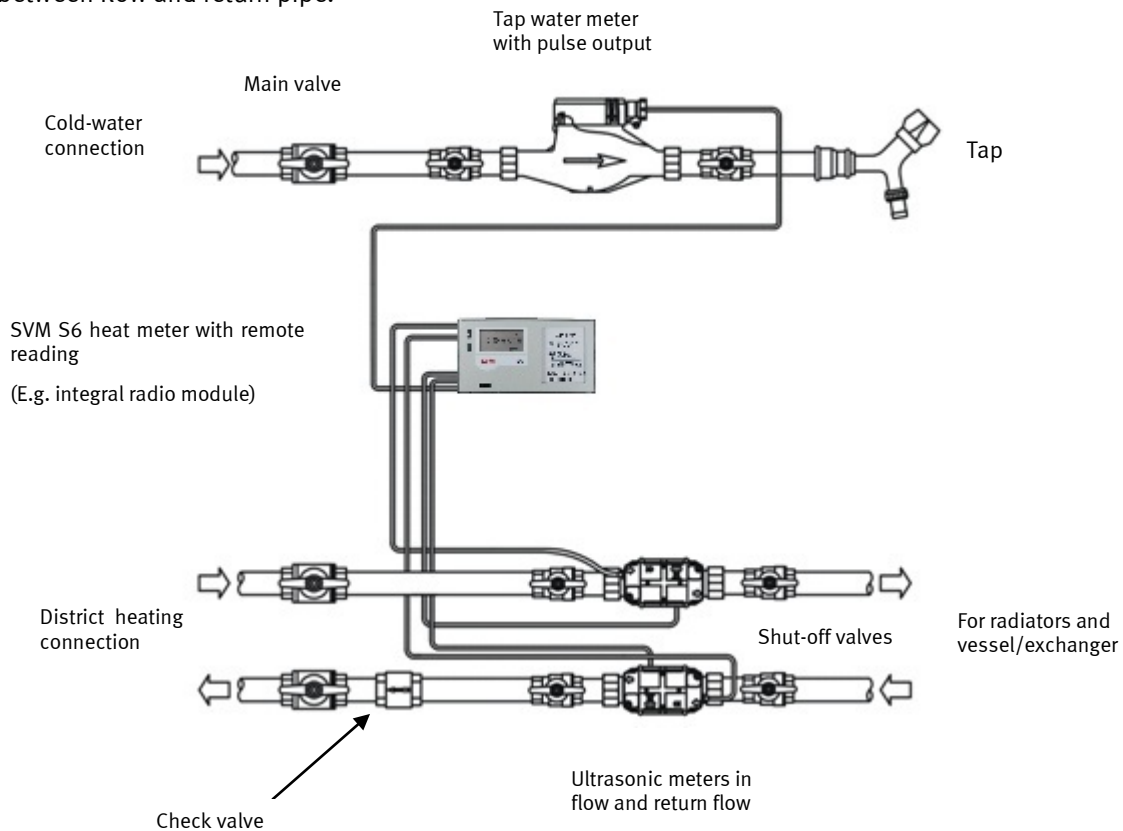

If a difference of more than 20% of the measuring range (corresponding to 300 l/h in a single-family house) is registered, an alarm will be sent within 120 sec. via remote communication.

Small leaks from 15 kg/h and upwards for qp 1.5 m<sup>3</sup>/h are under surveillance on the basis of a 24-hour average to rule out incorrect alarms as a consequence of air pockets and fast flow changes e.g. from hot-water exchangers.

District heating leak surveillance (V1-V2)	
M=	Sensitivity in leak surveillance
0	OFF
1	1.0% qp + 20% q
<b>2</b>	<b>1.0% qp + 10% q</b>
3	0.5% qp + 20% q
4	0.5% qp + 10% q

**NB:** M=2 is a default value when leak surveillance is used. Higher degrees of sensitivity, e.g. M=4 is only possible by means of METERTOOL. Please see 3.8.1 for an example of how the sensitivity is calculated.

Info codes for leak/bursting are only active when M > 0 or N > 0, respectively.

Example: The curve below illustrates the difference between Mass V1 and Mass V2 in an extract of 60 days before the leak in a floor heating pipe was the reason for a leak alarm. As will appear from below, there is a fluctuation of approx.  $\pm 1$  kg/hour in the first 43 days which is a normal fluctuation for installations without leaks.

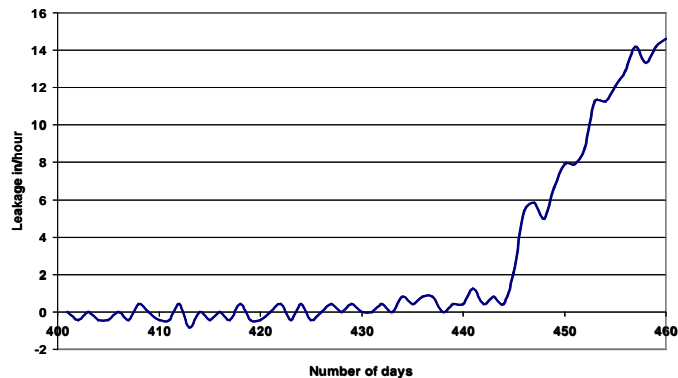

**6.14.2 District heating bursting**

Every 30 sec. the current flow in the flow pipe is compared with that in the return flow pipe. If the difference at 4 measurings in a row (120 sec.) is larger than 20% of the nominal flow info = 00512 and a "bursting alarm" will be sent via remote communication.

**6.14.3 Cold-water systems**

In addition to above functions SVM S6 can be connected to the pulse signal from the cold-water meter of the house. In this way it can survey the cold-water consumption. A flushing toilet cistern, leaky heating coils in the water tanks or other leaks will cause that impulses from the cold-water meter are received 24 hours a day.

If SVM S6 does not register e.g. at least one continuous hour/day without pulses from the water meter, this is a sign of a leak in the water system and an alarm will be sent via remote communication.

Cold-water leak search (VA)	
N=	Constant leak at no consumption (pulse resolution 10 l/pulse)
0	OFF
1	20 l/h (1/2 hour without pulses)
2	10 l/h (1 hour without pulses)
3	5 l/h (2 hours without pulses)

NB: N=2 is a default value in connection with leak surveillance. Higher degree of sensitivity, e.g. N=3 is only possible if using METERTOOL. Infocodes for leak/bursting are only active when M > 0 or N > 0, respectively.

**6.14.4 Receiving alarm messages**

When the meter has registered a leak or bursting it will send an alarm message to a receiving station, where incoming alarms are handled on the basis of an encoded action pattern that is laid down for each individual customer, e.g. starting with an SMS message to the customer's mobile phone. At the same time the utility on duty receives the message. Regular data readings from SVM S6 to the receiving station/monitoring center ensure that defective remote readings, if any, are detected.

**6.14.5 Surveillance, but no automatic blocking**

The leak surveillance system is based on installation at a large number of private district heating customers'. Usually, the individual utility installs and maintains the leak surveillance, integrated with the compulsory heat metering at all district heating customers in their area. In this way, the individual private district heating customers neither maintain the system nor perform other technical tasks in connection with the installed leak surveillance system, and the surveillance system must not imply an increased risk of faulty blocking that may lead to frost bursts. As a consequence of this the entire system must have a reliability that ensures operation for 12 years without maintenance. As neither thermally nor electrically activated shut-off valves can be expected to have such a long lifetime it will not be possible to use automatic blocking.

**6.14.6 First day after reset**

The first day after installation (when the meter has had no supply voltage) no infocodes will be set and no alarms will be sent in case of calculated district heating or cold-water leak.

This limitation has been introduced to avoid wrong alarms as a result of the installation and the shortened metering period.

The alarm function can be tested via remote communication by pressing both push buttons simultaneously, until a "Call" appears in the display.



## 6.15 Reset functions

### 6.15.1 Resetting the hour counter

As the hour counter usually is used to control that the meter has been in operation in the entire billing period (e.g. 1 year = 8760 hours) the district heating supplier must always be informed which meters have had their hour counter reset.

The operational hour counter can only be reset via the front buttons. Please see 6.18.



### 6.15.2 Resetting data loggers

Separate reset of data loggers, info loggers, max. & min. loggers (without resetting the legal registers) are only possible by means of METERTOOL. See paragraph 13 for further details.

### 6.15.3 Resetting all registers

Resetting all legal and non-legal registers including all data loggers, info loggers, max. & min. loggers can only be made by using METERTOOL, if the verification seal is broken and the internal "Total programming lock" is short-circuited. As the verification seal is broken, this can only be made at an accredited laboratory.

Following registers are reset:

All legal and non-legal registers including all data loggers, info loggers, max. & min. loggers (max. values are set at zero, whereas min. values are set at 100000).

After reset "Date" is set at 2000.01.01 and is then changed to current date/time of the PC used for the task. Remember to check correct date/time (technical standard time = "winter-time") on the PC before the reset function is initiated.

## 6.16 SMS Commands

SVM S6 can be read by means of an SMS. In order to do so, a GSM-module (68G6xxxx) fitted with a SIM-card must be connected to the meter. To read the meter you send an SMS from a mobile phone direct to the meter. Subsequently, you receive a reply with the following values:

- Acc. energy: [kWh], [MWh], [GJ] or [Gcal]
- Current power: [kW] or [MW]
- Hour counter
- Meter number

It is also possible to read the modem's signal strength by means of an SMS. You receive a reply with the modem's current signal strength on a scale of 0 to 31, the best value being 31. The signal strength must be minimum 12. See the examples on the next page.

NOTE: SMS commands must be written in **either** capital letters **or** small letters, i.e. an SMS command must not include a mixture of capital and small letters

<b>READ_HEAT_METER – for reading a SVM S6</b>	
Syntax	<b>=READ_HEAT_METER#</b>
Return reply, error	<b>NO ANSWER</b>
Example of SMS command	<b>=READ_HEAT_METER#</b>
Example of correct reply	<b>12.067Gj, 120.0kW 6930 Hours, Meter No.: 6055524</b>

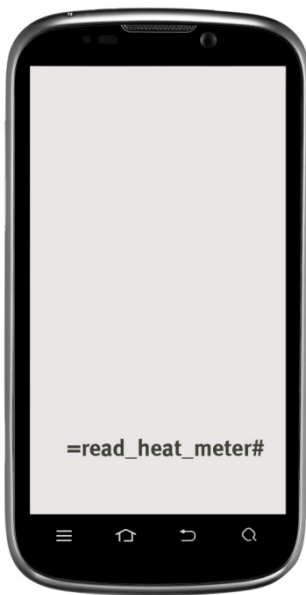

<b>SIGNAL – for reading the signal strength</b>	
Syntax, command	<b>=SIGNAL#</b>
Return reply, error	<b>NO ANSWER</b>
Example of SMS command	<b>=SIGNAL#</b>
Example of correct reply	<b>Signal: 16(0-31)</b>

### 6.17 Set-up via the front keys

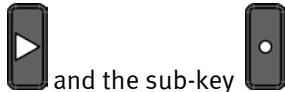

Via the main key  and the sub-key  on SVM S6, a number of settings can be selected.

#### 6.17.1 Activate the setup-menu

The setup-menu is activated in the following way:

- 1) Select the display reading that you wish to change
- 2) Remove the calculator from the base
- 3) Wait until the display goes blank (up to 2.5 minutes). Meanwhile do not touch the front keys
- 4) While replacing the calculator on the base, press and hold the main key
- 5) The setup-menu is now active

Having activated the setup-menu, the register that you wish to change is now displayed with the rightmost digit flashing (in the below example the “Date” has been selected):



If a display register that is not supported by the front key set-up is selected, the meter will show the normal display without activating the setup-menu.

#### 6.17.2 Setup of a display register

When the setup-menu is activated, the actual value in the register selected will be displayed (in the below example the date 2011.07.14)

The value of the flashing digit can be increased by pressing the sub-key:

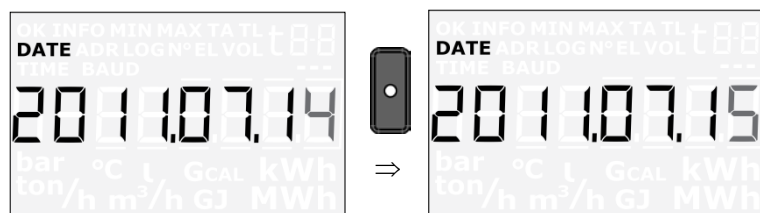

When pressing the main key, the next digit to the left will be flashing:

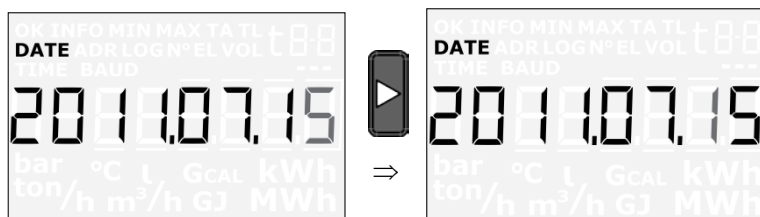

### 6.17.3 Exit setup-menu

When the display value has been changed as required, hold the main key for 10 seconds, until the "OK" segment is displayed. The display reverts to legal reading.

The new value is checked. If it is valid, the new value is saved. If it is invalid, the old value is kept and the "OK" segment will not be displayed within approx. 3 seconds. The display reverts to legal reading.

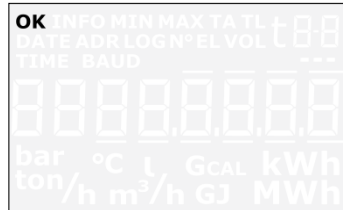

If you wish to exit the setup-menu without saving the new value:

- 1) Remove the calculator from the base
- 2) Wait until the display goes blank (up to 2.5 minutes). Meanwhile do not touch the front keys
- 3) Replace the calculator on the base without pressing the front keys

Allow some seconds for the meter to boot-up without pressing the front keys. The normal display register is now shown and the setup menu is deactivated.

Note that if the front keys are not activated for 4 minutes in the setup-menu, the setup-menu will be deactivated and the meter will automatically return to normal operation.

No data will be stored in the meter's memory, unless the "OK" segment is displayed.

### 6.17.4 Display registers supported by the setup-menu

The following registers are supported by the setup-menu:

- Date
- Clock
- Primary M-Bus address (for both top and base module if mounted)
- Preset of Input A
- Preset of Input B
- Meter No. for Input A
- Meter No. for input B
- Pulse value for Input A
- Pulse value for Input B

## 6.18 Reset via the front keys

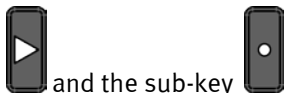

Via the the main key and the sub-key on SVM S6, a number of reset functions can be made.

### 6.18.1 Activate the reset-menu

The reset-menu is activated in the following way:

- 1) Select the display reading that you wish to reset
- 2) Remove the calculator from the base
- 3) Wait until the display goes blank (up to 2.5 minutes). Meanwhile do not touch the front keys
- 4) While replacing the calculator on the base, press and hold the main key
- 5) The reset-menu has now been activated

Having activated the reset menu, either the operation hour counter, the infoevent-counter or the error hour counter will be displayed, depending on the register which was selected before activating the reset menu.

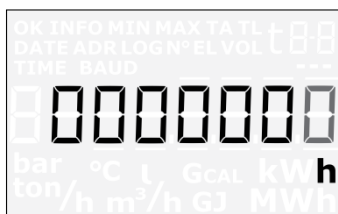

When the reset menu has been activated, "0" will be displayed. It is not possible to change to any other value. It is only possible to "save" the value = 0 in order to reset the register, or to leave the reset menu without reset.

If a display register that is not supported by the reset-menu is selected, the meter will show the normal display without activating the reset menu.

### 6.18.2 Exit the reset menu

When the operation hour counter, the info-event counter or the error hour counter displays "0", hold the main key for 5-6 seconds, until the "OK" segment is displayed, and the display reverts to legal reading.

If you wish to exit the reset menu without resetting any registers:

- 4) Remove the calculator from the base
- 5) Wait until the display goes blank (up to 2.5 minutes). Meanwhile do not touch the front keys
- 6) Replace the calculator on the base without pressing the front keys

Allow some seconds for the meter to boot-up without pressing the front keys. The normal display register is now displayed and the reset menu is deactivated.

Note that if the front keys are not activated for 4 minutes in the setup-menu, the setup-menu will be deactivated and the meter will automatically return to normal operation.

No data will be reset in the meter's memory, unless the "OK" segment is shown.

### 6.18.3 Display registers supported by the reset menu

The following registers are supported by the reset menu:

- Operating hour counter
- Error hour counter
- Info event counter

### 6.19 Preset the pulse value for V1 and V2

It is possible to preset the pulse value for V1 and V2 in SVM S6 by changing the CCC-codes. In order to do so the meter must be connected via an optical eye to a PC with the METERTOOL software running. Break the verification seal and short circuit the TOTAL PROG button on the inside of the calculator top with a short circuit pen.

**Note!** This should only be done by an accredited laboratory, since breaking of the verification seal revokes the legal verification as well as the factory warranty.

After shorting the total programming circuit, the meter is set in programming mode for 4 minutes. Set the pulse value by selecting a suitable CCC-code. As long as METERTOOL is communicating with the meter, the time for programming mode is extended, and after 4 minutes of inactivity the meter will return to normal mode. When the desired pulse values for V1 and V2 are set, METERTOOL can be used to terminate the programming mode by a reset, and the meter returns to normal mode ready for use.

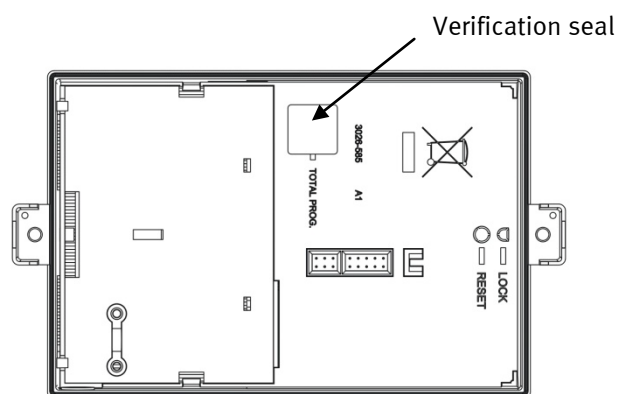

Figure 3

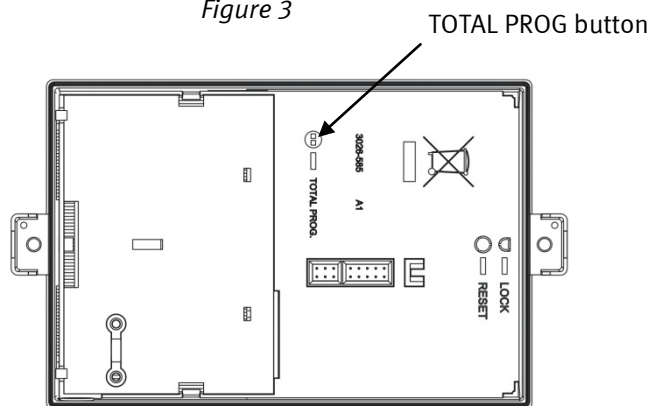

Figure 4

## 7 Flow sensor connection

SVM S6 can be used with up to 4 pulse inputs, of which V1 and V2 are used for energy calculation and leak surveillance, whereas VA and VB are used to accumulate pulses e.g. from tap-water meters and electricity meters.

V1 and V2 can either be used for fast pulses (CCC > 100) or for slow pulses (CCC = OXX). Fast and slow pulses cannot be used simultaneously.

### 7.1 Volume inputs V1 and V2

SVM S6 can be connected to one or two flow sensors depending on the required application. Typical heat installations with one flow sensor are always connected to V1 irrespective if this flow sensor is installed in flow pipe or return pipe.

Almost all available flow sensor types with pulse output can be connected as the standard connection PCB receives pulses from both electronic and mechanical meters. In addition, a connection PCB that receives 24 V active pulses is also available.

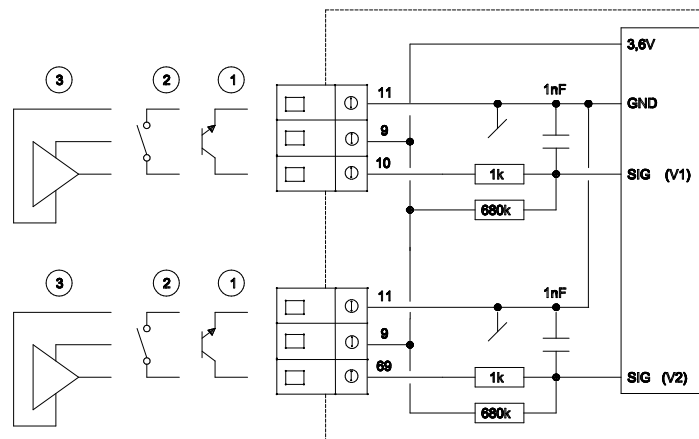

#### 7.1.1 Flow sensor with transistor- or FET output ①

Typically, the signaller is an optocoupler with a transistor or a FET output. V1 is connected to terminal 10(+) and 11(-), V2 is connected to terminals 69(+) and 11(-). Terminal 9 is not used in this application.

The leak current in the transistor or FET output must not exceed 1µA in OFF state and there must be max. 0.4 V in ON state.

A suitable CCC code must be selected with the same number of pulses/liter as the flow part, and for this flow sensor type the CCC code must be CCC > 100.

Example: CCC=147 fits an electronic meter with 1 pulse/liter and qp of 150 m<sup>3</sup>/h.

#### 7.1.2 Flow sensor with Reed switch output ②

The signaller is a Reed switch typically mounted on vane wheel or Woltmann meters, or a relay output from e.g. a magnetic inductive flow sensor. V1 is connected to the terminals 10(+) and 11(-), V2 is connected to the terminals 69(+) and 11(-). Terminal 9 is not used in this application.

The leak current must not exceed 1µA in OFF state and there must be max. 10 kΩ in ON state.

A suitable CCC code must be selected with the same number of pulses/liter as the flow part, and for this flow sensor type the CCC code must be in the range 010 ≤ CCC ≤ 022.

Example: CCC=012 fits a mechanical flow sensor with 100 liter/pulse. Flow sensors with Qmax. in the range 10...300 m<sup>3</sup>/h can use this CCC code.

**7.1.3 Flow sensor with active output supplied from SVM S6** ③

This connection is used both together with Kamstrup’s ULTRAFLOW® and Kamstrup’s electronic pick-up units for vane wheel meters. The power consumption in these units is very low and is adapted to the battery lifetime of SVM S6.

A suitable CCC code must be selected with the same number of pulses/litre as the flow part, and for this flow sensor type the CCC code must be CCC > 100.

Example: CCC=119 fits an electronic meter with 100 pulses/litre and typical qp is 1.5 m³/h.

V1 and V2 are connected as shown in below diagram.

	<b>V1</b>	<b>V2</b>
<b>Red (3.6 V)</b>	9	9
<b>Yellow (Signal)</b>	10	69
<b>Blue (GND)</b>	11	11

*Table 2*

**7.1.3.1 Use of Pulse Transmitter between ULTRAFLOW® and SVM S6**

In general it is permissible to use up to 10 m cable between SVM S6 and ULTRAFLOW®. If longer cable is required, a Pulse Transmitter can be inserted between ULTRAFLOW® and SVM S6. In this way the cable length can be extended up to 50 m.

When a Pulse Transmitter is used between ULTRAFLOW® and SVM S6, volume pulses from the flow meter will be transferred to the calculator. However, the calculator is unable to data communicate with the flow meter. In order to avoid erroneous info codes it is, therefore, necessary to deselect the info codes, which are based on data communication between SVM S6 and ULTRAFLOW® 54 (Info = 16-1024-2048-128-4096-8192-16384-32768).

The above-mentioned info codes can be deselected by means of the PC-program METERTOOL, either by changing from CCC-code 4xx to 1xx, or by using the "Info code setup" function under "Utility". See paragraph 13.2.4 Info code setup.

### 7.2 Flow sensor with active 24 V pulse output ④

When SVM S6 is connected to "industrial" flow sensors with a 24 V active pulse output, the connection board type 66-99-614 must be used in SVM S6 type S6-B type or S6-D, with a 4 wire temperature sensor connection.

S6-D is mounted with 66-99-614 from the factory.

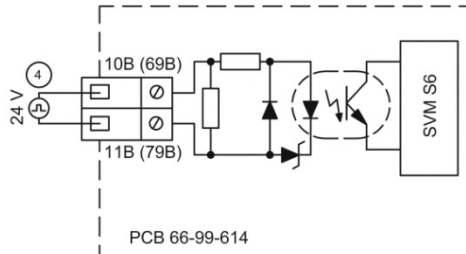

**Technical data**

Pulse input voltage	12...32 V
Pulse current	Max. 12 mA at 24 V
Pulse frequency	Max. 128 Hz
Pulse duration	Min. 3 msec.
Cable length V1 and V2	Max. 100 m (including min. 25 cm distance to other cables)
Galvanic insulation	The inputs V1 and V2 are both individually insulated and insulated from SVM S6
Insulation voltage	2 kV
Main supply	24 VAC or 230 VAC
Battery life time	When using V1: 12+1 years When using both V1 and V2: 10 years

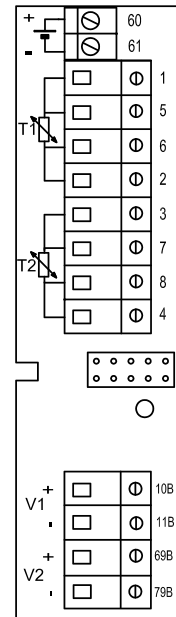

If in addition, a data communication module is used in SVM S6 the battery lifetime will be reduced further. See paragraph 9.2 for further details.

7.2.1 Connection examples

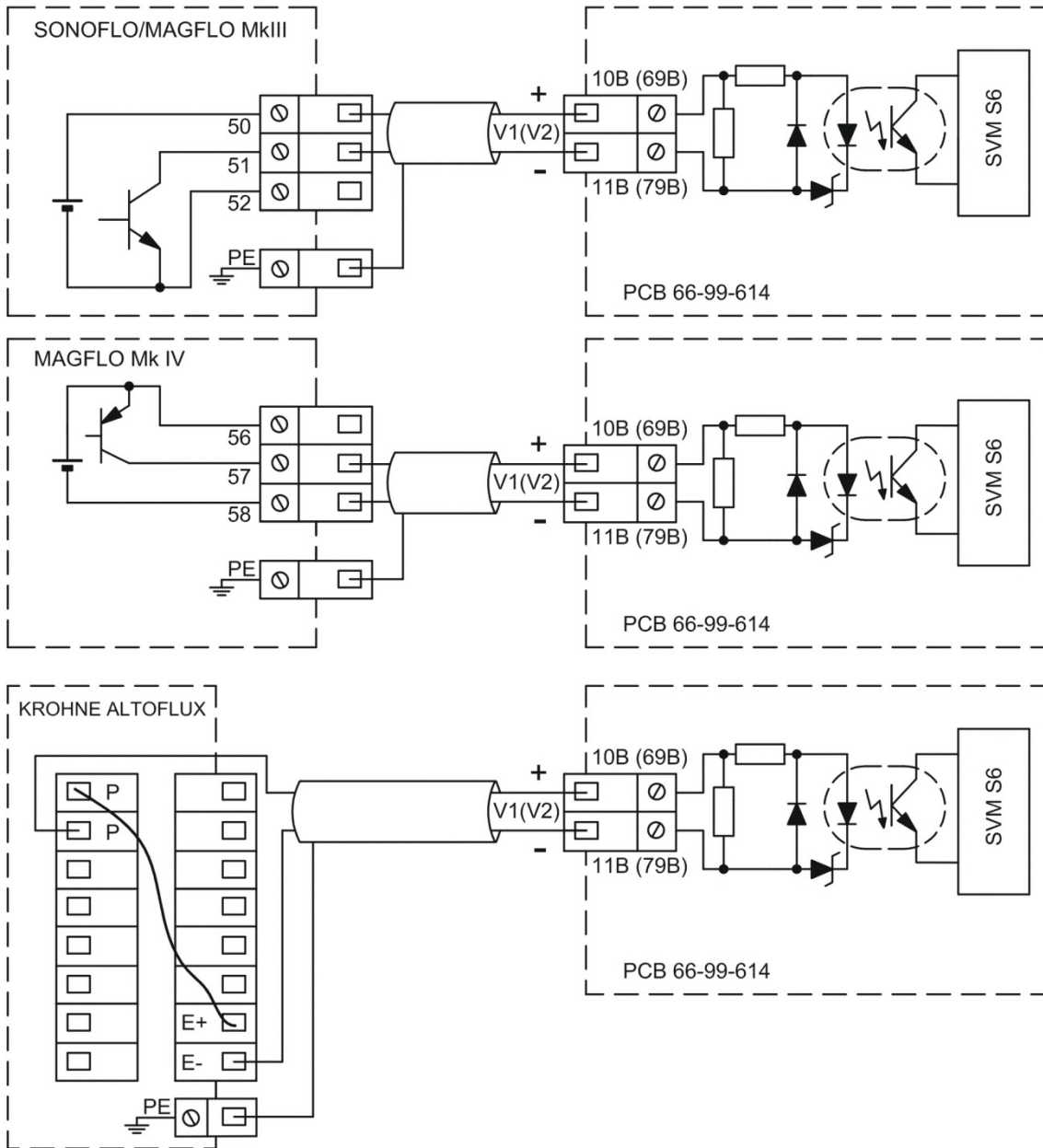

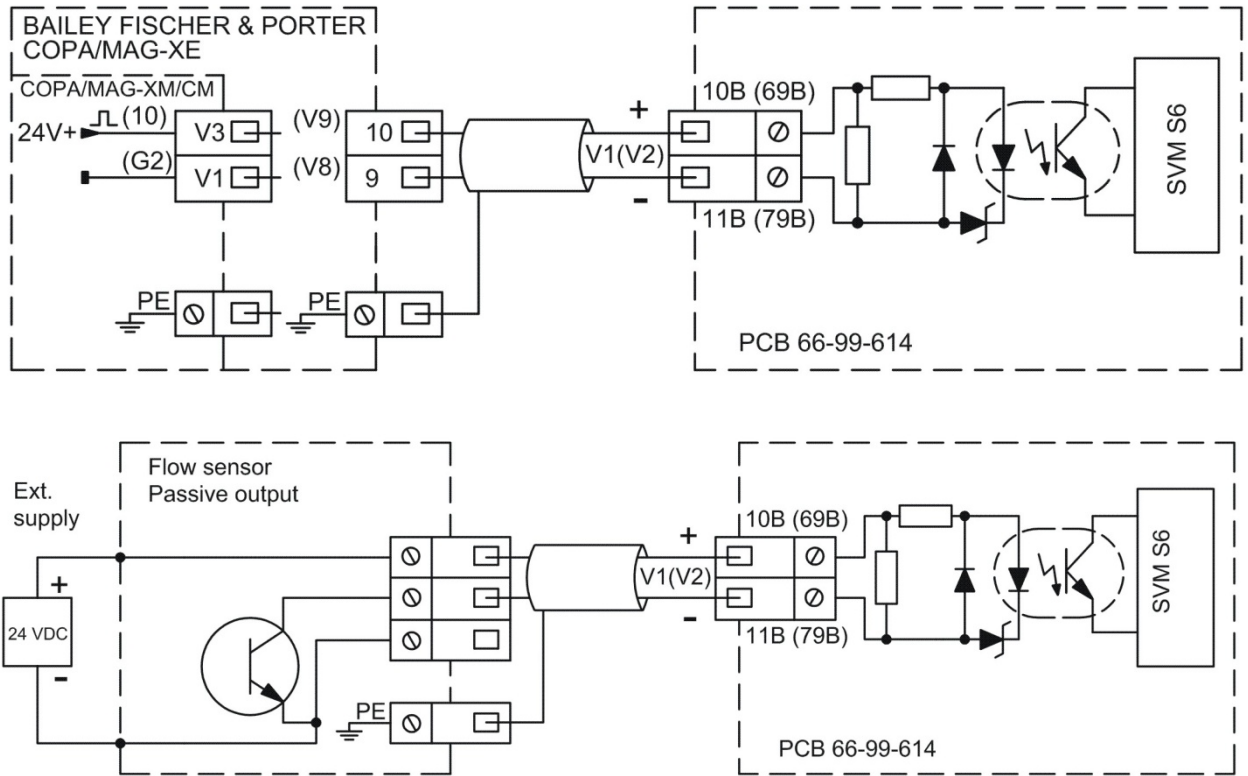

Figure 5

**7.2.2 Flow sensor coding**

In connection with installation it is important that both the flow sensor and the SVM S6 are programmed correctly. Below table states the possibilities:

CCC no.	Pre-counter	Flow factor	Number of decimals on the display					l/pulse	Pulse/l	Qp range [m³/h]	Qs [m³/h]	Type	Flow sensor
			MWh Gcal	GJ	m³ [ton]	m³/h	MW						
201	100	235926	2	1	1	1	2	1	1	10...100	75	FUS380 DN50-65	K-M
202	40	589815	2	1	1	1	2	2.5	0.4	40...200	240	FUS380 DN80-100	K-M
203	400	589815	1	0	0	1	2	2.5	0.4	100...400	500	FUS380 DN125	K-M
204	100	235926	1	0	0	0	1	10	0.1	150...1200	1600	FUS380 DN150-250	K-M
205	20	1179630	1	0	0	0	1	50	0.02	500...3000	3600	FUS380 DN300-400	K-M

Table 3

### 7.3 Pulse inputs VA and VB

In addition to the pulse inputs V1 and V2 SVM S6 has two extra pulse inputs, VA and VB, to collect and accumulate pulses remotely, e.g from cold-water meters and electricity meters. The pulse inputs are physically placed on the "base modules" as for instance on the "data/pulse input module" that can be placed in the connection base, however, accumulation and data logging of values are made by the calculator.

The pulse inputs VA and VB function independantly of the other inputs/outputs and thereby they are not included in any energy calculations.

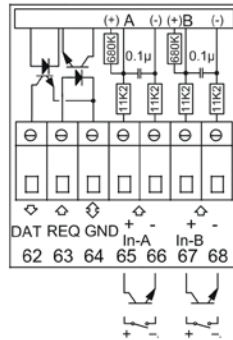

Both pulse inputs are constructed identically and can individually be set up to receive pulses from water meters with max. 1 Hz or pulses from electricity meters with max. 3 Hz.

Configuration to correct pulse value is made at the factory on the basis of order information or are configured by means of METERTOOL. See paragraph 3.6 concerning configuration of VA (FF codes) and VB (GG codes).

SVM S6 registers the accumulated consumption for the meters connected to VA and VB and stores the registers every month and every year on the target date. To facilitate the identification during data reading it is also possible to store the meter numbers for the two meters that are connected to VA and VB. Programming is made by means of METERTOOL, or directly on the meter set-up menu, see section 6.17

The registers that can both be read on the display (by selecting a suitable DDD code) and via data communication contains the following information as well as date of yearly and monthly data:

<b>Registration type:</b>	<b>Count</b>	<b>Identification</b>	<b>Yearly data</b>	<b>Monthly data</b>
<b>VA</b> (accumulated register)	•			
Meter number VA		•		
Yearly data, up to 15 years back			•	
Monthly data, up to 36 months back				•
<b>VB</b> (accumulated register)	•			
Meter number VB		•		
Yearly data, up to 15 years back			•	
Monthly data, up to 36 months back				•

By using METERTOOL the registers VA and VB can be preset to the value of the connected meters at the time of installation.

**7.3.1 Display example, VA**

In the example below VA is configured to FF=24, which corresponds to 10 liters/pulse and a max. flow of 10 m<sup>3</sup>/h. The meter that is connected to VA has meter number 75420145 which is stored in the internal memory of SVM S6 by means of METERTOOL .



Accumulated register for VA (Input A)



Meter number for VA (max. 8 digits)



Yearly data, date for LOG 1 (last target date)



Yearly data, value for LOG 1 (last yearly reading)  
This is the accumulated volume registered on VA on the 1<sup>st</sup> June 2011.

## 8 Temperature sensors

For SVM S6 either Pt100 or Pt500 temperature sensors are used according to EN 60751 (DIN/IEC 751). A Pt100 or Pt500 temperature sensor is a platinum sensor with a nominal ohmic resistance of 100.000 Ω and 500.000 Ω, respectively, at 0.00 °C and 138.506 Ω and 692.528 Ω at 100.00 °C, respectively. All values for the ohmic resistance are laid down in the international standard IEC 751 valid for Pt100 temperature sensors. The values for the ohmic resistances in Pt500 sensors are 5 times higher. In below tables the resistance values in [Ω] are stated for every whole degree celcius for both Pt100 and for Pt500 sensors:

Pt100										
°C	0	1	2	3	4	5	6	7	8	9
0	100.000	100.391	100.781	101.172	101.562	101.953	102.343	102.733	103.123	103.513
10	103.903	104.292	104.682	105.071	150.460	105.849	106.238	106.627	107.016	107.405
20	107.794	108.182	108.570	108.959	109.347	109.735	110.123	110.510	110.898	111.286
30	111.673	112.060	112.447	112.835	113.221	113.608	113.995	114.382	114.768	115.155
40	115.541	115.927	116.313	116.699	117.085	117.470	117.856	118.241	118.627	119.012
50	119.397	119.782	120.167	120.552	120.936	121.321	121.705	122.090	122.474	122.858
60	123.242	123.626	124.009	124.393	124.777	125.160	125.543	125.926	126.309	126.692
70	127.075	127.458	127.840	128.223	128.605	128.987	129.370	129.752	130.133	130.515
80	130.897	131.278	131.660	132.041	132.422	132.803	133.184	133.565	133.946	134.326
90	134.707	135.087	135.468	135.848	136.228	136.608	136.987	137.367	137.747	138.126
100	138.506	138.885	139.264	139.643	140.022	140.400	140.779	141.158	141.536	141.914
110	142.293	142.671	143.049	143.426	143.804	144.182	144.559	144.937	145.314	145.691
120	146.068	146.445	146.822	147.198	147.575	147.951	148.328	148.704	149.080	149.456
130	149.832	150.208	150.583	150.959	151.334	151.710	152.085	152.460	152.835	153.210
140	153.584	153.959	154.333	154.708	155.082	155.456	155.830	156.204	156.578	156.952
150	157.325	157.699	158.072	158.445	158.818	159.191	159.564	159.937	160.309	160.682
160	161.054	161.427	161.799	162.171	162.543	162.915	163.286	163.658	164.030	164.401
170	164.772	165.143	165.514	165.885	166.256	166.627	166.997	167.368	167.738	168.108

Pt100, IEC 751 Amendment 2-1995-07

Table 4

Pt500										
°C	0	1	2	3	4	5	6	7	8	9
0	500.000	501.954	503.907	505.860	507.812	509.764	511.715	513.665	515.615	517.564
10	519.513	521.461	523.408	525.355	527.302	529.247	531.192	533.137	535.081	537.025
20	538.968	540.910	542.852	544.793	546.733	548.673	550.613	552.552	554.490	556.428
30	558.365	560.301	562.237	564.173	566.107	568.042	569.975	571.908	573.841	575.773
40	577.704	579.635	581.565	583.495	585.424	587.352	589.280	591.207	593.134	595.060
50	596.986	598.911	600.835	602.759	604.682	606.605	608.527	610.448	612.369	614.290
60	616.210	618.129	620.047	621.965	623.883	625.800	627.716	629.632	631.547	633.462
70	635.376	637.289	639.202	641.114	643.026	644.937	646.848	648.758	650.667	652.576
80	654.484	656.392	658.299	660.205	662.111	664.017	665.921	667.826	669.729	671.632
90	673.535	675.437	677.338	679.239	681.139	683.038	684.937	686.836	688.734	690.631
100	692.528	694.424	696.319	698.214	700.108	702.002	703.896	705.788	707.680	709.572
110	711.463	713.353	715.243	717.132	719.021	720.909	722.796	724.683	726.569	728.455
120	730.340	732.225	734.109	735.992	737.875	739.757	741.639	743.520	745.400	747.280
130	749.160	751.038	752.917	754.794	756.671	758.548	760.424	762.299	764.174	766.048
140	767.922	769.795	771.667	773.539	775.410	777.281	779.151	781.020	782.889	784.758
150	786.626	788.493	790.360	792.226	794.091	795.956	797.820	799.684	801.547	803.410
160	805.272	807.133	808.994	810.855	812.714	814.574	816.432	818.290	820.148	822.004
170	823.861	825.716	827.571	829.426	831.280	833.133	834.986	836.838	838.690	840.541

Pt500, IEC 751 Amendment 2-1995-07

Table 5

### 8.1 Sensor types

SVM S6	Type S6-	<input type="checkbox"/>	<input type="checkbox"/>	<input type="checkbox"/>	<input type="checkbox"/>	<input type="checkbox"/>
<b>Pt500 sensor set</b>						
No sensor set (always selected for Pt100)						<b>00</b>
Pocket sensor set w/1.5 m cable						<b>0A</b>
Pocket sensor set w/3.0 m cable						<b>0B</b>
Pocket sensor set w/5 m cable						<b>0C</b>
Pocket sensor set w/10 m cable						<b>0D</b>
Short direct sensor set w/1.5 m cable						<b>0F</b>
Short direct sensor set w/3.0 m cable						<b>0G</b>
3 Pocket sensors in sets w/1.5 m cable						<b>0L</b>
3 Pocket sensors in sets w/3.0 m cable						<b>0M</b>
3 Pocket sensors in sets w/5 m cable						<b>0N</b>
3 Pocket sensors in sets w/10 m cable						<b>0P</b>
3 Short direct sensors in sets w/1.5 m cable						<b>Q3</b>
3 Short direct sensors in sets w/3.0 m cable						<b>Q4</b>

When other types of temperature sensors are required, eg. SVM TDA, TL or TSF/TCF, always select "No sensor set 00". This also applies for all types of Pt100 sensors.

## 8.2 Cable influence and compensation

### 8.2.1 2 wire sensor set

Small and medium-sized heat meters only need a relatively short temperature sensor length, and the 2 wire sensor set can be used with the advantage of easy installation.

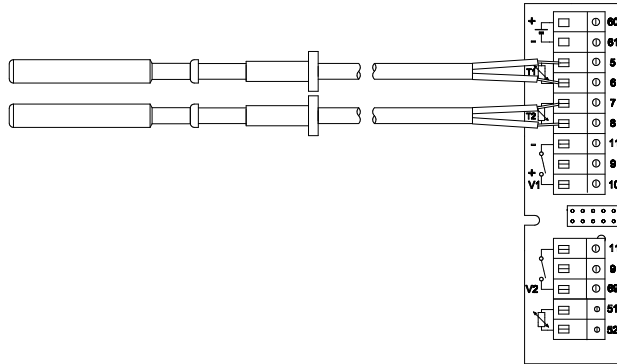

The cable length and the cross sectional area must always be identical for the 2 sensors used as a temperature sensor pair for a heat meter. The length of the cable sensors must neither be shortened nor extended.

The limitations attached to using the 2 wire sensor set according to EN 1434-2:2007 are stated in below table. Kamstrup supply Pt500 sensor sets with up to 10 m cable (2 x 0.25 mm<sup>2</sup>). Pt100 sensor sets can also be supplied and are orderd separately.

Cable cross section [mm <sup>2</sup> ]	Pt100 sensors		Pt500 sensors	
	Max. cable length [m] according to EN 1434-2:2007	Temperature increase [K/m] Copper @ 20 °C	Max. cable length [m] according to EN 1434-2:2007	Temperature increase [K/m] Copper @ 20 °C
0.25	2.5	0.450	12.5	0.090
0.50	5.0	0.200	25.0	0.040
0.75	7.5	0.133	37.5	0.027
1.50	15.0	0.067	75.0	0.013

Table 6

### 8.2.2 4 wire sensor set

For installations requiring longer cable lengths than stated in above table, we recommend a 4 wire sensor set and a SVM S6 type S6-B with 4 wire connection.

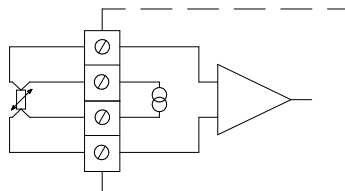

The 4 wire construction uses two conductors for testing current and the two other conductors for measuring signal. In this way, the construction will in theory not be affected by long sensor cables. However, in practice cables longer than 100 m should not be used. We recommend to use 4 x 0.25 mm<sup>2</sup>.

The connection cable should have an outside diameter of 5-6 mm to obtain optimal tightening in both SVM S6 and in the cable gland on the 4 wire sensor. The insulation material/cover of the cable should be selected based on the max. temperature in the installation. PVC cables are typically used up to 80 °C and in connection with higher temperatures silicone cables are often used.

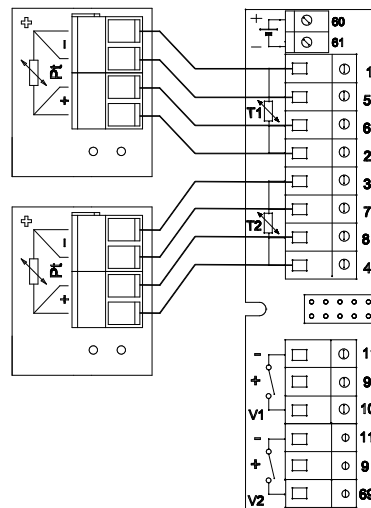

The 4 wire temperature sensors from Kamstrup SVM have a very low thermal mass, quick response time and a spacious connection head. The temperature sensors are well suited for both heating and cooling applications and are available in the lengths 85 and 120 mm, delivered with or without stainless steel pockets.

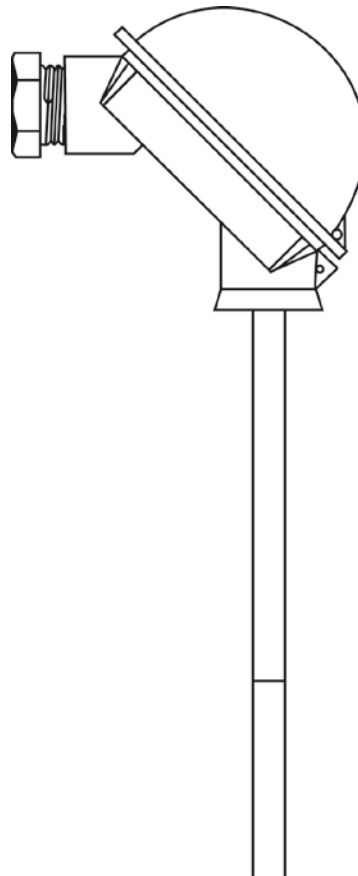

### 8.3 Pocket sensors

The Pt500 cable sensor is constructed with a 2 wire silicone cable and closed with a shrunk-on stainless steel tube with a diameter of  $\varnothing 5.8$  mm that protects the sensor element.

The steel tube is fitted in a sensor pocket (pocket) which has an inside diameter of  $\varnothing 6$  and an outside diameter of  $\varnothing 8$  mm. The sensor pockets are supplied with an R $\frac{1}{2}$  (conical  $\frac{1}{2}$ " ) connection in stainless steel with a length of 65, 90 or 140 mm. The sensor construction with separate pocket allows replacement of sensors without turning off the water flow. The large selection of pocket lengths also ensures that the sensors can be fitted in all pipe sizes.

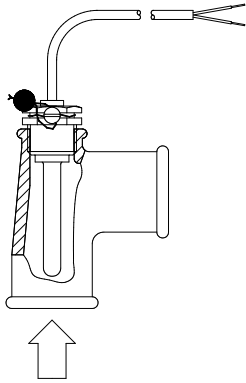

Figure 6

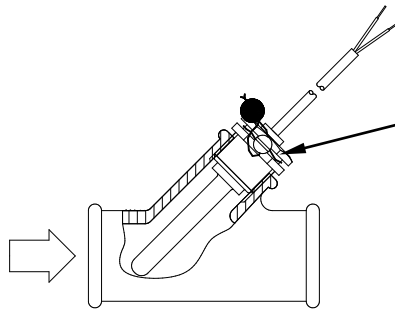

Figure 7

The stainless steel pockets is used in PN25 installations!

#### 8.3.1 Pocket sensors, SVM

SVM S6 can also be equipped with pocket sensors (PS) type TL045 i Pt100 or Pt500, with 2-wire cable and a  $\varnothing 5.2$  mm steel tube. Both the temperature sensors and the pockets are ordered separately. The pockets are available in different materials and in lengths between 34-120 mm. Cf. separate data sheet for further information.

SVM S6 can futher be equipped with long pocket sensors (PL) type SVM TSF or with pockets included type TCF. SVM TSF/TCF are available for Pt100 or Pt500, with a fixed 2-wire cable or with a connection head for 1- or 4-wire connection. The pocket long sensors some in two different lengths, 85 or 120 mm. Cf. separate data sheet for further information.

### 8.4 Pt500 short direct sensor set

The Pt500 short direct sensor is constructed according to the European standard for thermal heat meters EN 1434-2. The sensor is constructed for fitting directly in the measuring medium, i.e. without sensor pocket. In this way an extremely fast response time on temperature changes from e.g. domestic water exchangers is obtained.

The sensor is based on a 2 wire silicone cable. The sensor tube is made of stainless steel and has a diameter of  $\varnothing 4$  mm at the tip where the sensor element is placed. Fitting can also be made directly in many flow sensor types, which reduces the installation costs.

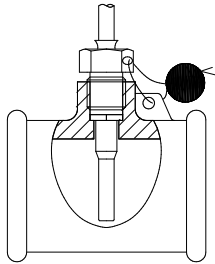

Figure 8

The sensor is fitted in special T-sections, that is available for 1/2", 3/4" and 1" pipe installations.

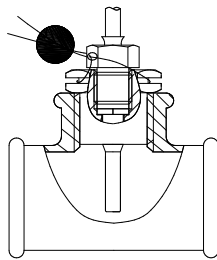

Figure 9

In addition, the short direct sensor is fitted by means of a R1/2 or R3/4 for M10 nipple in a standard 90° tee.

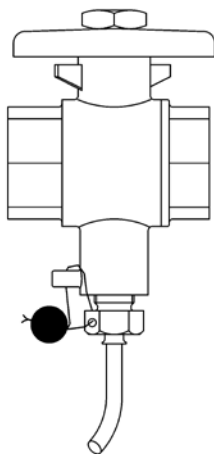

Figure 10

To obtain the best serviceability during meter replacements, the short direct sensor can be placed in a ball valve with a sensor connecting piece.

Ball valves with a sensor connecting piece are available in G1/2, G3/4 and G1.

No.	6556-474	6556-475	6556-476
	G1/2	G3/4	G1

Max. 130 °C and PN16

#### 8.4.1 Direct sensors, SVM

SVM S6 can also be equipped with short direct sensors (DS) type SVM TDA26, Pt100 or Pt500. The sensors are ordered separately and are equipped with a 2-wire cable, and a conical steel tupe with  $\varnothing 3.5$  mm at the tip where the sensor element is located. The sensors have an M10 connection thread that fits directly into many flow sensors or in a T-piece. Also cf. separate sheet for further information.

## 9 Voltage supply

SVM S6 must always be supplied internally with 3.6 VDC ( $\pm 0.1$  VDC) on terminals 60(+) and 61(-). This is obtained by one of the following supply modules:

Supply	SVM S6	Type S6-	□	□	□□	□	□□	□	□	□□
Battery, D-cell						2				
230 VAC high power isolated SMPS						3				
24 VAC high power isolated SMPS						4				
230 VAC isolated linear supply						7				
24 VAC isolated linear supply						8				

The above supply modules are all included in the extensive type test made on SVM S6. Within the frameworks of the type approval, the CE declaration and the factory guarantee, no other types of supply modules must be used than those mentioned above.

### 9.1 Integral D-cell lithium battery

A lithium D-cell battery (Kamstrup type 66-00-200-100) must be used for the meter. The battery is placed at the right in the base unit and can easily be replaced just by using a screwdriver.



The battery lifetime partly depends on the temperature to which the battery is exposed and partly of the selected meter application.

## 9.2 Battery lifetimes

Supply options and battery lifetime for wall mounted SVM S6 with ULTRAFLOW® 54

Estimated battery lifetime in years.

<b>Top ⇒ Base ↓</b>	<b>67-00</b> Without Top module	<b>67-02</b> ΔE <b>67-09</b> ΔV	<b>67-03</b> PQ <b>67-07</b> M-Bus	<b>67-05</b> Data	<b>67-0A</b> 2 pulse out + scheduler	<b>67-0B</b> 2 pulse out + prog. datalogger	<b>602-0C</b> 2 pulse out
<b>67-00-00</b> Without base module	12+1	12+1	<b>Mains only</b>	12+1	10	9	10
<b>67-00-10</b> Data+ pulse inp.	Monthly: 12 daily: 12 hourly: 10 min.: 5	Monthly: 12 daily: 12 hourly: 10 min.: 5	<b>Mains only</b>	Monthly: 12 daily: 12 hourly: 10 min.: 5	Monthly: 10 daily: 9 hourly: 8 min.: 5	Monthly: 9 daily: 8 hourly: 7 min.: 4	Monthly: 10 daily: 9 hourly: 8 min.: 5
<b>67-00-20/27/28/29</b> M-Bus+ pulse inp.	Monthly: 12 daily: 11 hourly: 9 min.: 1	Monthly: 12 daily: 11 hourly: 9 min.: 1	<b>Mains only</b>	Monthly: 12 daily: 11 hourly: 9 min.: 1	Monthly: 10 daily: 9 hourly: 7 min.: 1	Monthly: 9 daily: 8 hourly: 6 min.: 1	Monthly: 10 daily: 9 hourly: 7 min.: 1
<b>67-00-22</b> Prog. datalogger + analog inputs	<b>Mains only</b>	<b>Mains only</b>	<b>Mains only</b>	<b>Mains only</b>	<b>Mains only</b>	<b>Mains only</b>	<b>Mains only</b>
<b>67-00-23</b> 0/4-20 Analogue Out	<b>Mains only</b>	<b>Mains only</b>	<b>Mains only</b>	<b>Mains only</b>	<b>Mains only</b>	<b>Mains only</b>	<b>Mains only</b>
<b>67-00-24</b> LonWorks +pulse inp.	<b>Mains only</b>	<b>Mains only</b>	<b>Mains only</b>	<b>Mains only</b>	<b>Mains only</b>	<b>Mains only</b>	<b>Mains only</b>
<b>67-00-25/26</b> RF+p/i, read by Hand Held Terminal	Monthly: 10 daily: 9 hourly: - min.: -	Monthly: 9 daily: 8 hourly: - min.: -	<b>Mains only</b>	Monthly: 9 daily: 8 hourly: - min.: -	Monthly: 8 daily: 7 hourly: - min.: -	Monthly: 7 daily: 6 hourly: - min.: -	Monthly: 8 daily: 7 hourly: - min.: -
<b>67-00-30, 602-00-35</b> WM-Bus Mode C1 + pulse inp.	12+1	12+1	<b>Mains only</b>	12+1	10	9	10
<b>67-00-60</b> ZigBee + pulse inp.	<b>Mains only</b>	<b>Mains only</b>	<b>Mains only</b>	<b>Mains only</b>	<b>Mains only</b>	<b>Mains only</b>	<b>Mains only</b>
<b>67-00-62</b> Metasys N2 +pulse inp.	<b>Mains only</b>	<b>Mains only</b>	<b>Mains only</b>	<b>Mains only</b>	<b>Mains only</b>	<b>Mains only</b>	<b>Mains only</b>
<b>602-00-64</b> SIOX	<b>Mains only</b>	<b>Mains only</b>	<b>Mains only</b>	<b>Mains only</b>	<b>Mains only</b>	<b>Mains only</b>	<b>Mains only</b>
<b>602-00-66</b> BACnet MS/TP + pulse inp.	<b>Mains only</b>	<b>Mains only</b>	<b>Mains only</b>	<b>Mains only</b>	<b>Mains only</b>	<b>Mains only</b>	<b>Mains only</b>
<b>602-00-80</b> GSM/GPRS	<b>HP Mains only</b>	<b>HP Mains only</b>	<b>HP Mains only</b>	<b>HP Mains only</b>	<b>HP Mains only</b>	<b>HP Mains only</b>	<b>HP Mains only</b>
<b>602-00-81</b> 3G GSM/GPRS modul (GSM8H)	<b>HP Mains only</b>	<b>HP Mains only</b>	<b>HP Mains only</b>	<b>HP Mains only</b>	<b>HP Mains only</b>	<b>HP Mains only</b>	<b>HP Mains only</b>
<b>602-00-82</b> Ethernet/IP	<b>HP Mains only</b>	<b>HP Mains only</b>	<b>HP Mains only</b>	<b>HP Mains only</b>	<b>HP Mains only</b>	<b>HP Mains only</b>	<b>HP Mains only</b>
<b>602-00-84</b> High Power RF + pulse inp.	<b>HP Mains only</b>	<b>HP Mains only</b>	<b>HP Mains only</b>	<b>HP Mains only</b>	<b>HP Mains only</b>	<b>HP Mains only</b>	<b>HP Mains only</b>

- Note 1: Battery lifetime in [years] at one data reading per month, day, hour or minute.
- Note 2: Battery temperature between 30 and 45°C (pipe mounted calculator) will reduce the lifetime by 1-3 years.
- Note 3: Connection of 2 ULTRAFLOW® will reduce the lifetime by 3 years.
- Note 4: With top module 67-0B, log intervals from 60 to 1 min. will reduce the battery lifetime by up to 3 years.
- Note 5: Pulse outputs are calculated at an average of 50% qp for standard CCC-codes and 32 ms. pulse duration.

### 9.3 High Power supply module 230 VAC

This PCB module is galvanically separated from the mains supply and is suited for direct 230 V mains installation. The module is a **Switch Mode Power Supply (SMPS)** that meets the demands for double insulation when the calculator top is mounted. The power consumption is less than 1.7 VA/1 W.

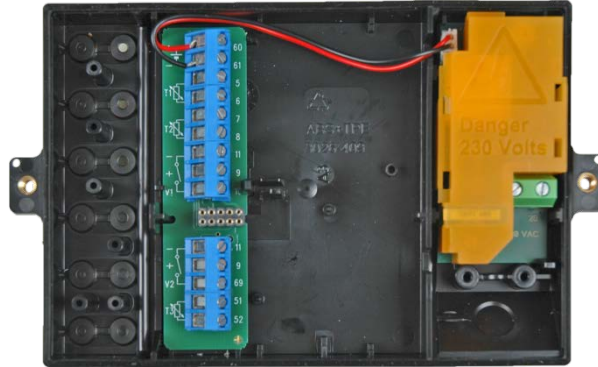

National electricity installation requirements must be met. The 230 VAC module must be connected/disconnected by the utility staff, whereas the fixed 230 V installation for the switch cabinet must only be made by an authorised electrician. If mains disappears, this SMPS will keep the meter running for a few seconds.

### 9.4 High Power supply module 24 VAC

This PCB module is galvanically separated from the 24 VAC mains supply and is suited for industrial installations with joint 24 VAC supply and individual installations supplied from a separate 230/24 V safety transformer in the switch cabinet. The module is a **Switch Mode Power Supply (SMPS)** that meets the demands for double insulation when the calculator top has been mounted. The power consumption is less than 1.7 VA/1 W.

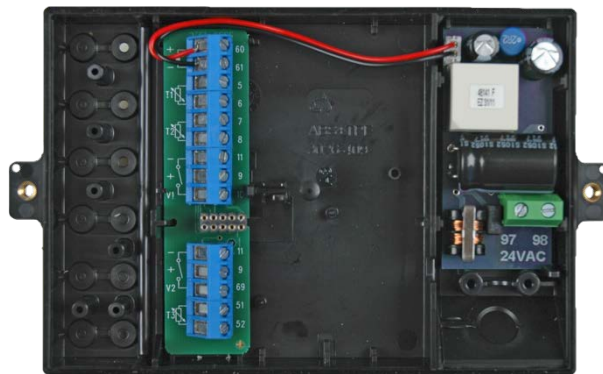

National electricity installation requirements must be met. The 24 VAC module must be connected/disconnected by the utility staff, whereas installation of 230/24 V in the switch cabinet must only be made by an authorised electrician.

The module is specially suited for installation together with a 230/24 V safety transformer, e.g. type 66-99-403, that can be installed in the switch cabinet before the safety relay. When the transformer is used the power consumption will be less than 1.7 W for the entire meter including the 230/24 V transformer. If mains disappears, this SMPS will only keep the meter running for a few seconds.

## 9.5 Supply module 230 VAC

This PCB module is galvanically separated from the mains supply and is suited for direct 230 V mains installation. The module contains a double chamber safety transformer that meets the demands for double insulation when the calculator top has been mounted. The power consumption is less than 1.5 VA/0.7 W.



National electricity installation requirements must be met. The 230 VAC module must be connected/disconnected by the utility staff, whereas the fixed 230 V installation for the switch cabinet must only be made by an authorised electrician. If mains disappears, this power supply will keep the meter running for a few minutes.

## 9.6 Supply module 24 VAC

This PCB module is galvanically separated from the 24 VAC mains supply and is suited for industrial installations with joint 24 VAC supply and individual installations supplied from a separate 230/24 V safety transformer in the switch cabinet. The module contains a double chamber safety transformer that meets the demands for double insulation when the calculator top has been mounted. The power consumption (without an external 230/24 V transformer) is less than 1.5 VA/0.7 W.

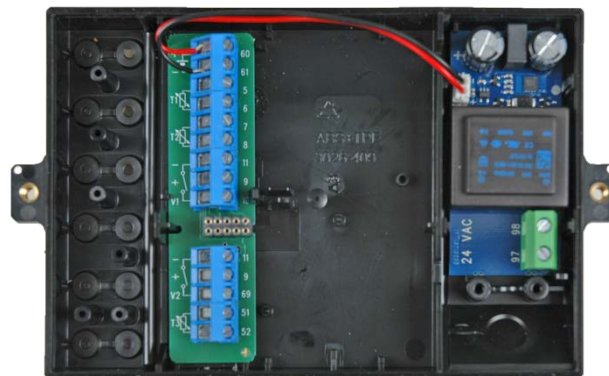

National electricity installation requirements must be met. The 24 VAC module must be connected/disconnected by the utility staff, whereas installation of 230/24 V in the switch cabinet must only be made by an authorised electrician.

The module is especially suited for installation together with a 230/24 V safety transformer, e.g. type 66-99-403, that can be installed in the switch cabinet before the safety relay. When the transformer is used the power consumption will be less than 2.2 W for the entire meter including the 230/24 V transformer. If mains disappears, this power supply will keep the meter running for a few minutes.



**9.6.1 Requirements for the transformer 230/24V**

Transformer type 66-99-403 is recommended for connection to a 24 VAC high-power supply module. Other types may be used, however it ought to be secured that the transformer has the correct output voltage. This is the case if the transformer has an off-load voltage of  $\leq 26$  VAC and a voltage of  $\geq 20$  VAC loaded at 100 Ohm (or at two times 47 Ohm connected in series).

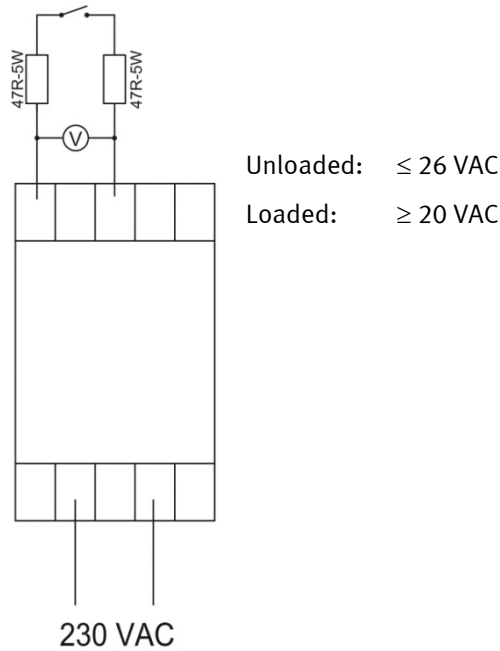

Figure 11

### 9.7 Exchanging the supply unit

The power supply unit for SVM S6 can be exchanged from mains supply to battery or vice versa as the needs at the utility change. In this way, mains supplied meters can be exchanged for battery meters with advantage in connection with buildings in the course of construction, as the mains supply may be unstable or lack periodically.

Exchange from battery to mains supply does not require reprogramming, as SVM S6 does not contain an information code for worn out batteries.

However, exchange from mains supply to battery must not be made on SVM S6 with following base modules:

Base module	SVM S6	Type S6-	□	□	□□	□	□□	□	□	□□
Prog. data logger + RTC + 4...20 mA inputs + pulse inputs					22					
0/4...20 mA outputs					23					
LonWorks + pulse inputs					24					
ZigBee 2.4 GHz int.ant. + pulse inputs					60					
Metasys N2 (RS485 + pulse inpts					62					
SIOX module (Auto detect Baud rate)					64					
BACnet MS/TP + pulse inputs					66					
GSM/GPRS module (GSM6H)					80					
3G GSM/GPRS modul (GSM8H)					81					
Ethernet/IP module (IP201)					82					
High Power Radio Router + pulse inputs					84					

See paragraph 10.1.5 re supply options for top and base modules.

### 9.8 Mains supply cables

SVM S6 is available with mains cables H05 VV-F for either 24 V or 230 V (l=1.5 m):

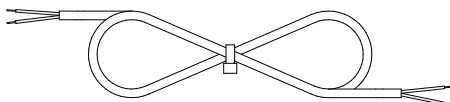

Mains cable, type 5000-286 (2x0.75 mm<sup>2</sup>), max. 6 A fuse

”H05 VV-F” is the designation for a heavy PVC cable, that stands max. 70 °C. The supply cable must therefore be installed with a sufficient distance to hot pipes and the like.

### 9.9 Back-up of data during power down

An early warning circuit and corresponding software is added, securing safety back-up of all main registers during power down. In fact, this will function as the hourly data back-up, but also during power down. This will ensure that the meter always starts up with the same display values as before the power break.

This will be effective for both 24V and 230V power break and also when the top part of SVM S6 is removed from the base, or in case of a battery failure.

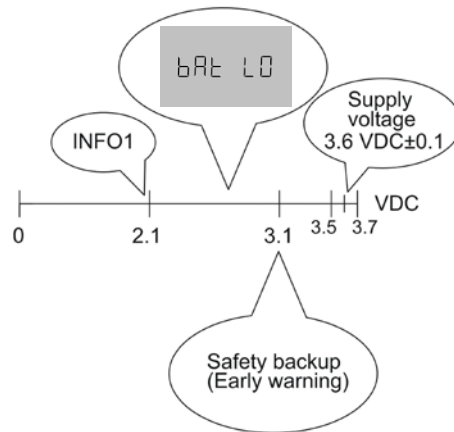

The battery has been constructed to maintain a constant voltage level of 3.6 VDC ±0,1 V throughout its entire life-time. Shortly before the battery's energy is used up completely, the voltage falls. When the battery reaches 3.1 V the meter makes a safety back-up. When the voltage is further reduced, "bAt LO" is displayed to indicate that the battery voltage of the meter is too low to carry out measurements. At 2.1 V info code = 1 is logged in the info event logger with time and date, to make it possible to see when the battery's energy has been completely used up.

## 10 Plug-in modules

Plug-in modules can be added to SVM S6 both in the calculator top (top modules) and in the base unit (base modules), in this way the meter adapts to a number of various applications.

All plug-in modules are included in the extensive type test which SVM S6 has gone through. Within the framework of the type approval, the CE declaration and the factory guarantee other types of plug-in modules than those mentioned below cannot be used:

### 10.1 Top modules

Top module	SVM S6	Type S6-	□	□	□□	□	□□	□	□	□□
ΔEnergy calculation			2							
PQ or Δt-limiter			3							
Data output			5							
M-Bus			7							
ΔVolume			9							
2 pulse outputs CE and CV + scheduler			A							
2 pulse outputs CE and CV + prog. data logger			B							
2 Pulse outputs CE and CV			C							

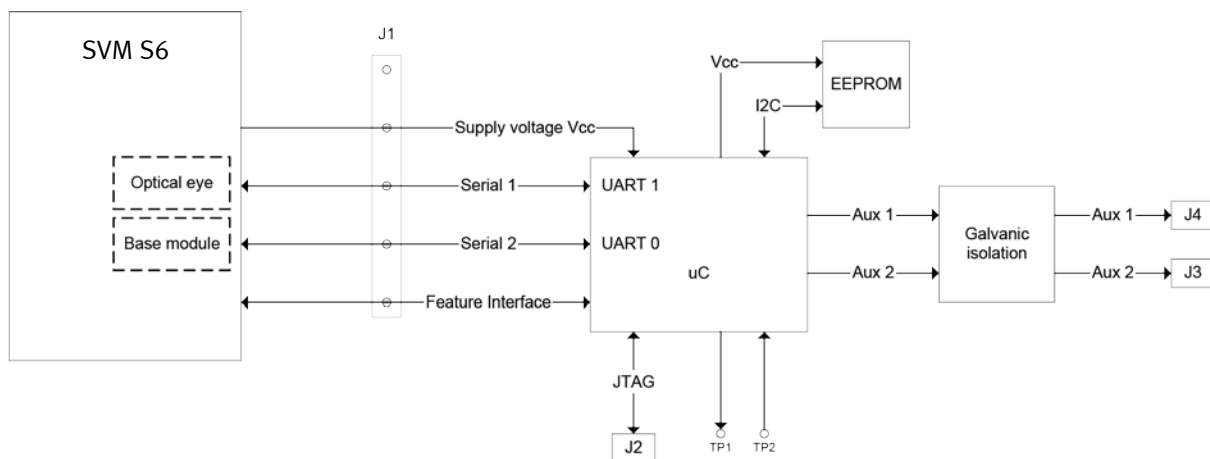

Topmodule functional block diagram

The top modules are built up on the above joint hardware platform. The application program in the micro controller and the component location vary according to the task.

Modules developed for MULTICAL® 601/602 can also be used in SVM S6 (except for the 67-06 module that only works in MC601). When a top module with RTC is mounted in SVM S6 the top module's RTC will not have any effect on the meter's own RTC.

10.1.1 Top module overview

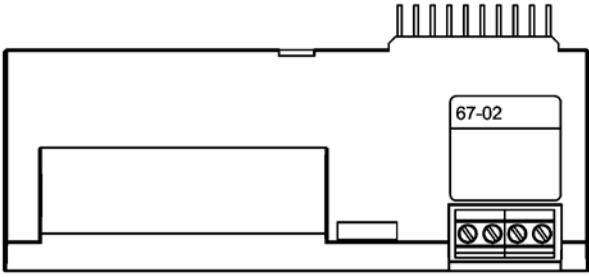
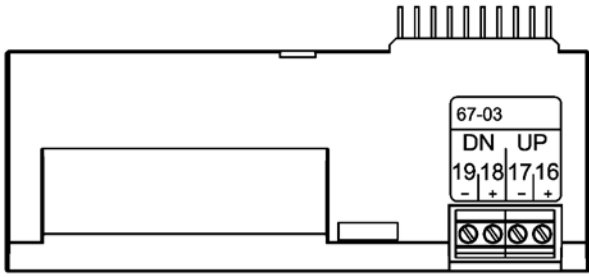
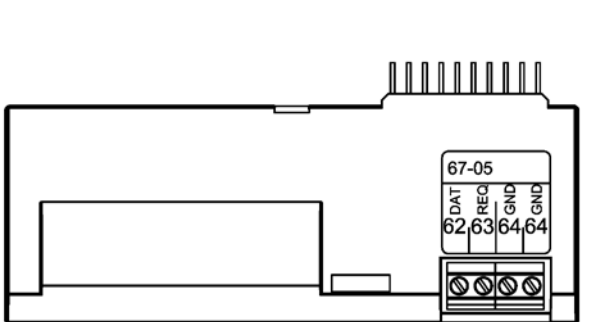
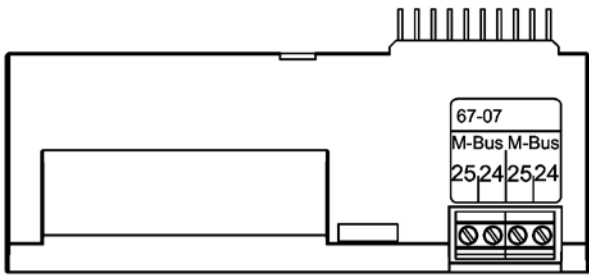
	<p><b>Type 67-02: Δ energy calculation</b>                  This top module calculates the difference between forward and return energy, whereby an expression of the tapped energy in open systems is obtained.                   Differential energy <math>dE = E_4 - E_5</math>.                   Requires <math>CCC_1 = CCC_2</math>   <i>Terminal screws are not used in this module.</i></p>
	<p><b>Type 67-03: PQ-limiter</b>                  The module has two pulse outputs which can be used for UP/DOWN control of a low-speed three-point motor-operated valve via an external solid-state relay, type S75-90-006 and a 230/24 V trafo, type 66-99-403.                   The required power and flow limits are entered into SVM S6 via the PC-program METERTOOL.                   Also see instructions: 5512-498</p>
	<p><b>Type 67-05: Data output</b>                  The module has a galvanically separated data port which functions together with the KMP-protocol. The data output can be used for e.g. connection of external communication units or other hardwired data communication which it is not expedient to carry out via the optical communication on the meter's front.                   62: DATA (Brown) – 63: REQ (White) – 64: GND (Green). Use data cable type 66-99-106 with 9-pole D-sub or type 66-99-098 with USB connector.</p>
	<p><b>Type 67-07: M-Bus</b>                  M-Bus can be connected in star, ring and bus topology. Depending on M-Bus master and cable length/cross section, up to 250 meters can be connected with primary addressing, and even more using secondary addressing.                  Cable resistance in network: &lt; 29 Ohm                  Cable capacity in network: &lt; 180 nF                  The connection polarity of terminals 24-25 is unimportant.                  The module should only be used in mains supplied meters.                   Unless otherwise stated in the order, the primary address consists of the last three digits of the meter number/customer number, but it can be changed via the PC program METERTOOL.                   In order to function correctly in a MC602, minimum program version D1, released in March 2011, is required.</p>

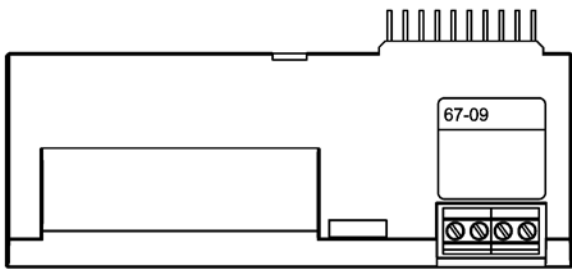
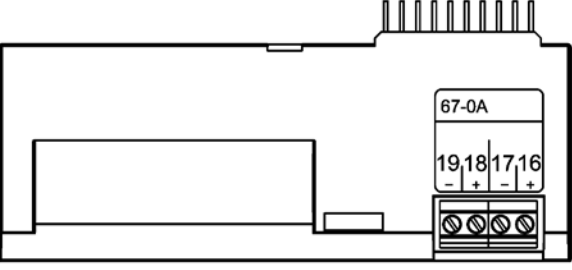
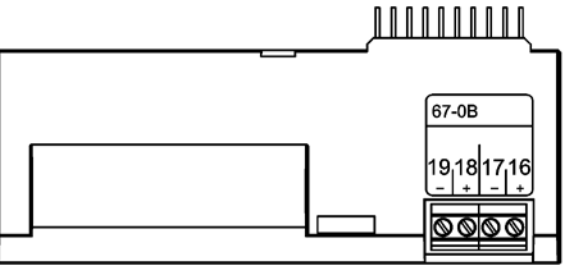
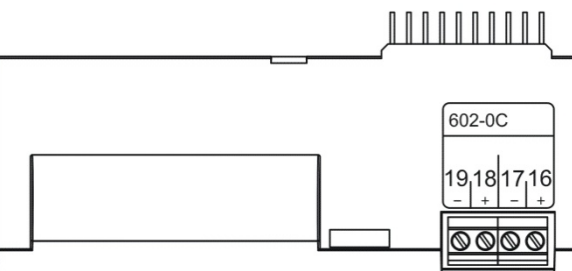
	<p><b>Type 67-09: <math>\Delta</math>Volume calculation</b></p> <p>This top module calculates the difference between forward and return volume, whereby an expression of the tapped volume in open systems is obtained.</p> <p>Differential volume <math>dV=V1-V2</math>.</p> <p>Requires CCC1=CCC2 and a suitable DDD-code.</p> <p><i>Terminal screws are not used in this module.</i></p>
	<p><b>Type 67-0A: 2 pulse outputs for CE and CV + scheduler</b></p> <p><b>See Application no. 10 in paragraph 6.2.1, Hot water meter</b></p> <p>The top module has the same functions as the 602-0C top module and furthermore the module is able to simulate a cold water temperature according to a programmed scheduler, where the programmed temperature for T2, T3 or T4 can be programmed with up to 12 individual dates/temperatures per year.</p> <p>See paragraph 10.1.2 concerning the function of the pulse outputs.</p>
	<p><b>Type 67-0B: 2 pulse outputs for CE and CV + prog. data logger</b></p> <p>Pulse output functions of this top module are identical with the functions described under top module 602-0C. Type 67-0B however, is supplied with Opto FET output for AC/DC pulses. See paragraph 2.2 Electrical data as to specifications of pulse outputs CE and CV.</p> <p>The top module is prepared for use in a Kamstrup radio network together with the High Power Radio Router base module 6020084, read data being transferred to the system software via network unit RF Concentrator.</p> <p>See paragraph 10.1.2 concerning the function of the pulse outputs.</p> <p>See paragraph 6.13 Data loggers.</p>
	<p><b>Type 602-0C: 2 pulse outputs for CE and CV</b></p> <p>This top module has two configurable pulse outputs, which are suitable for volume and energy pulses for heat meters, cooling meters and combined heat/cooling meters.</p> <p>The pulse resolution follows the display (fixed in the CCC-code). E.g. CCC=119 (qp 1.5): 1 pulse/kWh and 1 pulse/0.01 m<sup>3</sup>.</p> <p>The pulse outputs are optoinsulated and can be charged with 30 VDC and 10 mA.</p> <p>Normally, energy (CE) is connected to 16-17 and volume (CV) to 18-19, but other combinations can be selected via the PC program METERTOOL, also used to select pulse duration 32 or 100 ms.</p> <p>See paragraph 10.1.2 concerning the function of the pulse outputs.</p>

**10.1.2 Top modules 67-0A, 67-0B and 602-0C pulse outputs**

These top modules has two configurable pulse outputs, which are suitable for combined heating/cooling applications among other things:

Meter function	Output C (16-17)	Output D (18-19)	Pulse duration
Heat meter	CE+ Heat energy (E1)	CV+ Volume (V1)	32 msec.
Cooling meter	CE- Cooling energy (E3)	CV+ Volume (V1)	or
Heat/cooling meter	CE+ Heat energy (E1)	CE- Cooling energy (E3)	100 msec.

Pulse resolution follows the display (fixed in CCC-code). E.g. CCC=119: 1 pulse/kWh and 1 puls/0.01m<sup>3</sup>.

The module includes the configuration data, which will also follow the module in case of replacement.

CV- (TA3) is only used in connection with tariff EE=20.

**10.1.3 Fitting and removing the top module**

The top module is released by pressing downwards in the middle of the plastic piece on the left, and at the same time pushing the top module towards the left.

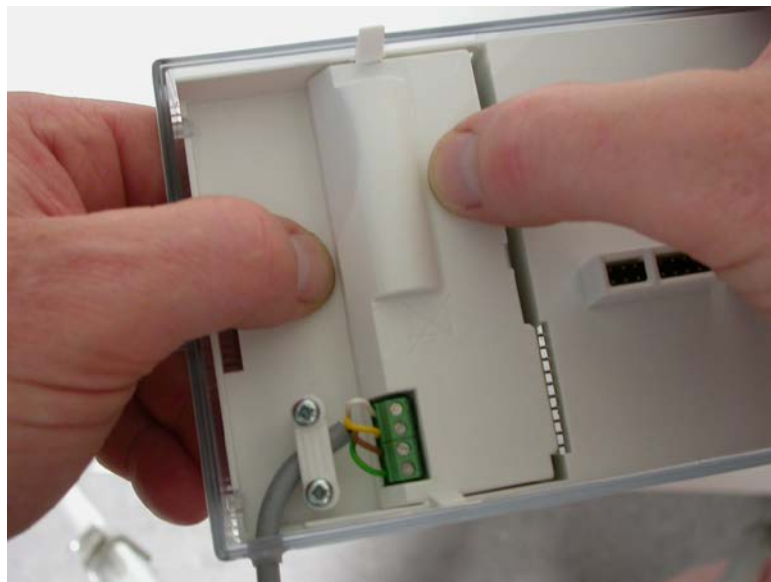

Figure 12

10.1.4 Supply options for top and base modules

<b>Top ⇒ Base ↓</b>	<b>67-02</b> ΔE <b>67-09</b> ΔV	<b>67-03</b> PQ <b>67-07</b> M-Bus	<b>67-05</b> Data	<b>67-0A</b> 2 pulse out +scheduler	<b>67-0B</b> 2 pulse out+prog.d atalog	<b>602-0C</b> 2 pulse outputs (CE/CV)
<b>67-00-10</b> Data + pulse inp.	<b>Battery or mains</b>	<b>Mains only</b>	<b>Battery or mains</b>	<b>Battery or mains</b>	<b>Battery or mains</b>	<b>Battery or mains</b>
<b>67-00-20/27/28/29</b> M-Bus + pulse inp.	<b>Battery or mains</b>	<b>Mains only</b>	<b>Battery or mains</b>	<b>Battery or mains</b>	<b>Battery or mains</b>	<b>Battery or mains</b>
<b>67-00-22</b> 4-20 inp.	<b>Mains only</b>	<b>Mains only</b>	<b>Mains only</b>	<b>Mains only</b>	<b>Mains only</b>	<b>Mains only</b>
<b>67-00-23</b> 0/4-20 out	<b>Mains only</b>	<b>Mains only</b>	<b>Mains only</b>	<b>Mains only</b>	<b>Mains only</b>	<b>Mains only</b>
<b>67-00-24</b> LonWorks + pulse inp.	<b>Mains only</b>	<b>Mains only</b>	<b>Mains only</b>	<b>Mains only</b>	<b>Mains only</b>	<b>Mains only</b>
<b>67-00-25</b> RF + pulse inp.	<b>Battery or mains</b>	<b>Mains only</b>	<b>Battery or mains</b>	<b>Battery or mains</b>	<b>Battery or mains</b>	<b>Battery or mains</b>
<b>67-00-26</b> RF + pulse inp.	<b>Battery or mains</b>	<b>Mains only</b>	<b>Battery or mains</b>	<b>Battery or mains</b>	<b>Battery or mains</b>	<b>Battery or mains</b>
<b>67-00-30</b> wM-Bus + pulse inp.	<b>Battery or mains</b>	<b>Mains only</b>	<b>Battery or mains</b>	<b>Battery or mains</b>	<b>Battery or mains</b>	<b>Battery or mains</b>
<b>602-00-35</b> wM-Bus Alt. reg. + pulse inp.	<b>Battery or mains</b>	<b>Mains only</b>	<b>Battery or mains</b>	<b>Battery or mains</b>	<b>Battery or mains</b>	<b>Battery or mains</b>
<b>67-00-60</b> ZigBee + pulse inp.	<b>Mains only</b>	<b>Mains only</b>	<b>Mains only</b>	<b>Mains only</b>	<b>Mains only</b>	<b>Mains only</b>
<b>67-00-62</b> Metasys N2 + pulse inp.	<b>Mains only</b>	<b>Mains only</b>	<b>Mains only</b>	<b>Mains only</b>	<b>Mains only</b>	<b>Mains only</b>
<b>602-00-64</b> SIOX	<b>Mains only</b>	<b>Mains only</b>	<b>Mains only</b>	<b>Mains only</b>	<b>Mains only</b>	<b>Mains only</b>
<b>602-00-66</b> BACnet MS/TP + pulse inp.	<b>Mains only</b>	<b>Mains only</b>	<b>Mains only</b>	<b>Mains only</b>	<b>Mains only</b>	<b>Mains only</b>
<b>602-00-80</b> GSM/GPRS	<b>HP Mains only</b>	<b>HP Mains only</b>	<b>HP Mains only</b>	<b>HP Mains only</b>	<b>HP Mains only</b>	<b>HP Mains only</b>
<b>602-00-81</b> 3G GSM/GPRS modul (GSM8H)	<b>HP Mains only</b>	<b>HP Mains only</b>	<b>HP Mains only</b>	<b>HP Mains only</b>	<b>HP Mains only</b>	<b>HP Mains only</b>
<b>602-00-82</b> Ethernet/IP (IP201)	<b>HP Mains only</b>	<b>HP Mains only</b>	<b>HP Mains only</b>	<b>HP Mains only</b>	<b>HP Mains only</b>	<b>HP Mains only</b>
<b>602-00-84</b> High power Radio Router + pulse inp.	<b>HP Mains only</b>	<b>HP Mains only</b>	<b>HP Mains only</b>	<b>HP Mains only</b>	<b>HP Mains only</b>	<b>HP Mains only</b>

10.1.5 Module survey for Top module 67-05 with external communication box

Top ⇒ Ext. box ↓	67-05 Data	Comments/restrictions in use
67-00-10	N/A	
67-00-20/27/28	N/A	
67-00-22	N/A	
67-00-23	N/A	
67-00-24 LonWorks	Mains only	The module type in the external communication box is not displayed in MC602. Only accumulated and actual data. LonWorks always requires mains supply.
67-00-25	N/A	
67-00-26	N/A	
67-00-30	N/A	
602-00-35	N/A	
67-00-60	N/A	
67-00-62	N/A	
602-00-64	N/A	
602-00-66	N/A	
602-00-80	N/A	
602-00-81	N/A	
602-00-82	N/A	
602-00-84	N/A	

Note: Pulse inputs for VA and VB (terminals 65-66-67-68) are not connected when a module is installed in an external connection box.

### 10.2 Base modules

The base modules for SVM S6 can be divided into 4 groups:

<b>602-00-8X</b>	Modules specifically developed for SVM S6 to be used together with 230 VAC or 24 VAC high power SMPS module.
<b>67/602-00-6X, 67/602-00-3X</b>	Modules specifically developed for SVM S6 and the KMP protocol.
<b>67-00-2X</b>	Modules specifically developed for SVM S6 and the KMP protocol.
<b>67-00-1X</b>	Modules with simple functions and without a microprocessor.

Base module	SVM S6	Typ S6-	□	□	□□	□	□□	□	□	□□
No module					<b>00</b>					
Data + pulse inputs					<b>10</b>					
M-Bus + pulse inputs					<b>20</b>					
Prog. data logger + RTC + 4...20 mA inputs + pulse inputs					<b>22</b>					
0/4...20 mA outputs					<b>23</b>					
LonWorks + pulse inputs					<b>24</b>					
Radio + pulse inputs (internal antenna) 434 or 444 MHz					<b>25</b>					
Radio + pulse inputs (external antenna connection) 434 or 444 MHz					<b>26</b>					
M-Bus module with alternative registers + pulse inputs					<b>27</b>					
M-Bus module with medium data package + pulse inputs					<b>28</b>					
Wireless M-Bus Mode C1 + pulse inputs					<b>30</b>					
Wireless M-Bus Mode C1 Alt. reg. + pulse inputs					<b>35</b>					
ZigBee 2.4 GHz int.ant. + pulse inputs					<b>60</b>					
Metasys N2 (RS485) + pulse inputs					<b>62</b>					
SIOX module (Auto detect Baud rate)					<b>64</b>					
BACnet MS/TP + pulse inputs					<b>66</b>					
GSM/GPRS module (GSM6H)		Require			<b>80</b>					
3G GSM/GPRS modul (GSM8H)		High Power			<b>81</b>					
Ethernet/IP module (IP201)		supply			<b>82</b>					
High Power Radio Router + pulse inputs		modules			<b>84</b>					

**10.2.1 Data + pulse inputs (67-00-10) (PCB 5550-369)**

The module has a galvanically separated data port that functions with the KMP protocol. The data output can be used for connection of external communication units or another wired data communication which is not suitable to perform via optical communication on the front of the meter.

See paragraph 7.3 Pulse inputs VA and VB concerning functioning of the pulse inputs.

The module comprises data connection, which can be used for external data plug, designed for use with the hand-held terminal from Kamstrup, or as a semi-permanent PC connection.

The data connection is galvanically isolated from the optocouplers which makes it necessary to use data cable type 66-99-105 or 66-99-106 in order to adjust the signal to RS-232 level, which is used by PC and with the hand-held terminal from Kamstrup. See section 11. *Data communication* for information on data strings and protocols. If the computer does not have a COM port, a data cable with USB connection, type 66-99-098, can be used.

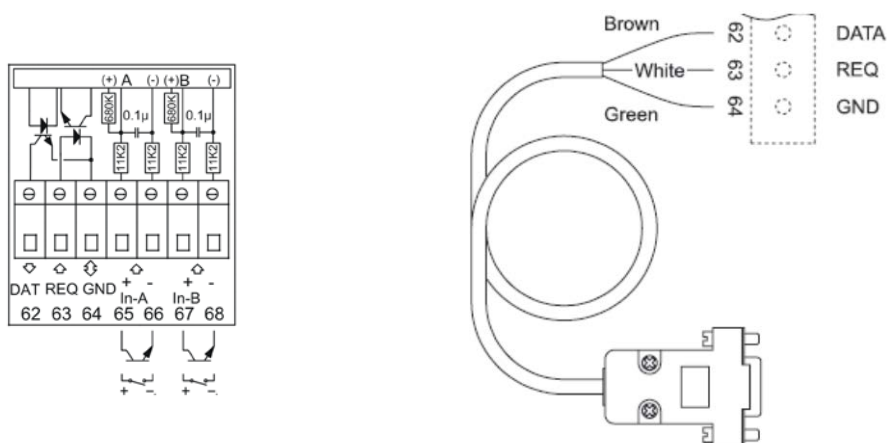

**10.2.2 M-Bus + pulse inputs (67-00-20) (PCB 5550-831)**

The M-Bus module is supplied via the M-Bus network and is independent of the meter’s own supply. M-Bus and the energy meters communicate two-way via opto couplers which gives galvanically separation between M-Bus and the meter. The module supports primary, secondary and enhanced secondary addressing.

The M-Bus module has 2 extra inputs. See paragraph 7.3 Pulse inputs VA and VB concerning functioning of the pulse inputs.

In order to function correctly in a SVM S6, minimum program version H1, released in March 2011, is required.

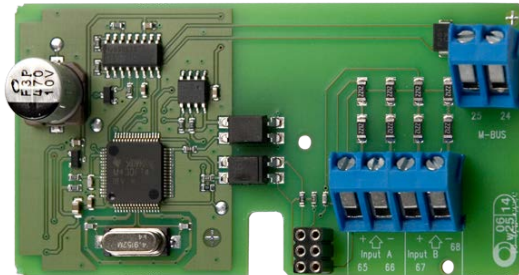

**10.2.3 Prog. data logger + RTC + 4...20 mA inputs + pulse inputs (67-00-22) (PCB 5550-925)**

The module has connection possibility for two pressure transmitters on terminals 57, 58 and 59 and can be adjusted for current reading or pressure ranges of 6, 10 or 16 bar.

The module is prepared for remote reading, data from meter/module being transferred to the system software via the connected external GSM/GPRS modem on terminals 62, 63 and 64.

Furthermore, the module has two extra pulse inputs, see section 7.3: Pulse inputs VA and VB as to function. The module must always be powered by 24 VAC.

Pressure transmitter requirements: 4...20 mA, 2-wire, loop-powered, loop voltage max. 16 VDC (e.g. type CTL from Baumer A/S)

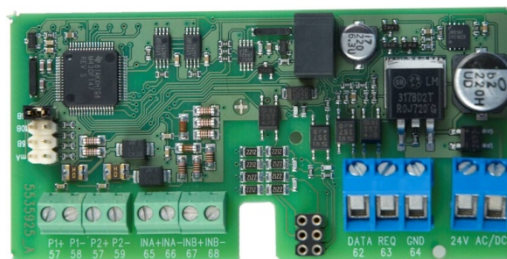

**10.2.4 0/4...20 mA outputs (67-00-23) (PCB 5550-1005)**

The module is furnished with two active analogue outputs, which can both be configured for 0...20 mA or for 4...20 mA. In addition, the outputs can be configured to any measuring value (power, flow, or temperature) and to any range scaling. All values of the two analog outputs are updated every 10 seconds. The total response time however may be up to 30-40 seconds including the response time for the flow sensor, the calculator and the digital to analog conversion. This response time has to be considered when using the analog outputs for other purposes than remote displaying.

The module must be mounted in SVM S6. It cannot be used separately together with flow meters. The configuration is carried out via the menu "Bottom module" in METERTOOL.

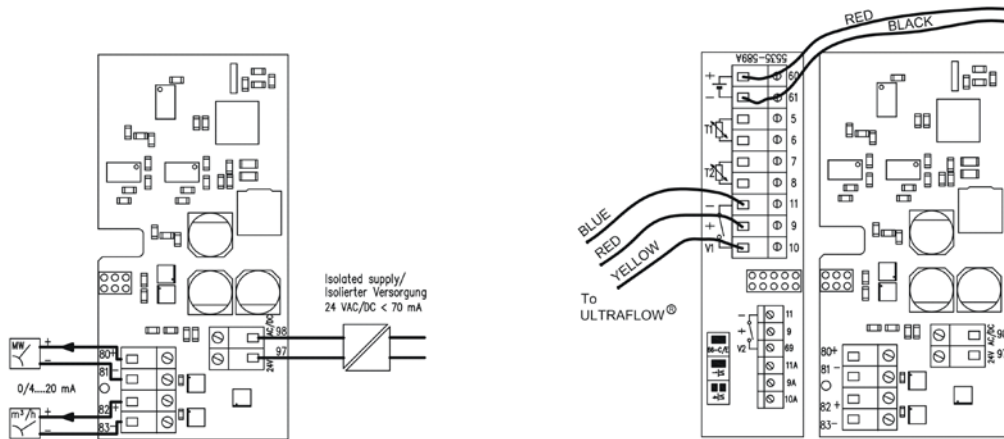

**10.2.5 LonWorks + pulse inputs (67-00-24) (PCB 5550-1128)**

The LON-module is used for data transfer from SVM S6 either for data reading or for regulation purposes via the LON-bus, which is ideal for climate control and building automation among other things. The high-speed data communication makes it possible to connect many applications to a LON-network.

The cabling between the LON-module and the other LON-nodes consists of standard twisted pair cable of up to 2700 m length at bus topology or 500 m length at free topology.

The module requires that SVM S6 is externally supplied (24-VAC /230-VAC), battery supply of SVM S6 is not possible. See paragraph 7.3 as to the function of pulse inputs VA and VB.

Regarding network variable list (SNVT) and further information on the LonWorks module we refer to data sheet 5810-1144. GB-version 5810-1043 and DE-version 5810-1044. As to installation we refer to Installation instructions 5512-1101 (DK) or 5512-1105 (GB).

As the module is de-energised when the calculator top is not mounted, it is not possible to send Neuron ID by activating the button on the module.

Neuron ID is sent by simultaneous activation of both front plate keys of SVM S6. When "Call" is displayed the Neuron ID has been sent.

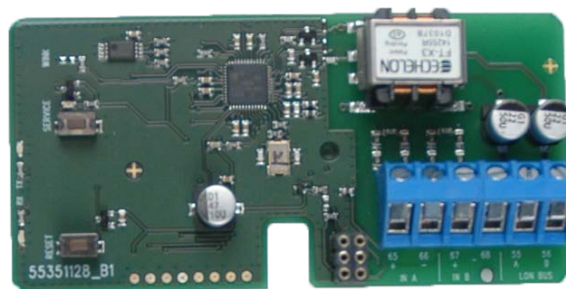

**10.2.6 Radio + pulse inputs (67-00-25/26) (PCB 5550-608/640)**

The radio module is supplied as standard to operate in a licence-free frequency band but can also be supplied to other frequencies requiring licence.

The radio module is prepared to form part of a Kamstrup radio network, where read data automatically is transferred to system software via the network components RF Router and RF Concentrator.

The radio module has 2 extra inputs. See paragraph 7.3 Pulse inputs VA and VB regarding functioning of the pulse inputs.

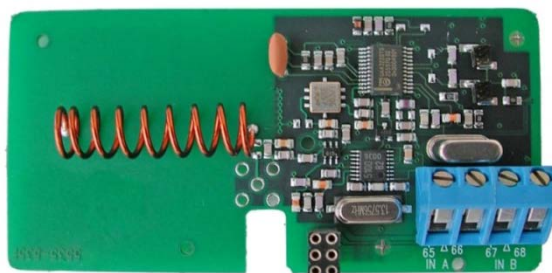

67-00-25: Internal antenna

67-00-26: External antenna connection

**10.2.7 M-Bus module with alternative registers + pulse inputs (67-00-27) (PCB 5550-997)**

The M-Bus module is supplied via the M-Bus network and is independent of the meter’s own supply. M-Bus and the energy meters communicate two-way via opto couplers which gives galvanically separation between M-Bus and the meter. The module supports primary, secondary and enhanced secondary addressing.

The M-Bus module has 2 extra inputs. See paragraph 7.3 Pulse inputs VA and VB concerning functioning of the pulse inputs.

In order to function correctly in a SVM S6, minimum program version F1 released in April 2011, is required.

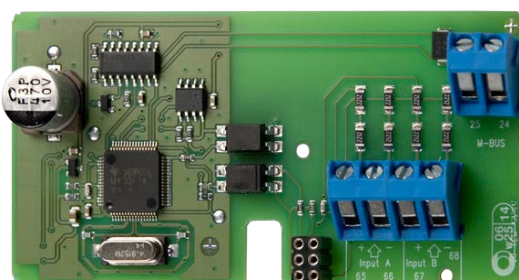

**10.2.8 M-Bus module with medium data package + pulse inputs (67-00-28) (PCB 5550-1104)**

A new M-Bus base module has been developed for SVM S6/MULTICAL® 602 and can solely be used in SVM S6/MULTICAL® 602.

The “Error hour counter” has been added to the M-Bus telegram and following registers has been removed: TA2, TA3 in actual and target data and E8, E9, TL2, TL3 in manufacture specified data.

In order to function correctly in a SVM S6, minimum program version D1 released in April 2011, is required.

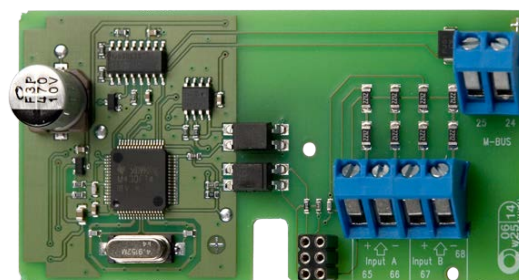

**10.2.9 Wireless M-Bus + 2 pulse inputs (67-00-30, 602-00-35) (PCB 5550-1098/1200)**

The radio module has been designed to form part of Kamstrup's hand-held Wireless M-Bus Reader systems, which operate within the unlicensed frequency band in the 868 MHz area.

The module fulfils the C-mode specifications of prEN13757-4 and can thus form part of other systems using Wireless M-Bus C-mode communication.

The radio module comes with internal antenna and external antenna connection as well as two pulse inputs (VA + VB). Paragraph 7.3 “Pulse inputs VA and VB” describes how the pulse inputs function.

The Wireless M-Bus radio transmitter is switched off before dispatch from the factory. It switches on automatically when one litre of water has run through meter. The radio transmitter can also be switched on by making a forced call (keep both front keys activated for approx. 5 sec. until CALL is displayed).

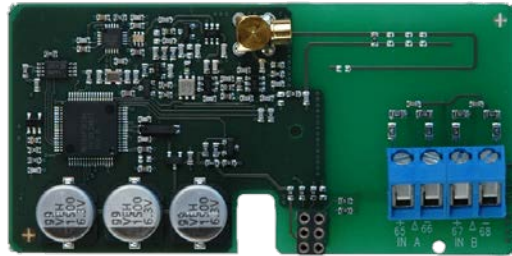

**10.2.10 ZigBee + 2 pulse inputs (67-00-60) (PCB 5550-992)**

The ZigBee module is mounted direct in the meter and is powered by the meter's supply. The module operates within the 2.4 GHz area and is ZigBee Smart Energy certified. The certification secures that the meter can form part of other ZigBee networks, e.g. reading several meter types from different meter suppliers.

To be able to offer a compact solution the module uses an internal antenna.

Paragraph 7.3 “Pulse inputs VA and VB” describes how the pulse inputs function.

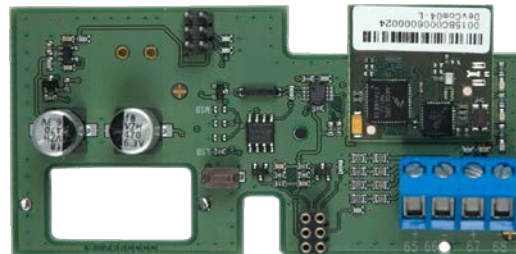

**10.2.11 Metasys N2 (RS485) + 2 pulse inputs (VA, VB) (67-00-62) (PCB 5550-1110)**

The N2 module is used for data transfer from SVM S6 heat and cooling meters to an N2 Master in a Johnson Controls System. The N2 module transfers accumulated energy and volume, current temperatures, flow and power from the heat or cooling meter to an N2 Master. N2 Open from Johnson Controls is a widespread and established field bus protocol used within building automation. The N2 module for SVM S6 ensures simple integration from Kamstrup's heat and cooling meters to N2 Open based systems. Adress area is 1-255 determined by the last three digits of the meters customer number.

Further details about the Metasys N2 module appear from data sheet 5810-925, GB-version.

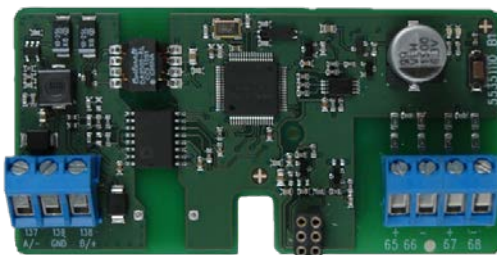

**10.2.12 SIOX module (Auto detect Baud rate) (602-00-64) (PCB 5920-193)**

SIOX is used for data reading of small and medium size groups of heat meters via cable, the data reading being presented by the main system, e.g. Mcom, Fix or Telefrang. Further information on these systems can be ordered from the supplier in question. Furthermore, a configuration tool is available from Telefrang.

The two-wire serial SIOX bus connection is optoisolated from the meter and is connected without regard to polarity (i.e. the polarity is unimportant). The module is powered by the SIOX bus. Communication speed between 300 and 19,200 baud. The module automatically uses the highest possible communication speed. The module converts data from KMP protocol to SIOX protocol.

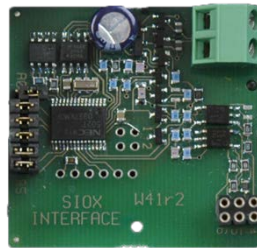

**10.2.13 BACnet MS/TP (B-ASC) RS485 + 2 pulse inputs (VA, VB) (67-00-66) (PCB 5550-1240)**

The BACnet module is used for data transfer from SVM heat, cooling and water meters into BACnet systems. The BACnet module transfers Meter number (programmable), Serial number, Accumulated heat energy (E1), Accumulated cooling energy (E3), Accumulated volume flow (V1), Flow temperature, Return temperature, Temperature difference, Actual flow, Actual power, Accumulated values from additional meters with via puls InA, InB, Info codes from the heat, cooling and water meter to the BACnet system. BACnet is a widespread and established field bus protocol used within building automation. The BACnet module for SVM ensures simple integration from Kamstrup's heat, cooling and water meters to BACnet based systems. The Module can be used as both master or slave, depending on the used MAC address.

Further details about the BACnet MS/TP module appear from data sheet 5810-1055, GB-version.

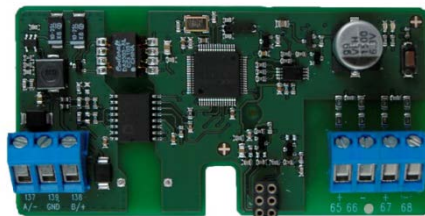

**10.2.14 GSM/GPRS module (GSM6H) (602-00-80) (PCB 5550-1137)**

The GSM/GPRS module functions as transparent communication path between reading software and SVM S6 and is used for data reading. The module includes an external dual-band GSM antenna which must always be used. The module itself includes a line of light emitting diodes indicating signal strength which are very useful during installation.

Further details about the GSM/GPRS module appear from data sheet 5810-627. GB-version 5810-628, DE-version 5810-629, SE-version 5810-630.

Regarding mounting we refer to installation instructions DK-version 5512-686, GB-version 5512-687, DE-version 5512-688.

The GSM/GPRS module (602-00-80) must be used together with the High Power mains supply (230 VAC: 602-00-00-3 and 24 VAC: 602-00-00-4).



**10.2.15 3G GSM/GPRS module (GSM8H) (67-00-81) (67-0U) (PCB - 5550-1209)**

Like GSM6H this module functions as transparent communication path between reading software and MULTICAL® 801 and is used for data reading.

However, this module supports both 2G (GSM/GPRS) and 3G (UMTS) which makes it applicable in areas with 3G coverage only.

The module requires an external Antenna, which covers both 900 MHz, 1800 MHz and 2100 MHz.

The module itself is fitted with a line of light emitting diodes indicating signal strength which are very useful during installation. Furthermore, it is indicated whether the module is connected to a 2G or a 3G network.

Additional details about the 3G module appear from data sheet 58101057 DK-version, 55101058 GB-version, 58101059 DE-version, 58101061 FI-version and 58101060 SE-version.

Regarding mounting we refer to installation instructions 55121121 DK-version, 55121122 GB-version, 55121123 DE-version, 55121124 FI-version and 55121125 SE-version.



**10.2.16 Ethernet/IP module (IP201) (602-00-82) (PCB 5550-844)**

The IP module functions as transparent communication between reading software and SVM S6 and is used for data reading. The module supports both dynamic and static addressing. This is specified in the order or selected during subsequent configuration. The module has no built-in security and must, therefore, always be used in connection with a firewall or NAT.

Further details appear from the data sheet, DK-version 5810-541, GB-version 5810-542, DE-version 5810-543, SE-version 5810-544. As far as installation is concerned we refer to installation instructions, DK version 5512-934, GB-version 5512-937, DE-version 5512-938, SE-version 5512-939.

The Ethernet/IP module (IP201) (602-00-82) must be used together with the High Power mains supply (230 VAC: 602-00-00-3 and 24 VAC: 602-00-00-4).

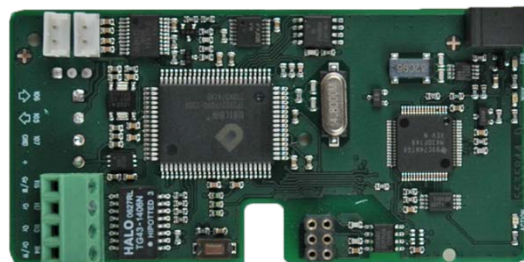

**10.2.17 High Power Radio Router + 2 pulse inputs (VA, VB) (602-00-84) (PCB 5550-1116)**

The High Power RadioRouter module has built-in router functionality and is thus optimized to form part of a Kamstrup radio network, the read data being automatically transferred to system software via the network unit RF Concentrator.

Furthermore, the module can be read by Kamstrup's hand-held reading systems, e.g. USB Meter Reader and MT Pro.

The RadioRouter module is available for operation in both licence-free and licence demanding frequencies permitting a transmitting strength of up to 500 mW. The module is by default fitted with internal antenna, connection for external antenna, and two extra pulse inputs.

See paragraph 7.3 Pulse inputs VA and VB regarding the function of the pulse inputs.

The High Power RadioRouter module (602-00-84) must be used together with the High Power mains supply (230 VAC: 602-00-00-3 and 24 VAC: 602-00-00-4).

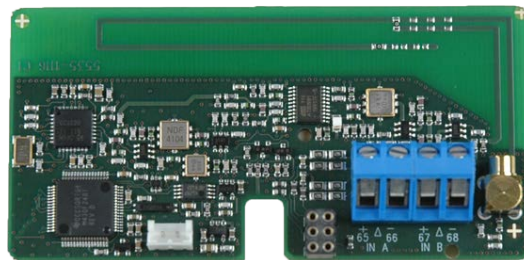

### 10.3 Retrofitting modules

Top as well as base modules for SVM S6 can be supplied separately for retrofitting. The modules are configured from the factory and ready to be mounted. Some of the modules, however, need individual configuration after installation, which can be carried out by means of METERTOOL.

Top module		Possible configuration after installation
ΔEnergy calculation	2	N/A
PQ or Δt-limiter	3	Magnification, hysteresis and possible flow cut-off must be adjusted during commissioning. All parameters and limits can be changed via METERTOOL
Data output	5	N/A
M-Bus	7	Primary and secondary M-Bus addresses can be changed via METERTOOL or M-Bus. Furthermore, monthly logger data can be selected instead of yearly logger data by means of M-Bus
ΔVolume	9	N/A
2 pulse outputs for CE and CV + scheduler	A	Configuration of pulse outputs.
2 pulse outputs for CE and CV + prog. data logger	B	Configuration of pulse outputs.
2 pulse outputs for CE and CV	C	Configuration of pulse outputs.
Base module		
Data/pulse inputs	10	Pulse values of VA and VB are changed via METERTOOL
M-Bus/pulse inputs	20	Pulse values of VA and VB are changed via METERTOOL Primary and secondary M-Bus addresses can be changed via METERTOOL or M-Bus. Furthermore, monthly logger data can be selected instead of yearly logger data via M-Bus
Prog. data logger + 4...20 mA inputs + pulse inputs	22	Pulse values of VA and VB are changed via METERTOOL
0/4...20 mA outputs	23	Config data must be programmed into the calculator by means of METERTOOL in case of retrofitting. Furthermore, all parameters can be changed via METERTOOL
LonWorks + pulse inputs	24	Pulse values of VA and VB are changed via METERTOOL. All other configurations via LonWorks
Radio + pulse inputs (internal antenna)	25	Pulse values of VA and VB are changed via METERTOOL
Radio + pulse inputs (external antenna)	26	Pulse values of VA and VB are changed via METERTOOL
M-Bus module with alternative registers + pulse inputs	27	Pulse values of VA and VB are changed via METERTOOL. Primary and secondary M-Bus addresses can be changed via METERTOOL or M-Bus. Furthermore, monthly logger data can be selected instead of yearly logger data via M-Bus
M-Bus module with medium data package + pulse inputs	28	Pulse values of VA and VB are changed via METERTOOL. Primary and secondary M-Bus addresses can be changed via METERTOOL or M-Bus. Furthermore, yearly logger data can be selected instead monthly logger via M-Bus.
Wireless M-Bus + pulse inputs	30/ 35	Pulse values of VA and VB are changed via METERTOOL
ZigBee 2.4 GHz internal antenna + pulse inputs	60	Pulse values of VA and VB are changed via METERTOOL
Metasys N2 (RS485) + pulse inputs	62	Pulse values of VA and VB are changed via METERTOOL
SIOX module (Auto detect Baud Rate)	64	N/A
BACnet MS/TP + pulse inputs	66	N/A
GSM/GPRS module (GSM6H)	80	N/A
3G GSM/GPRS modul (GSM8H)	81	N/A
Ethernet/IP module (IP201)	82	N/A
High Power Radio Router + pulse inputs	84	Pulse values of VA and VB are changed via METERTOOL

# 11 Data communication

## 11.1 SVM S6 data protocol

Internally in SVM S6 the data communication is built up with a Kamstrup Meter Protocol (KMP) that both gives a fast and flexible reading structure, and fulfils future demands on data reliability.

The KMP protocol is common for all Kamstrup consumption meters introduced in 2006 and later. The protocol is used on the optical eye and via pins to the base module. Base modules with e.g. M-Bus interface uses the KMP protocol internally and the M-Bus protocol externally.

The KMP protocol is constructed to handle point-to-point communication in a master/slave system (bus system, if required) and is used for data reading of Kamstrup energy meters.

### Software and parameter protection

The meter’s software is implemented into ROM and can after that not be changed neither deliberately nor non-deliberately. The legal parameters cannot be changed via data communication without breaking the legal seal and short-circuiting the ”total programming lock”.

### Software conformity

The check sum of the software, based on CRC16, is available via data communication and on the display.

### Integrity and authenticity of data

All data parameters contain type, measuring unit, scaling factor and CRC16 check sum. Each meter produced contains a unique identification number.

In the communication between master and slave two different formats are used. Either a data frame format or an application knowledge.

- Request from master to slave always takes place with a data frame.
- Response from the slave either takes place with a data frame or an application knowledge.

The data frame is based on the OSI model, in which the physical layer, data link layer and the application layer are used.

Number of bytes in each field	1	1	1	0-?	2	1
Field description	Start byte	Destination address	CID	Data	CRC	Stop byte
OSI – lag			Application layer			
	Data link layer					
	Physical layer					

The protocol is based on half duplex serial asynchronous communication with the setup: 8 databits, no parity and 2 stopbits. The data bit rate is 1200 or 2400 baud. CRC16 is used in both request and response.

Data is transferred byte for byte in a binary data format where the 8 databits thereby represent a byte data.

”Byte Stuffing” is used to extend the data domain.

11.1.1 SVM S6 Register ID's

ID	Register	Description
1003	DATE	Current date (YYMMDD)
60	E1	Energy register 1: Heat energy
94	E2	Energy register 2: Control energy
63	E3	Energy register 3: Cooling energy
61	E4	Energy register 4: Flow energy
62	E5	Energy register 5: Return flow energy
95	E6	Energy register 6: Tap water energy
96	E7	Energy register 7: Heat energy Y
97	E8	Energy register 8: [m <sup>3</sup> x T1]
110	E9	Energy register 9: [m <sup>3</sup> x T2]
64	TA2	Tariff register 2
65	TA3	Tariff register 3
68	V1	Volume register V1
69	V2	Volume register V2
84	VA	Input register VA
85	VB	Input register VB
72	M1	Mass register V1
73	M2	Mass register V2
1004	HR	Operational hour counter
113	INFOEVENT	Info-event counter
1002	CLOCK	Current time (hhmmss)
99	INFO	Infocode register, current
86	T1	Current flow temperature
87	T2	Current return flow temperature
88	T3	Current temperature T3
122	T4	Current temperature T4
89	T1-T2	Current temperature difference
91	P1	Pressure in flow
92	P2	Pressure in return flow
74	FLOW1	Current flow in flow
75	FLOW2	Current flow in return flow
80	EFFEKT1	Current power calculated on the basis of V1-T1-T2
123	MAX FLOW1DATE/ÅR	Date for max. this year
124	MAX FLOW1/ÅR	Max. value this year
125	MIN FLOW1DATE/ÅR	Date for min. this year
126	MIN FLOW1/ÅR	Min. value this year
127	MAX EFFEKT1DATE/ÅR	Date for max. this year
128	MAX EFFEKT1/ÅR	Max. value this year
129	MIN EFFEKT1DATE/ÅR	Date for min. this year
130	MIN EFFEKT1/ÅR	Min. value this year
138	MAX FLOW1DATE/MÅNED	Date for max. this month
139	MAX FLOW1/MÅNED	Max. value this month
140	MIN FLOW1DATE/MÅNED	Date for min. this month
141	MIN FLOW1/MÅNED	Min. value this month
142	MAX EFFEKT1DATE/MÅNED	Date for max. this month
143	MAX EFFEKT1/MÅNED	Max. value this month
144	MIN EFFEKT1DATE/MÅNED	Date for min. this month
145	MIN EFFEKT1/MÅNED	Min. value this month
146	AVR T1/ÅR	Year-to-date average for T1
147	AVR T2/ÅR	Year-to-date average for T2
149	AVR T1/MÅNED	Month-to-date average for T1
150	AVR T2/MÅNED	Month-to-date average for T2
66	TL2	Tariff limit 2
67	TL3	Tariff limit 3
98	XDAY	Target date (reading date)
152	PROG NO	Program no. ABCCCCC
153	CONFIG NO 1	Config no. DDDEE
168	CONFIG NO 2	Config. no. FFGGMN
1001	SERIE NO	Serial no. (unique number for each meter)
112	METER NO 2	Customer number (8 most important digits)
1010	METER NO 1	Customer number (8 less important digits)
114	METER NO VA	Meter no. for VA
104	METER NO VB	Meter no. for VB
1005	METER TYPE	Software edition
154	CHECK SUM 1	Software check sum
155	HIGH RES	High-resolution energy register for testing purposes
157	TOPMODUL ID	ID number for top module
158	BOTMODUL ID	ID number for base module
175	INFOHOUR	Error hour counter
234	IMPINa	l/imp. for VA
235	IMPINb	l/imp. for VB

**11.1.2 Data protocol under NDA**

Having accepted Kamstrup’s standard Non-Disclosure Agreement you can order a demonstration program in C# (.net based) as well as a detailed protocol description.

**11.2 SVM S6 communication paths**

Physically, it is possible to communicate directly as shown below. Via destination addresses data communication can be routed internally between modules and calculator.

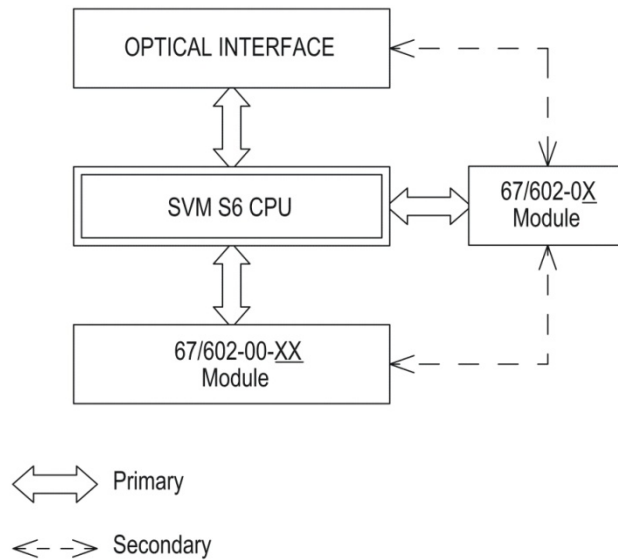

**11.3 Optical eye**

For data communication via the optical interface an optical eye can be used. The optical eye must be located at the front of the calculator, just above the IR-diode as shown on the photo below. Please note that the optical eye contains a very powerful magnet that should be protected with the magnet protector when not in use.

Different variants of the optical eye can be found in the list of accessories (see chapter 3.2.2).



**11.3.1 Current saver for the optical eye**

The circuit around the optical eye has been improved by a magnet sensor that only allows current consumption for the optical eye when a magnet (optical head) is attached to the meter.

## 12 Calibration and verification

### 12.1 High-resolution energy reading

If a need for high resolution of the energy reading arises during testing and verification it can be initialised as follows:

- Lift up the calculator top from the base unit and wait for the display to turn off
- Press both push buttons simultaneously while the calculator top is placed in the base unit again and keep pressing both push buttons until the display becomes active
- The display now shows energy with a 0.1 [Wh] resolution until one of the push buttons are activated

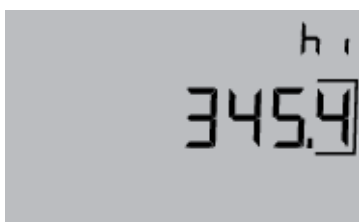

The display example shows 345.4 [Wh] which corresponds to the energy accumulated at flow = 43.00 °C and return flow = 40.00 °C and a return volume of 0.1 m<sup>3</sup>.

The high-resolution energy reading is displayed in Wh at a volume resolution of 0.01 m<sup>3</sup> (qp 1.5 m<sup>3</sup>/h). In connection with large meters the energy shown must be multiplied by 10 or 100.

m <sup>3</sup>	Wh
0.001	x 0.1
<b>0.01</b>	<b>x 1</b>
0.1	x 10
1	x 100

The high-resolution energy can be used for both heat energy (E1) and for cooling energy (E3).

#### 12.1.1 Data reading of high-resolution energy

Data reading of the register "HighRes" is possible with ID = 155.

The read value will show correct measuring unit and value irrespective of the meter size.

## 12.2 High-resolution volume for test

Should high-resolution reading of volume (V1HighRes) be required for test or verification it can be initialised as follows:

- Lift the calculator top off the connection base and wait for the display to turn off.



- Press the sub-button and re-mount the calculator top keeping the button pressed for approx. 8 seconds until the display becomes active in HighRes mode.
- The display remains active in HighRes verification mode until one of the push buttons is activated, or the calculator top is reset.



Example:

V1	V1HighRes
0.001 m3	0.0001 L
0.01 m3	0.001 L
0.1 m3	0.01 L
1 m3	0.1 L

Example of a high-resolution volume (V1HighRes) reading:

The example below starts at a display value of 573.24 m<sup>3</sup> (v1). Having activated HighRes mode the display changes to a high resolution and reading in litres appears. Subsequently, a pulse value for Verification can be added, in this example 20.205.

$$\begin{array}{r}
 00573.24 \text{ m}^3 \\
 (0057)3.240000 \text{ m}^3 \\
 3240.000 \text{ L} \\
 + 20.205 \text{ L} \\
 3260.205 \text{ L}
 \end{array}$$

Note:

- V1HighRes is periodically updated every 10 seconds.

### 12.2.1 Data reading of high-resolution Volume

The register "HighRes" can be data read via ID = 239.

Data reading provides correct measuring unit and measuring value irrespective of meter size.

### 12.3 Verification adapter

During test and verification of SVM S6, where high resolution energy pulses are needed, the verification adapter, type 66-99-275, can be used in the module area of the connection bracket.

The verification adapter gets serial data from SVM S6 every 7. sec. and converts these to high resolution energy pulses with the same resolution as the high resolution display mode. (see chapter 12.1)

The verification adapter must be power supplied on terminal 97-98 from an external 5...30 VDC. The current consumption is max. 5 mA.

The high resolution energy pulses is a open collector signal on terminal 13-12. An additional pull-up resistor on 10 kOhm can be connected via terminal 13A.

#### 12.3.1 Meter types

Verification adapter type 66-99-275 can be used for verification of the below 4 variants of SVM S6, if the correct connection PCB and the correct temperature sensors/simulators and flow simulator is used.

Meter type	S6-A	S6-B	S6-C	S6-D
Connection PCB	5550-492	5550-568	5550-492	5550-732
Sensor type	Pt100, 2-Wire	Pt500, 4- Wire	Pt500, 2- Wire	Pt500, 4- Wire
Volume input	ULTRAFLOW® (11-9-10) or Reed-contact (11-10)			24 V pulses (10B-11B)

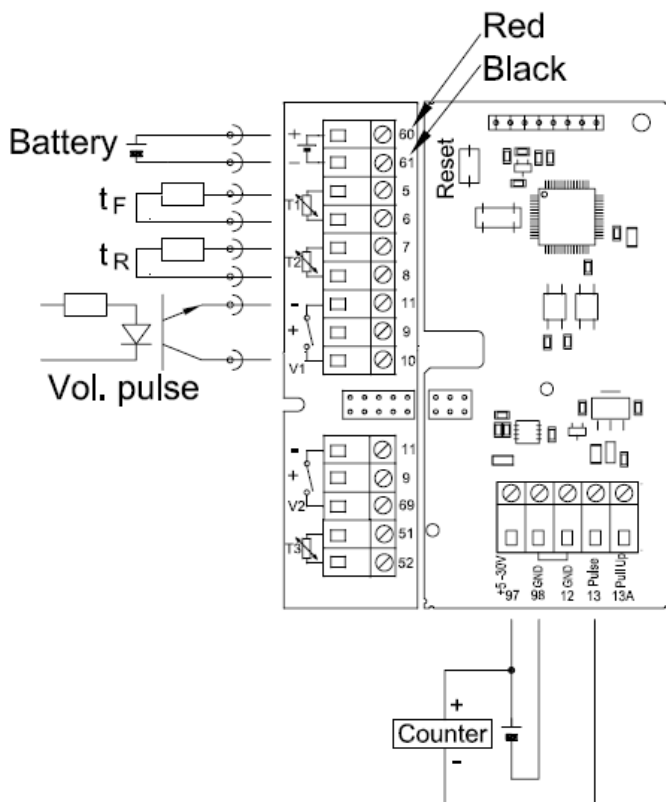

Verificationprint 5550-888 (to the right) with connection PCB 5550-492 (to the left)

**12.3.2 Technical data**

- Power supply (97-98): 5...30 VDC
- Current consumption: Max. 5 mA
- Volume simulation: Max. 128 Hz for CCC=1xx (ULTRAFLOW®)  
Max. 1 Hz for CCC=0xx (Reed-contact)
- HF-energy output (13-12): Open collector, 5...30 VDC max. 15 mA
- Pulse frequency (13-12): Max. 32 kHz as burst per integration
- Data interval: Ca. 7 sec.
- Time-out with no data: Ca. 35 sec.

**12.4 True energy calculation**

During test and verification the energy calculation of the heat meter is compared with the "true energy" calculated according to the formular stated in EN 1434-1:2007 or OIML R75:2002.

The PC program METERTOOL from Kamstrup AB contains an energy calculator suitable for the purpose:

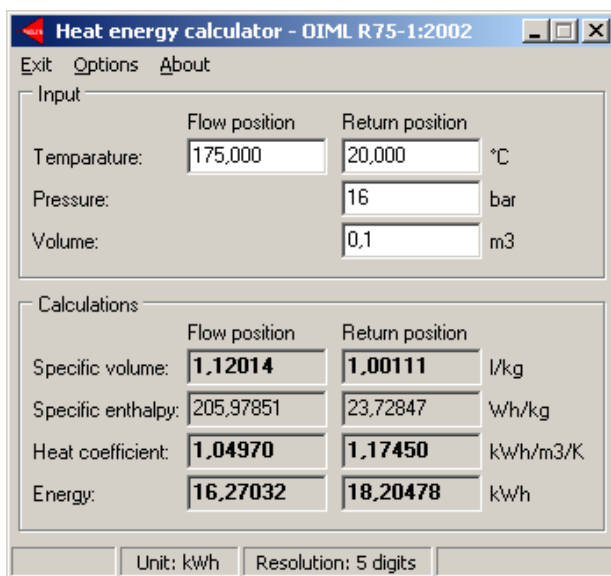

The conventional true energy at the most frequent verification points is stated in below table.

T1 [°C]	T2 [°C]	ΔΘ [K]	Flow [Wh/0.1 m³]	Return flow [Wh/0.1 m³]
42	40	2	230.11	230.29
43	40	3	345.02	345.43
53	50	3	343.62	344.11
50	40	10	1146.70	1151.55
70	50	20	2272.03	2295.86
80	60	20	2261.08	2287.57
160	40	120	12793.12	13988.44
160	20	140	14900.00	16390.83
175	20	155	16270.32	18204.78

## 13 METERTOOL and LogView for SVM S6

### 13.1 Introduction

METERTOOL and LogView for MULTICAL® 602 is also used for SVM S6

”**METERTOOL MULTICAL® 602**” is configuration and verification software for reconfiguration and test/verification of SVM S6 (Item nr. 66-99-718).

”**LogView MULTICAL® 602**” for log data readout as well as interval logging. The read data can be used for analysis and diagnostic test of the heating installation. Data can be presented as table and graphics, tables can be exported direct to ”Windows Office Excell” (Item no. 66-99-719).

#### 13.1.1 System requirements

METERTOOL/LogView requires minimum Windows XP SP3, Windows 7 Home Premium SP1 or newer as well as Windows Internet Explorer 5.01.

<b>Minimum:</b>	1 GB RAM	<b>Recommended:</b>	1 GB RAM
	8 GB free HD space		10 GB free HD space
	Display resolution 1024 X 768		
	USB		
	Printer installed		

Administrator rights to the PC are needed in order to install and use the programs. They must be installed under the user login of the person, who is to use the programs.

#### 13.1.2 Interface

The following interfaces can be used:

Verification equipment	type	66-99-399	Verification of 67-C (2-W/Pt500) and total/partial reconfiguration
Verification equipment	type	66-99-398	Verification of 67-B/D(4-W/Pt500) and total/partial reconfiguration
Verification equipment	type	66-99-397	Verification of 67-A (2-W/Pt100) and total/partial reconfiguration
Programming base	type	S-7590-014	Total/partial reconfiguration
Programming base	type	66-99-360	Configuration/programming hardware for MC602/S6, to be used together with optical eye
Optical eye USB	type	66-99-099	Partial reconfiguration
Optical eye Comport	type	66-99-102	Partial reconfiguration
USB 3-wire	type	66-99-098	Partial reconfiguration via module

Using equipment with Kamstrup USB, the USB driver must be installed before connection.

#### 13.1.3 Installation

Check that system requirements are fulfilled.

Close other open programs before starting the installation.

Insert the CD in the drive and follow the program’s directions through the installation.

If Metertool is downloaded from Kamstrup’s FTP server, the corresponding instructions must be followed.

When the installation is completed, the icon ”**METERTOOL MULTICAL® 602**” and/or ”**LogView MULTICAL® 602**” will appear in the ‘All Programs’ menu under ‘Kamstrup METERTOOL’ or ‘Kamstrup LogView’ (or from the menu ”start” for Windows XP) and as a link on the desktop. Doubleclick on link or icon in order to start the required program.

### 13.2 METERTOOL SVM S6

#### 13.2.1 General information

It is important to be familiar with the calculator’s functions before starting programming.

There are two programming options ”Partial programming” and ”Total programming”.

”Partial programming” does not allow change of coding which is important to energy calculation, e.g. Type number and Program number.

”Total programming” makes it possible also to change the rest of the values. Programming is only possible if the internal programming lock is closed (short circuit pen 66-99-278).

It is not possible to change the series number, as this is a unique number which is allocated to the meter during production.

”V2(CCC)”, ”T1”, ”T2” and ”Max T1 for cooling” can be disabled, depending on the meter type in question.

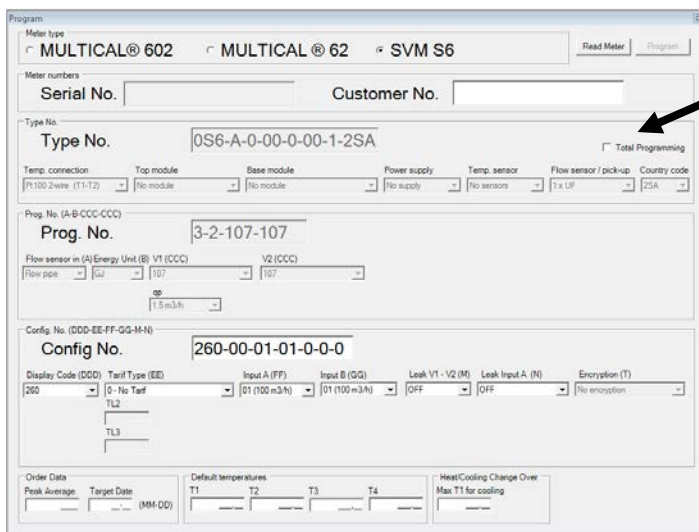

= Partial Programming  
 = Total programming



The program is self-explanatory as to most coding numbers (see text in ”combo-boxes”), further details can be found in the respective paragraphs of the technical description.

#### 13.2.2 Total programming

To do total programming the meter must be connected via an optical eye to a PC with the METERTOOL software running. Break the verification seal and short circuit the TOTAL PROG button on the inside of the calculator top with a short circuit pen (66-99-278).

**Note!** This should only be done by an accredited laboratory, since breaking of the verification seal revokes the legal verification as well as the factory warranty.

After shorting the total programming circuit, the meter is set in programming mode for 4 minutes. As long as METERTOOL is communicating with the meter, the time for programming mode is extended, and after 4 minutes of inactivity the meter will return to normal mode. When the desired values are set, METERTOOL will terminate the programming mode by a reset, and the meter returns to normal mode ready for use.

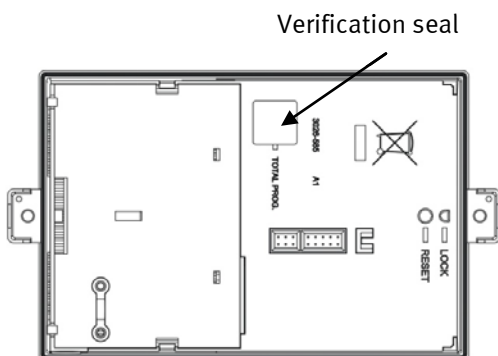

Figure 13

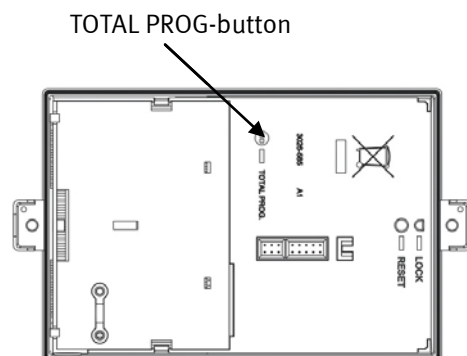

Figure 14

### 13.2.3 File

The menu "File" includes printer setup as well as printout possibility of new meter label or test certificate.

<b>Exit</b>	Close METERTOOL
<b>Certificate</b>	Initiates printout of test certificate
<b>Print Label</b>	Initiates printout of meter label
<b>Select Label Printer</b>	Printer setup

### 13.2.4 Utility

The menu "Utility" includes the following configuration and test points:

<b>Configuration</b>	Overall view which is used during reading and programming (see example at top of page)
<b>Preset VA/VB</b>	Presets the register values of the two extra pulse inputs for water and electricity meters
<b>Time/Date</b>	Transfer of date and time to SVM S6 calculator and top module
<b>Info code setup</b>	Used for disabling/enabling data communication between SVM S6 and ULTRAFLOW® 54
<b>Reset</b>	Normal reset, i.e. reset of data logger and total reset
<b>Meter Type</b>	Reads meter type, software revision and CRC checksum
<b>Verification</b>	See separate paragraph, <b>13.3</b> Verification

"Info code setup" is used for disabling/enabling data communication between SVM S6 and ULTRAFLOW® 14/54.

"Info code setup" is carried out via optical reading head without breaking the meter's verification sealing.

SVM S6 can communicate with ULTRAFLOW® 54 in order to receive error messages from the flow meter. This communication is only supported if SVM S6 and ULTRAFLOW® 54 are direct connected (not via Pulse Transmitter). In case of connection via Pulse Transmitter, or if ULTRAFLOW® 65 is used, the communication must be disabled, otherwise SVM S6 will display the info code for missing communication.

In SVM S6 and ULTRAFLOW® 14 (Cooling meter) communication is supported using Pulse Transmitter 66-99-618.

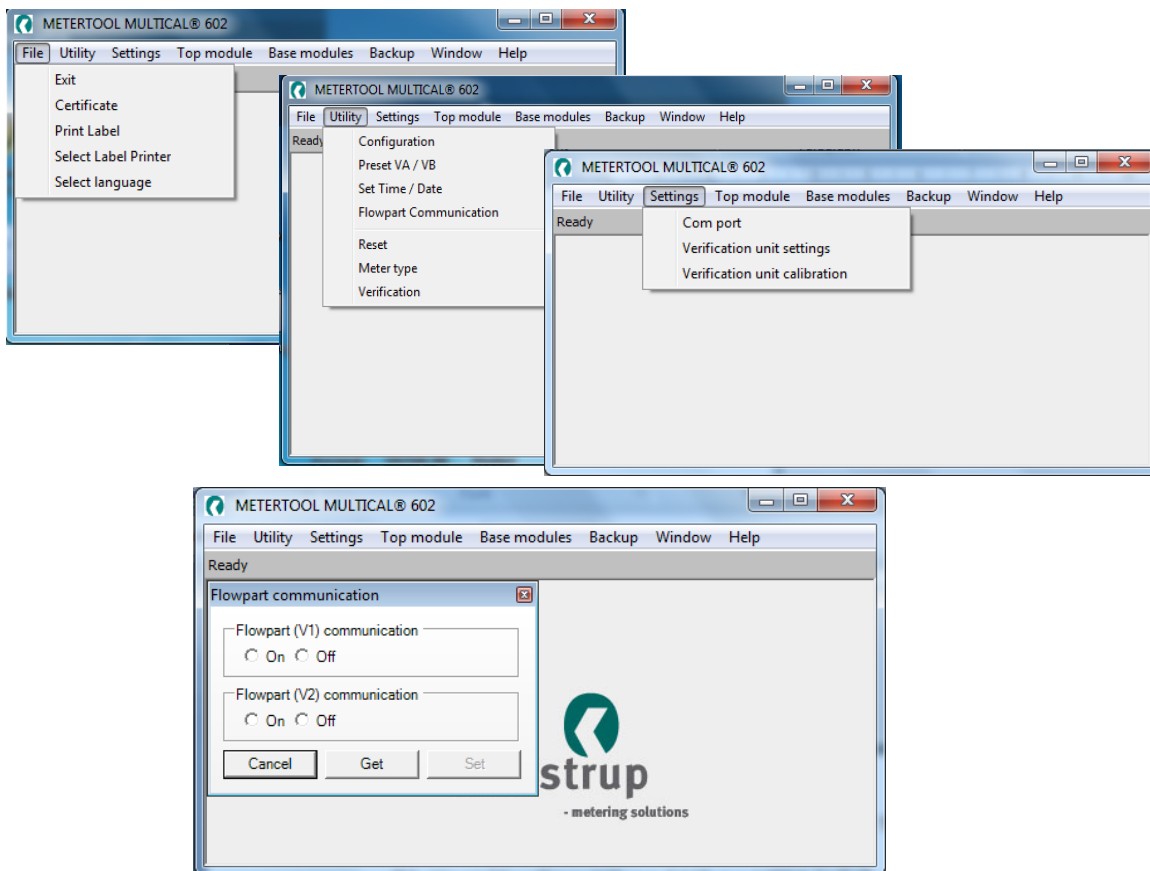

Open "Flowpart communication" and activate "Get" in order to read the meter's setup of communication with flow sensors.

Select the required values for flow sensor 1 and flow sensor 2.

Subsequently, activate "Set" in order to send the change to the meter.

The meter now supports the selected setup.

NOTE! If the meter is subsequently configured, the communication setup is reset to standard setup. The change of communication setup must, therefore, be repeated.

### 13.2.5 Settings

#### Setup

Setup of comport for interface of calculator /equipment.

#### Verification unit settings

Check and update of METERTOOL Program/database.  
Input and maintenance of verification data of connected verification equipment.

See separate paragraph, **13.3 Verification**

**Verification unit calibration** Used for changing between temperature set points during calibration.



**13.2.6 Top modules**

The menu "Top modules" includes identification as well as configuration of the mounted top module.

Top modules and possible configurations are described in paragraph 10.1 Top modules.

**Note!** Top module no. 67-01 cannot be identified, as this module does not include identification which can be read by SVM S6.

**13.2.7 Base modules**

The menu "Bottom modules" is used for the configuration of base module data. See section 10.2 Base modules.

**13.2.8 Backup**

Used for exporting/importing a backup file of saved verification data.

**13.2.9 Windows**

The function makes it possible to change between open dialog boxes of the program.

**13.2.10 Help**

**Output** Opens the communication log, which is used in connection with troubleshooting in the program.

**Contact** Mail address for registration of METERTOOL users, and questions on subjects related to METERTOOL.

**About** Includes program numbers and revisions of the various components of the installed version. In connection with error reports on METERTOOL software we ask you to e-mail us a screen dump of "About".

**User Manual** Opens link to user manuals for METERTOOL- and LogView- programs for Kamstrup heat/cooling-, water- and flow meters.

**13.2.11 Application**

Doubleclick on link or icon in order to start the program.

Activate "Configuration" under "Utility" and select "SVM S6" under "Meter type" in order to start meter configuration.

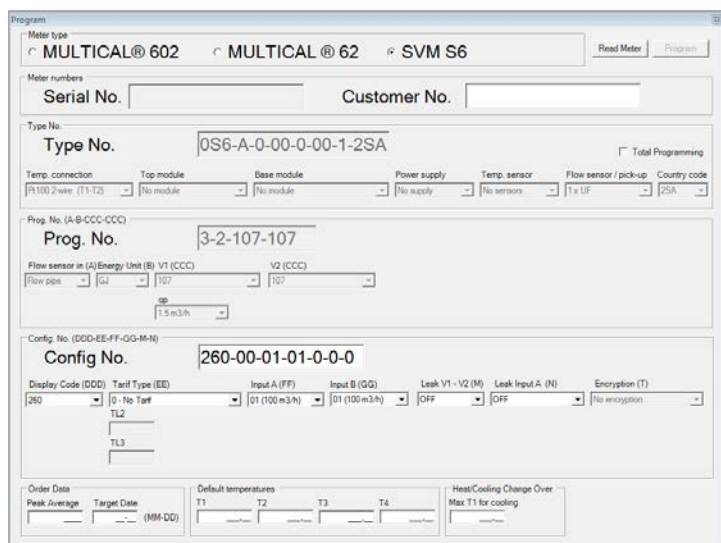

Enter the present configuration by activating "Read meter".

Make the required coding changes and activate "Program" in order to carry out the changes in the meter.

**Note!** Please remember setup of comport the first time the program is used.

### 13.3 Verification

#### 13.3.1 General information

Verification of SVM S6 requires Metertool for MULTICAL® 602, verification equipment as well as import of verification data into the METERTOOL-program.

#### 13.3.2 Verification equipment

Verification equipment, e.g. type 66-99-399, is used for verification of the calculator SVM S6. Verification includes energy verification of "E1" and "E3", test of volume inputs "V1", "V2", "VA" and "VB" as well as test of temperature input "T3".

Different temperatures are simulated for the two sensor inputs, "T1" and "T2", which form the basis of the verification of the energy calculation together with the volume simulation.

The equipment was primarily constructed for use in laboratories, which test and verify heat meters, but can also be used for performance testing the meter.

The computer program "METERTOOL MULTICAL® 602" type 66-99-704 is used for configuration, test and verification.

Verification equipment for SVM S6 includes USB interface (type 66-99-098) as well as corresponding driver software. During installation this interface creates a "Virtual comport" which figures in the computer as an optional comport of the METERTOOL MULTICAL® 602 software. As this "Virtual comport" only exists when the equipment is connected, the verification equipment *must* always be connected to the computer before the program "METERTOOL MULTICAL® 602" is started.

Furthermore, the verification equipment requires mains supply via the included mains adapter.



Verification does not apply to temperature sensors and flow part(s).

The verification equipment is available in three different types, depending on the MULTICAL® 602 type used and the temperature points to be tested.

66-99-397 Standard (EN1434/MID) Type 67-A (2-wire Pt100)	T1 [°C] 160 80 43	T2 [°C] 20 60 40	T3 [°C] 5
66-99-398 Standard (EN1434/MID) Type 67-B/D (4-wire Pt500)	T1 [°C] 160 80 43	T2 [°C] 20 60 40	T3 [°C] -
66-99-399 Standard (EN1434/MID) Type 67-C (2-wire Pt500)	T1 [°C] 160 80 43	T2 [°C] 20 60 40	T3 [°C] 5

For other equipment variants (types or temperature points), please contact Kamstrup A/S.

**13.3.3 Function**

Verification equipment, e.g. type 66-99-399, which is mounted in a standard base, includes battery, verification PCB with connection terminals, microprocessor, control relays and precision resistors.

The calculator can simply be mounted on this base instead of the calculator base.

During test the calculator is supplied by the battery. The verification PCB is powered with 12 VDC by the enclosed external mains adapter. The microprocessor simulates volume based on pulse frequency and the number of pulses per test point selected in the computer program. The temperature simulation is obtained by means of fixed precision resistors, which are automatically changed via relays controlled by the microprocessor.

After test the computer reads all registers of the calculator and compares these values with the calculated values.

The calibration result in percentage of each test point can be stored in the computer under the series number of the tested SVM S6 to be printed out later on a test certificate.

**13.3.4 Verification data**

The first time METERTOOL and the verification equipment is used a number of calibration data must be entered into the menu "Verification" under "Settings" in the program METERTOOL. Calibration data is electronically included in the verification equipment (also enclosed with the verification equipment as a certificate on paper). In order to transfer calibration data from the equipment to the program select "Verification" from the menu "Settings" and activate "Read". Calibration data is now transferred to and saved in the program METERTOOL.

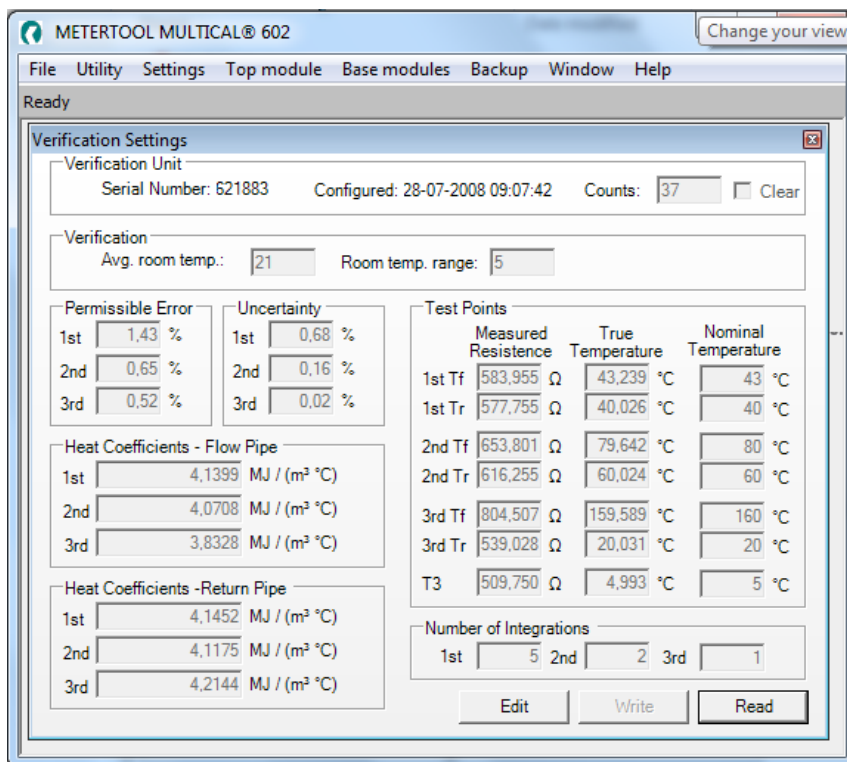

The calibration data of the equipment and the program verification data are compared every time the verification equipment is connected in order to secure that verification data is updated if the calibration data of the equipment have been changed. For instance this can be due to recalibration of verification equipment. Calibration data of the verification equipment can be maintained by changing the verification data in the program METERTOOL and clicking on "Write" this new data into the equipment. In order to avoid unintentional change of calibration data "write" is protected by a password, which can be obtained from Kamstrup A/S.

Calibration data include test points, permissible error, uncertainty, ambient temperature (fixed value) and number of Integrations per test.

Having entered verification data the program automatically calculates the true k-factor in accordance with the formula of EN 1434 and OIML R75:2002.

**13.3.5 Verification**

The verification program menu is opened by activating "Verification" in the menu "Utility".

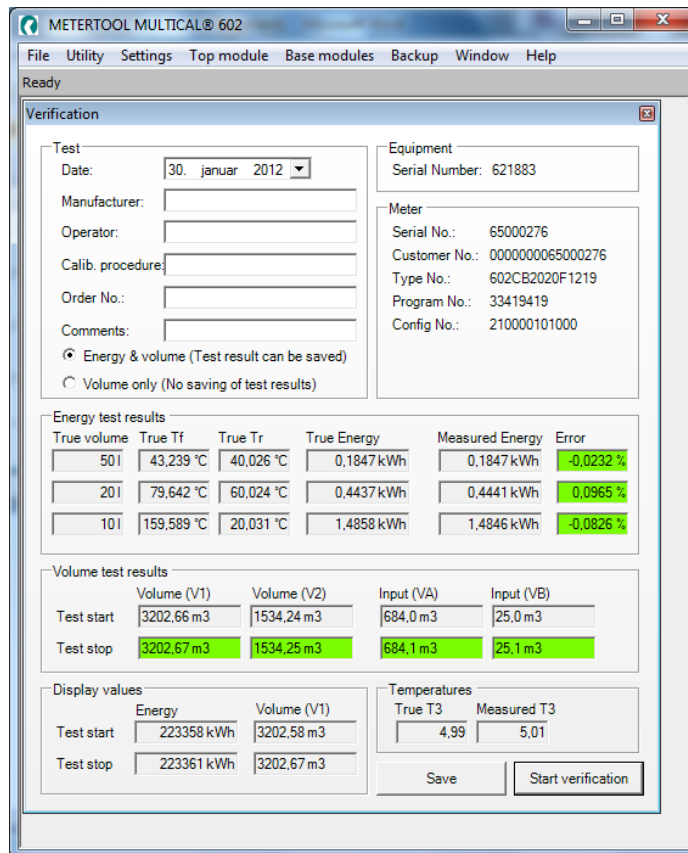

Klick on "Start verification" in order to start test/verification.

When the test has been completed the result will be displayed. If the result can be approved click on "Save". The result is now saved in the database under the series number of the calculator. You can save several results under one series number without overwriting earlier results.

**13.3.6 Certificate**

If you want to print out a certificate with saved results, select "Certificate" in the menu "File". You can now find the test/verification result according to series number, and the certificate can be printed out.

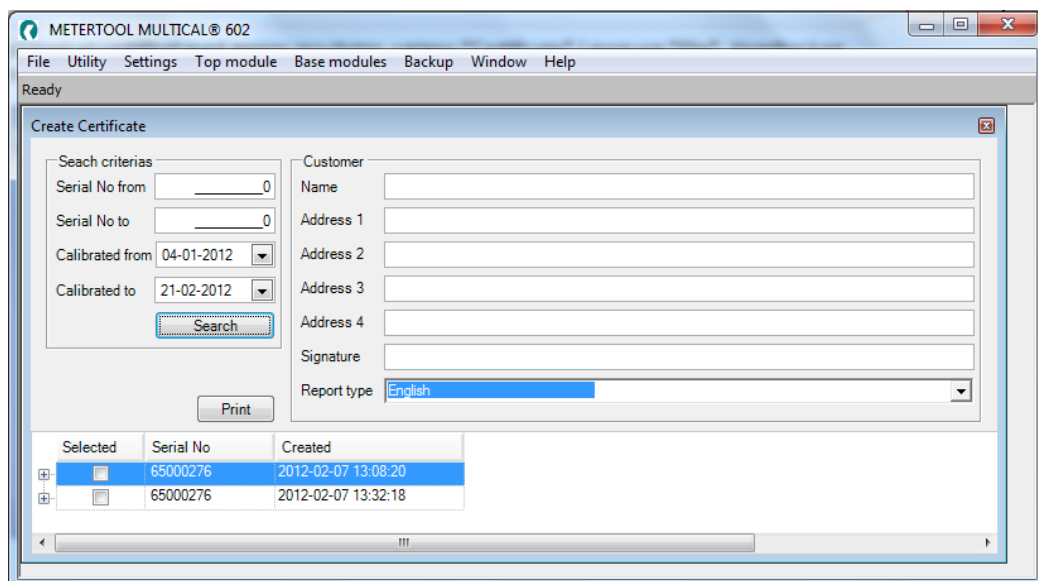

### 13.4 LogView

#### 13.4.1 Introduction and installation

Regarding "Introduction", "Interface" and "Installation" see paragraph 13.1 Introduction METERTOOL.

#### 13.4.2 General information

"LogView MULTICAL® 602" is used for read-out of logging data from SVM S6 calculator and top modules (e.g. hourly data) as well as interval logging. The read out data can be used for analysis and diagnostic test of the heating installation. Data can be presented as table and graphics, tables can be exported to "Windows Office Excel" (ordering no. 66-99-719).

For available logging data see paragraph 6.10 Data loggers.

#### 13.4.3 "File"

**Settings** Setup of comport for interface of calculator/equipment.

**Note!** Please remember that the USB interface must be connected before starting the LogView program.  
Online program update.

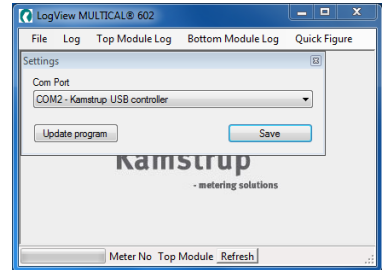

**Exit** Exit LogView

#### 13.4.4 "Log"

Select the required data function.

**Interval Data** allows interval reading of current SVM S6 counts at optional intervals between 1 and 1440 minutes as well as an optional number of repetitions of the reading between 1 and 9999 times.

For read-out of "current" counts, enter interval: 1 and repetition: 1. Thereby you obtain one "instantaneous" reading.

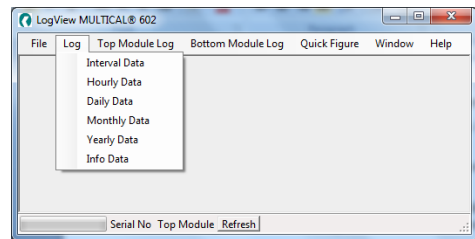

**Daily Data, Monthly Data and Yearly Data** allow read-out of data logged by SVM S6, with optional data period and values.

**Info Data** allows read-out of the latest 50 info events from SVM S6, reading includes date and info code of the info event.

#### 13.4.5 "Top Module Log"

This function makes it possible to read out logging data, which have been logged by and stored in a top module. This will mainly be read-out of e.g. "Hourly Logging Data", for other possibilities see paragraph 10.1.1 Top modules

#### 13.4.6 "Bottom Module Log"

Is used for reading of logger data collected in base modules.

#### 13.4.7 "Quick Figure"

Quick figure reads out the energy register during verification and calculates the related Quick figure.

#### 13.4.8 "Window"

The function makes it possible to change between open dialog boxes in the program.

#### 13.4.9 "Help"

**Contact** Mail address for registration as LogView user as well as for requests on LogView related subjects.

**About** Includes program numbers and revisions of the different components of the installed version.

In connection with error reports on LogView software we ask you to mail us a screen dump of "About".

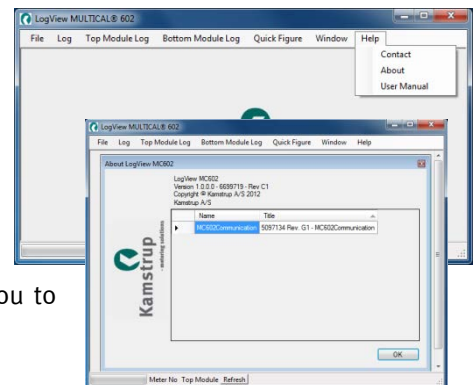

**User Manual** Opens link to user manuals for METERTOOL- and LogView- programs for Kamstrup heat-/cooling-, water- and flow meters.

13.4.10 Application

Doubleclick on link or icon for "LogView MULTICAL® 602" in order to start the program, and select the required data function.

**Note!** Remember to set up the comport the first time the program is used.

"Daily Data" is used as an example:

Choice of data period From/To :

Activate "Start" to collect required data from the meter:

Calculation with read values:

Graph/table of calculation:

Possible / saved calculations:

Choice of required data registers:

Graph(s)/table of data from selected registers:

After read-out nonselected data registers are toned grey and cannot be used during further processing/analysis. To read out all data, activate "Select All" to select all values.

When read-out has been completed the program automatically asks whether the data should be saved. We recommend you to save the read-outs, securing that data can be reopened later for further analysis or documentation.

Additional functions can now be selected for the read data. By means of "Calculation" individual calculations can be carried out, and graphs/tables with the values appear by activating "Show Graph". If you want to save calculation forms for reuse, select "Add to" and the function is added to "Calculated Registers".

In order to carry out a new data read-out, click on "Clear", and select new period and new data registers.

Choosing "Selected Registers" under "Graphs" graph(s)/table with the marked registers are displayed.

Tables can be exported direct to "Windows Office Excel" or printed.

To zoom in activate (+), to zoom out activate (-) on the axes.

The arrows (↑↓←→) on the axes are used for manoeuvring in the graph area.

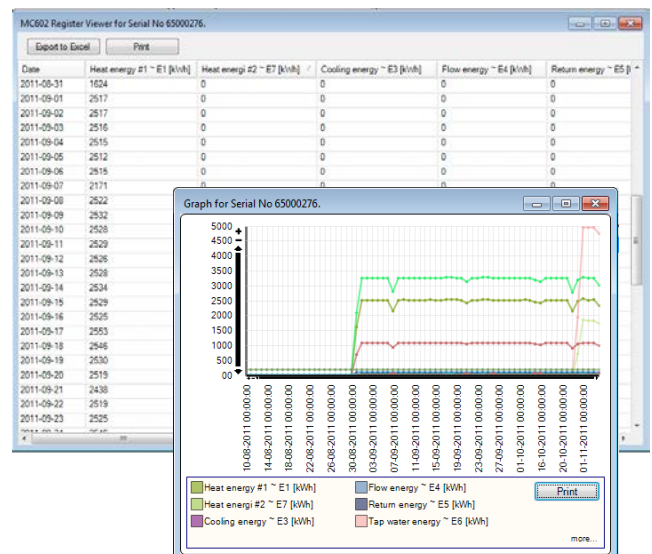

## 14 Approvals

### 14.1 CE marking

SVM S6 is CE-marked in accordance with following directives:

EMC directive      2004/108/EC

LV directive        2006/95/EC

### 14.2 Measuring instrument directive

SVM S6 is available with CE-marking according to MID (2004/22/EC). The certificates have the following numbers:

B-Module:    DK-0200-MI004-020

D-Module:    DK-0200-MIQA-001



**Declaration of Conformity**

**Overensstemmelseserklæring  
Déclaration de conformité  
Konformitätserklärung  
Deklaracja Zgodności  
Declaración de conformidad  
Declaratie de conformitate**

**We  
Vi  
Nous  
Wir  
My  
Nosotros  
Noi**

**Kamstrup A/S  
Industrivej 28, Stilling  
DK-8660 Skanderborg  
Denmark  
Tel: +45 89 93 10 00**

declare under our sole responsibility that the product(s):  
erklærer under eneansvar, at produkt(erne):  
déclarons sous notre responsabilité que le/les produit(s):  
erklären in alleiniger Verantwortung, dass/die Produkt(e):  
deklarujemy z pełną odpowiedzialnością że produkt(y):  
Declaramos, bajo responsabilidad propia que el/los producto  
declaram pe proprie raspundere ca produsul/produsele:

Instrument	Type	Type No.:	Classes	Type Approval Ref.:
Heat Meter	MULTICAL® 401	66-V and 66-W	Cl 2/3, M1, E1	DK-0200-MI004-001
Heat Meter	MULTICAL® 402	402-V, 402-W, 402-T	Cl 2/3, M1, E1	DK-0200-MI004-013
Temperature Sensors	PL and DS	65-00-0A/B/C/D 66-00-0F/G 65-00-0L/M/N/P 66-00-0Q3/4 65-56-4	M1	DK-0200-MI004-002
Flow Sensor	ULTRAFLOW® qp 0.6...400 m³/h	65-S/R/T	Cl 3, M1, E1	DK-0200-MI004-003
Flow Sensor	ULTRAFLOW® qp 0.6...40 m³/h and qp 150...400 m³/h	65-S/R/T	Cl 2/3, M1, E1	DK-0200-MI004-003
Calculator	MULTICAL® 601 MULTICAL® 601+ MULTICAL® 602 SVM S6 MULTICAL® 801	67-A/B/C/D 67-E 602-A/B/C/D S6-A/B/C/D 67-F/G/K/L	M1, E1/E2 M1, E1/E2 M1, E1/E2 M1, E1/E2 M1, E1/E2	DK-0200-MI004-004 DK-0200-MI004-004 DK-0200-MI004-020 DK-0200-MI004-020 DK-0200-MI004-009
Flow Sensor	ULTRAFLOW® 54/34 qp 0.6...100 m³/h qp 150...1000 m³/h	65-5/65-3	Cl 2/3 M1, E1/E2 M1/M2, E1/E2	DK-0200-MI004-008
Water Meter	MULTICAL® 21 MULTICAL® 41 MULTICAL® 61 MULTICAL® 62 flowIQ™ 3100	021 66-Z 67-Z 62-Z 031	Cl 2, M1, E1/E2 Cl 2, M1, E1 Cl 2, M1, E1, B Cl 2, M1, E1, B Cl 2, M1, E1/E2	DK-0200-MI001-015 DK-0200-MI001-003 DK-0200-MI001-010 DK-0200-MI001-016 DK-0200-MI001-017

are in conformity with the requirements of the following directives:

er i overensstemmelse med kravene i følgende direktiver:

sont conforme(s) aux exigences de la/des directives:

mit den Anforderungen der Richtlinie(n) konform ist/sind:

są zgodne z wymaganiami następujących dyrektyw:

es/son conformes con los requerimientos de las siguientes directivas:

este/sunt in conformitate cu cerintele urmatoarelor directive:

Measuring Instrument Directive 2004/22/EC  
EMC Directive 2004/108/EC  
LVD Directive 2006/95/EC  
PE-Directive (Pressure) 97/23/EC  
R&TTE 1999/5/EC

**Date: 2013-09-03**

Notified Body, Module D Certificate:

Force Certification A/S  
EC Notified Body nr. 0200  
Park Alle 345, 2605 Brøndby  
Denmark

**Sign.:**

**Lars Bo Hammer  
Quality Assurance Manager**

5518-050, Rev.: W1, Kamstrup A/S, DK8660 Skanderborg, Denmark

## 15 Trouble-shooting

SVM S6 is constructed with a view to fast and simple mounting as well as long-term, reliable operation at the heat consumer's.

Should you, however, experience an operating problem with the meter, the error detection table below may help you clarify the possible reason.

In connection with repair, if necessary, we recommend to replace only battery and temperature sensors and communication modules. Alternatively, the entire meter must be replaced.

Major repairs must be made in our factory.

Before sending in the meter for repair, you must go through below error detection table to help clarify the possible cause of the problem.

Symptom	Possible cause	Suggested corrections
No display function (blank display)	No power supply.	Replace the battery or check the mains supply. Is there 3.6 VDC on terminal 60(+) and 61(-) ?
No accumulation of energy (e.g. MWh) and volume (m <sup>3</sup> )	Read "info" on the display.	Check the error indicated by the info code (see section 6.8)
	If "info" = 000, 16384 or 32768 ⇒	Check that the flow direction corresponds with the arrow on the flow sensor
	If "info" = 004, 008 or 012 ⇒	Check the temperature sensors. If defects are detected, replace the sensor set.
	If "info" = 4096 or 8192 ⇒	There is air in the installation. Ventilation necessary.
Accumulation of volume (m <sup>3</sup> ), but not of energy (e.g. MWh)	Flow and return sensors have been reversed, either during installation or connection.	Mount the sensors correctly
No accumulation of volume (m <sup>3</sup> )	No volume pulses	Check that the flow direction corresponds with the arrow on the flow sensor. Check the flow sensor connection
Incorrect accumulation of volume (m <sup>3</sup> )	Incorrect programming. If "info" = 128 or 2048 ⇒	Check if the pulse figure on the flow sensor corresponds with the calculator
Incorrect temperature indication	Defective temperature sensor Insufficient installation	Replace the sensor set. Check the installation
Temperature display is too low or accumulated energy is too little (e.g. MWh)	Poor thermal sensor contact Heat dissipation Sensor pockets too short	Place the sensors in the bottom of the sensor pockets. Insulate the sensor pockets. Replace sensor pockets with longer ones.

## 16 Disposal

Kamstrup A/S is environmentally certified according to ISO 14001, and as far as possible and as part of our environmental policy we use materials that can be recycled in an environmentally correct way.

Kamstrup A/S has calculated carbon footprint of all meters.



As of August 2005 heat meters from Kamstrup are marked according to the EU directive 2002/96/EEA and the standard EN 50419.

The purpose of marking is to inform that the heat meter cannot be disposed of as ordinary waste.

- **Disposal by Kamstrup A/S**

Kamstrup accepts worn-out meters for environmentally correct disposal according to previous agreement. The disposal is free of charge to the customer, except for the cost of transportation to Kamstrup A/S.

- **The customer sends for disposal**

The meters must not be disassembled prior to dispatch. The complete meter is handed in for approved national/local disposal. Enclose a copy of this chapter in order to inform the recipient of the contents.

Please note that lithium cells, and meters containing lithium cells must be shipped as dangerous goods. Please see Kamstrup document 5509-682 “Shipping of battery powered heat meters and lithium batteries”

Subject	Material	Recommended destruction
Lithium cells in SVM S6	Lithium and Thionylchlorid >UN 3090< D-cell: 4.9 g lithium	Approved destruction of lithium cells
PC boards in SVM S6 (LC-display must be removed)	Copper epoxide laminate with soldered componenets	Print board scrap for concentration of noble metals
LC-display	Glass and liquid crystals	Approved processing of LC displays
Cables for flow sensor and sensors	Copper with silicone mantle	Cable recycling
Transparent top cover	PC	Plastic recycling
Print box and base unit	Noryl and ABS with TPE gaskets	Plastic recycling
Other plastic parts, cast	PC + 20% glass	Plastic recycling
Meter case, ULTRAFLOW®	> 84% alpha brass/redbrass < 15% standard steel (St 37) < 1% stainless steel	Metal recycling
Packing	Environmental cardboard	Cardboard recycling (Resy)
Packing	Polystyrene	EPS recycling

Please direct any questions you may have concerning environmental matters to:

**Kamstrup AB**  
 Enhagsslingan 2  
 187 40 Täby  
 Fax: + 46 8 522 265 08  
[info@kamstrup.se](mailto:info@kamstrup.se)

## 17 Documents S6

	Swedish	English
Technical description	5512-982	5512-1078
Data sheet	5810-1141	5810-1142
Installation and user guide	5512-1102	5512-1103

