

MULTICAL® 61

DATA SHEET

- Ultrasonic flow sensor
- No wear and long lifetime
- Exceptionally accurate $\pm 2\%$
- Static meter, no moving parts
- Flow range 1.6...40 m³/h
- 24 VAC and 230 VAC or 12 years' battery operation
- Room for two extra modules at a time
- Optional leak surveillance
- MID type approval (OIML R 49)
- Approved for drinking water (DK, DE, UK and FR)

MID-2004/22/EC

CE M11 0200



Application

MULTICAL® 61 is used for measurement of cold water consumption (0.1...50°C) and hot water consumption (0.1...90°C) in trade, industry and domestic use.

The meter is very simple to install, read and verify. Furthermore, the unique combination in MULTICAL® 61 of exceptional measuring accuracy and long lifetime means absolutely minimum yearly operating costs.

Flow is measured with ultrasound according to the transit time method, and all measurements, references, readings and calculations are controlled by a microprocessor in the calcu-

lator top, which is an integral part of the calculator. The flow sensor is thus uninfluenced by high humidity.

MULTICAL® 61 can be fitted with two independent modules at a time, a top module with clock backup, pulse output or M-Bus, and a base module with M-Bus, radio, LonWorks or 0/4...20 mA output.

The base module also includes two extra pulse inputs for connection of electricity and water meters. This means that the utility can read the consumption by one automatic data reading.

The meter provides the possibility of leak surveillance. MULTICAL® 61 can monitor the water consumption. Possible running cisterns, leaky heating spirals of tap water tanks or other untightnesses can result in water flow being registered from the water meter 24 hours a day leaving an info-code in the display.

The flow sensor is connected with the calculator base by means of 2.5 m screened cable. If greater distance is needed – up to 10 metres – between flow sensor and calculator a Pulse Transmitter can be used.



Kamstrup

MULTICAL[®] 61

DATA SHEET



Contents

Description	3
Approved meter data	4
Technical data	4
Accuracy	6
Material	7
Flow meter types	8
Ordering details	9
Accessories	10
Leak surveillance	11
Programming	11
Dimensioned sketches	11
Pressure loss	14
Installation angle for ULTRAFLOW [®] 24	15
Straight inlet	15
Installation example	16

MULTICAL® 61

DATA SHEET



Description

MULTICAL® 61 is used for measurement of cold water consumption (0.1...50°C) and hot water consumption (0.1...90°C) and consists of the flow sensor ULTRAFLOW® 24 and the calculator MULTICAL® 601.

MULTICAL® 61 is a static water meter based on the ultrasonic principle. The water meter is based on our experience since 1991 with the development and production of static ultrasonic meters.

The meter has been subjected to a very comprehensive OIML R 49 type test with a view to securing a long-term stable, accurate and reliable meter. One of the water meter's many advantages is the fact that it has no wearing parts, which prolongs its lifetime considerably. Furthermore, the meter has a low starting flow (from only 3 l/h) providing accurate measurement also at low flows.

According to OIML R 49 MULTICAL® 61 can be described as a "complete water meter". In practice this means that flow sensor and calculator must not be separated. If flow sensor and calculator have been separated and the seals have thus been broken, the meter will no longer be valid for billing purposes. Furthermore, the factory guarantee no longer applies.

MULTICAL® 61 is based on ultrasonic measuring and microprocessor technique. All circuits for calculation of flow metering are placed in the calculator base. The flow sensor is without electronics in order to protect it against condensation.

The flow is measured using bidirectional ultrasonic technique based on the transit time method, proven a long-term stable and accurate measuring principle. Two ultrasonic transducers are used to send the sound signal both against and with the flow. The ultrasonic signal travelling with the flow reaches the opposite transducer first. The time difference between the two signals can be converted into flow velocity and thereby also volume.

The accumulated water consumption is displayed with seven significant digits and measuring unit. The display has been specially designed to obtain long lifetime and sharp contrast in a wide temperature range.

Other reading options are operating hour counter, current flow, max. and min. flow, information code, customer number and segment test etc. – depending on configuration.

All registers are saved daily in an EEPROM for 460 days. Furthermore, monthly data for the latest three years and yearly data for the latest 15 years are saved.

MULTICAL® 61 is powered by an internal lithium battery with up to 12 years' lifetime. Alternatively the meter can be mains supplied, either by 24 VAC or 230 VAC.

MULTICAL® 61 can be fitted with plug-in modules in both calculator top (top modules) and in connecting base (base modules). Thus, the meter can be adapted to many different applications and data readings.

In addition to the water meter's own data, MULTICAL® 61 has two extra pulse inputs, VA and VB, for collection and remote accumulation of pulses from e.g. water meters and electricity meters. The pulse inputs are placed in the base modules. Pulse inputs VA and VB function independently of the other inputs/ outputs.

MULTICAL® 61 includes data communication ports. The optical eye on the calculator front enables reading of consumption data and data logger as well as serial PC connection for configuration of the water meter. External communication units can be connected via plug-in modules. MULTICAL® 61 is available with communication modules for e.g. radio, M-Bus, LON, 0/4..20 mA and RS232.

MULTICAL® 61

DATA SHEET



Approved meter data

Approval	DK-0200-MI001-010
Standard	
– OIML R 49-1(2006), OIML R 49-2(2006)	
– WELMEC guide 8.11 (Issue 1, 2006)	
EU-directives	
– MID (Measuring Instrument Directive 2004/22/EC, MI-001)	
– LVD (Low Voltage Directive 2006/95/EC)	
– EMC (Electromagnetic Compatibility Directive 2004/108/EC)	
– PED (Pressure Equipment Directive 97/23/EC) Category 1 (DN50 – DN80)	
MID classifications	
– mechanical environment	Class M1
– electromagnetic environment	Class E1
Climatic class	5...55°C, non-condensing, closed location (indoor installation)
OIML R 49 type designation	Accuracy class 2
Environmental class	Fulfils OIML R 49 class B
Temperature of medium in flow sensor	
– cold water meter	0.1...50°C
– hot water meter	0.1...90°C
Flow meter type	ULTRAFLOW® 24
Hygienic approval	VA (Danish approval) DVGW - W421 (KTW + W270) (German approval) – cold water up to 50°C – hot water up to 85°C WRAS (English approval) – water up to 70°C ACS (French approval)

Technical data

Electrical data	
Supply voltage	3.6 V ± 5%
Battery	3.65 VDC, D-cell lithium
Replacement interval	12 years @ $t_{BAT} < 30^{\circ}C$
Mains supply	230 VAC +15/-30%, 50/60 Hz 24 VAC ±50%, 50/60 Hz
Power consumption mains supply	< 1 W
Backup mains supply	Integral super-cap eliminates interruptions due to short-term power-cuts
EMC data	Fulfils OIML R 49 class E1

MULTICAL® 61

DATA SHEET



Technical data

Pulse inputs VA and VB VA: 65-66 and VB: 67-68	Water meter connection FF(VA) and GG(VB) = 01-40	Electricity meter connection FF(VA) and GG(VB) = 50-60
Pulse input	680 kΩ pull-up to 3.6 V	680 kΩ pull-up to 3.6 V
Pulse ON	< 0.4 V for > 0.1 sec.	< 0.4 V for > 0.1 sec.
Pulse OFF	> 2.5 V for > 0.1 sec.	> 2.5 V for > 0.1 sec.
Pulse frequency	< 1 Hz	< 3 Hz
Electrical isolation	No	No
Max. cable length	25 m	25 m

Pulse outputs CE and CV – via top module 67-08	
Type	Open collector (OB)
Pulse length	Optionally 32 msec. or 100 msec.
External voltage	5-30 VDC
Current	1-10 mA
Residual voltage	$U_{CE} \approx 1 \text{ V}$ at 10 mA
Electrical isolation	2 kV
Max. cable length	25 m

Technical data

Mechanical data

Metrological class	2
Environmental class	Fulfils OIML R 49 class B
Mechanical environment	MID class M1
Electromagnetic environmental class	Fulfils OIML R 49 class E1
Ambient temperature	5...55°C, non-condensing, closed location (indoor installation)
Protection class	Calculator IP54 Flow sensor IP65
Temperature of medium	
– cold water meter	0.1...50°C
– hot water meter	0.1...90°C
Storage temperature	-25...60°C (drained flow sensor)
Pressure stage	
– thread mounted meter	PN16
– flange mounted meter	PN25
Flow meter cable	2.5 m

MULTICAL[®] 61

DATA SHEET



Accuracy

MPE according to OIML R 49

Meter approved T50 (0.1...50°C) and T90 (0.1...90°C)

MPE (maximum permissible error)

For $0.1^{\circ}\text{C} < t \leq 30^{\circ}\text{C}$

$\pm 5\%$ in range $Q_1 \leq Q < Q_2$

$\pm 2\%$ in range $Q_2 \leq Q \leq Q_4$

For $30^{\circ}\text{C} < t \leq 50^{\circ}\text{C}$

$\pm 3\%$ in range $Q_2 \leq Q \leq Q_4$

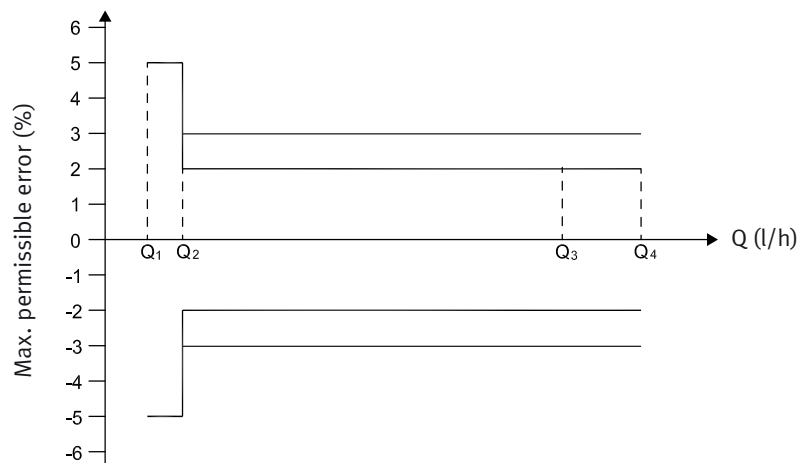

Q₁: Minimum Flowrate

The lowest flowrate at which the water meter provides indications that satisfy the requirements concerning the maximum permissible errors (MPEs.).

Q₂: Transitional Flowrate

The transitional flowrate is the flowrate value occurring between the permanent and minimum flowrates, at which the flowrate range is divided into two zones, the 'upper zone' and the 'lower zone'. Each zone has a characteristic MPE.

Q₃: Permanent Flowrate

The highest flowrate at which the water meter operates in a satisfactory manner under normal conditions of use, i.e. under steady or intermittent flow conditions.

Q₄: Overload Flowrate

The overload flowrate is the highest flowrate at which the meter operates in a satisfactory manner for a short period of time without deteriorating.

MULTICAL[®] 61

DATA SHEET



Material

Wetted parts

Housing, gland	DZR brass (dezincification resistant)
Housing, flange	Stainless steel 1.4408
Transducer	Stainless steel 1.4401
Gaskets	EPDM
Measuring pipe	Thermoplastic, PES 30% GF
Reflectors, mirrors	Thermoplastic, PES 30% GF and stainless steel 1.4305, 1.4306, 1.4401

Flow sensor housing

Base	Thermoplastic, PBT 30% GF
Cover	Thermoplastic, PC 20% GF
Wall bracket	Thermoplastic, PC 20% GF

Calculator housing

Top	Thermoplastic, PC
Base	Thermoplastic, ABS with TPE gaskets (thermoplastic elastomer)
Internal cover	Thermoplastic, ABS

Flow meter cable

Silicone cable with inner teflon insulation.

MULTICAL® 61

DATA SHEET



Ordering details

MULTICAL® 61	Type 67- Z	<input type="checkbox"/>	<input type="checkbox"/>	<input type="checkbox"/>	0	1	<input type="checkbox"/>	<input type="checkbox"/>	<input type="checkbox"/>
Top module									
No module		0							
RTC (Real Time Clock)		1							
RTC + data output + hourly data logger		5							
RTC + M-Bus		7							
RTC + pulse output for CV + hourly data logger		8							
RTC + pulse output for CV + prog. data logger		B							
Base module									
Data + pulse input					10				
M-Bus + pulse inputs					20				
RadioRouter + pulse inputs					21				
Prog. data logger + RTC + 4...20 mA inputs + pulse inputs					22				
0/4...20 mA outputs					23				
LonWorks, FTT-10 A + pulse inputs					24				
Radio + pulse inputs (internal antenna)					25				
Radio + pulse inputs (connection for external antenna)					26				
M-Bus module with MC-III data package + pulse inputs					29				
Wireless M-Bus Mode C1 + pulse inputs					30				
ZigBee 2.4 GHz int.ant. + pulse inputs					60				
Metasys N2 (RS485) + pulse inputs					62				
Supply									
No supply					0				
Battery, D-cell					2				
230 VAC supply module with transformer					7				
24 VAC supply module with transformer					8				
Flow sensor/pick-up unit									
Supplied with one ULTRAFLOW® 24								1	
Meter type									
Hot water meter (0.1...90°C)									7
Cold water meter (0.1...50°C)									8
Country code (language on label etc.)									XX

MULTICAL[®] 61

DATA SHEET



ULTRAFLOW[®] 24 flow meter types

Type number	Nom. Flow Q_3 [m ³ /h]	Max. Flow Q_4 [m ³ /h]	Min. Flow Q_1 [l/h]	Min. cut off [l/h]	Pressure loss $\Delta p @ Q_3$ [bar]	Connection on meter	Length [mm]	Anti- pollution check valve ¹⁾	Strainer ¹⁾
65-2-CDAA-XXX	1.6	2.0	16	3	0.25	G ³ / ₄ B (R ¹ / ₂)	110	-	-
65-2 -CDA1-XXX	1.6	2.0	16	3	0.25	G1B (R ³ / ₄)	110	-	-
65-2-CDAC-XXX ²⁾	1.6	2.0	16	3	0.25	G ³ / ₄ B (R ¹ / ₂)	165	OK	OK
65-2-CDAF-XXX	1.6	2.0	16	3	0.25	G1B (R ³ / ₄)	190	OK	OK
65-2-CEAF-XXX	2.5	3.1	25	6	0.04	G1B (R ³ / ₄)	190	OK	OK
65-2-CGAG-XXX	4.0	5.0	40	7	0.09	G1 ¹ / ₄ B (R1)	260	OK	OK
65-2-CHAG-XXX	6.3	7.9	63	12	0.22	G1 ¹ / ₄ B (R1)	260	OK	OK
65-2-CJAJ-XXX	10	12.5	100	20	0.06	G2B (R1 ¹ / ₂)	300	OK	OK
65-2-CKCE-XXX	16	20	160	30	0.16	DN50	270	-	-
65-2-CLCG-XXX	25	31.3	250	50	0.06	DN65	300	-	-
65-2-CMCH-XXX	40	50	400	80	0.05	DN80	300	-	-

¹⁾ Back-flow protection and strainer must only be used in cold water meters.

²⁾ MULTICAL[®] 61 with flow sensor type 65-2-CDAC (G³/₄B x 165) is only available as cold water meter.

Max. pressure loss according to OIML49 between Q_1 up to and incl. Q_3 must not exceed 0.063 MPa (0.63 bar), at Q_4 max. 0.1 MPa (1 bar).

The type number of the flow sensor cannot be changed after factory programming.

The delivery code can also be used for:

- language and approval on type label
- marking of PN class

Customer labels (2001-XXX) are integrated in the front label.



Accessories

Glands, incl. gaskets

6561-326	Gland incl. gasket for DN15, (R $\frac{1}{2}$ x G $\frac{3}{4}$), (two pcs.)
6561-327	Gland incl. gasket for DN20, (R $\frac{3}{4}$ x G1), (two pcs.)
6561-328	Gland incl. gasket for DN25, (R1 x G $\frac{5}{4}$), (one pc.)
6561-329	Gland incl. gasket for DN40, (R $\frac{1}{2}$ x G2), (one pc.)

Gaskets

Gasket for gland:

3130-251	G $\frac{3}{4}$ (R $\frac{1}{2}$) (two pcs.)
3130-252	G1 (R $\frac{3}{4}$) (two pcs.)
3130-253	G $\frac{1}{4}$ (R1) (two pcs.)
3130-254	G2 (R $\frac{1}{2}$) (two pcs.)

Gasket for flange:

2210-099	DN50 (one pc.)
2210-141	DN65 (one pc.)
2210-140	DN80 (one pc.)

Strainer for flow sensor inlet¹⁾

6556-484	Strainer DN15 for G $\frac{3}{4}$ B (R $\frac{1}{2}$) (10 pcs.), not for 110 mm housing
6556-485	Strainer DN20 for G1B (R $\frac{3}{4}$) (10 pcs.)
2210-192	Strainer DN25 for G $\frac{1}{4}$ B (R1) (one pc.)
2210-193	Strainer DN40 for G2B (R $\frac{1}{2}$) (one pc.)

Anti-pollution check valve (EN 13959) for flow sensor return, incl. PE gasket (PE = Polyethylene)¹⁾

6556-480	Anti-pollution check valve DN15 for G $\frac{3}{4}$ B, incl. strainer and two PE gaskets, not for 110 mm housing
6556-481	Anti-pollution check valve DN20 for G1B, incl. strainer and two PE gaskets
6556-482	Anti-pollution check valve DN25 for G $\frac{5}{4}$ B, incl. PE gasket
6556-483	Anti-pollution check valve DN40 for G2B, incl. PE gasket

PE gasket for strainer and anti-pollution check valve¹⁾

6556-494	DN15 (10 pcs.)
6556-495	DN20 (10 pcs.)
6556-496	DN25 (10 pcs.)
6556-497	DN40 (10 pcs.)

Pulse Transmitter (Cable extension set)

6699-618.0	Pulse Transmitter without cable
6699-618.2	Pulse Transmitter incl. 10 m cable

¹⁾ Back-flow protection, strainer (filter) and PE-gaskets must only be used in cold water meters.

MULTICAL® 61

DATA SHEET



Leak surveillance

MULTICAL® 61 can monitor the water consumption. Possible running cisterns, leaky heating spirals of tap water tanks or other untightnesses can result in water flow being registered from the water meter 24 hours a day.

If MULTICAL® 61 does not register e.g. at least one continuous hour/day without water flow from the water meter, this implies a leakage in the water system and an alarm will be sent via remote communication.

When the meter has registered a leak, an alarm message can be sent to a receiving station, where incoming alarms are processed according to an encoded action pattern determined for each customer, e.g. starting with an SMS message to the customer's mobile phone parallel with the water station on guard receiving the message. Regular data readings from MULTICAL® 61 to receiving station/control centre ensure that defective remote readings, if any, are detected.

Programming

MULTICAL® 61 can be ordered in combinations as required by the customer.

The supplied meter is configured from the factory and ready for use, but can also be changed/reconfigured after installation.

However, this does not apply to the meter's legal parameters (type number and CCC-code) which cannot be changed unless the verification seal is broken. This requires that changes must be made in an accredited meter laboratory.

The CCC-code states the calculator's adaption to a specific flow sensor type to the effect that calculating speed and display resolution are optimized for the selected flow sensor at the same time as type approval regulations about minimum resolution and maximum register overflow are obeyed.

Dimensioned sketches

MULTICAL® 61

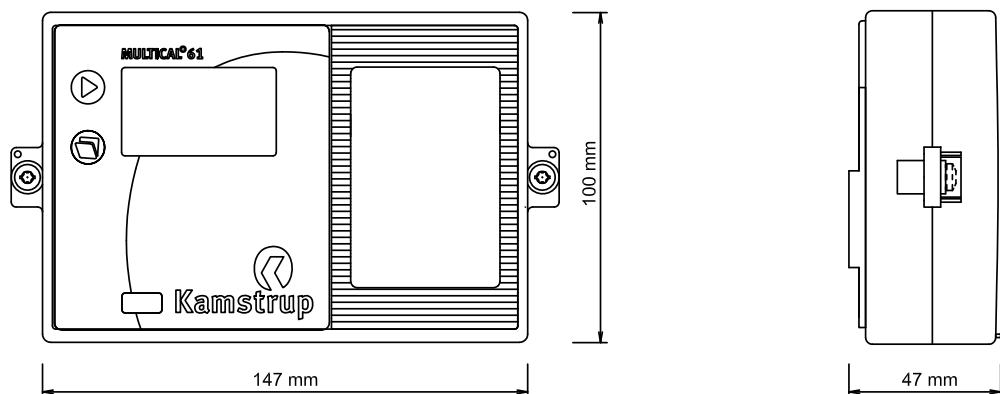

MULTICAL[®] 61

DATA SHEET



Dimensioned sketches

ULTRAFLOW[®] 24, G³/₄B and G1B

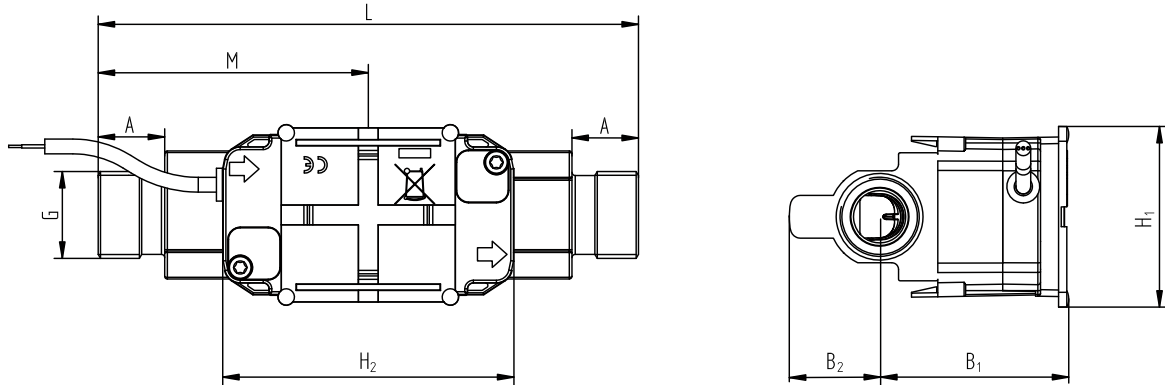

Thread ISO 228-1

Thread	L [mm]	M [mm]	H ₂ [mm]	A [mm]	B ₁ [mm]	B ₂ [mm]	H ₁ [mm]	App. weight [kg]
G ³ / ₄ B (Q ₃ =1.6 m ³ /h)	110	L/2	89	10.5	58	36	55	0.8
G ³ / ₄ B (Q ₃ =1.6 m ³ /h)	165	L/2	89	20.5	58	29	55	1.2
G1B (Q ₃ =1.6 m ³ /h)	110	L/2	89	10.5	58	28	55	0.9
G1B (Q ₃ =1.6 m ³ /h)	190	L/2	89	20.5	58	29	55	1.4
G1B (Q ₃ =2.5 m ³ /h)	190	L/2	89	20.5	58	29	55	1.3

ULTRAFLOW[®] 24, G1¹/₄B and G2B

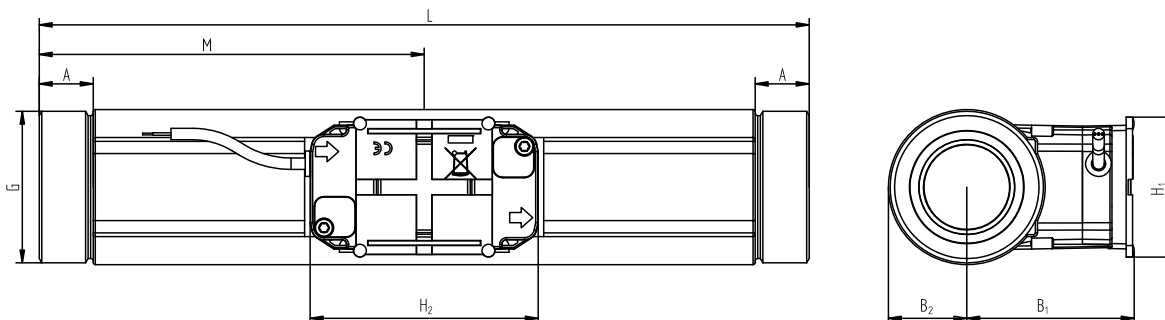

Thread ISO 228-1

Thread	L [mm]	M [mm]	H ₂ [mm]	A [mm]	B ₁ [mm]	B ₂ [mm]	H ₁ [mm]	App. weight [kg]
G1 ¹ / ₄ B (Q ₃ =4 & 6.3 m ³ /h)	260	L/2	89	17	58	22	55	2.3
G2B (Q ₃ =10 m ³ /h)	300	L/2	89	21	65	31	55	4.5

MULTICAL[®] 61

DATA SHEET



Dimensioned sketches

ULTRAFLOW[®] 24, DN50

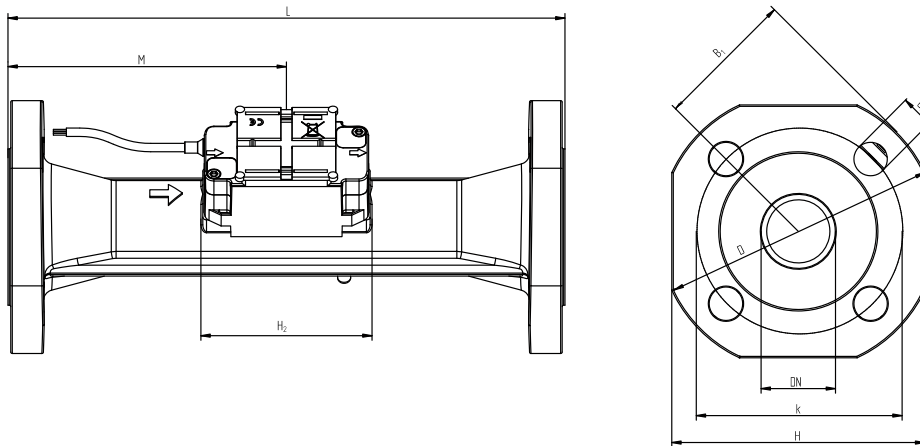

Flange EN 1092-3, PN25

Nom. dia.	L [mm]	M [mm]	H ₂ [mm]	B ₁ [mm]	D [mm]	H [mm]	k [mm]	Bolts			App. weight [kg]
								No.	Thread	d ₂	
DN50 (Q ₃ =16 m ³ /h)	270	155	89	65	165	145	125	4	M16	18	10.1

ULTRAFLOW[®] 24, DN65 and DN80

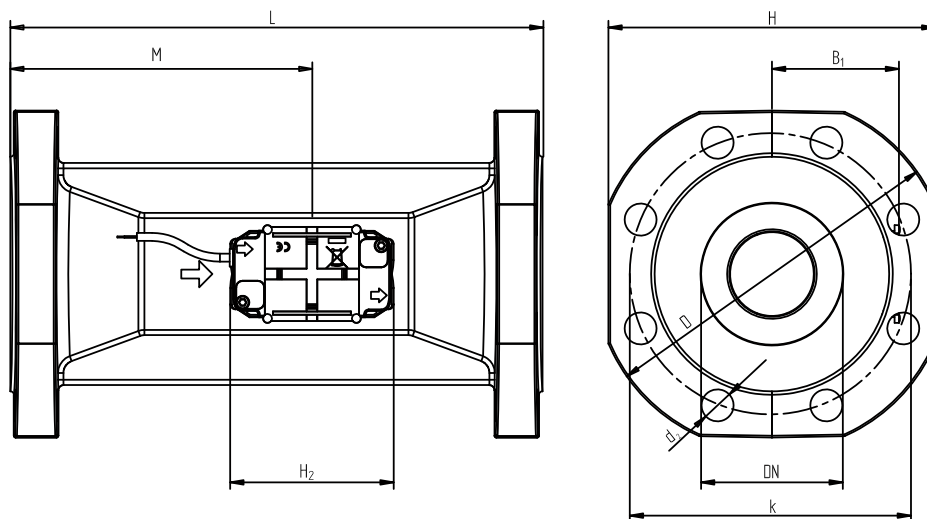

Flange EN 1092-3, PN25

Nom. dia.	L [mm]	M [mm]	H ₂ [mm]	B ₁ [mm]	D [mm]	H [mm]	k [mm]	Bolts			App. weight [kg]
								No.	Thread	d ₂	
DN65 (Q ₃ =25 m ³ /h)	300	170	89	72	185	168	145	8	M16	18	13.2
DN80 (Q ₃ =40 m ³ /h)	300	170	89	80	200	184	160	8	M16	18	16.8



Pressure loss

According to OIML R 49 the maximum pressure loss must not exceed 0.63 bar in range Q_1 up to and incl. Q_3 , or max. 1.0 bar at Q_4 respectively. The pressure loss is without anti-pollution check valve.

The pressure loss in a sensor increases with the square of the flow and can be stated as:

$$Q = k_v \times \sqrt{\Delta p}$$

where

Q = volume flow rate [m^3/h]

k_v = volume flow rate at 1 bar pressure loss [m^3/h]

Δp = pressure loss [bar]

Graph	Q_3 [m^3/h]	Nom. diameter [mm]	k_v	$Q @ 0.63 \text{ bar}$ [m^3/h]
A	1.6	DN15 & DN20	3.2	2.5
B	2.5 & 4 & 6.3	DN20 & DN25	13.4	10.6
C	10 & 16	DN40 & DN50	40	32
D	25	DN65	102	81
E	40	DN80	179	142

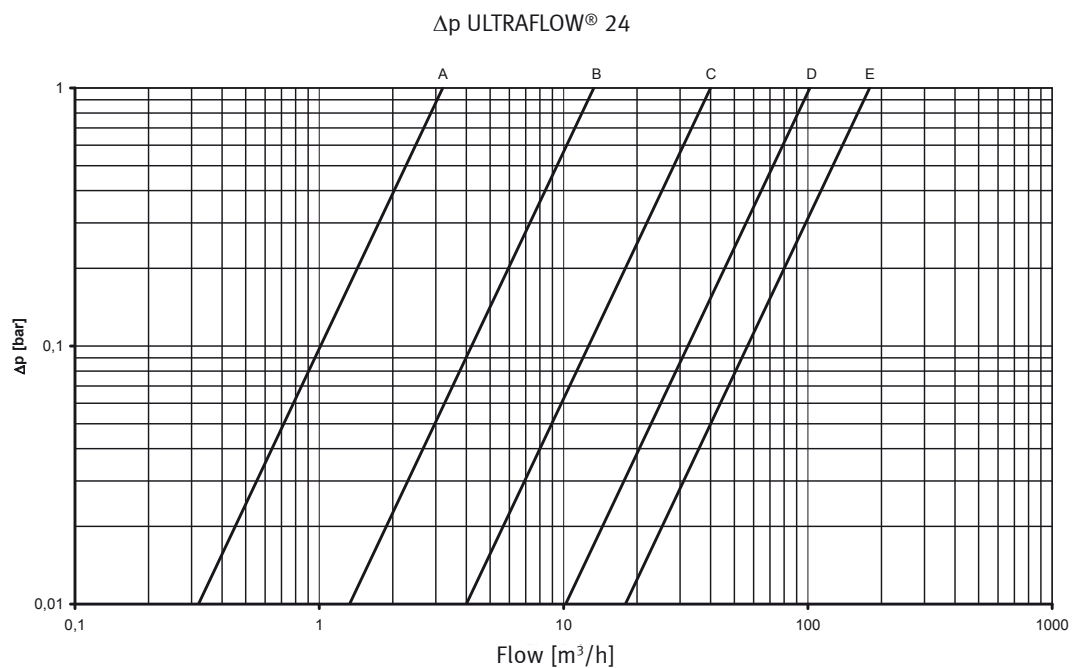

MULTICAL[®] 61

DATA SHEET



Installation angle for ULTRAFLOW[®] 24

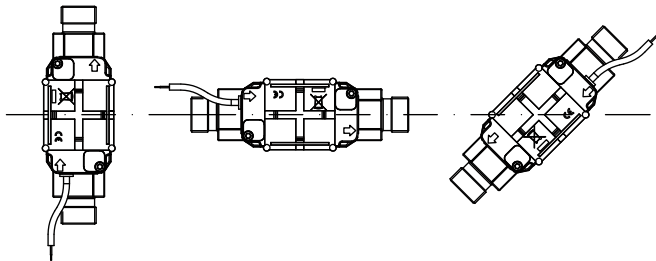

ULTRAFLOW[®] 24 can be mounted vertically, horizontally or at an angle.

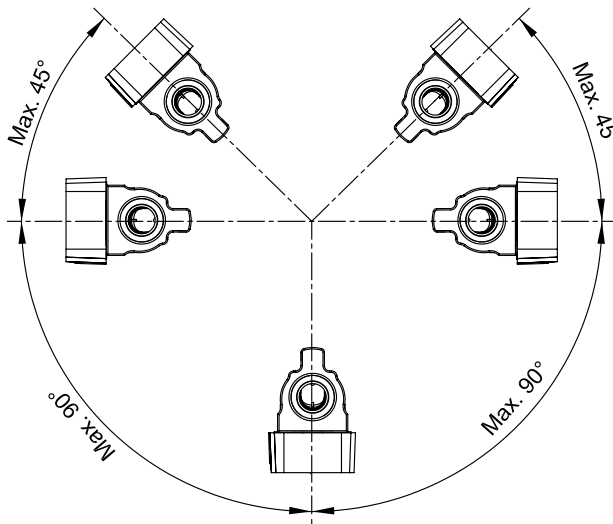

Important!

ULTRAFLOW[®] 24 can be turned upward to $\pm 45^\circ$ and down to $\pm 90^\circ$ in relation to the pipe axis.

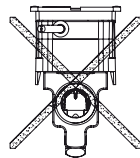

The plastic housing must **not** be mounted vertically upward.

Straight inlet

ULTRAFLOW[®] requires neither straight inlet nor outlet to meet the Measuring Instruments Directive (MID) 2004/22/EC and OIML R 49:2006. Only in case of heavy flow disturbances before the meter will a straight inlet section be necessary.



Installation example

In order to avoid condensation in the calculator it must not be mounted direct on the flow sensor.
If the calculator must be mounted on the flow sensor, angle fitting 3026-252, which is shown in the figure to the right, must be used.

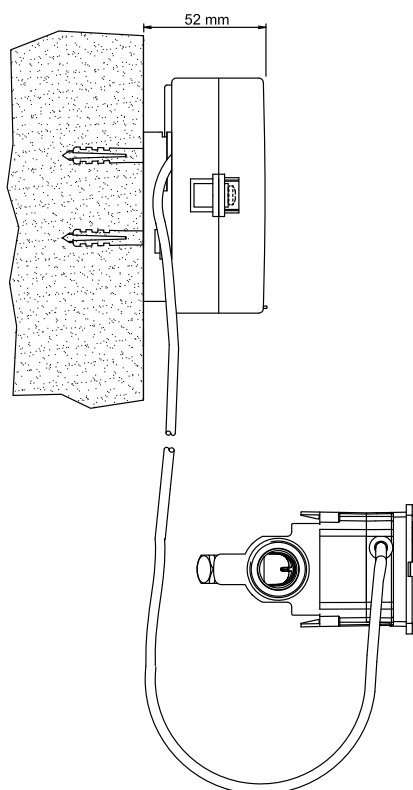

Wall mounting of the calculator

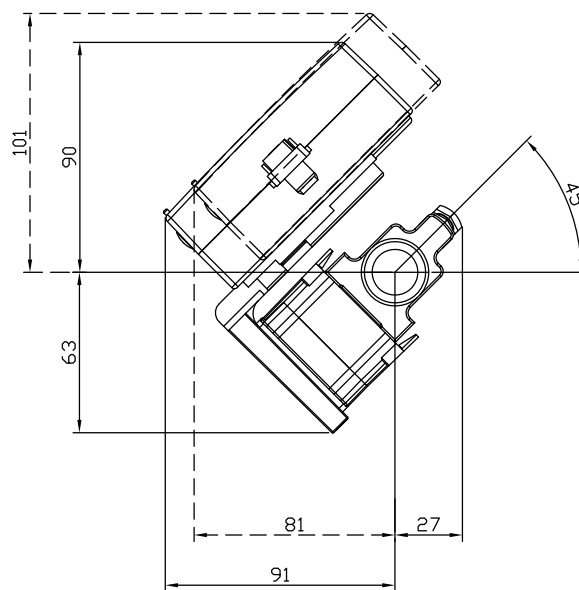

The calculator mounted on the flow part with angle fitting 3026-252