

# SVM VMH

## Multi-jet flow sensor

### DATA SHEET

- Dry-dial meter with magnetic coupling
- REED pulse output
- Rotating register
- DN15-50
- Wear resistant and corrosion proof materials
- Temperature range up to +130°C
- Versions for horizontal or vertical installation
- MID approval



### SVM VMH Multi-jet flow sensor for hot water

---

SVM VMH is a mechanical flow sensor designed to be used together with an energy meter in both heating and cooling applications and for volume measurement of tap water.

The meter is of the type multijet flow meter with a dry dial roller counter showing accumulated volume. A star wheel on the roller counter act as a flow indicator.

SVM VMH has a very good flow range with a  $q_i: q_p$  ratio of 1:50, and complies with the accuracy class 3.

The flow sensor is available in two different versions, one version for horizontal installations with either flange or thread connection, and one version for vertical installations with thread connection only.

# SVM VMH Multi-jet flow sensor

## DATA SHEET



## Application

- Volume measurement for district heating applications
- Consumption measurement for domestic use

## Pressure loss

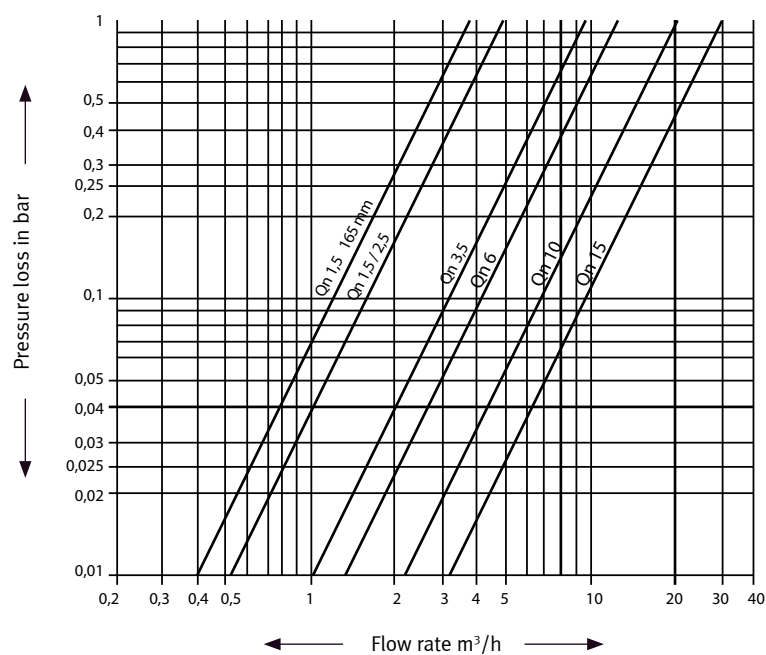

## Features

- Multi-jet dry dial with magnetic coupling
- Maximum operating temperature  $+130^{\circ}C$
- Pressure rating PN16, flanged meters PN25
- Horizontal installation, special models for vertical installation
- REED pulser
- Five digit roller counter
- Turnable counter
- Low starting flow and low pressure loss
- High grade wear resistant and corrosion proof materials
- Long-term stability and reliability
- Inlet strainer

# SVM VMH Multi-jet flow sensor

## DATA SHEET



### Dimensions

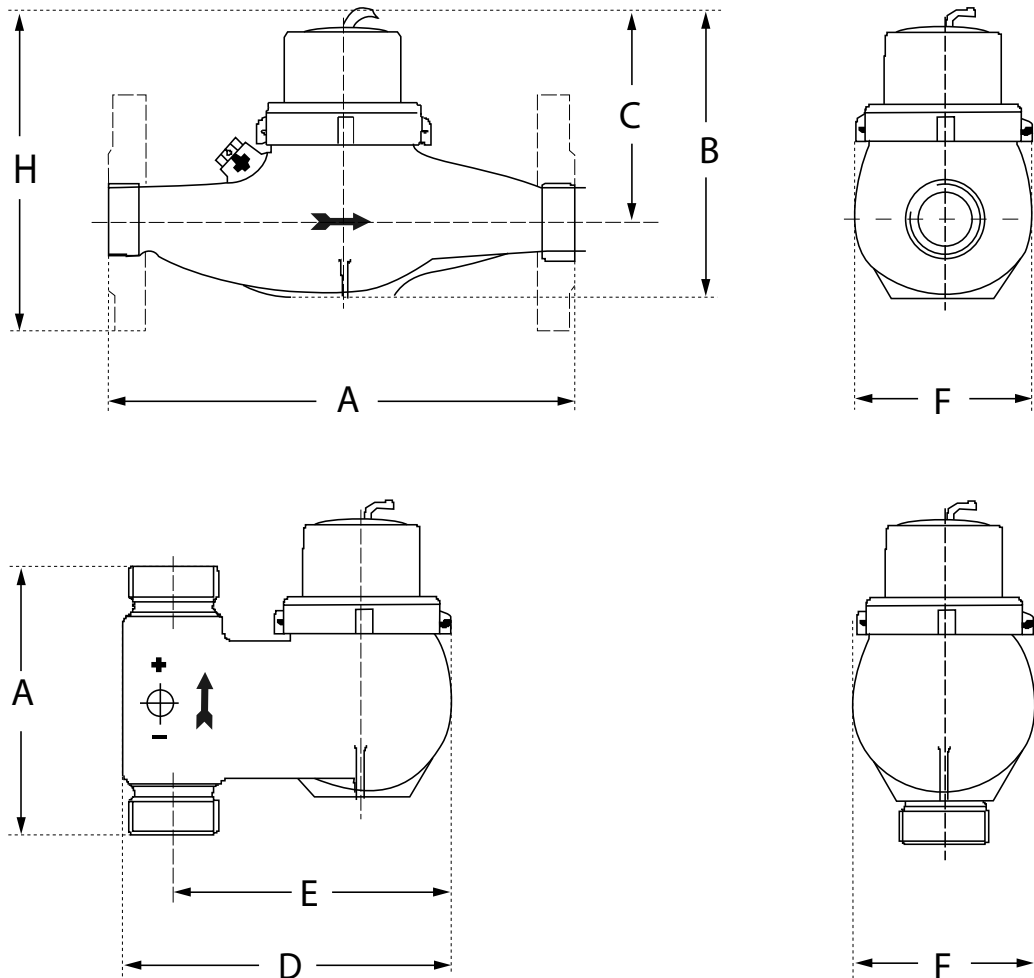

### Installation

Horizontal pipeline	—	Vertical pipeline	
Meter head upwards ↑		Meter head upwards ↑	

# SVM VMH Multi-jet flow sensor

## DATA SHEET



### Technical data

Multi-jet flow sensor VMH, <b>threaded</b> version, <b>horizontal</b> installation										
Nominal diameter	DN	mm	15	20	20	25	25	32	40	50
Connection thread on meter	G...B	Inch	¾	1	1	1¼	1¼	1½	2	2¾
Connection thread on coupling	R...	Inch	½	¾	¾	1	1	1¼	1½	2
Maximum operating pressure	PN	bar	16	16	16	16	16	16	16	16
Maximum operating temperature	Tmax	°C	130	130	130	130	130	130	130	130
Nominal flow rate	qp	m³/h	1,5	1,5	2,5	3,5	6	6	10	15
Maximum flow rate	qs	m³/h	3	3	5	7	12	12	20	30
Minimum flow	qi	l/h	30	30	50	70	120	120	200	300
<b>Dimensions</b>										
Length	A	mm	165	190	190	260	260	260	300	300
Height	B	mm	143	149	149	159	159	159	185	199
Height from pipe centre	C	mm	100	109	109	116	116	116	139	142
Width	F	mm	97	97	97	103	103	103	136	150
Weight		kg	1,8	2,1	2,1	2,7	2,7	2,8	5,3	5,8

Multi-jet flow sensor VMH, <b>flanged</b> version, <b>horizontal</b> installation										
Nominal diameter	DN	mm	20	20	25	25	32	40	50	
Maximum operating pressure	PN	bar	25	25	25	25	25	25	25	
Maximum operating temperature	Tmax	°C	130	130	130	130	130	130	130	
Nominal flow rate	qp	m³/h	1,5	2,5	3,5	6	6	10	15	
Maximum flow rate	qs	m³/h	3	5	7	12	12	20	30	
Minimum flow	qi	l/h	30	50	70	120	120	200	300	
<b>Dimensions</b>										
Length	A	mm	190	190	260	260	260	300	300	
Height	H	mm	156	156	168	168	178	208	220	
Height from pipe centre	C	mm	109	109	116	116	116	139	142	
Width	F	mm	97	97	103	103	103	136	150	
Weight		kg	3,8	3,8	5	5	5	9,9	10,4	
Flange external diameter		mm	105	105	115	115	140	150	165	
Hole circle diameter		mm	75	75	85	85	100	110	125	
Number of screws		ea	4	4	4	4	4	4	4	

# SVM VMH Multi-jet flow sensor

## DATA SHEET



### Technical data

Multi-jet flow sensor VMH, threaded version, vertical installation							
Nominal diameter	DN	mm	20	20	25	32	40
Connection thread on meter	G...B	Inch	1	1	1¼	1½	2
Connection thread on coupling	R...	Inch	¾	¾	1	1¼	1½
Maximum operating pressure	PN	bar	16	16	16	16	16
Maximum operating temperature	Tmax	°C	130	130	130	130	130
Nominal flow rate	qp	m³/h	1,5	2,5	3,5	6	10
Maximum flow rate	qs	m³/h	3	5	7	12	20
Minimum flow	qi	l/h	30	50	70	120	200
Dimensions							
<b>Length</b>	A	mm	105	105	150	150	200
Meter depth	D	mm	148	148	171	171	186
Meter depth from pipe centre	E	mm	130	130	145	146	162
Width	F	mm	95	95	100	103	134
Weight (riser/down)		kg	2,0/2,1	2,0/2,1	2,3/3,5	2,3/3,7	5,8/7,1

### Ordering key, multi jet-flow sensors

VM ABCDE-FGHIJ	AB	C	DE-FG	H	I	J
Hot water max. 130°C, horizontal pipe	21					
Hot water max. 130°C, vertical riser pipe	26					
Hot water max. 130°C, vertical down pipe	27					
Thread connection		G				
Flange connection		F				
DN15, G¾B, Qp 1,5m³/h			15-15			
DN20, G1B, Qp 1,5m³/h			20-15			
DN20, G1B, Qp 2,5m³/h			20-25			
DN25, G1¼B, Qp 3,5m³/h			25-35			
DN25, G1¼B, Qp 6,0m³/h			25-60			
DN32, G1½B, Qp 6,0m³/h			32-60			
DN40, G2B, Qp 10m³/h			40-10			
DN50, G2 B, Qp 15m³/h			50-15			
NO pulse output				0		
Pulse output 2,5 [l/p]				1		
Pulse output 10 [l/p]				6		
MID approval					M	
With magnetic screen (standard)						2
Special design						S