

Installation and User Guide for

MULTICAL® 61

Water meter



Kamstrup

www.kamstrup.com

MULTICAL® 61 Water meter

English

INSTALLATION





Kamstrup

Kamstrup A/S
Industrivej 28, Stilling, DK-8660 Skanderborg
Tel: +45 89 93 10 00 · Fax: +45 89 93 10 01
info@kamstrup.com · www.kamstrup.com

1. General information

⚠ Read this guide before installing the meter.

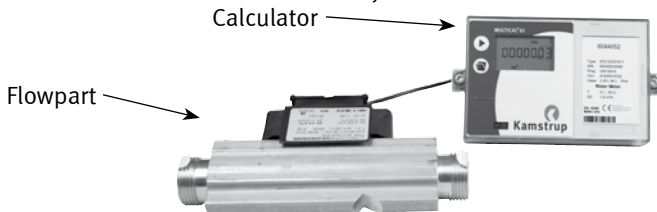
In case of incorrect mounting Kamstrup's guarantee obligations no longer apply. MULTICAL® 61 is a cold water meter (0.1...50°C) and a hot water meter (0.1...90°C) consisting of a flow sensor and a calculator. The flow sensor electronics are placed in the calculator's connecting base, whereas the calculator top is a display unit. The flow sensor is connected to the calculator by means of 2.5 m screened cable.



According to OIML R 49 MULTICAL® 61 is described as a "complete meter". In practice this means that flow sensor and calculator **MUST** not be separated. If flow sensor and calculator have been separated and the seals have thus been broken, the water meter is no longer valid for billing purposes. Furthermore, the factory guarantee no longer applies.

The accumulated water consumption to be used for billing purposes is displayed in m³ (cubic metres).

Various communication modules and power supplies can be added. The utility can replace communication module and battery.

If a longer distance (up to 10 m) is required between flow sensor and display unit, PULSE TRANSMITTER (type number 66-99-618) can be used.

See instructions 5512-587 for further information.

Smaller cold water meters 1.6 to 10 m³/h (except for G³/₄Bx110 and G1Bx110) can be fitted with a strainer (filter) and/or nonreturn valve (backflow preventer). The enclosed special polyethylene gaskets **must** be used.

Strainer, nonreturn valve and special gaskets must only be used in cold water meters.

1.1 Permissible operating conditions / measuring range

Temperature of medium in flow sensor:	Cold water meter: 0.1...50°C Hot water meter: 0.1...90°C
Pressure stage:	Threaded meters PN16 Flange meters PN25
Mechanical environment:	M1 (MID). Fixed installation with minimum vibration.
Electromagnetic environment:	E1 (MID). Housing and light industry. The meter's control cable must be drawn at min. 25 cm distance from other installations.
Climatic environment:	5°C...55°C. Must be installed indoors and in environments with non-condensing humidity.

MID = Measuring Instrument Directive 2004/22/EC.

2. Installation

In order to prevent cavitation the back pressure in the flow sensor must be minimum 1.5 bar at Q_3 and minimum 2.5 bar at Q_4 (resizes of Q_3 and Q_4 , see label on flow sensor).

The meter must not be exposed to lower pressure than the ambient pressure (vacuum).

Pressure stages are PN16 for threaded meters and PN25 for flange meters, see marking. Flow sensor marking does not cover included accessories.

Straight inlets or outlets are not required in order to comply with MID. A straight inlet section will only be necessary in case of heavy flow disturbances before the meter.

2.1 Mounting the flow sensor

Prior to the installation of the flow sensor the system ought to be flushed, a fitting piece replacing the meter.

Remove adhesive wafers/ protection membranes from the meter's inlet and outlet and mount the flow sensor.

You must always use new gaskets in original quality.

The flow direction is indicated by an arrow on the side of the flow sensor.

Threaded meters are mounted by means of glands. You must make sure that the threaded lengths of the glands do not prevent proper tightening of sealing surfaces and that PN10 glands are used (PN16 glands/gaskets can be used).

Using strainer and/or nonreturn valve the enclosed thicker PE (polyethylene) gaskets **must** be used in order to avoid damaging strainer or nonreturn valve.

Strainer, nonreturn valve and PE-gaskets must only be used in cold water meters.

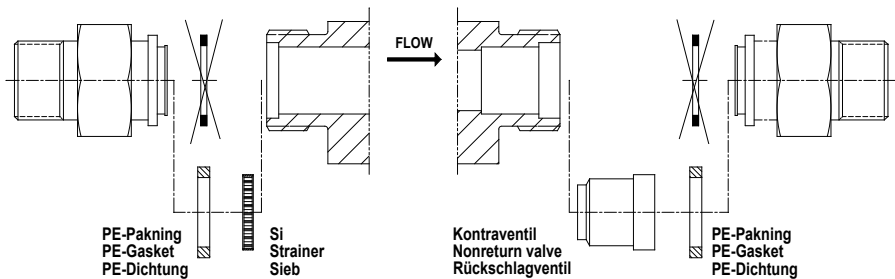

2.2 Installation angle for ULTRAFLOW® 24

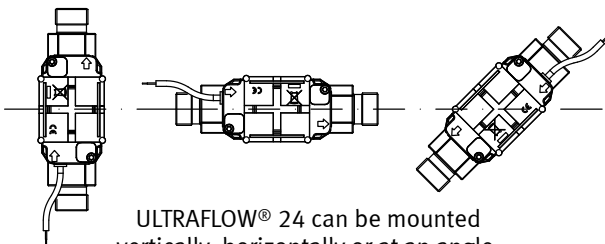

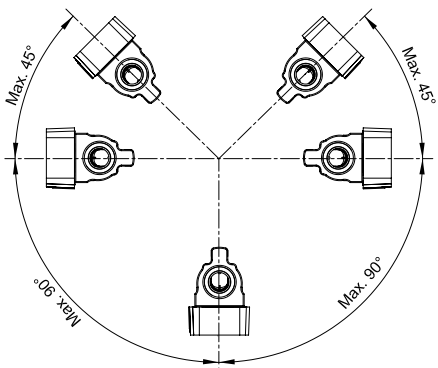

Important! ULTRAFLOW® 24 may be turned upwards to max. 45° and downwards to max. 90° in relation to the pipe axis.

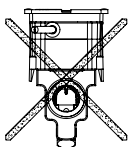

The plastic housing must **not** be turned upwards.

2.3 Mounting of calculator

If the electronics are exposed to the risk of condensation, MULTICAL® 61 must be mounted on a wall.

Use the fitting as a template to mark and drill two 6 mm holes in the wall.

Alternatively, an angle fitting is mounted on the flow sensor (type no. 3026-252, is ordered separately).

The cable must be mounted minimum 25 cm from other electric installations.

Do not forget to seal the calculator.

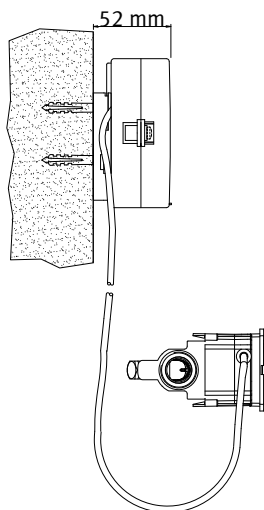

Wall mounted

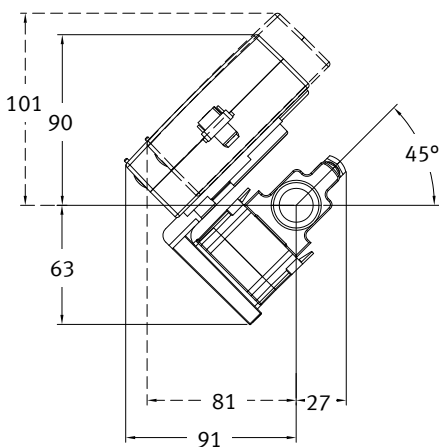

Mounted on flow sensor with angle fitting 3026-252

4. Testing the function

Carry out a function control when the meter has been fully mounted. Activate the pushbutton ► on MULTICAL® 61 and check that the displayed values for water flow etc. are credible values.

5. Plug-in modules

A number of extra functions can be added to MULTICAL® 61 by means of plug-in modules. The individual modules are briefly described below.

5.1 BASE MODULES

5.1.1 Data + pulse inputs, type 67-00-10

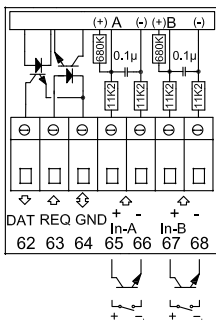

The data terminals are used for connection of e.g. a PC. The signal is passive and galvanically separated by means of optocouplers. Conversion into RS232 level requires connection of data cable 66-99-106 (D-Sub 9F) or 66-99-098 (USB) with the following connections:

62	Brown	(DAT)
63	White	(REQ)
64	Green	(GND)

The pulse inputs can be used for connection of electricity and water meters.

Please note the maximum pulse frequency as well as correct pulse coding (l/imp. and Wh/imp.), which are selected by means of the FF and GG configurations.

65 - 66	Input A
67 - 68	Input B

5.1.2 M-Bus, type 67-00-20

M-Bus can be mounted in star, ring and bus topology. Up to 250 meters can be connected depending on the M-Bus Master's power supply and the total cable resistance.

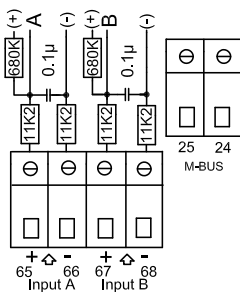

Cable resistance < 29 ohm
Cable capacity < 180 nF

The M-Bus network is connected on terminals 24 and 25. The polarity is unimportant. M-Bus is supplied with pulse inputs.

5.1.3 Radio + pulse inputs, type 67-00-21/25/26

The radio module is used for wireless communication via licence-free radio frequency and can be supplied with internal antenna or with connection for external antenna.

For further information on radio we refer to *Technical description for radio (5512-012 DK, 5512-013 GB)*.

The pulse inputs of this module are identical with the previously described pulse inputs.

Note! Type 67-00-21 includes radio and router functions. The RadioRouter module must be used with mains supply.

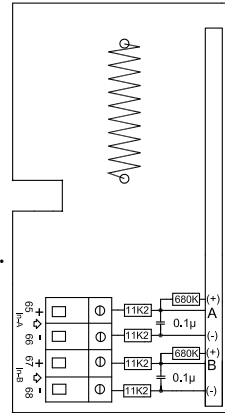

5.1.4 Prog. data logger + RTC + 4...20 mA inputs + pulse inputs (67-00-22)

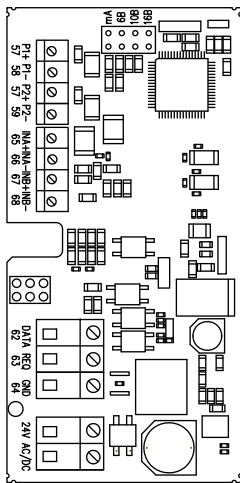

The module has connection possibility for two pressure transmitters on terminals 57, 58 and 59 and can be adjusted for current reading or pressure ranges of 6, 10 or 16 bar.

The module is prepared for remote reading, data from meter/module being transferred to the system software via the connected external GSM/GPRS modem on terminals 62, 63 and 64.

Furthermore, the module has two extra pulse inputs, VA and VB.

The module must be powered by 24 VAC.

5.1.5 Analog output

Type 67-00-23, see *installation instructions 5512-369 (DK-GB-DE)*.

5.1.6 Lon Works

Type 67-00-24, see *installation instructions 5512-396 (DK) or 5512-403 (GB)*.

5.2 TOP MODULES

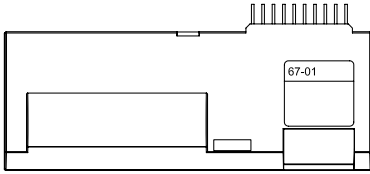

Type 67-01: RTC, Real Time Clock

The top module consists of real time clock and battery backup. When the MULTICAL® 61 calculator top is placed in the connection bracket, thereby being powered, the top module transfers current date and time to the calculator.

The top module is recommended for applications where correct date/time in data loggers as well as time controlled tariff is important.

Real time clock and battery backup are included in all other top modules.

The connection terminals are not used in this module.

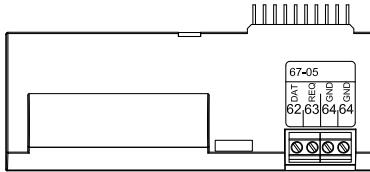

Type 67-05: RTC + data output + hourly data logger

The module has a galvanically separated data port which functions with the KMP protocol. The data output can be used for e.g. connection of external communication units or other hardwired data communication which it is not expedient to carry out via the optical communication on the meter's front.

62: DATA (brown) – 63:REQ (white) – 64: GND (green). Use data cable type 66-99-106 with 9-pole D-sub or type 66-99-098 with USB connector. Furthermore, the module includes an hourly data logger.

Only current and accumulated data can be read. Hourly/daily/monthly/yearly data loggers cannot be read through the data port of top module 67-05.

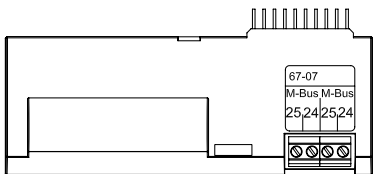

Type 67-07: RTC + M-Bus

M-Bus can be connected in star, ring and bus topology. Depending on M-Bus Master and cable length/cross section up to 250 meters with primary addressing can be connected, and even more using secondary addressing.

Cable resistance in network: < 29 ohm

Cable capacity in network: < 180 nF

The connection polarity of terminals 24-25 is unimportant.

Unless otherwise stated in the order, the primary address consists of the last three digits of the customer number, it can be changed, however, via the PC program METERTOOL.

Module to be used in mains supplied meters only.

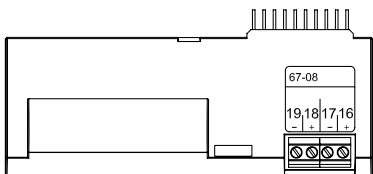

Type 67-08: RTC + pulse output for CV + hourly data logger

This top module has configurable pulse output, which is suitable for volume pulses for water meters. The pulse resolution follows the display (determined by the CCC-code). E.g. CCC=419 (Q3= 1.6 m³/h): 1 pulse/0.01m³.

The pulse outputs are optoisolated and withstand 30 VDC and 10 mA.

Volume (CV) is typically connected to 18-19, but can also be connected to 16-17 as the two outputs are identical. (The outputs are identically configured if the module is mounted in MULTICAL® 61).

Via the PC-program METERTOOL the pulse duration can be selected at 32 or 100 ms.

The module also comprises an hourly data logger, which includes the same registers as the daily logger.

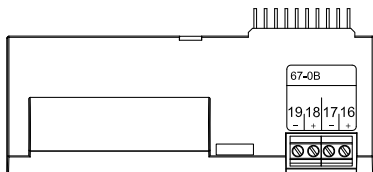

Type 67-0B: RTC + pulse output for CV + prog. data logger

The RTC and pulse output functions of this top module are identical with the functions described for top module 67-08.

The top module is prepared for use in a Kamstrup radio network together with the RadioRouter base module 67-00-21-000-3xx, read data being transferred to the system software via the network unit RF Concentrator.

6. Retrofitting modules

Both top modules and base modules for MULTICAL® 61 can be supplied separately for retrofitting. The modules are configured and ready for installation from the factory. Some of the modules require individual configuration after installation, which is possible by means of METERTOOL.

Top module		Possible configuration after installation
RTC (Real Time Clock)	1	Clock adjustment.
RTC + data output + hourly data logger	5	Clock adjustment.
RTC + M-Bus	7	Clock adjustment. Primary and secondary M-Bus addresses can be changed via METERTOOL or M-Bus. Furthermore, monthly logger data can be selected instead of yearly logger data via M-bus.
RTC + pulse output for CV + hourly data logger	8	Clock adjustment. Configuration of pulse output. (Configured from the factory according to customer requirements)
RTC + pulse output for CV + prog. data logger	B	Clock adjustment. Configuration of pulse outputs.
Base module		
Data + pulse inputs	10	Pulse values of VA and VB are changed via METERTOOL.
M-Bus + pulse inputs	20	Pulse values of VA and VB are changed via METERTOOL. Primary and secondary M-Bus addresses can be changed via METERTOOL or M-Bus. Furthermore, monthly logger data can be selected instead of yearly logger data via M-bus.
RadioRouter + pulse inputs	21	Pulse values of VA and VB are changed via METERTOOL.
Prog. data logger + RTC + 4...20 mA inputs + pulse inputs	22	Clock adjustment. Pulse values of VA and VB are changed via METERTOOL.
0/4...20 mA outputs	23	Config data must be programmed into the calculator by means of METERTOOL when retrofitting. Furthermore, all parameters can be changed via METERTOOL.
LonWorks, FTT-10A + pulse inputs	24	Pulse values of VA and VB are changed via METERTOOL. All other configurations are made via LonWorks.
Radio + pulse inputs (integral antenna)	25	Pulse values of VA and VB are changed via METERTOOL.
Radio + pulse inputs (connection for external antenna)	26	Pulse values of VA and VB are changed via METERTOOL.

7. Information Codes "INFO"

MULTICAL® 61 constantly monitors a number of important functions. If there is a serious error in measuring system or installation, a flashing "INFO" will appear in the display until the error has been corrected. The "INFO" field flashes as long as the error exists no matter which reading you choose. The "INFO" field automatically disappears when the reason for the error has been removed.

When the first permanent information code appears it is saved in the EEPROM together with the date and the volume registers at the time the error occurred.

Furthermore, the info code is saved in the hourly logger (if a top module with hourly logger is mounted), the daily logger, the monthly logger and the yearly logger for diagnosis purposes.

Info code types

Info	Description	Response time
0	No irregularities	-
1	Supply voltage has been interrupted	-
16	Flow sensor V1, communication error, signal too weak or wrong flow direction	After reset (e.g. cover off and on) as well as automatically after max. 24 hours (at 00:00)
64	Leak in water installation	24 hours
2048	Flow meter V1, wrong pulse figure	After reset (e.g. cover off and on) as well as automatically after max. 24 hours (at 00:00)
4096	Flow meter V1, signal too weak (air)	
16384	Flow meter V1, wrong flow direction	

If several info codes appear at a time, the sum of the info codes is displayed.

Example: E2064 = E16 + E2048.

7.1 Transport mode

The meter leaves the factory in transport mode, i.e. the info codes are active in the display only, not in the data logger. This prevents "infoevent" from counting during transportation and non-relevant data from being saved in the info logger. The first time the meter totalizes the volume register after the installation, the info codes automatically become active.

8. Troubleshooting

MULTICAL® 61 has been constructed with a view to quick and simple installation as well as long and reliable operation at the consumer.

Should you, however, experience an operating problem, the table below can be used for troubleshooting.

If repair of the meter becomes necessary, we recommend you to replace parts like battery and communication modules only. Alternatively, the whole meter ought to be replaced.

Major repairs must be made by Kamstrup A/S.

Before sending in the meter for repair or check, please use the error detection table below to help you clarify the possible cause of the problem.

Symptom	Possible reason	Proposal for correction
The display value is not updated	Power supply missing	Change battery or check mains supply
No display function (empty display)	Power supply missing	Change battery or check mains supply. Is there 3.6 VDC on terminals 60(+) and 61 (-)?
If "INFO" = 1	Supply voltage has been interrupted	The info code is corrected automatically
No accumulation of volume (m ³)	Read "INFO" in the display	Check the error indicated by the info code
If "INFO" = 16	Communication error or signal too weak or wrong flow direction	There is air in the flow sensor? Bleed the system and check the meter again. Check that the flow direction matches the arrow on the flow sensor
If "INFO" = 2048	Flow sensor programmed with wrong pulse figure	Contact Kamstrup A/S
If "INFO" = 4096	Signal too weak	There is air in the flow sensor? Bleed the system and check the meter again
If "INFO" = 16384	Flow sensor mounted in wrong direction	Check that the flow direction matches the arrow on the flow sensor

Menu Structure

VOL
1
0032456
m³

Water consumption
Please note! This is the field used for billing

h
0008760

Number of operating hours

VOL
1/h
316

Current water flow

INFO
4096

Current information code
See INFO codes on the backpage

N°
123

The up to eight most significant digits of the customer number

DATE **LOG**
1 009060
1
LOG
002564
1
m³

Latest target date

Volume counter on latest target date followed by volume counter on last year's target date followed by *monthly* counters

DATE **MAX**
1 20090317
1
MAX
1474
1/h

Date of max. flow this year

Value of max. flow this year followed by the values of max. flow for the last 2 years

DATE **MIN**
1 20091003
1
MIN **VOL**
1/h 8

Date of min. flow last month

Value of min. flow last month followed by the values of min. flow for the last 12 month

INFO **N°**
1 6
1

Reading of number of INFO code events

The data logger shows the date and then the INFO codes of the latest 36 events

DATE **LOG**
1 20090104
1
INFO **LOG**
1 64
1

N°
45678912

The eight least significant digits of the customer number. In this example the customer number is 12345678912

DATE **LOG**
1 20091129
1

Current date followed by current time

DATE **LOG**
1 060
1

Target date displayed as month and day, in this example 1 June

N°
6014234

The calculator's serial number

N°
34419414

The program number of the calculator.

Followed by configuration codes DDD-EE and FF-GG-M-N, software version and software checksum Display test

SCHEMATA MAX 3.1.1.1.12
TYPE: 00000000000000000000
DATE: 00000000000000000000
TEMP °C 1. Gas. kWh
MWH m³/h m³/h G3 MWH

Please note:

Readings written in *italics* are not shown by an example.
_ = comma frame marking the number of decimals.

Also see interactive user guides at www.kamstrup.com

MULTICAL® 61

Volume

MULTICAL® 61 has been developed and type approved according to the newest standards. (OIML R49 and the Measuring Instrument Directive (MID) 2004/22/EF).

Readings

When the top front button  (primary register) is activated, the next reading is displayed.

The following is shown

- Readings are VOLUME in m³ (total quantity)
- Number of OPERATING HOURS
- Actual FLOW in l/h
- INFO CODE
- CUSTOMER NUMBER

The bottom front button  (secondary register) is used to collect historic readings and average values, e.g. monthly data, yearly data etc. depending on the selected configuration.

The display automatically returns to reading of "VOLUME" after 4 minutes.



www.kamstrup.com

Information Codes

MULTICAL® 61 constantly monitors a number of important functions. If there is a serious error in measuring system or installation, a flashing "INFO" will appear in the display until the error has been corrected. The "INFO" field flashes as long as the error exists no matter which reading you choose. The "INFO" field automatically disappears when the reason for the error has been removed.

Info code types

Info	Description	Response time
0	No irregularities	-
1	Supply voltage has been interrupted	-
16	Flow sensor V1, communication error, signal too weak or wrong flow direction	After reset (e.g. cover off and on) as well as automatically after max. 24 hours (at 00:00)
64	Leak in water installation	24 hours
2048	Flow meter V1, wrong pulse figure	After reset (e.g. cover off and on) as well as automatically after max. 24 hours (at 00:00)
4096	Flow meter V1, signal too weak (air)	After reset (e.g. cover off and on) as well as automatically after max. 24 hours (at 00:00)
16384	Flow meter V1, wrong flow direction	After reset (e.g. cover off and on) as well as automatically after max. 24 hours (at 00:00)

If several info codes appear at a time, the sum of the info codes is displayed. Example: E2064 = E16 + E2048.

If "INFO" flashes, contact the utility.

U S E R F R I E N D G U I D E