

## Installation guide

# SVM F4 Calculator

Delivery · Commissioning · Connections · Mounting · Functional test



SVM AB  
Tullgatan 5, SE-371 39 Karlskrona  
Tel: +46 455 33 19 00 · Fax: +46 455 33 19 01  
karlskrona@kamstrup.se · www.kamstrup.se



# Content

---

<b>Delivery</b>	<b>4</b>
<b>Commissioning</b>	<b>4</b>
<b>Connections</b>	<b>6</b>
<b>Connecting flow sensor ULTRAFLOW® 54</b>	<b>9</b>
<b>Cable glands</b>	<b>9</b>
<b>Dimensions</b>	<b>10</b>
<b>Mounting</b>	<b>11</b>
<b>Functional test</b>	<b>11</b>

# Delivery

---

Calculator F4 can be delivered in various power supply options. F4 with battery supply is delivered with a C-cell or a D-cell. F4 with mains supply is also equipped with a C-cell for back-up. Note that some option boards require mains supply. For more information, see the data sheet for each option board.

Calculator F4 is delivered in transport mode. Only the RTC is active in transport mode, and no measurements take place. Transport mode is indicated on the LCD with the word “no” displayed in the upper left corner.

# Commissioning

---

Press and hold the push button for 5 seconds in order to exit the transport mode, and enter init mode. Init mode is really the same thing as service mode, but some sequences are left out in init mode. When entering init mode the LCD changes and “00” is displayed in the upper left corner.

Init/Service mode contains the following menu sequences:

00	RTC [HHMM]
01	Date [YMMDD]
02	Pulse value, without decimals [0000-9999]
03	Pulse value, no. of decimals [0-4]
04	Account day 1 [YMM] (n.a. in init mode)
05	Account day 2 [YMM] (n.a. in init mode)
06	Primary communication address [0000-0255]
07	Reset error time [0=reset, 1=save] (n.a. in init mode)
08	Flow sensor placing [0=low temperature, 1=high temperature] (n.a. in init mode)
09	Recommended battery replacement date [YMMDD] (n.a. in init mode)
0A	Exit init/service mode [0=return to “00”, 1=go to operation mode “10”]

Table 1

# Commissioning

---

Use the push button to change the meter settings according to the init/service sequence above.

The push button has a dual function. When the button is pressed and held the meter toggles through the service sequence without any values being changed. When the button is pressed and released again, the value of the current flashing digit is changed one step (+1).

## **Use the push button, as in the example below to change the date:**

1. Sequence "00" is displayed when the meter is set into init mode. Keep the button depressed until sequence "01" is displayed.
2. Sequence "01" is displayed with YYYYMMDD = 110520. The first digit flashes. The date shall be set to 110525.
3. Press and hold the push button until the next digit starts flashing, and keep the button depressed until the last digit, the one to be changed, starts flashing.
4. Press and release the button five times until the last digit is set to 5.
5. Press and hold the push button again until sequence "02" is displayed.
6. When all desired changes are made, press and hold the push button until sequence "0A" is displayed.
7. Press and release the push button to change the digit in sequence "0A" from 0 to 1.
8. Press and hold the push button once again until sequence "10" (operation mode) is displayed.

**Note!** Meters delivered with a customized setting can go directly from transport mode to operation mode (sequence 10).

After leaving init mode it is only possible to return to service mode by pressing the sealed service button, cf. the user manual for F4.

# Connections

SVM F4 is equipped with connecting pins for option boards and terminal blocks for connecting signal leads, located under the lid in the base of the meter. Connect the signal leads to the screw terminals according to Table 2, below:

Terminal no acc. to EN1434	Marking on terminal	Signal
1	"Filled thermometer"	Temperature sensor, high temperature (4-wire connection only)
2	"Filled thermometer"	Temperature sensor, high temperature (4-wire connection only)
3	"Unfilled thermometer"	Temperature sensor, low temperature (4-wire connection only)
4	"Unfilled thermometer"	Temperature sensor, low temperature (4-wire connection only)
5	"Filled thermometer"	Temperature sensor, high temperature
6	"Filled thermometer"	Temperature sensor, high temperature
7	"Unfilled thermometer"	Temperature sensor, low temperature
8	"Unfilled thermometer"	Temperature sensor, low temperature
10	+	Flow sensor pulse input (signal)
11	-	Flow sensor pulse input (GND)
9	+3V	Flow sensor power supply
24	MBUS	Data output M-Bus*
25	MBUS	Data output M-Bus*
51	D2	Alarm output (GND)
n.a.	IN -	Pulse inlet, common signal zero (GND)
n.a.	IN 1	Pulse inlet 1 (signal)
n.a.	IN 2	Pulse inlet 2 (signal)
17/19	OUT -	Pulse outlet, common signal zero (GND)
16	OUT 1	Pulse outlet 1, energy (signal)
18	OUT 2	Pulse outlet 2, volume (signal)
50	D1	Alarm output (signal)
60	A1	Data output SIOX (option)
61	A2	Data output SIOX (option)
* When an option board for additional M-Bus, FCMB or an option board for galvanic isolation of the M-Bus, FCR2, is installed, use the screw terminals corresponding to the selected card slot for connection of the M-Bus loop. See also the data sheet for each option board.		

Table 2, Screw terminals in F4

# Connections

---

Mains supplied calculators have separate screw terminals for connecting the mains cable.

## Flow sensors

Mechanical flow sensors with minimum pulse duration of 40ms and a maximum pulse frequency of 12Hz can be connected to F4. Also the ultrasonic flow sensor SVM ULTRAFLOW® 54 may be used together with F4. Connect the flow sensor signal leads according to Table 2 below.

**Note!** F4 calculators connected to flow sensor ULTRAFLOW® 54 must be equipped with a power supply suitable for this purpose. Older versions of F4, delivered in 2010 and earlier have a different type of power supply and should not be connected to the ULTRAFLOW® 54, as battery life and back-up supply can be affected.

**Note!** When F4 is connected to flow sensor ULTRAFLOW® 54, no inlets or outlets may be connected to ground, due to the risk of ground loops.

## Temperature sensors

Temperature sensors of the type Pt100 or Pt500, with 2-wire or 4-wire connection may be used. Note that the jumpers on the connection board of the meter must be removed to enable the 4-wire connection, cf. Fig.2 below.

## Pulse outlets and pulse inlets

F4 is delivered with 2 pulse outlets for energy and volume, and with 2 pulse inlets. All inlets and outlets, including the alarm outlet, can be made galvanically isolated by installing the option board FCRC into the meter, cf. the data sheet for Relay option board FCRC.

## Data output

F4 is delivered with a built-in data output for 2-wire M-Bus. With a variety of option boards several parallel data outputs are available, e.g. additional M-Bus outputs, SIOX or LON. Cf. the data sheet for each option board for more information.

# Connections

Fig. 1, Screw terminals in F4

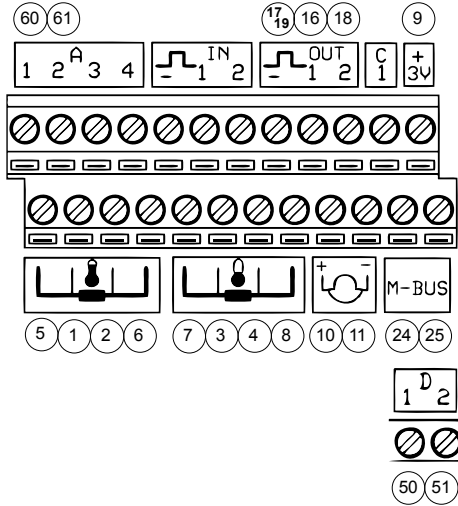

Option board slots  
A B C D E

Four pole connectors "K3"  
and "K4" for power supply.  
Disconnect to cut the power.

Screw terminals for  
the option boards  
A B C D E

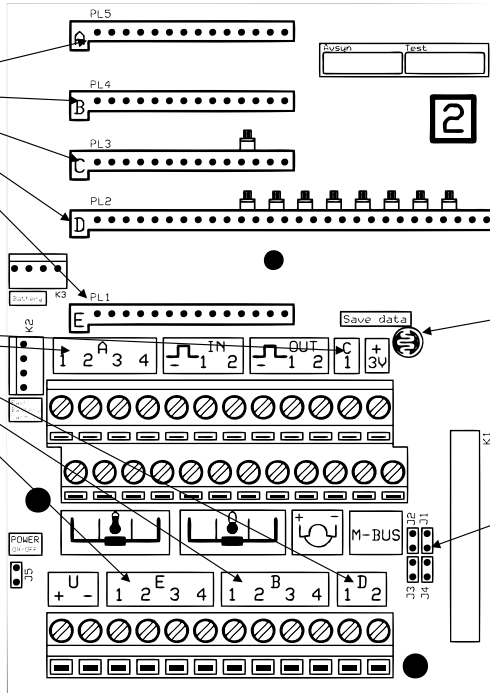

Short circuit  
to save data

Remove jumpers  
to enable 4-wire  
connection of  
temperature sensors

Fig. 2, Connection board  
in F4

# Connecting flow sensor ULTRAFLOW® 54

SVM F4 with battery or mains supply suitable for supplying the flow sensor, can easily be connected to flow sensor ULTRAFLOW® 54. Connect the signal leads from the flow sensor according to Table 2 and Fig. 3 below.

ULTRAFLOW® 54, wire	Function	F4 marking on terminal
Red	Supply	+3V
Yellow	Signal	+
Blue	GND	-

Table 2, Connecting ULTRAFLOW® 54 to F4

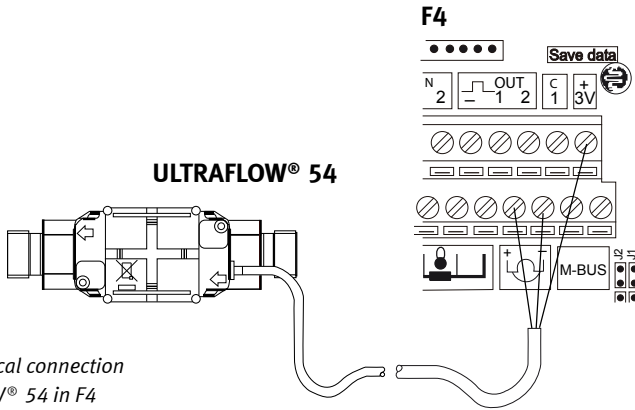

Fig. 3, Electrical connection of ULTRAFLOW® 54 in F4

## Cable glands

F4 have 6 PG cable glands for signal leads. The protection class for the electronic casing comply with IP54.

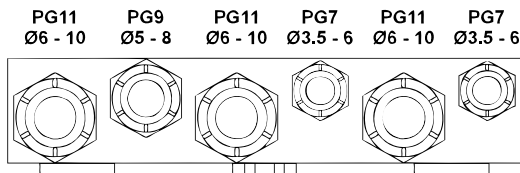

Fig.4, Cable glands

# Dimensions

All dimensions in [mm].

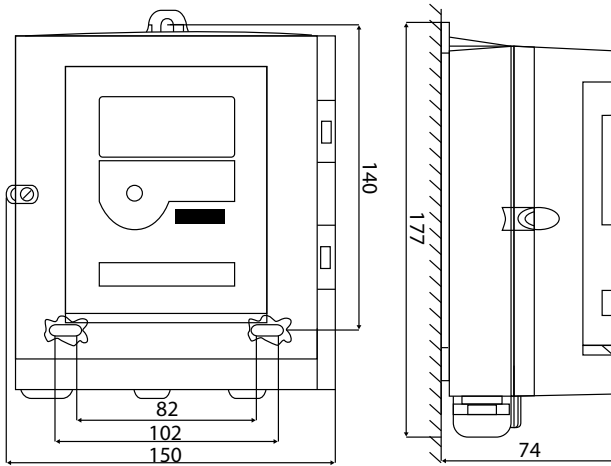

Fig. 5, Dimensions

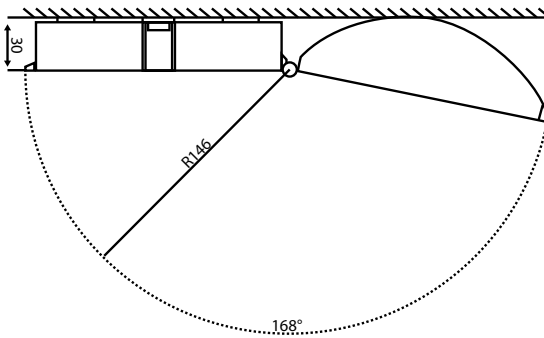
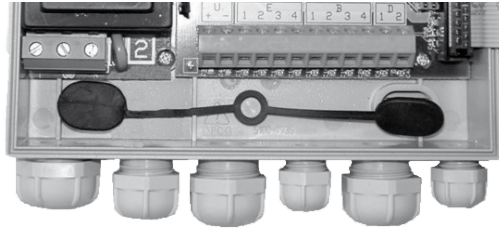

Fig. 6, Wall mounting

# Mounting

---

F4 is designed for wall mounting, cf. Fig. 4 and Fig. 5. After installation the holes should be sealed with the enclosed rubber plugs, see Fig. 6.



*Fig. 6, F4 rubber seal*

# Functional test

---

After installation, it is recommended to perform a simple test, to ensure that the calculator has been properly installed. Always check the following before the meter installation is considered finalized:

1. If there currently is a flow through flow sensor, check that the flow indicator (a square symbol) in the lower left corner is flashing. Also check that the momentary flow rate in display sequence 21 is reasonable.
2. Check the error code in display sequence 15. If everything is OK the LCD will display "000000". If error code 40 appears, this means "low flow". Wait until the flow sensor emits a pulse and check the error code again.
3. To ensure that the temperature sensors have been installed correctly, check the forward temperature, return temperature and the temperature difference in display sequences 22, 23 and 24.
4. Ensure that the pulse value in display sequence 63 corresponds to the pulse value on the flow sensor label.
5. Check the date, real time clock and the communication address.



[www.kamstrup.com](http://www.kamstrup.com)