

Installation Guide

PQT-Controller
MULTICAL® 601/602/801

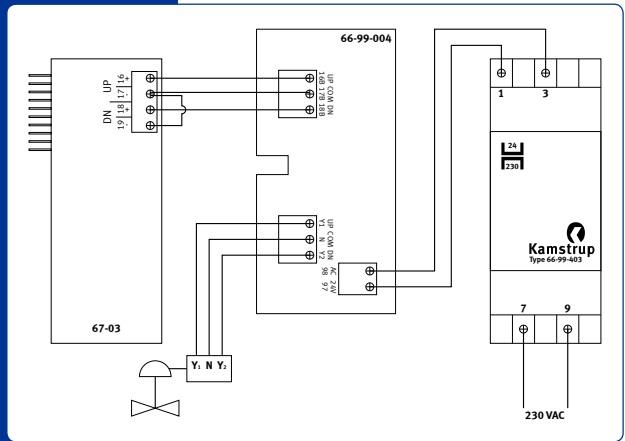

Contents

1	Introduction	2	4.4 Installation principle	8
2	Function	3	5 Operation	8
3	Flow Controller and valve specification		5.1 Operation by METERTOOL	8
4		6	Trouble shooting	10
	3.1 General data	4		
	3.2 Dynamic range	5		
4	Installation: 24 VAC	6		
	4.1 Installations diagram for MULTICAL® 601/602	6		
	4.2 Installations diagram for MULTICAL® 801	7		
	4.3 Testing the installation	7		

1 Introduction

MULTICAL® 601, 602 and 801 can control a motor-operated valve for projects, where power and/or flow control is required. Further more the temperatures ΔT and T_2 can be added as additional control parameters. The PQT-controller is based on the power, flow and temperature limits programmed into the calculator.

These parameters are entered by use of the PC-software METERTOOL for HCW (type 6699-724).

For MULTICAL® 601 and 602 it is necessary to install top module 67-03 to be able to use the PQT-controller function. The limitation function is controlled by the top module, and not by the meter.

For MULTICAL® 801 the PQT-controller function is built in to the meter.

The pulse outputs are used to control the motor-operated valve.

2 Function

PQT-controller function ensures that the limits are not exceeded.

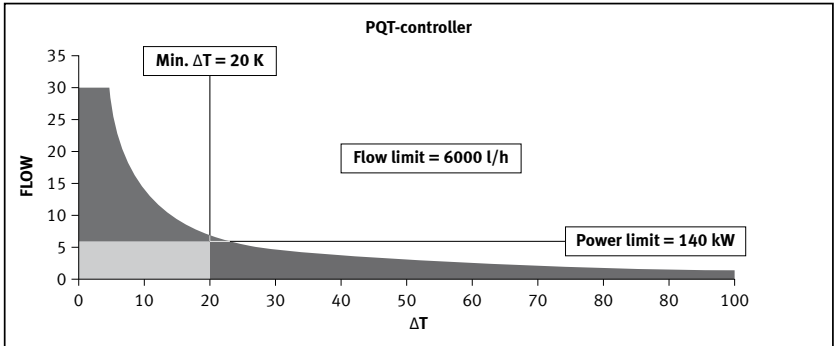

The above chart shows how the PQT-controller ensures that the limit of e.g. 140 kW is not exceeded. At low cooling (e.g. below 20 K), the controller function ensures that a limit of e.g. l/h is not exceeded.

As additional parameters further regulation can be carried out by minimum ΔT and maximum T_2 . If these limits are exceeded the system will reduce flow and force a higher ΔT and/or lower T_2 . To ensure the regulation functionality ΔT and T_2 regulation is only active above a programmable minimum flow. If the flow drops below this value the system will ignore the ΔT and T_2 functions.

If only power control is required, the "Flow limit" is marked "Deactivated" and if only flow control is required the "Power limit" is "Deactivated".

If no ΔT function is required the limit "Min T_1 - T_2 limit" is marked "Deactivated" and if no T_2 function is required the limit "Max T_2 limit" is marked "Deactivated".

"UP-COM-DN" output terminals are used as Y1 and Y2 control output for the motor-operated valve.

The control function requires a relative fast signal from the attached flow meter.

Because of this mechanical flow meters with Reed-contact output (CCC=0XX) can not be used.

As the pulse outputs are only intended for low current and low voltage signal levels a Kamstrup flow controller must be used when connecting the motor-operated valve.

3 Flow Controller and valve specification

Flow Controller Type nr. 66-99-003.

Technical data of the Flow Controller:

Output stage:	Triac, galvanic isolated.
Supply power [97-98]:	24 VAC
Motor voltage:	24 VAC
Motor current:	< 1,0 A
Mutual blockage:	None

The motor-operated valve must have total valve reaction time of between 120...460 sec.

If a motor-operated valve has a spindle velocity of 10 sec./mm and the matching valve has a spindle movement of 25 mm, the total valve reaction time will be 250 sec.

Faster motor-operated valves with spindle velocity of e.g. 1...3 sec./mm are generally not suitable for heat systems, and cannot be used in relation with the MULTICAL® 601, 602 and 801.

At delivery the regulation parameters are setup to default (please see screen dump at page 9). When the PQT-controller is put into operation the parameters can be changed by use of METERTOOL HCW.

3.1 General data

Control function:	3-position contact function
Motor-operated valve:	24 VAC
Characteristics:	Linear
Valve reaction time:	120....460 sec.

3.2 Dynamic range

Power:	$p_s \dots p_s / 10$ (100...10%)
Flow:	$q_s \dots q_s / 50$ (100.....2%)

4 Installation: 24 VAC

4.1 Installations diagram for MULTICAL® 601/602

NB: Below installation only relates to the 24 VAC Flow Controllers.

Installations chart for 24 VAC Flow Controller and 24 VAC valve motor:

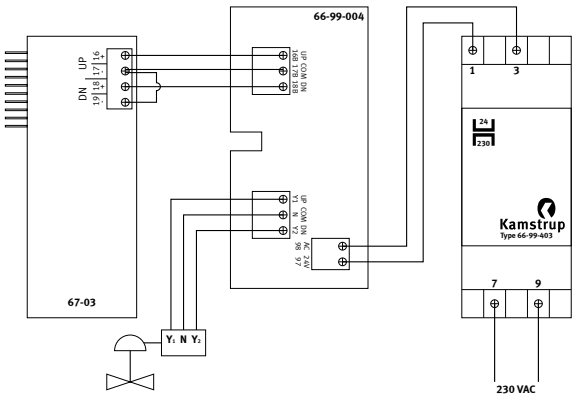

4.4 Installation principle

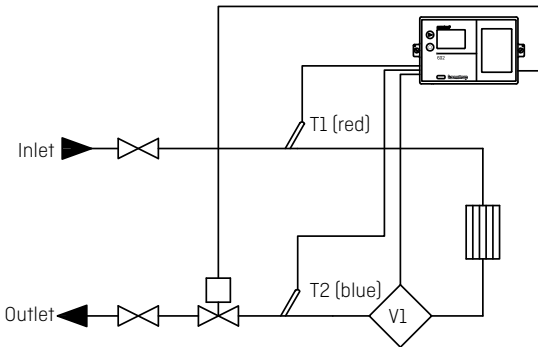

5 Operation

5.1 Operation by METERTOOL

To use the PQT-controller function the meter/top module must be programmed with the limit and valve parameters.

The programming is done by using METERTOOL HCW and optical readout head. All necessary data can be programmed without need of reverification.

Place the optical readout head at the MULTICAL® 601/602/801 and open the METERTOOL HCW program*. Activate "Modules" and select "Top module" and "PQ Limiter". Activate "Read" and readout the current limit and valve parameters.

* Select the correct COM port on the PC where the optical readout head is connected.

Meter settingsFlow meter q_p size:**General settings**Valve parameters
(Max flow = $2 \times q_p$):**PQ settings**

Limit data, flow and/or power:

Gain result in faster regulation, but
more overshooting.**Temperature settings**

Limit data, temperatures:

Hourly data logger

Reset "Hourly data logger"

PQ limiter

Meter settings
qp: 1.5 m³/h

General settings
Max flow: 3000 l/h
Total valve traction: 280 s
Hysteresis time: 500 ms
Special functions: 0

PQ settings
Flow limit: 800 l/h Deactivated
Power limit: 100.0 kW Deactivated
Gain factor (PQ): 150 %

Temperature settings
Min T1-T2 limit: 20.00 K Deactivated
Max T2 limit: 70.00 C Deactivated
Gain factor (T): 50 %
Flow cut off: 200 l/h

Hourly data logger
 Clear logger

"Deactivated" means that the function is not in operation.

Key in the changes required and activate "Configure" and the new data is transferred to the MULTICAL® 601/602/801 top module.

NB: When parameters (limits) are changed the controller assume the valve to be fully open.

This have no influence when parameters are reduced (lower), the control will continue normal operation.

If parameters are raised (higher) the result is a slow operation toward the new parameters.

This can be compensated by forcing the valve to its fully open position.

6 Trouble shooting

Symptom	Possible cause	Suggestion for correction
The motor valve remains totally closed and the "UP" light-emitting diode (LED) constantly lights.	The "UP" and "DOWN" connections have been switched.	Switch the connections.
The valve function is not working after reprogramming MULTICAL®.	During "Total programming with METERTOOL" the "PQT-Controller data" is deleted. Regulation parameters and valve data is only stored in the Top module 6703. The "PQT-Controller data" must be reprogrammed.	Enter new data by use of METERTOOL.
The motor valve responds too slowly in connection with flow or power peaks.	The regulating parameters do not fit the valve.	Enter new "PQT-Controller data" by means of METERTOOL. If the response is too slow the running time (Total Traction) typically must be raised.
The motor valve is unstable, does not stabilize.	The regulation parameters does not fit the valve.	Enter new "PQT-Controller data" by means of METERTOOL. When the valve is unstable the running time (Total Traction) must typically be reduced.
The "UP" and "DOWN" of the controller are functioning, but the valve is not running.	The valve is at a limit stop.	Adjust the motor valve limit stop (refer to valve documentation)
The "UP" and "DOWN" of the controller are functioning, but the valve is not reacting.	The controller is out of step due to changes in the parameter.	Re-set the controller by disconnecting the voltage to the controller for 30 sec. Check the voltages to the valve (perhaps the valve is defective).

Symptom	Possible cause	Suggestion for correction
The motor valve responds too slowly.	The working area is too low compared to the installation. E.g. if the limit should be set at 10% or less of the dynamic range.	Make sure that the installation is dimensioned correctly.
The motor valve responds too slowly (lack of accuracy).	Hysteresis is set too high, and thus the motor valve is not running so often (less wear) on account of the accuracy in the regulation.	Enter new hysteresis, in practice rarely more than 0.5-1 sec.

NB: Remember that in connection with closed valve motor, a minimum flow must be present to prevent frost bursts.

