

Kamstrup 9EVLP

Manual for Installation and Use

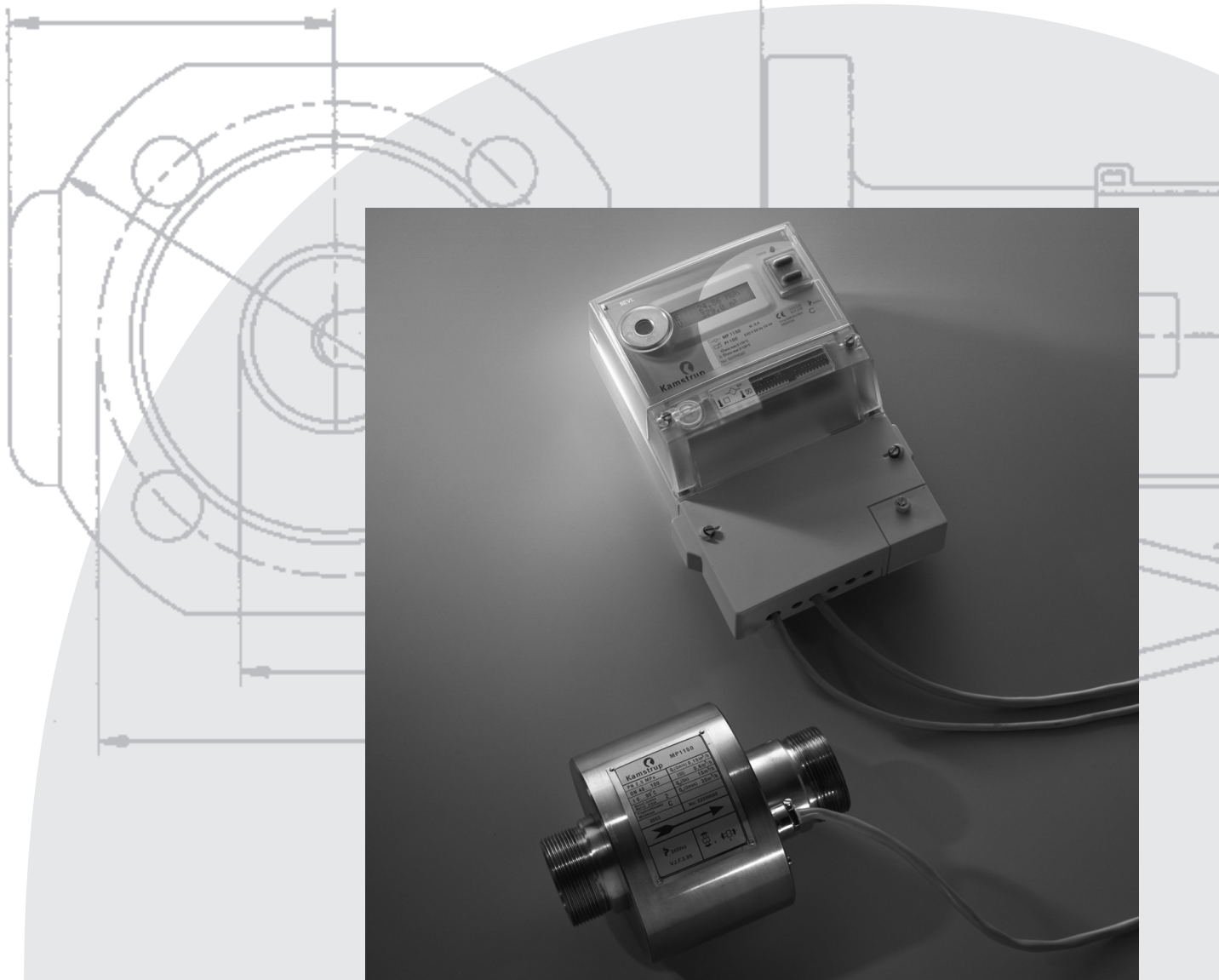

Kamstrup

Kamstrup A/S
Industrivej 28, Stilling
DK-8660 Skanderborg
TEL: +45 89 93 10 00
FAX: +45 89 93 10 01
E-MAIL: info@kamstrup.com
WEB: www.kamstrup.com

Contents

1. Introduction	5
1.1 Some 9EVLP features	5
2. System requirements	7
3. Installation	9
3.1 Installation from the Metertool for EVL CD to the hard disk	9
4. Languages	11
5. Online help	13
5.1 Welcome to Kamstrup 9EVLP Online Help!	13
6. Communications settings	15
6.1 Communications parameters	15
6.2 Modem commands	15
7. Modem connection and disconnection	17
7.1 Connection	17
7.2 Establishing connection between modems	17
7.3 Saving telephone numbers in Kamstrup 9EVLP Telephone catalogue	17
7.4 Disconnection	17
8. Reading data	19
9. Registers reading	21
9.1 Instantaneous registers	21
9.2 Peak registers	21
9.3 Cumulative registers	22
10. Testing	23
10.1 Temperature difference and energy measuring test	23
10.2 Flow measuring test	23
11. Programming	25
11.1 Editing parameters or making a new program	25
11.2 Loading programming parameters from 9EVLP.PRG file	25
11.3 Reading programming parameters from Kamstrup 9EVL meter	25
11.4 Writing programming parameters to Kamstrup 9EVL meter	26
12. Calibration	27
12.1 Reading calibration parameters from Kamstrup 9EVL meter	27
12.2 Specifying calibrating parameters to Kamstrup 9EVL meter	27
13. Troubleshooting	29
13.1 Communication error messages	29

1. Introduction

The Kamstrup 9EVLP is a Windows application. It is the user interface for 9EVL heat energy meters.

The Kamstrup 9EVLP executes the following functions for a 9EVL meter:

- Meter data reading.
- Register value reading.
- Parameter programming.
- Calibration.
- Flow measuring test.
- Temperature difference and energy measuring test.

1.1 Some 9EVLP features

The control bar speeds up the selection of commands. The hint text explains the purpose of each command.



Figure 1. Control bar and hint text area

A message field displays communication status.

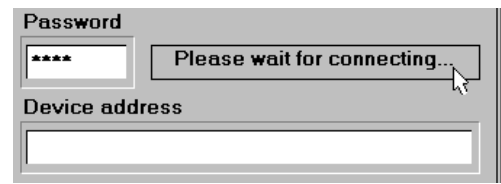

Figure 2. Message field

Message boxes contain warnings and other information.

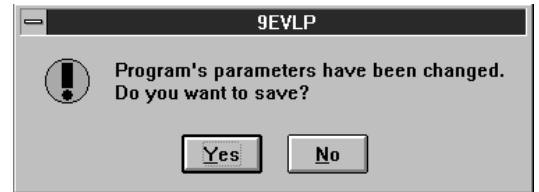

Figure 3. Message box that contains warning

The 9EVLP checks each input value and reports detected faults. This minimizes the number of input faults.

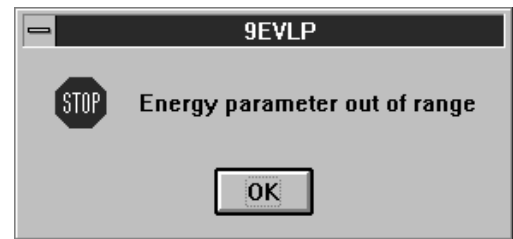

Figure 4. The 11EVLP reports invalid parameters

2. System requirements

Hardware and software requirements for the 9EVLP are as follows:

Operating system	Processor	Memory	Free hard disk	Serial port	Mouse
Windows 3.1, at least MS DOS v.5.0	386/486	2 MB	2 MB	RS232/RS485	Yes
Windows 3.11, at least MS DOS v.5.0	386/486	3 MB	2 MB	RS232/RS485	Yes
Windows 95	Pentium	8 MB	2 MB	RS232/RS485	Yes
Windows NT	Pentium	16 MB	2 MB	RS232/RS485	Yes
Windows 2000	Pentium	16 MB	4 MB	RS232/RS485	Yes

It is recommended to enable printing through Windows.

3. Installation

This instruction applies both to first installations and version updates.

The Kamstrup Metertool for EVL programs are supplied on one CD, which also contains the operating manuals of the programs. In addition, you need an optical serial cable (opto-cable), which enables the communication between the PC and the units. You can also use a modem connected to the PC, which communicates with the unit via telephone network.

3.1 Installation from the Metertool for EVL CD to the hard disk

To install the programs, place the CD in the CD-ROM drive of your computer.

If the program does not start automatically, run the **setup.exe** program on the CD.

On-screen instructions will then guide the rest of the installation.

3.2 Windows 2000

In Windows 2000, following selection may be required:

1. Before you start a Metertool EVL program, right-click the icon of the program
2. Select **Properties**
3. Select the tab **Shortcut**
4. Tick the **Run in a Separate Memory Space** box
5. Choose **OK**

4. Languages

The Kamstrup 9EVLV has three command languages. The language can be changed when the program is running.



Figure 7. Language command

Do the following to change the language:

1. Choose the *Language...* command from the *Settings* menu.
2. Choose the desired language.
3. Click the *OK* button.

That language is now the default language when the application is run the next time.

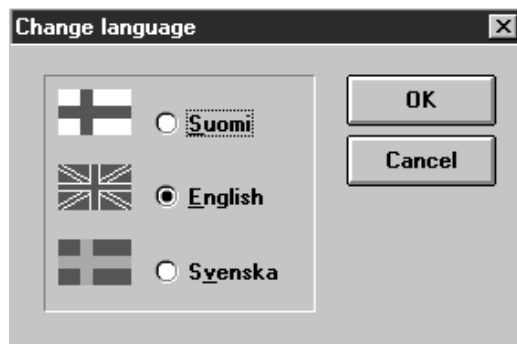

Figure 8. Three languages of the Kamstrup 9EVLV

5. Online help

Choose the *Contents* command from the *Help menu* to use the Online Help.



Figure 9. Contents command

Next, select the 9EVLP application from the list:

- 9EVLP
- 10EVLP
- Kamstrup 11EVLP
- 9VP
- EVLS

After this, you can read additional information on any of the following topics:

5.1 Welcome to Kamstrup 9EVLP Online Help!

- Language settings
- Communications settings
- Modem connection and disconnection
- Reading data from a meter
- Reading instantaneous registers
- Reading peak registers
- Reading cumulative registers
- Flow testing
- Temperature and energy testing
- Programming
- Calibration

The Online help can also be opened by clicking the *Help* button in dialog boxes.

6. Communications settings

Communications settings and modem initialization parameters are specified using the *Communication* command from the Settings menu.



Figure 10. Communication command

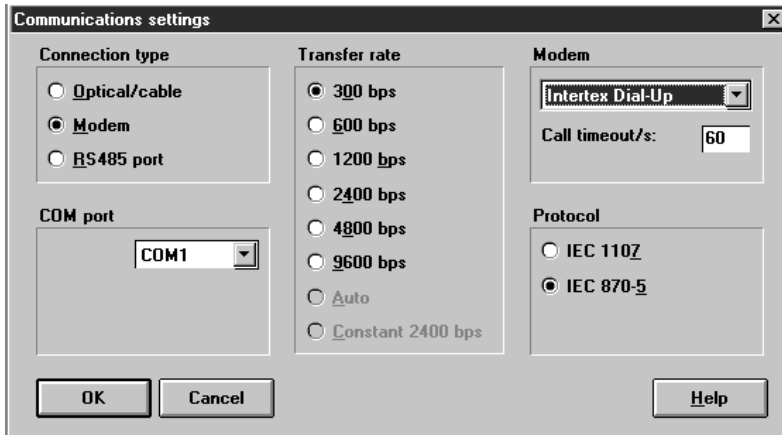

Figure 11. Communications settings dialog box

6.1 Communications parameters

There are two ways to communicate with a Kamstrup 9EVL meter depending on the connection type.

- *Optical/Cable* option using the IEC 1107 protocol: Communication speed can be chosen between 300 bps and 9600 bps depending on the communication speed programmed to the meter. Choose *Auto* as the communication speed. For example, using the *300 bps* option you can force the meter to 300 bps speed. If the meter has only 2400 bps speed, the *Constant 2400 bps* is the only option available.

- *Modem* option using the IEC 1107 protocol: The communication speed can be either 300 bps or constant 2400 bps. The latter speed is available only if the *Constant 2400 bps* parameter of the meter is in use.

If the IEC 870-5 protocol (M-Bus) is in use, communication speed can be chosen between 300 bps and 9600 bps depending on the communication speed of the IEC 870-5 protocol programmed to the meter. However, the speed cannot be *Auto* or *Constant 2400 bps*.

Note!

If the IEC 870-5 protocol (M-Bus) is in use, the modem must support 11 bit character length.

- The *RS485 port* option allows you to choose RS485 serial port as the communications setting. It is a separate card in the PC.

Specifying communications parameters

1. Choose *Communication* command from the Settings menu.
2. Specify the connection type. If you chose the modem, choose also the modem type in the Modem menu. If the modem you use is not in the menu, choose the *Default* option.
3. Choose the *protocol*.
4. Choose the *communication speed*.
5. Choose a serial port COM1 ... COM4.
6. Click the *OK* button.

Hint

If the communication speed of the meter is not known, choose the *Auto* option. Then the PC communicates at the speed programmed to the meter, unless the *Constant 2400* option has been chosen.

Example

In the following, the communication speed is changed from 2400 bps to 9600 bps using the *Optical/Cable* connection and the IEC 870-5 protocol.

1. Open the *Programming* dialog box from the *Operations* menu.
2. Choose *Settings*. In the *Communications settings* dialog box, choose the current communication speed 2400 bps (see *Hint* above). Click the *OK* button.
3. Type the meter password in the *Password* field. Click the *Read* button to read the meter programming parameters.
4. After successful reading, check the *Communication* checkbox. Click the *Edit* button to open the *Communication* dialog box.
5. Choose *9600 bps* as the IEC 1107 protocol speed. Click the *OK* button.
6. Click the *Write* button.
7. After successful writing, open the *Communications settings* dialog box. Choose *9600 bps* as the communication speed. Click the *OK* button.

6.2 Modem commands

The modem commands have two parameters:

- *Modem type*: Choose the modem you use.
- *Call timeout*: Specify the time that the modem waits for a response. Default call timeout is 60 seconds.

Note!

The modem commands can be modified also by using a text editor program. Open the *MODEMS.INI* file in the *ENETOOLS* directory, and make the required changes.

7. Modem connection and disconnection

In remote reading, a connection between two modems is made using the telephone network. When the meter connection is no longer required, it can be terminated. Then the telephone line is free for other use.

7.1 Connection

If the connection type in *Communications settings* is *Modem*, the Kamstrup 9EVLP activates *Connect* command from the *Modem* menu.

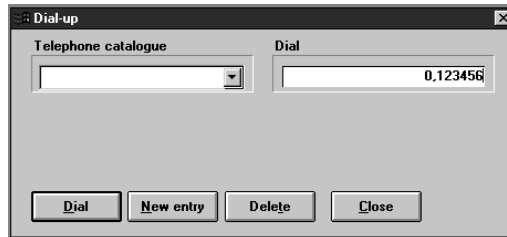

Figure 12. Dial-up dialog box

7.2 Establishing connection between modems

1. Choose *Modem* as the connection type in the *Communications settings* dialog box. It activates the *Connect* command from the *Modem* menu.
2. Choose *Connect* from the *Modem* menu.
3. Type the remote telephone number in the *Dial* field or choose the number from the Telephone catalogue.
4. Click the *Dial* button. Wait until the Kamstrup 9EVLP has established the connection. If the connection is established, the Kamstrup 9EVLP closes the *Dial-up* dialog box automatically.

7.3 Saving telephone numbers in Kamstrup 9EVLP Telephone catalogue

1. Choose *New entry*.
2. Type name and number to the proper fields.
3. Click the *Save* button.

7.4 Disconnection

When you no longer need to communicate with the meter, terminate the connection by choosing the *Disconnection* command. Wait for a few seconds. After disconnecting, the Kamstrup 9EVLP activates the *Connection* command and disables the *Disconnection* command.

8. Reading data

The data from the meter can be read by choosing the *Reading* command from the *Operations* menu.

The data can be copied to other Windows applications or saved in text format using the *Reading data* dialog box. Then the file can later be used in most text editor programs or even in Microsoft Excel.

Reading data from Kamstrup 9EVL meter

1. Choose *Reading* from the *Operations* menu.
2. Choose the type of meter that is read.
3. Type the device address, if necessary.
4. Choose the reading mode:
 - Data readout
 - History data (10EVL)
 - Extended data readout
 - Tariff data readout
 - M-Bus reading
5. Click the *Read* button.

Note!

If the meter's M-Bus list is read without an IEC 870-5 card, the meter communications protocol must be specified using the meter's push buttons. Choose IEC 870-5 as the protocol for the Kamstrup 9EVL program. Then set the proper communication speed. Note that Auto or Constant 2400 bps options are not available in the M-Bus protocol.

The meter readings are displayed in a separate WordPad document. They can then be copied to Windows clipboard and moved to other Windows applications.

The reading data can be saved in file format using the commands in the *File* menu. The recommended file name extension is ".DAT". When a file is saved or opened, the Kamstrup 9EVL lists all existing data files.

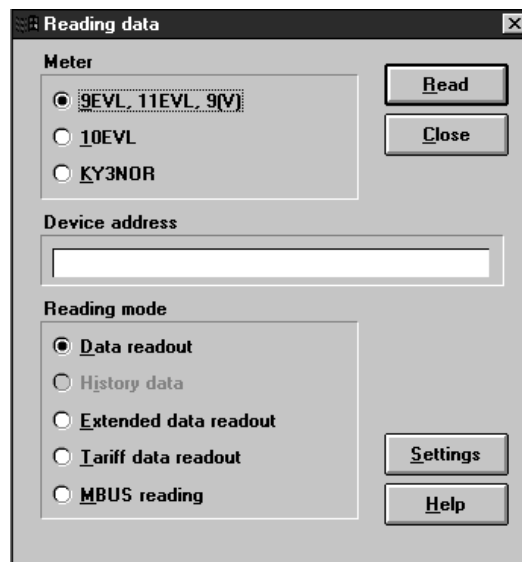

Figure 13. Data readout in Reading data dialog box

9. Registers reading

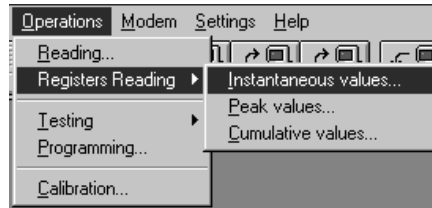

Figure 14. Registers reading command

A Kamstrup 9EVL meter has the following kinds of data registers:

- Instantaneous registers
- Peak registers
- Cumulative registers

The *Registers Reading* command is used to read or reset register values.

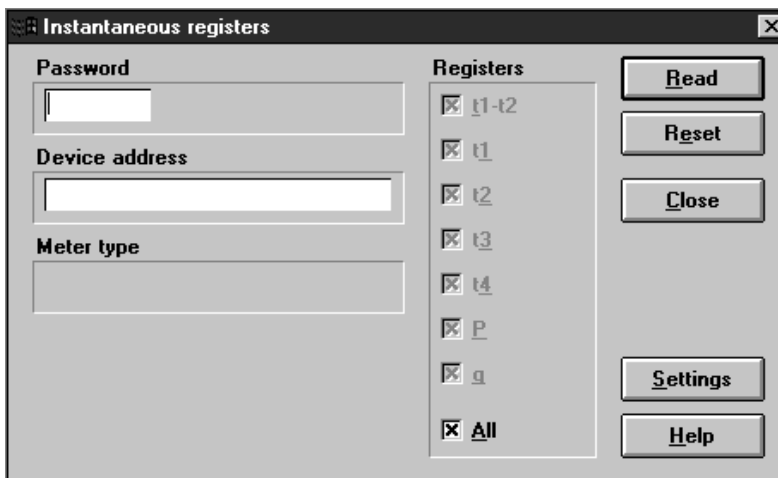

Figure 15. Instantaneous registers dialog box

9.1 Instantaneous registers

Reading of instantaneous registers

1. Choose *Registers Reading* from the *Operations* menu.
2. Choose *Instantaneous values* from the *popup* menu.
3. If you do not want to read all the registers, uncheck the *All* checkbox. Then select the registers you want to read.
4. Type the password and, if necessary, the device address.
5. Click the *Read* button.
6. You can copy the values of instantaneous registers to Windows clipboard by selecting the values you want to copy from the separate WordPad document. Choose the *Copy* command from the *Edit* menu. To save the values, choose the *Save as* command from the *File* menu. Give the file a name with the recommended file name extension ".DAT".

Resetting of instantaneous registers

1. Choose *Registers Reading* from the *Operations* menu.
2. Choose *Instantaneous values* from the *popup* menu.
3. Type the password and, if necessary, the device address.
4. Click the *Reset* button.

Note!

The *Reset* command resets all the registers, not only the selected ones.

9.2 Peak registers

Reading of peak registers

1. Choose *Registers Reading* from the *Operations* menu.
2. Choose *Peak values* from the *popup* menu.
3. If you do not want to read all the registers, uncheck the *All* checkbox. Then select the registers you want to read.
4. Type the password and, if necessary, the device address.
5. Click the *Read* button.
6. You can copy the values of peak registers to Windows clipboard by selecting the values you want to copy from the separate WordPad document. Choose the *Copy* command from the *Edit* menu. To save the values, choose the *Save as* command from the *File* menu. Give the file a name with the recommended file name extension ".DAT".

Resetting of peak registers

1. Choose *Registers Reading* from the *Operations* menu.
2. Choose *Peak values* from the *popup* menu.
3. Type the password and, if necessary, the device address.
4. Click the *Reset* button.

Note!

The *Reset* command resets all the registers, not only the selected ones.

You need a programmer access level to the Kamstrup 9EVL meter to reset the peak registers.

9.3 Cumulative registers

Reading of cumulative registers

1. Choose *Registers Reading* from the *Operations* menu.
2. Choose *Cumulative values* from the *popup* menu.
3. If you do not want to read all the registers, uncheck the *All* checkbox. Then select the registers you want to read.
4. Type the password and, if necessary, the device address.
5. Click the *Read* button.
6. You can copy the values of cumulative registers to Windows clipboard by selecting the values you want to copy from the separate WordPad document. Choose the *Copy* command from the *Edit* menu. To save the values, choose the *Save as* command from the *File* menu. Give the file a name with the recommended file name extension “.DAT”.

Resetting of cumulative registers

1. Choose *Registers Reading* from the *Operations* menu.
2. Choose *Cumulative values* from the *popup* menu.
3. Type the password and, if necessary, the device address.
4. Click the *Reset* button.

Note!

The Reset command resets all the registers, not only the selected ones.

You need an adjuster access level to the Kamstrup 9EVL meter to reset the peak registers.

10. Testing

10.1 Temperature difference and energy measuring test

Temperature and Energy command sets the meter to two alternative test modes. The testing is done via serial bus.

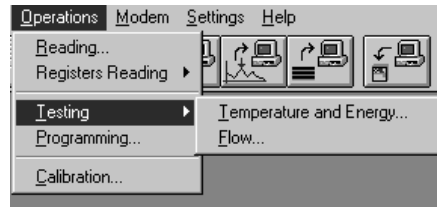

Figure 16. Testing command

Choose *Temperature and Energy* from the *Testing* popup menu of the *Operations* menu.

Temperature difference and energy measuring test

1. Choose *Temperature and Energy* from the *Testing* menu.
2. Choose the test mode.
 - *Manual*: In this mode, the user must feed the volume pulses manually using the test connector. This is done by using the buttons on the meter. The test register values are cumulative.
 - *Automatic*: In this mode, the 9EVL meter generates the test pulses automatically. The test register values are averaged per pulse.
3. Type the password and, if necessary, the device address.
4. Click the *Connect* button to establish the connection to the meter.
5. Click the *Start* button to start the testing.
6. Click the *Stop* button to stop the testing.
7. Click the *Disconnect* button to terminate the connection to the meter.

Note!

When establishing the connection, the meter type is defined automatically. The meter type determines the number of decimals in the test registers.

When terminating the connection using the *Disconnect* button, the 9EVL program asks whether to leave the meter in the test mode or set it back to the normal mode. Click *No* in the message box to set the meter to the normal mode. If the message box is closed without terminating the connection, the meter remains in the test mode. If this happens unintentionally, reopen the testing dialog box, establish the connection and terminate it using the *Disconnect* button.

10.2 Flow measuring test

The *Flow* command sets the meter to a mode, in which the flow measuring test can be done via serial bus.

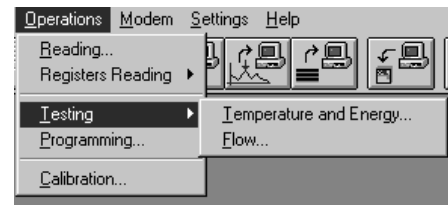

Figure 17. Flow command

Choose *Flow* from the *Testing* popup menu of the *Operations* menu.

Flow measuring test

1. Choose *Flow* from the *Testing* menu.
2. Type the password and, if necessary, the device address.
3. Click the *Connect* button to establish the connection to the meter.
4. Click the *Start* button to start the testing.
5. Click the *Stop* button to stop the testing.
6. The reference tank volume can be given either as *Volume* or *Mass*. When you click the *Calculate error* button, the program calculates the error percentage of the test register. The error percentage can be used directly in calibrating the meter.
7. Click the *Disconnect* button or close the dialog box to terminate the connection to the meter.

11. Programming

The Kamstrup 9EVLP can be used to program all parameters for the meter.

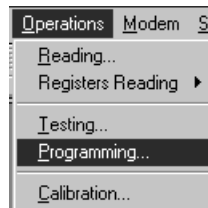

Figure 18. Programming command

Choose the *Programming* command from the *Operations* menu.

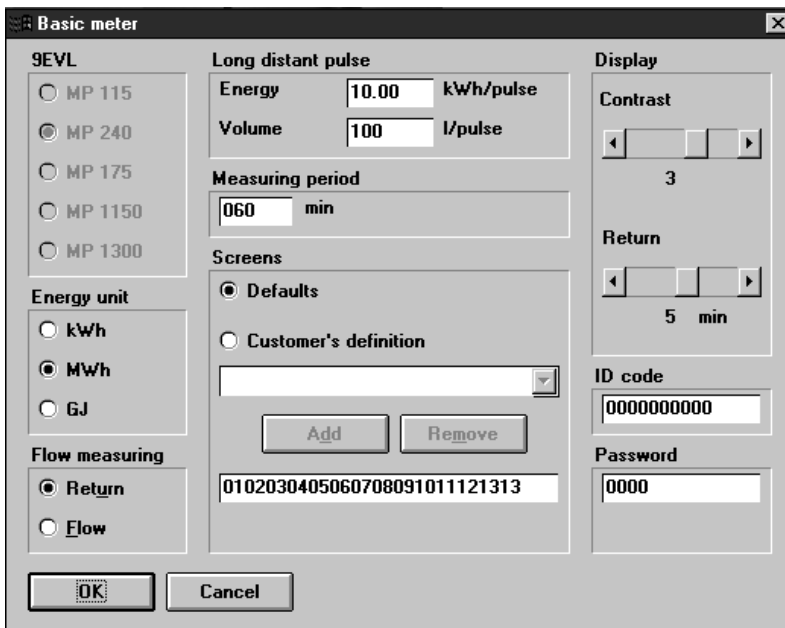

Figure 19. The program form for Basic meter

11.1 Editing parameters or making a new program

1. Choose *Programming* from the *Operations* menu.
2. Type the password and, if necessary, the device address.
3. Choose the program form:
 - *Basic meter*
 - *Communication*
 - *Tariff*
4. Click the proper button (*New* or *Edit*) and fill in the form.
 - If you click the *New* button, the program displays all the program forms starting with the *Basic meter* form. All the forms are empty.
 - If you click the *Edit* button, the program displays the program form, which was selected in the *Program form* section.

- If there is a tariff card attached to the meter, the tariff card option should be turned on. If the meter has no tariff card, the option should be turned off. This prevents sending unnecessary tariff commands to the meter.

5. Accept the new parameters by clicking the *OK* button.
6. If you want to save the parameters to disk, type a new name to the *Program list* field. Then click the *Save* button.

Hint

You can make a new program more easily if you choose, in the *Program* form, the *MP 115/240* option for small pipes and the *MP 175/1150/1300* option for large pipes. Then load the factory parameters by choosing the *Defaults* option. After this, you can modify the parameters by selecting the program form and clicking the *Edit* button.

11.2 Loading programming parameters from 9EVLP.PRG file

1. Choose *Programming* from the *Operations* menu.
2. Choose the program name from the *Program list* menu.
3. Click the *Open* button. The title bar of the program form displays the program's name, date and time of saving.

11.3 Reading programming parameters from Kamstrup 9EVL meter

1. Choose *Programming* from the *Operations* menu.
2. Type the password and, if necessary, the device address.
3. If there is a tariff card attached to the meter, the tariff card option should be turned on. If the meter has no tariff card, the option should be turned off. This prevents sending unnecessary tariff commands to the meter.
4. Click the *Read* button. Check if all the parameters are read successfully.

After successful reading, the message field displays "*Done!*" and the title bar displays "*Read from the meter*".

11.4 Writing programming parameters to Kamstrup 9EVL meter

1. Choose *Programming* from the *Operations* menu.
2. Make a new program or load a program from the *Program* list menu.
3. If there is a tariff card attached to the meter, the tariff card option should be turned on. If the meter has no tariff card, the option should be turned off. This prevents sending unnecessary tariff commands to the meter.
4. Type the password and, if necessary, the device address.
5. Click the *Write* button. Check if all the parameters are written successfully.

Note!

Programming requires a programmer access level to the meter.

If you feed programming parameters, which have just been read from the meter, only the modified parameters are written back to the meter. You can force the Kamstrup 9EVL program to write all the parameters by checking the All commands checkbox.

If you want to reset the peak and cumulative registers after the programming, check the Reset registers checkbox.

Important!

When programming the transmitting period and/or the tariff measuring period of a tariff card meter, the meter clears all previously collected data. Before the 9EVL writes these parameters, it warns about clearing the collected data and asks if the user wants to skip the command. The user has the following three options:



Yes

The programming is completed without clearing the tariff data.

No

The parameters are programmed and the tariff data is cleared.

Cancel

The programming is canceled.

12. Calibration

The Kamstrup 9EVL is used to calibrate the parameters of flow and temperature measuring and also define the meter type.

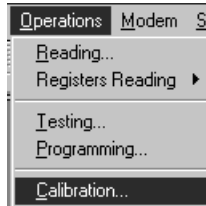

Figure 19. Calibration command

Choose the *Calibration* command from the Operations menu.

12.1 Reading calibration parameters from Kamstrup 9EVL meter

1. Choose the *Calibration* command from the Operations menu.
2. Type the password and, if necessary, the device address.
3. Click the *Read* button.

12.2 Specifying calibrating parameters to Kamstrup 9EVL meter

1. Choose the *Calibration* command from the Operations menu.
2. Type the calibrating parameters to the proper fields. Choose the meter type.
 - The program automatically inserts the last error percentage either to q_{min} error or q_n error field, if you check the respective option in the *Error percentage (from testing)* checkbox (see the “Flow measuring test” chapter for information on using the Error percentage).
 - The safest way to specify the calibrating parameters is first to read the parameters from the meter and then to modify them, if necessary.
3. Type the password and, if necessary, the device address.
4. Click the *Write* button.

Note!

Calibrating the Kamstrup 9EVL requires an adjuster access level to the meter.

All unspecified calibrating parameters are ignored when writing to the meter.

13. Troubleshooting

13.1 Communication error messages

Message

Can't make connection

Description

The 9EVLP could not establish a connection to the meter.

Solution

Check the communication failure message box. Fix the problem.

Message

Communication failed

Description

The 9EVLP established a connection to the meter, but failed to communicate with it.

Solution

Check the communication failure message box. Fix the problem.

Message

Password missing

Description

All register reading, programming, testing and calibrating operations require the meter password to access the programming level.

Solution

Type the meter password in the Password field and retry.

Message

Time-out

Description

The meter has not responded within the time limit.

Solution

Check the connecting cable and other communications settings.

Message

Unknown password

Description

The meter rejected an incorrect password.

Solution

- Type the correct password and retry.
- If this message occurs, when you are using the RS485 card and a high communication speed (2400 bps-9600 bps), retry using the 300 bps speed.

Message

BCC error

Description

Sent data was invalid (was not in accordance with the IEC 1107 protocol).

Solution

Retry several times.

Message

Description

Check sum error

Sent data was invalid (was not in accordance with the IEC 870-5 protocol).

Solution

Retry several times.

Message

Description

Communication error

- The program could not set communication parameters.

- The COM port chosen in the Communications settings dialog box may not be available.

Solution

- Select another COM port and retry.

- If the error persists, close the program and run it again.

- Check the system serial port by running the MSD.EXE program supplied with Windows 3.x. It tells you if your PC supports the chosen COM port. The program is also available on the Windows 95 Install CD.

Message

Description

COM port is not open

You tried to close the COM port or send data when the COM port was not open.

Solution

Click the *OK* button and try again.

Message

Description

COM port is already open

The COM port chosen in the Communications settings dialog box is probably used by another program.

Solution

- Choose another COM port or close the program that is using the port. Retry.

- If this error occurs when there are no other communication programs running, close the 9EVLP and run it again.

Message	<i>Modem connection error</i>	Message	<i>Data failure xx</i>
Description	An attempt to make a connection using a modem has failed.	Description	You have tried to program an unspecified parameter to the program.
Solution	<ul style="list-style-type: none"> - Check that the remote modem is on-line and in the answering mode. - Check that the modem initialization parameters and the call time-out defined in the Communications settings dialog box are in accordance with the modem settings. - Check that the telephone line is connected properly. 	Solution	Check the parameters and retry.
Message	<i>Can't allocate memory to buffer data</i>	Message	<i>Access denied</i>
Description	The 9EVLP could not allocate memory to buffer incoming data.	Description	You have tried to edit a protected parameter.
Solution	Check the PC free memory. If there are too many programs running, close them.	Solution	<ul style="list-style-type: none"> - This is a security method, which protects the meter from accidental parameter changes. Check that you have the authority to change the programming/security access parameters before changing them. - A programmer access level is required for programming parameters and resetting peak registers. - An adjuster access level is required for calibrating and resetting cumulative registers.
Message	<i>Can't write to the modem</i>	Message	<i>Invalid command</i>
Description	The 9EVLP could not send initialization parameters to the modem.	Description	<ul style="list-style-type: none"> - The meter has received an invalid command number. - The program sends only approved commands. However, interference during communication may have changed the command number.
Solution	<ul style="list-style-type: none"> - Check the connecting cable between the modem and the PC. - Check that the chosen COM port is correct for the modem. - Check that the initialization parameters and the call timeout defined in the Communications settings dialog box are in accordance with the modem settings. 	Solution	Retry using a lower communication speed.
Message	<i>Can't read all incoming data</i>	Message	<i>Missing unit</i>
Description	The program failed to receive all incoming data.	Description	You have tried to read a meter, which has no tariff or temperature card attached.
Solution	<ul style="list-style-type: none"> - If there are too many programs running, close some of them. - Make sure that the connecting cable is not exposed to a strong magnetic field. - Retry with the lowest communication speed (300 bps). 	Solution	When you program a meter that does not have a tariff card, uncheck the Tariff card checkbox in the program form.

