

## Leak monitoring & Leak protection

- Environmental and economical advantage
- Approved heat metering
- Approved cooling metering
- Metering with antifreeze additives
- Insurance approved leakage protection in Denmark

RECOMMENDED BY DANISH  
TECHNOLOGICAL INSTITUTE



LEAK PROTECTION  
SERVICE



LEAK MONITORING  
REMOTE READING



TYPE APPROVED  
BILLING METERS



2020

## Contents

Monitoring that pays off	3
Leak monitoring or leak protection – what do you get?	4
OptiTight® Leak Detection by DanTaet	5
Leak monitoring	6
Basic principles of leak monitoring	7
Proven technology	7
Historical data provide important information	7
Which heat meters can carry out leak monitoring?	8
Meter functionality	9
Leak protection	10
Leak protection for commercial installations	11
Cooling	12
Cooling circuit leakage protection	13
Wide application range	14
Permanent Operation Monitoring (POM)	15

# Monitoring that pays off

Environmental protection does not have to cost extra.

Kamstrup's leak monitoring with MULTICAL® can detect leaks in both heating, cooling and cold water systems.

The monitoring enables you to reduce boiler feed water and discover leaks in installations for domestic water.

At the same time, the system reveals if raw water is being added. It is good for the environment and for the economy.

Most Danish insurance companies offer their consumers [discounts on the burst pipe insurance](#) when leak monitoring is supplemented with leak protection from DanTaet. Please contact your insurance company for further information.



# Leak monitoring or leak protection – what do you get?

Kamstrup Leak Monitoring	DanTaet Leak Protection
The installed Kamstrup meter <b>monitors</b> the consumption pattern and detects a possible leak in the heating installation, the calorifier or the heat exchanger. The meter <b>advises</b> the utility of the leak via remote communication.	Leak Protection <b>monitors</b> , <b>advises</b> and <b>stops</b> leaks from the heating/cooling installation by <b>raising an alarm and shutting</b> the system's cut-off valves.
The system <b>reduces feed water requirement</b> at the utility, thereby reducing the cost of heat distribution.	Leak protection monitors flow differences using <b>higher sensitivity</b> than leak monitoring. The solution is <b>fully automatic</b> , requiring no manual intervention.
The solution is a <b>service</b> by the utility for the consumer in the shape of a notification of leak from the heating installation. The advisement depends on a remote reading indicating the leak and thus depends on the utility's meter reading frequency and event handling.	OptiTight performs a <b>regular tightness check</b> of the installation. The system detects seepages in order of magnitude smaller than those detectable by leak monitoring. The solution further performs self-checking of attached components.
	Insurance companies offer a <b>premium discount</b> when leak protection that limits water damage is installed.

Leak monitoring may be extended into leak protection adapted to the actual application so that the heating and supply water installations are immediately cut off upon leakage. Thus, leak protection is a refinement of leak monitoring using other leak detection mechanisms as well as cut-off valves for isolating the installation from the supply in the event of seepage or pipe fracture.

Leak monitoring

Leak protection

Leak monitoring

	MULTICAL® Leak monitoring	DanTaet System KMP-F/KMP-K Leak protection with MULTICAL®
Leak Monitoring	✓	✓
Pipe Burst Alarm	✓	✓
Mass Comparison	✓	
Flow Comparison		✓
Leak Protection, Valve Cut-off		✓
Tightness Check OptiTight® (via Valve Cut-off)		✓
Alarm Relays		2
Digital Outputs		3
Digital Inputs		2
Liquid Sensor Attachment		2
Ext. OptiTight® Trigger		✓
Drain Valve		Option
Operating Pressure Monitor		Option

# OptiTight® Leak Detection by DanTaet

	MULTICAL® Leak monitoring	DanTaet System KMP-F/KMP-K Leak protection with MULTICAL®
<b>Burst "fast response"</b>		
Sensitivity	20 % of $q_p$	2 % of $q_p$ + 2 % of $q$ (factory setting)
Response time	4 minutes	2-7 minutes depending on size of leak
Reaction	Data for Utility, which may notify consumer if agreed upon	Local alarm, may be attached to Text Alarm transmitter or DanTaet AERS
Installation Cut-off	No	Yes, automatic
<b>Monitoring "continuous"</b>		
Sensitivity	1 % of $q_p$ + 10 % of $q$ (factory setting)	2 % of $q_p$ + 2 % of $q$ (factory setting)
Response time	24 hours	2-7 minutes depending on size of leak
Reaction	Data for Utility, which may notify consumer if agreed upon	Local alarm, may be attached to Text Alarm transmitter or DanTaet AERS
Installation Cut-off	No	Yes, automatic
<b>Seepage "high sensitivity"</b>		
Sensitivity		0,2 % of $q_p$
Response time		24 hours (depends on setting)
Reaction		Local alarm, may be attached to Text Alarm transmitter or DanTaet AERS
Installation Cut-off		Yes, automatic

Kamstrup Leak Monitoring

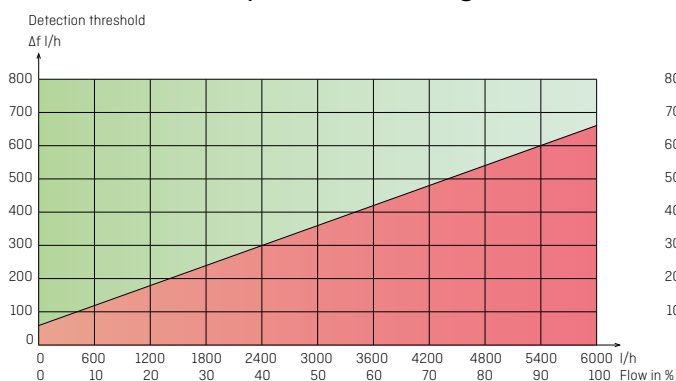

DanTaet OptiTight® Leak Detection

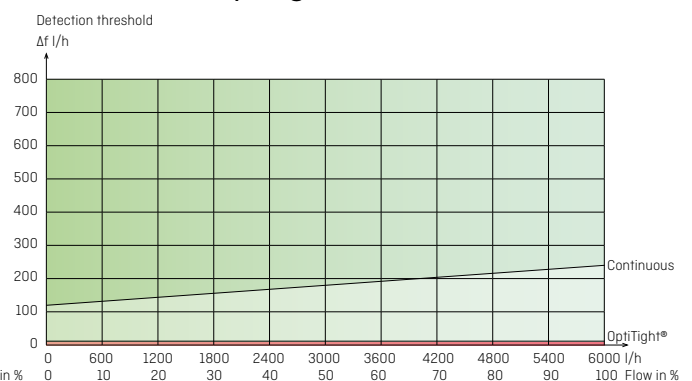

Kamstrup Leak Monitoring primarily detects pipe bursts and running leaks.

For additional detection of and protection from minimal and seeping leaks, OptiTight® by DanTaet is the obvious choice. OptiTight® features high sensitivity and may even detect leaks smaller than the meter cutoff (minimal indication of the meter).

The above graphs illustrate the seepage detection capabilities of Kamstrup Leak Monitoring and DanTaet OptiTight®, respectively, using a 6.0 m<sup>3</sup>/h flow meter.

# Leak monitoring



Leakage monitoring with MULTICAL® is entirely based on [comparisons between the two flow meters](#) in an installation. It is the ideal and most cost-effective solution for all private consumers of a heat utility.

The installation does not comprise cut-off valves or require any operation from the private consumers.

The additional cost compared to an ordinary district heating meter is minimal, and at the same time, both the heat utility and the private consumer gain a large number of advantages.

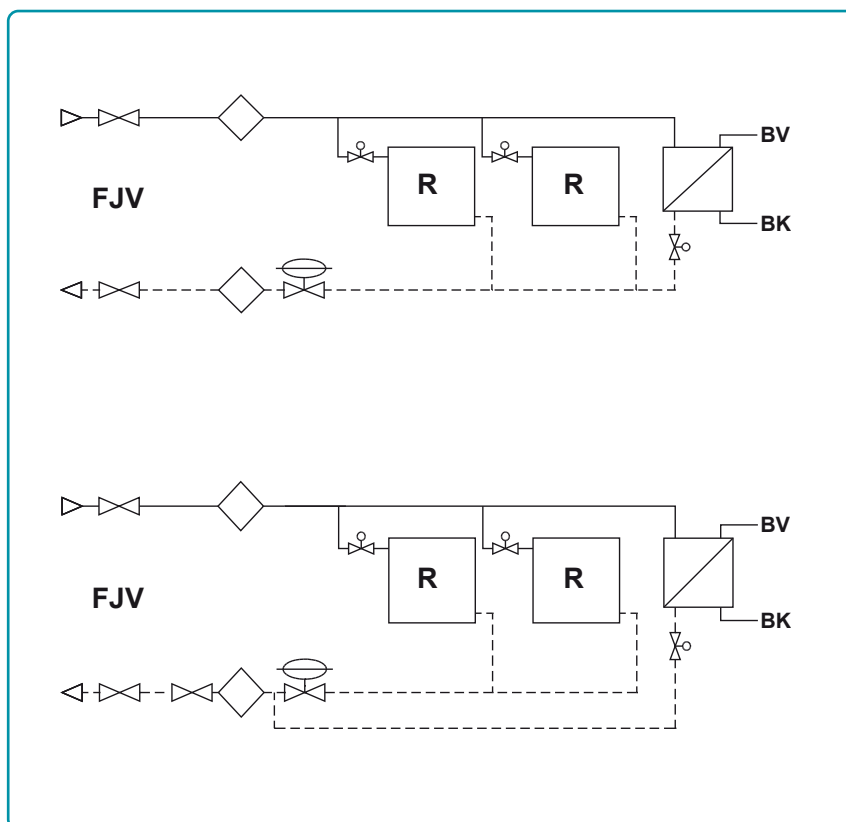

# Basic principles of leak monitoring

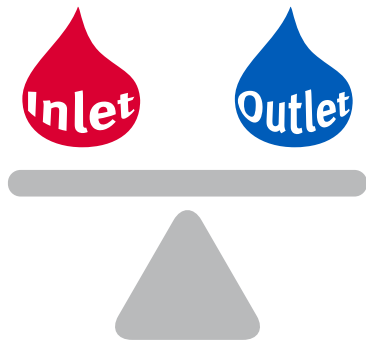

Leak monitoring of a heating system is based on a comparison of the inlet and outlet flows. Volume flow is converted to mass flow, making the leak monitoring independent of the water temperatures. If the meter detects an imbalance between the inlet and outlet flow masses, it sends an alarm notification via the remote reading system to the central system.

By leak monitoring of domestic water systems, [the meter monitors the consumption pattern](#).

If the meter does not stand still for a predefined period of time each day, it sends an alarm notification via the remote reading system to the central system.

## Proven technology

Since 2001, leak monitoring from Kamstrup has been installed in meters of a large number of district heating consumers, and their [experience](#) speaks for itself. Please contact us for further information and references.

In addition, MULTICAL® is [tested](#) at the Danish Technological Institute. The test report is available from Kamstrup upon request.

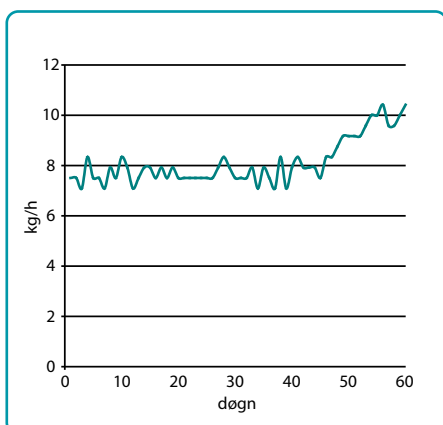

## Historical data provide important information

MULTICAL® contains a [permanent memory](#) with all relevant data on a daily basis, among other things. This data shows you how the leak has developed in the period just before the time of the alarm.

With the PC program LogView, you can read all relevant operational data directly from the data logger in MULTICAL®. This includes energy, volume, mass, temperatures and information codes.

# Which heat meters can carry out leak monitoring?

MULTICAL® 66-C



MULTICAL® 601



MULTICAL® 602



MULTICAL® 801



The meters must be installed with

- ➔ Two identical flow meters for leak monitoring
- ➔ Two temperature sensors (three in case of Permanent Operation Monitoring – POM)
- ➔ Remote reading

MULTICAL® 603



MULTICAL® 803



# Meter functionality



Leak protection with DanTaet KMP-F/KMP-K		✓	✓
Leak Monitoring		✓	✓
Pipe Burst Alarm		✓	
Mass Comparison		✓	
MID-approved heat meter	✓	✓	*)
TS27.02-approved cooling meter	✓	✓	*)
TS27.02-approved heat/cooling meter	✓	✓	
Ultrasonic flow meters	✓	✓	
Magnetic or mechanical flow meters		✓	✓
Metering solely for pure water media	✓	✓	
Metering for mixed media			✓
DanTaet Leak Alarm in INFO code		✓	✓

\*) No protocol exists for the approval of heat or cooling meters for mixed media.

# Leak protection



DanTaet System KMP-F is a leak protection solution receiving metering data via a serial data connection to MULTICAL® 601, MULTICAL® 602, MULTICAL® 603, MULTICAL® 603-M, MULTICAL® 801, MULTICAL® 803 or MULTICAL® 803-M. The system controls cut-off valves, performs the patented OptiTight® tightness test and handles pockets of air in the installation (Air Lock Handling). The continuous monitoring ensures high sensitivity and fast response to leaks.

The DanTaet KMP-F system can be used together with all existing MULTICAL® leak monitoring solutions except MULTICAL® 66-C.

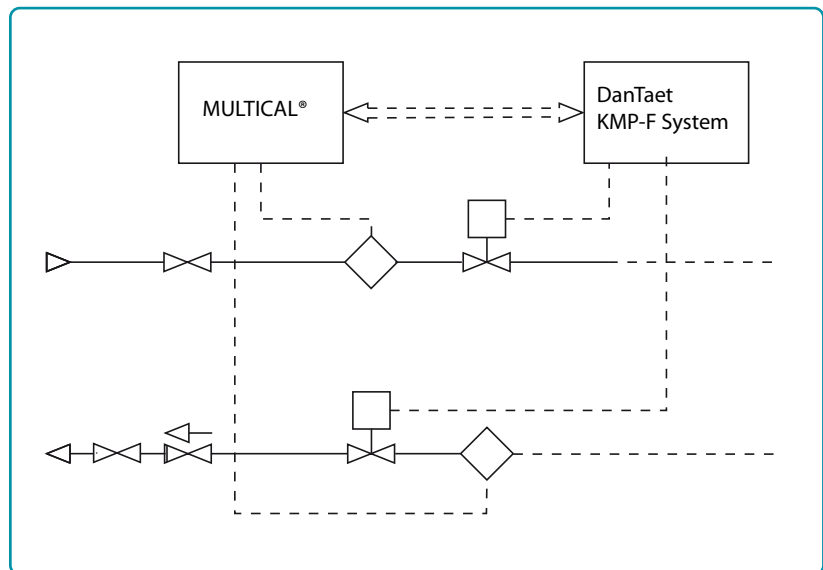

# Leak protection for commercial installations

DanTaet leak protection for industrial installations is the individual leak protection for larger installations and/or for installations with special demands.

The system can be tailored with multiple features via digital inputs and outputs. Operating pressure monitoring and frost protection of outdoor convectors can also be handled by the system.

DanTaet commercial installations are set up and put into operation by DanTaet's technicians so that the installation is optimised for the actual district heating installation. The systems come with two years of free service.



## SMS alarm

This is connected to the KMP-F alarm output and sends a text message to one or more mobile numbers on alarm.



## Outdoor temperature sensor

Deselects OptiTight® in cold weather, protects ventilation heating surfaces.



## Drain valve

This is employed in critical applications for draining the district heating installation on leak alarm.

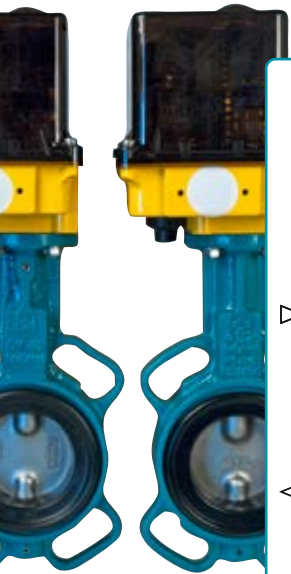
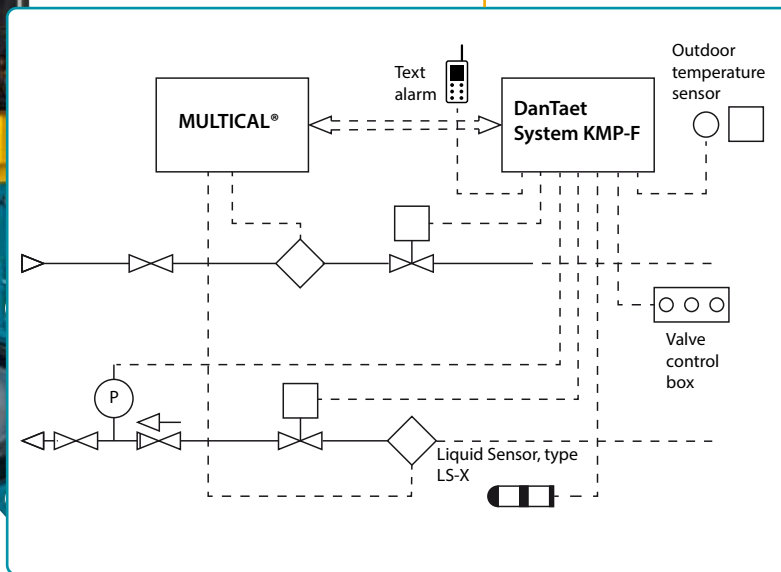

## Operating pressure monitor (Opt. P)

Installation is isolated at low operating pressure. Reduces loss of heating medium as well as restart difficulties.



## Liquid sensor attachment (Opt. V)

for two liquid sensors type LS-X for specific protection of sensitive areas with optional cut-off.

# Cooling

**Cooling – the removal of surplus heat** – is a process necessary to maintain production in our high-tech society, a process that ensures a reasonably comfortable workplace as well as operating conditions for machines and installations which are held within safe limits.

Many cooling systems employ liquid media for the energy transport - media that in case of leakage are capable of doing great damage to the sensitive technology and of causing major disruption of operations.

Together with Danish insurance companies and the Danish Institute of Technology, Kamstrup A/S and DanTaet a/s have developed [the KMP-K family of leak protection systems for cooling circuits with liquid media](#), which automatically intervene in case of leakage, minimizing the resulting damage and consequential disruption.

If desired, the leak protection systems may be configured to permit accurate measurement of energy transport in the protected cooling circuit, as Kamstrup can supply cooling meters that comply with the norms or energy calculation, even when the media contains antifreeze additives.

When designed-in, the leak protection system thus frequently permits the elimination of a planned secondary meter as Kamstrup supplies a wide range of plug-in modules with standard interfaces for data readout from the MULTICAL® meters.



# Cooling circuit leak protection

DanTaet system KMP-K is used for leak protection of cooling circuits from ½" to DN2000.

The system is available in versions for various media types and temperatures, with or without energy metering capability. All systems employ a Kamstrup MULTICAL® meter for flow measurement, while different meters and valves are used depending on system capacity, media composition and operating conditions.

System type	KMP-K6A/K8A	KMP-K6M/K8M
<b>Media</b>	Pure water	Mixed
<b>Energy metering</b>	Yes	Yes
<b>MULTICAL®</b>	603/803	603-M/803-M
<b>Temperature measuring range</b>	0..+180 °C	-40..+140 °C
<b>Flow sensor</b>	ULTRAFLOW® 44/54	Magnetic or mechanical
<b>Dimension</b>	½"-DN300	½"-DN2000

# Wide application range



The large capacity span makes the KMP-K family [suitable for application at all levels](#).

[The smallest systems](#) are used for protecting single machines, e.g.:

- extruders
- diecast mould machines
- CT- and MR-scanners
- fancoils



With a high sensitivity and fast response in a local cooling circuit, these systems are well-suited for protection of delicate machinery. Protection of diecast mould machines and extruders eliminates the risk of a flooded factory floor during unmanned operation.

[Medium size systems](#) are used for protection at room or building level, e.g.:

- server rooms
- dealer tables/floors
- A/C ventilation systems



With moderate sensitivity and response time, these systems are suited for protecting buildings and equipment from suffering major water damage in the event of leakage from the cooling circuit.

[The largest systems](#) serve as:

- main protection/monitoring in district or centrally cooled buildings
- protection/monitoring in cooling centrals, substations or plants



Large systems are frequently equipped with a separate valve control panel to assist uninterrupted cooling supply. The same panel permits manual execution of the OptiTight tightness check.

# Permanent Operation Monitoring (POM)

In Denmark, the district heating supplier is responsible for implementing a control system providing confidence that meters do not exceed the maximum allowed errors.

Whether you select traditional sampling or permanent operational monitoring, Kamstrup's accredited laboratory can perform this task for you.

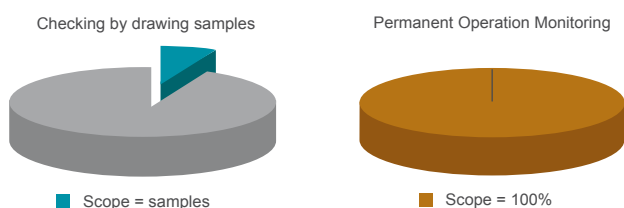

## The basic principles of POM

Permanent Operation Monitoring is based on the principle of one main meter and one test meter, also called redundant meters, mounted in the same installation. If the two meters in each test period present results within the limits, which are approved in the standard, both meters are considered to be all right.

In addition, Permanent Operation Monitoring includes checking of temperature sensors as a third temperature sensor is mounted close to either the inlet or the outlet sensor. In this way, the meters monitor the sensor stability.

Permanent Operation Monitoring comprises Kamstrup's heat meters MULTICAL® 66-C, MULTICAL® 601, MULTICAL® 602, MULTICAL® 603, MULTICAL® 801 and MULTICAL® 803 mounted with two identical flow meters for leak monitoring, three temperature sensors and remote reading.

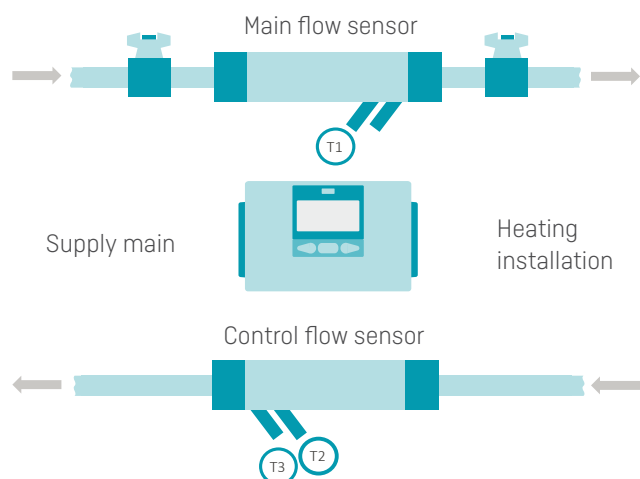

## Upgrade from leak monitoring to POM

If you already have MULTICAL® with leak monitoring and remote reading, you can benefit from upgrading your meter population to Permanent Operation Monitoring by installing a set of three sensors instead of the traditional sensor pair. If you do not have remote reading yet, you can easily upgrade your existing meters with communication modules.

Then, you only have to register the meters for Kamstrup's Permanent Operation Monitoring service. We then carry out the system test for you, and you receive both running status reports and a compiled annual report describing the "state of health" of the meter population.



## POM is approved by DANAK

Kamstrup's Permanent Operation Monitoring is tested by the independent institute DELTA. In addition, Danish Fundamental Metrology has assessed that Permanent Operation Monitoring provides confidence that the meters do not exceed the maximum allowed errors. Against this background, the Danish Accreditation and Metrology Fund - DANAK - has approved the application of Permanent Operation Monitoring as an alternative to the traditional sampling. Please contact Kamstrup to request the test reports. They are also available on Kamstrup's website.

## Who is authorised to carry out POM?

Like traditional sampling, all test measurements must be carried out by an accredited laboratory.

Assessment of the meter population results via remote reading and selection of meter exchanges must be performed by a DANAK authorised signee.

## Kamstrup and DanTaet – a solid partnership

Kamstrup and DanTaet have a technical cooperation ensuring simple and smooth extension of Kamstrup's leak monitoring with DanTaet's leak protection.

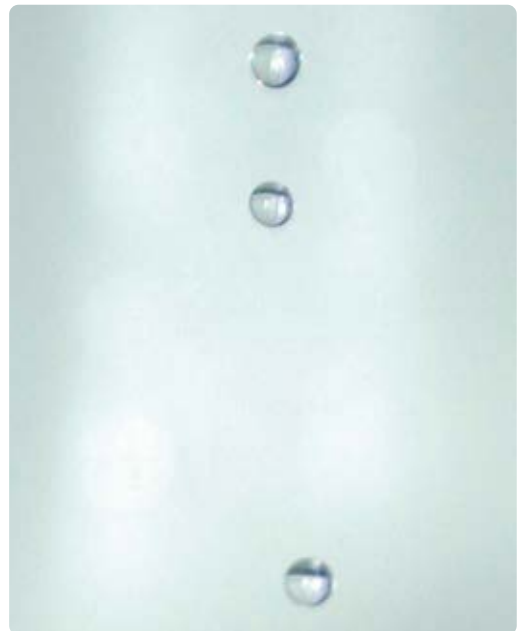

For meters, leak monitoring  
and remote reading, please contact:

**kamstrup**

Kamstrup A/S  
Industrivej 28, Stilling  
DK-8660 Skanderborg  
T: +45 89 93 10 00  
info@kamstrup.com  
www.kamstrup.com

**kamstrup**

Kamstrup Instrumentation Ltd.  
Unit 5B, Stour Valley Business Centre  
Brunton Lane, Sudbury  
UK-Suffolk CO10 7GB  
T: +44 17 87 31 90 81  
info@kamstrup.co.uk  
www.kamstrup.com

For leak protection and  
service, please contact:

**DANTAET**<sup>a/s</sup>

DanTaet A/S  
Højmevej 36-38  
DK-5250 Odense SV  
T: +45 63 17 45 00  
dantaet@dantaet.dk  
www.dantaet.dk

**DANTAET**<sup>a/s</sup>

DanTaet Ltd.  
3 Station Road  
Ashcott  
Somerset TA7 9QP  
T: 01458 210332  
dantaet@dantaet.co.uk  
www.dantaet.co.uk