

Whenever using Modbus RTU or BACnet® MS/TP the electrical communication runs via RS-485. RS 485 is a standard differential bus, which allows for high speed communication up to 400m. To work well, 3 demands must be fulfilled.

1) Cable

RS-485 uses 3 signals, A B and GND, typically a twisted pair with a screen used for GND. All 3 wires must be connected to all bus devices. Do not omit the screen.



Ask your local supplier for a “RS-485” cable

2) Wire topology



Line

Reccomended: Line topology

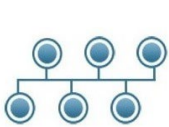

Bus



Tree



Ring



Star

Not reccomended:

Star, BUS, Tree or Ring topology

3) Line termination

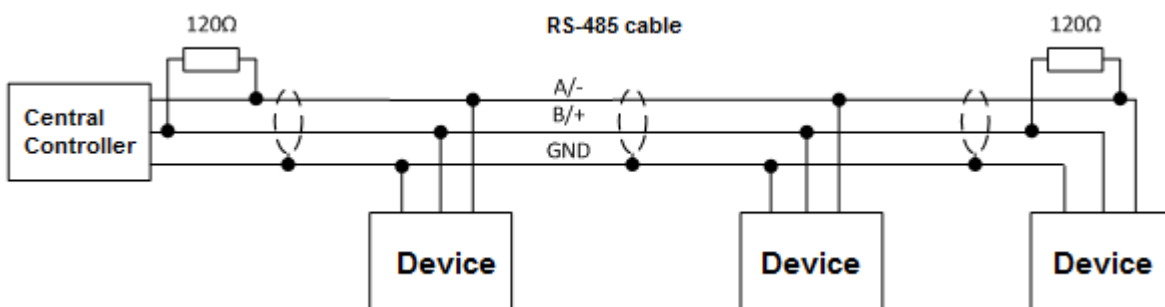

Line termination is extremely important, to keep the bus operating at its best performance.

One 120 Ohm resistor connected between the A and B wires – in both ends.

(Check if your equipment already have a built in line termination resistor)

For Modbus: All Modbus devices must be set-up with identical communication parameters: Baudrate, parity and stop bits.

For Modbus and BACnet: Always check for conflicting device-addresses.