

# SVM Analogue output board (FCAU)

## DATA SHEET

- 2 passive analogue outputs, 4-20mA
- Customized settings
- Power
- Flow
- Temperatures
- 2 analogue output boards may be installed in an F4



## Analogue output board (FCAU)

Calculator F4 can be equipped with an analogue board for increased functionality. The analogue board has two passive outputs 4-20mA. Up to two analogue output boards can be installed in an F4 for a total of four analogue outputs. Each output can be parameterized individually for power, flow, supply line, return line and differential temperatures. The analogue outputs are used e.g. for control and regulation systems, surveillance systems, computer displays or instruments.



# SVM Analogue output board (FCAU)

## DATA SHEET

### Analogue outputs

The analogue outputs are passive and thus must be supplied from an external power source. Supply the passive outputs with  $U_E = 24\text{ V} \pm 8\text{ V}$ , cf. Fig. 1 below. The analogue board is also equipped with varistor protection. Use an F4 adapter kit (article no. FT-4-adapt-kk) to configure the analogue board and choose two of the below parameters. If more than two parameters are required, a second analogue output board may be installed into the F4 calculator.

- Flow
- Power
- Forward Temperature
- Return Temperature
- Temperature Difference

**Note:** No negative values are displayed, and therefore the analogue output board cannot be used in the MF4 calculator.

**Note:** The analogue output board must only be mounted in a mains supplied F4.

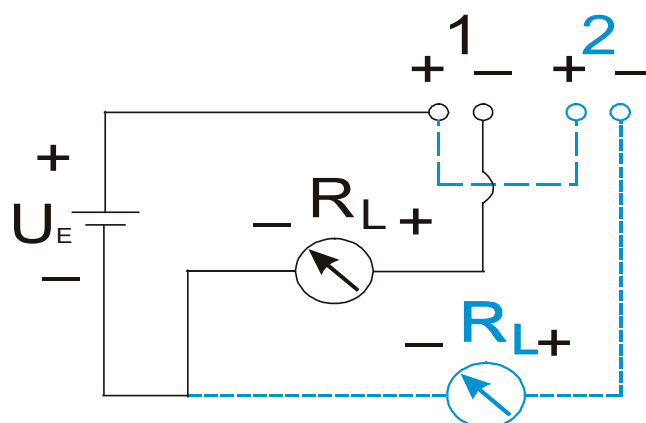

Fig.1. Connection diagram

### Data collection

The analogue output board collects data from the Calculator as follows:

#### Power and Flow

For these values the board uses a “watchdog timeout” which can be set in steps of 0.6 seconds. See Device specific help in the Plug & Play program for more information.

#### Temperature values

This value is updated each time the calculator performs a measurement, see also F4 manual.

**Note:** When installed the board will not operate until the first “watchdog timeout” has passed. The lowest value for the “watchdog timeout” is 35, corresponding to approximately 20 seconds.

# SVM Analogue output board (FCAU)

## DATA SHEET

### Card slots

---

The analogue output board should be installed in card slots B or E. If slots B and E are occupied with previously installed option boards, card slot A may also be used.

### Output data

---

#### Display

The following values are displayed in the LCD:

Sequence	Description
A1	Status channel 1
L1	Lower limit channel 1
U1	Upper limit channel 1
A1	Percentage XXX (0-100) channel 1
A2	Status channel 2
L2	Lower limit channel 2
U2	Upper limit channel 2
A2	Percentage XXX (0-100) channel 2

#### M-Bus

There is no data from the analogue output board available on the M-Bus.

#### Analog output

4–20mA, where the lower limit corresponds to 4mA and the upper limit corresponds to 20mA.

### Testing

---

The analogue output board has a built-in current level test. Set the dipswitches according to table 2 below.

**Important!** Never change the dipswitches when the option board is powered.

### Configuration

---

The analogue board must be configured prior to installation in the F4 calculator. Use the F4 adapter kit (Article code FT-4-adapt-kk) to configure and parametrize the board. The analogue output board may also be delivered pre-configured, cf. the “parameter file”.

# SVM Analogue output board (FCAU)

## DATA SHEET

### Connection

Card slot	Channel	Terminals	
		+	-
Slot A	1	A1	A2
	2	A3	A4
Slot B	1	B3	B4
	2	B1	B2
Slot E	1	E3	E4
	2	E1	E2

Table 1, Terminal connection depending on used card slot

### Dipswitches

To ensure that the F4 Calculator will communicate properly with the option board the dipswitches must be correctly set, see table 2 below.

Card slot (Current level)	BY 1	BY 2	BY 3	Mode
A	On			Normal operation
B		On		Normal operation
E	On		On	Normal operation
0 % ( 4mA)				Test
25 % ( 8mA)	On	On		Test
50 % (12mA)			On	Test
75 % (16mA)		On	On	Test
100% (20mA)	On	On	On	Test

Table 2, Dipswitch settings depending on used card slot

**Important!** Never change the settings of the dipswitches when the option board is powered.

# SVM Analogue output board (FCAU)

## DATA SHEET

### Installation

**It is very important that the power supply is disconnected when installing an option board, otherwise the calculator and/or option board may be damaged.**

The following procedure is recommended when installing an option board:

1. Short circuit the connection Save data to force the Calculator to save data in E2PROM.
2. Disconnect the flow sensor by removing one of the flow sensor cables from the calculator terminals.
3. Remove the power supply by disconnecting the 4-wire connectors K2 and K3.
4. Check that the dipswitches are correctly set for the selected card slot, and mount the option board into the slot. The component side shall be turned towards the terminals, and align the chambered end of the board with the right side of the calculator box. Ensure that all pins are correctly connected to the option board contact.
5. Turn the power back on by reconnecting the 4-wire connectors K3 (back-up battery) and K2 (RawV).  
**Note:** Mains power must be connected to calculator.
6. When additional boards are to be installed, repeat the steps 3-6 (above) for each board.
7. Connect the flow sensor.

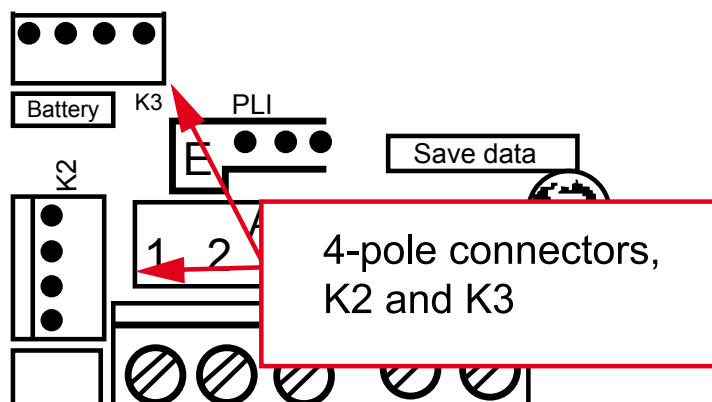

Fig.2. F4 connection terminals

# SVM Analogue output board (FCAU)

## DATA SHEET

### Ordering

Product designation: FCAU  
Delivery options: ABC  
Parameter file: XXXXXX

FCAU	A	B	C
2 passive analogue outputs	4		
Board delivered separately		1	
Board mounted inside F4 calculator		4	
Card slot A			A
Card slot B			B
Card slot E			E

Table 3, Ordering key

#### Parameter file

This file contains the parameters for a specific configuration. To create a customized parameter file, cf. the table on the next page, or contact Kamstrup SVM.

#### StandA

The parameter file "StandA indicates that the board is unconfigured. Note! The board must be configured prior to installation.

**Example 1:** FCAU-41B-Standa  
Analogue output board, delivered separate, for installation in slot B, unconfigured.  
**Note!** This board must be configured before installation.

**Example 2:** FCAU-41B-E01F15  
Analogue output board, delivered separate, for installation in slot B, configured.  
Channel 1: Power, 4 mA = 0 kW, 20 mA = 100 kW.  
Channel 2: Flow, 4 mA = 0 l/h, 20 mA = 1500 l/h

### Ordering key

Table 3 can be used to get correct ordering key. Fill out the blank fields.

FCAU-	A	B	C	-	Parameter file
	4			-	

Table 4, Ordering key

### Extra power supply

Calculator F4 with analogue output boards installed may in some cases need extra power from the mains supply. The part number for the mains supply board with a transformer for extra power is: 5100-3076-01.

# SVM Analogue output board (FCAU)

## DATA SHEET

### Parameter files

Pos A	Ch 1	B - C range	Step	Pos B - C	Pos D	Ch 2	E - F range	Step	Pos E - F
E	Power	100 - 9900 kW	100 kW	01 - 99	E	Power	100 - 9900 kW	100 kW	01 - 99
E	Power	10 - 19 MW	1 MW	A0 - A9	E	Power	10 - 19 MW	1 MW	A0 - A9
E	Power	20 - 65 MW	5 MW	B0 - B9	E	Power	20 - 65 MW	5 MW	B0 - B9
F	Flow	100 - 9900 l/h	100 l/h	01 - 99	F	Flow	100 - 9900 l/h	100 l/h	01 - 99
F	Flow	10 - 19 m3/h	1 m3/h	A0 - A9	F	Flow	10 - 19 m3/h	1 m3/h	A0 - A9
F	Flow	20 - 65 m3/h	5 m3/h	B0 - B9	F	Flow	20 - 65 m3/h	5 m3/h	B0 - B9
F	Flow	70-160 m3/h	10 m3/h	C0 - C9	F	Flow	70-160 m3/h	10 m3/h	C0 - C9
F	Flow	180 - 360 m3/h	20 m3/h	D0 - D9	F	Flow	180 - 360 m3/h	20 m3/h	D0 - D9
F	Flow	400 - 760 m3/h	40 m3/h	E0 - E9	F	Flow	400 - 760 m3/h	40 m3/h	E0 - E9
H	High T	1 - 99 gr C	1 gr C	01 - 99	H	High T	1 - 99 gr C	1 gr C	01 - 99
H	High T	100 - 190 gr C	10 gr C	A0 - A9	H	High T	100 - 190 gr C	10 gr C	A0 - A9
L	Low T	1 - 99 gr C	1 gr C	01 - 99	L	Low T	1 - 99 gr C	1 gr C	01 - 99
L	Low T	100 - 190 gr C	10 gr C	A0 - A9	L	Low T	100 - 190 gr C	10 gr C	A0 - A9
D	Delta T	1 - 99 K	1 K	01 - 99	D	Delta T	1 - 99 K	1 K	01 - 99
D	Delta T	100 - 190 K	10 K	A0 - A9	D	Delta T	100 - 190 K	10 K	A0 - A9

**Note!** In the Plug&Play software, values are always entered with the following units:

Power kW  
Flow m<sup>3</sup>/h

#### Default settings

10% filter, 3 values.

The above means that changes greater than 10% are accepted only after three consecutive stable measurement periods.

Watchdog timeout = 35