

Installation and User Guide

MULTICAL® 602 & ULTRAFLOW® 14
Cooling meter



Operation conditions

Operation conditions/measuring ranges

Calculator	θ : 2 °C...180 °C	$\Delta\theta$: 3K...170K
Temperature sensor pair	θ : 2 °C...50 °C	$\Delta\theta$: 3K...30K
Flow sensor	θ : 2 °C...50 °C	

Mechanical environment

M1 (fixed installation with minimum vibration).

Electromagnetic environment

E1 (Domestic and light industrial). Signal cables from the meter must be separated by at least 25 cm distance to other installations.

Climatic environment

The installation of MULTICAL® shall be made in non-condensing environments and in closed location (indoor). The ambient temperature must be within 5...55°C.

Maintenance and repair

The energy supplier is allowed to change communication module, battery and temperature sensor pair. The flow sensor must not be separated from the base unit that contains the flow sensor electronics. All repairs require a following calibration on an accredited laboratory.

MULTICAL® 602, type 602-C is suitable for temperature sensors type Pt500.

Battery for replacement

Kamstrup type 1606-064.

Installation and User Guide

MULTICAL® 602 & ULTRAFLOW® 14 Cooling meter

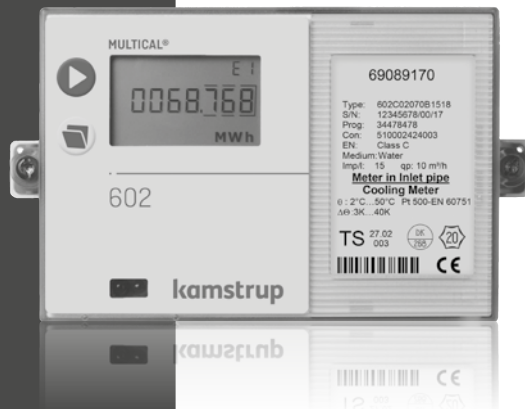

Contents

1	General information	4	5	Installation as compact meter	9
2	Mounting of temperature sensors	5	5.1	Power supply	10
	2.1 Pocket sensor (PL)	5	5.2	Mains supply	11
	2.2 Short direct sensor (DS)	5	5.3	Operational check	11
3	Mounting of flow sensor	6	5.4	Electrical connection	12
	3.1 Mounting of ULTRAFLOW®	7	6	Information codes "INFO"	13
4	Mounting of the calculator/Pulse Transmitter (66-99-617)	7	7	Plug-in modules	14
	4.1 In cooling applications	7	7.1	Base modules	14
	4.2 In applications with medium temperature higher than the ambient temperature	9	7.2	Top modules	17
			7.3	Module overview	19
			8	Installation of flow sensor as separate meter	20
			8.1	Electric connection	20
			9	Setup via front keys	21

1 General information

⚠ Read this guide before installing the energy meter. If the meter is installed incorrectly, Kamstrup's guarantee obligations will no longer apply.

Please note that the following installation conditions must be obeyed:

- Pressure stage ULTRAFLOW®: PN16/PN25, see marking. Marking of flow sensor does not cover included accessories.
- Pressure stage Kamstrup sensor set type DS: PN16/PN25
- Pressure stage Kamstrup stainless steel pockets: PN25

2 Mounting of temperature sensors

The temperature sensors used for measuring inlet and outlet temperatures respectively, constitute a matched sensor pair, which must never be separated. According to EN 1434/OIML R75, the cable length must not be changed. Should replacement be necessary, both sensors must be replaced.

The sensor marked with a red sign is to be installed in the inlet pipe. The other sensor, marked with a blue sign, is to be installed in the outlet pipe. For mounting in the calculator, see the paragraph "Electrical connection".

Note: The sensor cables must neither be exposed to jerking nor pulling. Please be aware of this when binding the cables, and be careful not to pull the binders unnecessarily tight as this may damage the cables. Please also note that temperature sensors must be mounted from below in cooling and heat/cooling installations.

2.1 Pocket sensor (PL)

The sensor pockets can be mounted in e.g. a welding sleeve or in a 45° lateral Y-piece. The tip of the sensor pocket must be placed in the middle of the flow. Push the temperature sensors as deep as possible into the pockets. If a short response time is required, "non-hardening" thermally conductive paste can be used. Push the plastic sleeve on the sensor cable into the sensor pocket and secure the cable by means of the enclosed M4 sealing screw. Fasten the screw with your fingers only. Seal the pockets using seal and locking wire.

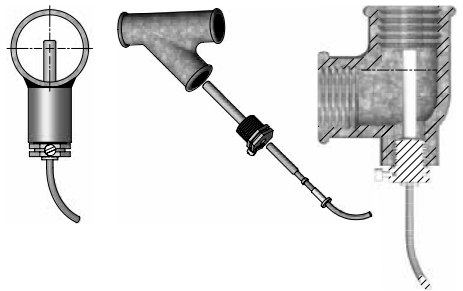

2.2 Short direct sensor (DS)

The short, direct sensors up to DN25 can be mounted in special ball valves with built-in M 10 socket for the short direct sensor. They can also be mounted in installations with standard tee-pieces. Kamstrup A/S can supply R½ and R¾ brass nipples that fit the short direct sensors. The short direct sensor can also be mounted directly in selected flow sensors from Kamstrup A/S. Fasten the sensors' brass unions lightly [approx. 4 Nm] using a 12 mm face wrench, and seal the sensors with seal and locking wire.

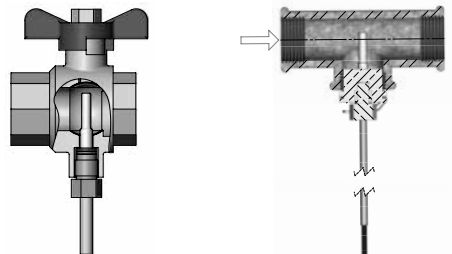

3 Mounting of flow sensor

Before mounting the flow sensor, flush the system thoroughly and remove protection plugs/plastic membranes from the flow sensor. Correct flow sensor position (inlet or outlet pipe) appears from the front label placed on the MULTICAL® 602. The flow direction is indicated by an arrow on the side of the flow sensor. Glands and gaskets must be mounted as shown on the above drawing.

Straight inlet: ULTRAFLOW® requires neither straight inlet nor outlet to meet the Measuring Instruments Directive (MID) 2014/32/EU, OIML R75:2002 and EN 1434:2015. Only in case of heavy flow disturbances before the meter will a straight inlet section be necessary. We recommend to follow the guidelines in CEN CR 13582.

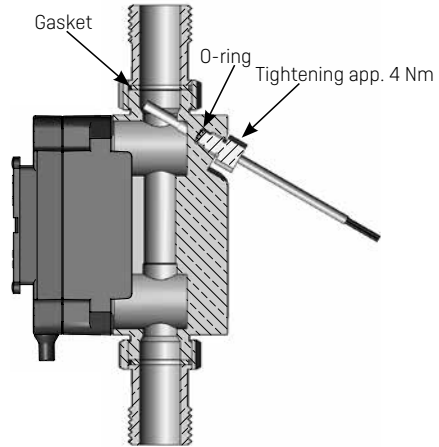

- A** Recommended position.
- B** Recommended position.
- C** Unacceptable position due to risk of air build-up.
- D** Acceptable position in closed systems.
- E** Ought not to be placed immediately after a valve, with the exception of block valves (ball valve type) which must be fully open when not used for blocking.
- F** Ought not to be placed immediately before or after a pump.
- G** Ought not to be placed immediately after a double bend in two planes.

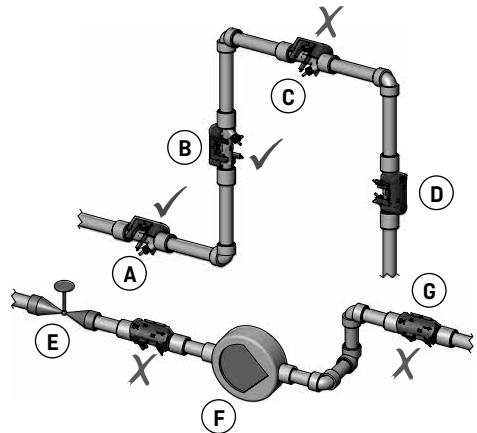

To prevent cavitation, the operating pressure at the ULTRAFLOW® must be min. 1.5 bar at q_p and min. 2.5 bar at q_s .

ULTRAFLOW® must not be exposed to pressures below ambient pressure (vacuum).

3.1 Mounting of ULTRAFLOW®

ULTRAFLOW® can be mounted vertically, horizontally or at an angle. The electronics/plastic box must be placed on the side [at horizontal mounting].

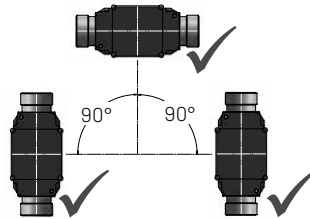

ULTRAFLOW® may be turned up to +45° around to the pipe axis.

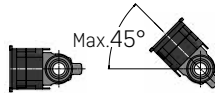

ULTRAFLOW® must not be mounted with the plastic case pointing upwards or downwards.



4 Mounting of the calculator/Pulse Transmitter (66-99-617)

4.1 In cooling applications

The MULTICAL® 602 calculator can be mounted in two different ways:

4.1.1 Separately/wall mounting

In connection with mounting in condensing environments as well as in order to prolong the battery lifetime, we recommend the use of a wall fitting.

The wall fitting makes it possible to mount MULTICAL® 602 direct on an even wall. Use the fitting as a template to mark and drill two 6 mm holes in the wall.

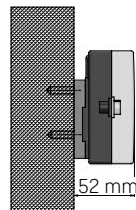

Installation of calculator/Pulse Transmitter

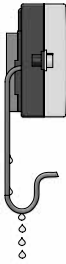

Front, vertical



Front, at an angle
between horizontal
and vertical

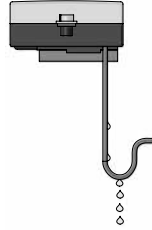

Front, horizontal.
By means of angle
fitting type 30-26-252
[ordered separately].

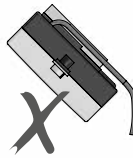
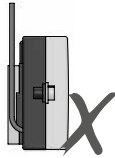

Note: Cables **must** be installed from below.

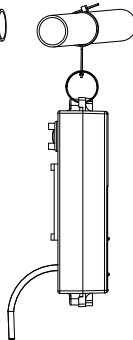
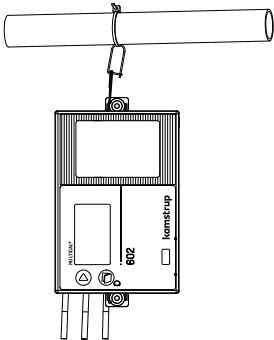

Installation example with suspension.

Note: The suspension **must** not be used on condensing pipes.
Suspension kit item no. 5915-144. Not included.

4.2 In applications with medium temperature higher than the ambient temperature

In applications, with medium temperature that is higher than the ambient temperature, calculator/Pulse Transmitter can also be mounted on the flow sensor. *See examples below.*

Threaded meter with MULTICAL®/Pulse Transmitter mounted on ULTRAFLOW®

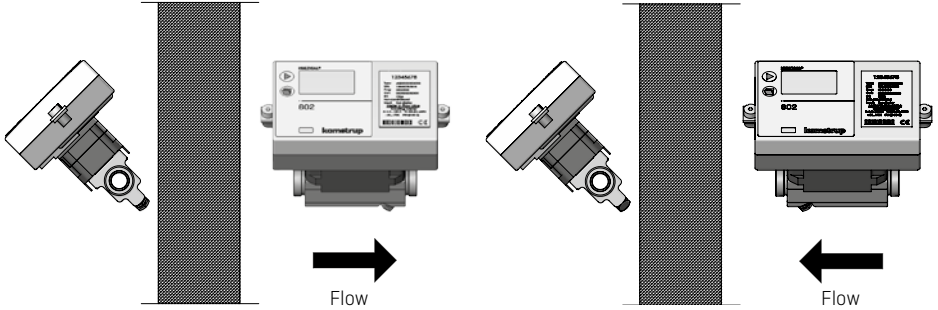

Flange meter with MULTICAL®/Pulse Transmitter mounted on ULTRAFLOW®

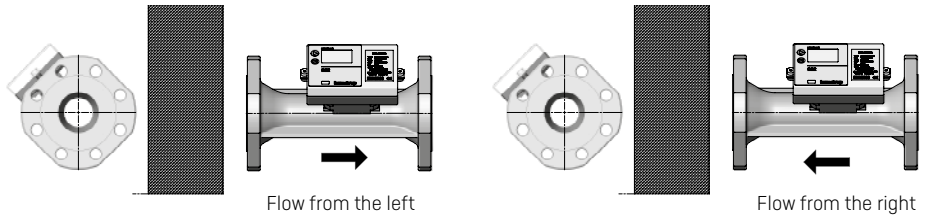

5 Installation as compact meter

MULTICAL® mounted together with flow sensor electronic.

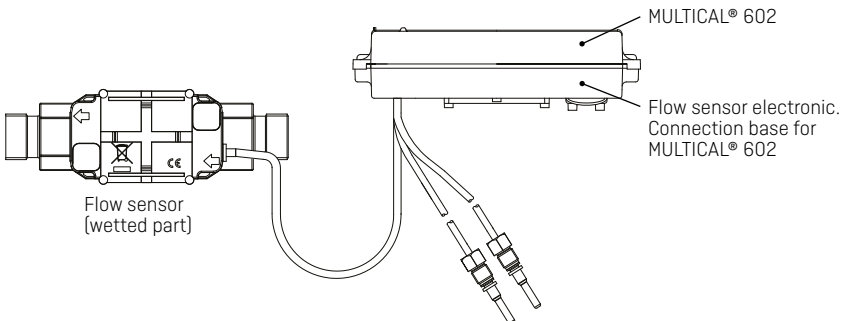

Note: ⚠ Flow sensor cable, cable between flow sensor (wetted part) and flow sensor electronic, must not be disconnected/changed or cut.

5.1 Power supply

MULTICAL® 602 can be power supplied by means of a built-in lithium battery, an internal 24 VAC mains module or an internal 230 VAC mains module.

The two wires from the battery or mains module are mounted in terminals 60 and 61 of the calculator.

 The polarity has to be correct; connect the red wire to terminal no. 60 (+) and the black wire to terminal no. 61 (-).

5.1.1 Battery supply

MULTICAL® 602 is connected to a lithium battery, D-cell. The battery is marked with installation year, e.g. 2016, as well as production date.

Optimal battery life is obtained by keeping the battery temperature below 30°C, e.g. by wall mounting.

The voltage of a lithium battery is almost constant throughout the whole lifetime of the battery (approx. 3.65 V). Therefore, it is not possible to determine the remaining capacity by measuring the voltage.

The battery cannot and must not be charged and must not be short-circuited. Used batteries must be handed in for approved destruction, e.g. at Kamstrup's.

5.2 Mains supply

MULTICAL® 602 is available with supply modules for either 24 VAC or 230 VAC.

The modules are protection class II and are connected via two-wire cable (without earth) through the big cable bush, the second one from the right, at the bottom of the connection base. Use connecting cable with an outer diameter of 5-10 mm and ensure correct cable stripping as well as correct mounting of cable relief.

If connecting to 230 VAC, it is important to make sure that the whole installation complies with current regulations. The supply cable must not be protected by a fuse larger than the one permitted for the given cable size, see examples below.

Supply cable	Max. Fuse
2 x 0.75 mm ² [accessory from Kamstrup A/S]	6 A
2 x 1.0 mm ²	10 A

In connection with other types of installations or requirements for larger fuses than the ones listed above, it is necessary to consult a certified electrician for an individual evaluation of how the type of installation in question should be carried out.

In addition please note that work on the fixed installations, including any intervention in the fuse box, must be carried out by an authorized electrician.

5.3 Operational check

Carry out an operational check when the energy meter has been fully mounted. Open thermo-regulators and valves in order to establish a water flow through the installation. Activate the upper push button on the MULTICAL® 602 and check that the display values for temperature and water flow are reliable.

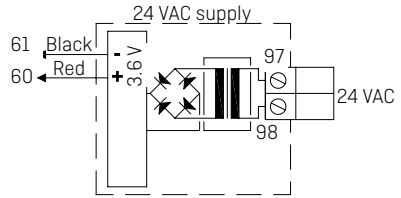

24 VAC

E.g. transformer 230/24 V, type 66-99-403, can be used.

Note: MULTICAL® 403 cannot be powered by 24 VDC.

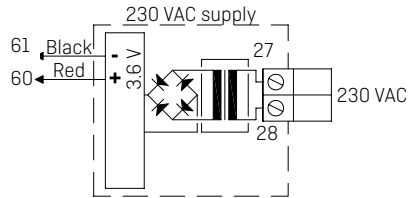

230 VAC

This module is used when the meter is supplied directly by the mains.

Note: External supply must only be connected to the supply module.

5.4 Electrical connection

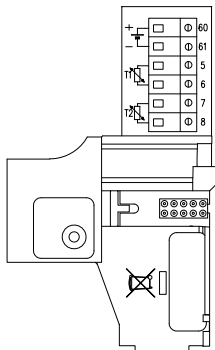

The polarity of the temperature sensors T1 and T2 is unimportant.

	Terminal No.	Standard measurement of heat and cooling
T1	5-6	Sensor in inlet pipe (red)
T2	7-8	Sensor in outlet pipe (blue)

6 Information codes "INFO"

MULTICAL® 602 constantly monitors a series of important functions. If a serious error occurs in the measuring system or in the installation, an "INFO" appears in the display and an info code can be read by activating the upper front plate button until the measuring unit shows an "INFO" in the display. The info code is only visible while the error exists.

Info code	Description	Response time
0	No irregularities	-
1	Supply voltage has been cut off	-
8	Temperature sensor T1 outside measuring range	1...10 min.
4	Temperature sensor T2 outside measuring range	1...10 min.
ULTRAFLOW® 14 info (if activated CCC=4XX)		
16	Flow sensor V1, Datacomm error, signal too low or wrong flow direction	After reset and 1 day [00:00]
2048	Flow sensor V1, Wrong meter factor	After reset and 1 day [00:00]
4096	Flow sensor V1, Signal too low [Air]	After reset and 1 day [00:00]
16384	Flow sensor V1, Wrong flow direction	After reset and 1 day [00:00]

If several info codes appear at the same time the sum of the info codes is shown. E.g. if both temperature sensors are outside measuring range, info code 12 will appear.

7 Plug-in modules

MULTICAL® 602 can be extended by a wide range of extra functions by means of plug-in modules. The individual modules are briefly described below.

7.1 Base modules

7.1.1 Data + pulse inputs, type 67-00-10

The data terminals are used for connection of e.g. a PC. The signal is passive and galvanically separated by means of optocouplers. Conversion into RS232 level requires connection of data cable 66-99-106 (D-Sub 9F) or 66-99-098 (USB) using the following connections:

62	Brown	[DAT]
63	White	[REQ]
64	Green	[GND]

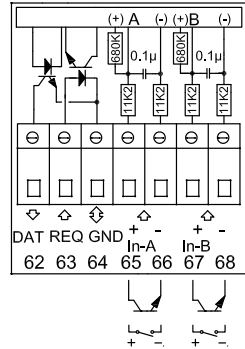

The pulse inputs can be used for connection of electricity and water meters.

Please pay attention to maximum pulse frequency as well as correct pulse coding (l/imp. and Wh/imp.), which is selected by means of the FF and GG configuration.

65 - 66	Input A
67 - 68	Input B

7.1.2 M-Bus + pulse inputs, type 67-00-20/27/28/29

M-Bus can be mounted in star, ring or bus topology. Up to 250 meters can be connected depending on the M-Bus Master's power supply and the total cable resistance.

Cable resistance < 29 Ohm

Cable capacity < 180 nF

The M-Bus network is connected on terminals 24 and 25. The polarity is unimportant.

M-Bus comes with pulse inputs.

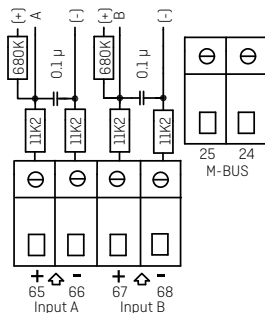

7.1.3 Radio + pulse inputs, 67-00-21/25/26

The radio module is used for wireless communication via licence-free radio frequency and can be supplied with internal antenna or with connection for external antenna.

For further information on radio we refer to

Technical description for radio [5512-013].

The pulse inputs of this module are identical with the previously described pulse inputs.

Note: Type 67-00-21 includes radio and router functions.

The RadioRouter module (67-00-21) must be used with mains supply.

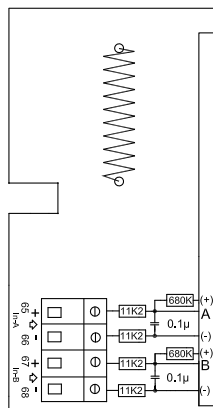

7.1.4 Prog. data logger + RTC + 4...20 mA inputs + pulse inputs, type 67-00-22

The module has connection possibility for two pressure transmitters on terminals 57, 58 and 59 and can be adjusted for current reading or pressure range 6, 10 or 16 bar.

The module is prepared for remote reading, data from meter/module being transferred to the system software via the external GSM/GPRS modem connected on terminals 62, 63 and 64.

Furthermore, the module has two extra pulse inputs, VA and VB.

The module must be powered by 24 VAC.

7.1.5 Analog outputs, type 67-00-23

See installation instructions 5512-369 (DK-GB-DE).

7.1.6 LonWorks + pulse inputs, type 67-00-24

See installation instructions 5512-396 (DK) or 5512-403 (GB).

7.1.7 Wireless M-Bus, type 67-00-30

The radio module has been designed to form part of the hand-held Wireless M-Bus Reader systems of Kamstrup A/S at license-free radio frequency (868 MHz).

The module fulfils the C-mode specifications of prEN13757-4 and can thus form part of other systems using Wireless M-Bus C-mode communication.

The radio module comes with internal antenna and external antenna connection as well as two pulse inputs, which are identical with the previously described pulse inputs.

The Wireless M-Bus radio transmitter is switched off on dispatch from the factory. It turns on automatically when one litre of water has run through the meter. The radio transmitter can also be switched on by means of a forced dial-up to the meter (keep both front keys pressed for approx. 5 s. until CALL is displayed).

7.1.8 ZigBee® + pulse inputs, type 67-00-60

The ZigBee® module is used for wireless communication and can form part of a remote reading system, in which several units can communicate with each other.

The pulse inputs of this module are identical with the previously described pulse inputs.

The ZigBee® module requires mains supply.

7.1.9 Metasys N2 + pulse inputs, type 67-00-62

The N2 module is used for data communication between meter and N2 Master in a Johnson Controls System.

The RS485 port is galvanically separated from the meter.

The pulse inputs of this module are identical with the previously described pulse inputs.

The N2 module requires mains supply.

7.1.10 SIOX module (Auto detect Baud rate), type 602-00-64

SIOX is used for data reading of small and medium-sized groups of meters via cable, the data readings being presented by the main system, e.g. MCom, Fix or Telefrang. Further information on these systems can be ordered from the supplier in question. Furthermore, a configuration tool is available from Telefrang.

The two-wire serial SIOX bus connection is optoisolated from the meter and is connected without regard to polarity (i.e. the polarity is unimportant). The module is powered by the SIOX bus.

Communication speed between 300 and 19,200 baud. The module automatically uses the highest possible communication speed. The module converts data from KMP protocol to SIOX protocol.

7.1.11 GSM/GPRS module (GSM6H), type 602-00-80

The GSM/GPRS module functions as transparent communication path between reading software and MULTICAL® 602 and is used for data reading. The module includes an external dual-band GSM antenna which must be used. The module itself includes a number of light emitting diodes indicating the signal level, which are very useful during installation. The GSM/GPRS module must be used together with high-power mains supply (230 VAC: 602-00-00-2 and 24 VAC: 602-00-00-3).

7.1.12 Ethernet/IP module (IP201), type 602-00-82

The IP module functions as transparent communication between reading software and MULTICAL® 602 and is used for data reading. The Module supports both dynamic and static addressing. This is specified in the order or selected during subsequent configuration. The module has no built-in security and must, therefore, always be used in connection with a firewall or NAT. The Ethernet/IP module must be used together with high-power mains supply (230 VAC: 602-00-00-3 and 24 VAC: 602-00-00-4).

7.1.13 High-Power RadioRouter + pulse inputs, type 602-00-84

The High-Power RadioRouter module has built-in router functionality and is thus optimized to form part of a Kamstrup radio network, the read data being automatically transferred to system software via the network unit RF Concentrator. Furthermore, the module can be read by Kamstrup's hand-held reading systems, e.g. USB Meter Reader and MULTITERM Pro.

The RadioRouter module is available for operation in both licence-free and licence demanding frequencies permitting a transmitting strength of up to 500 mW. The module is by default fitted with internal antenna, connection for external antenna, and two extra pulse inputs. The High Power RadioRouter module (602-00-84) must be used together with the High Power mains supply (230 VAC: 602-00-00-3 and 24 VAC: 602-00-00-4).

7.2 Top modules

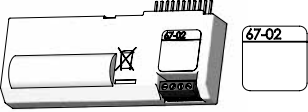
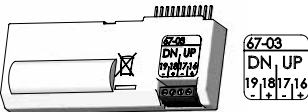
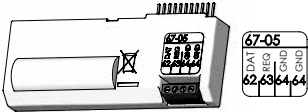
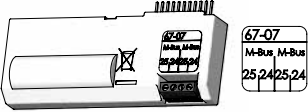
<p>Type 67-02: ΔEnergy calculation and hourly data logger</p> <p>This top module calculates the difference between inlet and outlet energy, whereby an expression of the tapped energy in open systems is obtained.</p> <p>Differential energy $dE=E4-E5$.</p> <p>The module also includes an hourly data logger.</p> <p>The connection terminals of this module are not used.</p>	
<p>Type 67-03: PQT-limiter + hourly data logger</p> <p>The module has two pulse outputs which can be used for UP/DOWN control of a low-speed three-point motor-operated valve via an external solid-state relay, type S75-90-006 and a 230/24 V transformer, type 66-99-403. The required power and flow limits are entered into MULTICAL® 602 by means of the PC-program METERTOOL.</p> <p>Also see instructions: 5512-498.</p> <p>The module includes an hourly data logger too.</p>	
<p>Type 67-05: Data output + hourly data logger</p> <p>The module has a galvanically separated data port which functions together with the KMP protocol. The data output can be used for e.g. connection of external communication units or other hardwired data communication which it is not expedient to carry out via optical communication on the meter's front.</p> <p>62: DATA (brown)-63:REQ (white)-64: GND (green). Use data cable type 66-99-106 with 9-pole D-sub or type 66-99-098 with USB connector.</p> <p>The module includes an hourly data logger.</p> <p>Only current and accumulated data can be read.</p> <p>Hourly/daily/monthly/yearly data loggers cannot be read through the data port of top module 67-05.</p>	
<p>Type 67-07: M-Bus</p> <p>M-Bus can be connected in star, ring and bus topology. Depending on M-Bus Master and cable length/cross section, up to 250 meters with primary addressing can be connected, and even more using secondary addressing.</p> <p>Cable resistance in network: < 29 Ohm</p> <p>Cable capacity of network: < 180 nF</p> <p>The connection polarity of terminals 24-25 is un-important.</p> <p>Usually the primary address is identical with the last digits of the customer number (000-250). However, it can be changed by means of the PC program, METERTOOL.</p>	

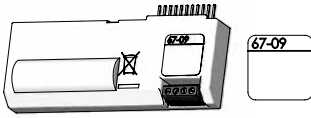
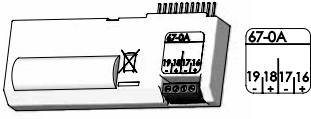
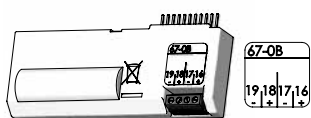
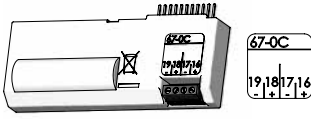
<p>Type 67-09: ΔVolume calculation and hourly data logger</p> <p>This top module calculates the difference between inlet and outlet volume, whereby an expression of the tapped volume in open systems is obtained.</p> <p>Differential volume $dV=V1-V2$.</p> <p>The module also includes an hourly data logger.</p> <p>The connection terminals are not used in this module.</p>	
<p>Type 67-0A: 2 pulse outputs for CE and CV + hourly data logger + scheduler</p> <p>The top module has the same functions as top module 602-0C. Furthermore, the module can simulate a cold water temperature according to a programmed scheduler, in which T2, T3 or T4 can be programmed with up to 12 individual dates/temperatures per year.</p>	
<p>Type 67-0B: 2 pulse outputs for CE and CV + prog. data logger</p> <p>The RTC and pulse output functions of this top module are identical with the functions described for top module 602-0C (see below).</p> <p>The top module is prepared for use in a Kamstrup radio network together with High Power RadioRouter base module 6020084, read data being transferred to the system software via the network unit RF Concentrator.</p>	
<p>Type 602-0C: 2 pulse outputs for CE and CV</p> <p>This top module has two configurable pulse outputs, which are suitable for volume and energy pulses for heat meters, cooling meters and combined heat/cooling meters.</p> <p>The pulse resolution follows the display (determined by the CCC code). E.g. CCC=119 ($q_p 1,5$): 1 pulse/kWh and 1 pulse/0.01 m³.</p> <p>The pulse outputs are optoisolated and withstand 30 VDC and 10 mA.</p> <p>Normally energy (CE) is connected to 16-17 and volume (CV) to 18-19, but other combinations can be selected by means of the PC program METERTOOL HCW, which is also used for selecting the pulse duration at either 32 or 100 ms.</p>	

7.3 Module overview

MULTICAL® 602 Communication modules #2

Type No.	Description	Module No.
67-02	RTC + Δ energy calculation + hourly data logger	5550-860
67-03	RTC + P, Q or Δt limiter + hourly data logger	5550-860
67-05	RTC + data output + hourly data logger	5550-904
67-07	RTC + M-Bus	5550-838
67-09	RTC + Δ volume + hourly data logger	5550-860
67-0A	RTC + 2 pulse outputs for CE and CV + hourly data logger + scheduler	5550-860
67-0B	RTC + 2 pulse outputs for CE and CV + prog. data logger	5550-942
602-0C	2 pulse outputs for CE and CV	5550-1163

MULTICAL® 602 Communication modules #1

Type No.	Description	Module No.
67-00-10	Data + pulse inputs	5550-369
67-00-20	M-Bus + pulse inputs	5550-831
67-00-21	RadioRouter + pulse inputs	5550-805
67-00-22	Prog. data logger + RTC + 4...20 mA inputs + pulse inputs	5550-925
67-00-23	0/4...20 mA outputs	5550-1005
67-00-24	LonWorks, FTT-10A + pulse inputs	5550-1128
67-00-25	Radio + pulse inputs (internal antenna)	5550-608
67-00-26	Radio + pulse inputs (for external antenna)	5550-640
67-00-27	M-Bus module with alternative registers + pulse inputs	5550-997
67-00-28	M-Bus module with medium data package + pulse inputs	5550-1104
67-00-29	M-Bus module with MULTICAL® III data package + pulse inputs	5550-1125
602-00-30	Wireless M-Bus, C1, standard registers, encrypted, 868 MHz, internal and external antennas, pulse inputs	5550-1205
602-00-35	Wireless M-Bus, C1, alternative registers, encrypted, 868 MHz, internal and external antennas, pulse inputs	5550-1206
67-00-60	ZigBee® 2.4 GHz internal antenna + pulse inputs	5550-992
67-00-62	Metasys N2 (RS-485) + pulse inputs	5550-1110
602-00-64	SIOX module (Auto detect baud rate)	5920-193
67-00-66	BACnet MS/TP (B-ASC) RS-485 + pulse inputs	5550-1240
602-00-80	GSM/GPRS module (GSM6H)	5550-1137
602-00-81	3G GSM/GPRS module (GSM8H)	5550-1209
602-00-82	Ethernet/IP module (IP201)	5550-844
602-00-84	High Power Radio Router + pulse inputs	5550-1116

8 Installation of flow sensor as separate meter

Pulse Transmitter mounted together with flow sensor electronic.

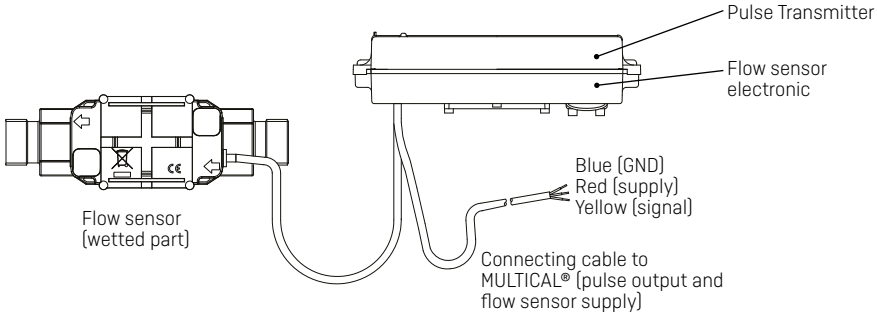

Note: ⚠ Flow sensor cable, cable between flow sensor (wetted part) and flow sensor electronic, must not be disconnected/changed or cut.

8.1 Electric connection

Connection MULTICAL® (separate calculator) and ULTRAFLW® 14 incl. Pulse Transmitter (66-99-617). ULTRAFLW® 14 incl. Pulse Transmitter is supplied from MULTICAL®.

Note: Do not mount power supply inside Pulse Transmitter (66-99-617).

ULTRAFLW® 14 incl. Pulse Transmitter, Cable.	→	MULTICAL® Bracket, (separate calculator)
Blue (GND)	→	11
Red (supply)	→	9
Yellow (signal)	→	10

Connection example

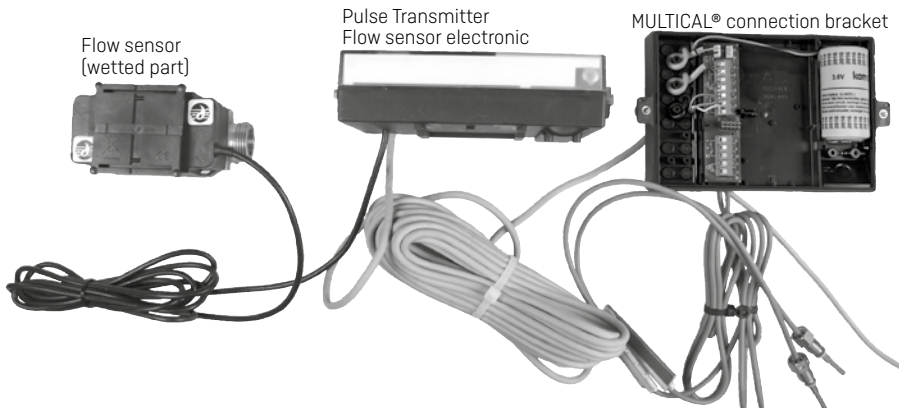

9 Setup via front keys

Date, time and primary M-Bus address can be adjusted by means of the keys on the calculator's front.

- 1 In the display you select the reading you want to change
- 2 Lift off the calculator top
- 3 Wait until the meter has shut down (up to 2.5 minutes). Do not press any keys
- 4 Keep the primary key activated  while mounting the calculator top, until there are no more lines in the display.
- 5 The setup menu is now active.

Having activated the set-up menu the reading you want to change is displayed with the rightmost digit flashing:



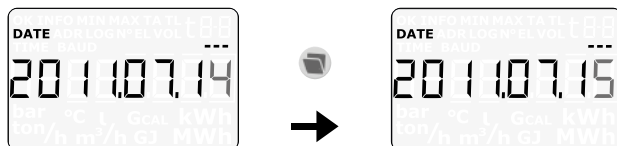

The value of the flashing digit can be changed by pressing the secondary key . The digit is increased by one each time the key is pressed, and passing 9 it starts from 0:



Pressing the main key  you go to the next digit from right to left:



The active digit flashes and this digit can now be changed by pressing the secondary key . You go to the first digit on the right by pressing the primary key .

When the value of the reading has been changed you quit by keeping the primary key  activated for approx. 10 seconds.

It should be checked that the value is credible for the reading in question. If so, the value is saved and a "OK" symbol is displayed. If not, the old value is maintained, no "OK" symbol appears, and the display reverts to legal reading.

User guide

Energy Measurement

MULTICAL® 602 functions in the following way:

The flow sensor registers the amount of district heating water circulating through the heating system in m³ (cubic metres).

The temperature sensors placed in inlet and outlet pipes, register the cooling, i.e. the difference between input and output temperatures.

MULTICAL® 602 calculates consumed energy based on volume of district heating water and cooling.

Readings

When the top front key  is activated, a new reading appears.

The lower front key  displays historical readings and average values.

Four minutes after the latest activation of the front key the meter automatically switches to consumed energy.

Displays

Consumed energy in kWh,
MWh or G.J.

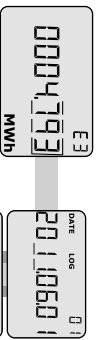

Latest target date.



Energy count on latest target date followed by energy count on last year's target date.
Followed by monthly counts.

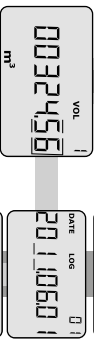

Latest target date.

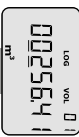

Volume count on latest target date followed by volume count on last year's target date.
Followed by monthly counts.

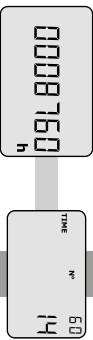

Number of hours with errors.

Current inlet pipe temperature.



Yearly average inlet temperature.

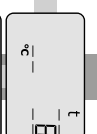

Current outlet pipe temperature
Current outlet pipe temperature



Yearly average outlet temperature.

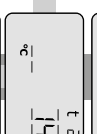

Current temperature difference.



Current water flow.
Press  to see the peak value of the current year and historic yearly and monthly values.

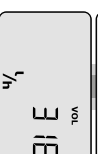

Current cooling power.
Press  to see the peak value of the current year and historic yearly and monthly values.
Followed by the accumulated water consumption on inputs A and B and tariff registers TA2 and TA.



Current information code.
(contact the utility if the figure differs from '0')



Reading of number of INFO code events.

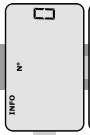

Data logger shows date ...



... and then the INFO codes of the latest 36 events.

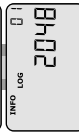

The first max. 8 digits of the customer number.

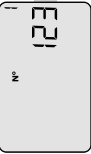

The last 8 digits of the customer number. This example displays customer number 12345678912.

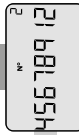

Current date.

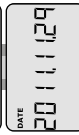

Current time.



Target date displayed as month and day. In this example June 1.

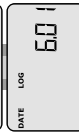

The calculator's serial number.



The calculator's program no. In this example: Flow sensor in outlet pipe, MWh and 100 imp/l.



Followed by the calculator's configuration no and software edition.



Display test.
 Followed by top and base module types.

DDD = 510

Also see interactive user's guides at www.kamstrup.com.

