

Kamstrup 382 DIN

kWh meter 5(85)A 382GH

Measurement in 4 quadrant

Active positive
Active negative
Reactive positive
Reactive negative

Measurement in up to 8 tariffs

Voltage quality measurement

Safe data logging of consumption

Safe data logging of events

Immune to magnetic influence

OBIS identification codes

Real time clock (RTC) with supercap
backup

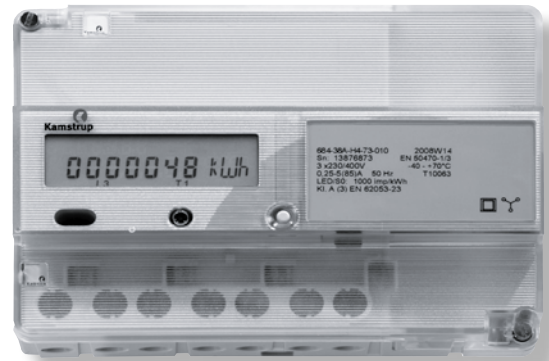

Type approved according to:

Active positive energy

EN 50470-1 (MID)

EN 50470-3 (MID)

Active negative energy and reactive
energy

IEC 62052-11

IEC 62053-21

IEC 62053-23

Application

Kamstrup 382 DIN is a direct connected electricity meter for registration of electric energy. The meter is full electronic without movable parts. Thus, shock and impact during transportation and mounting do not affect energy registration.

The shunt measuring principle gives good linearity and a considerable dynamic range. The shunt measuring principle is immune against magnetism and DC currents.

The easily readable display scrolls automatically between readings, or readings can be changed manually by the consumer activating a push button. The required display readings as well as their order are configurable.

In addition to being read from the display data can be collected via the optical output or from the module area by means of a suitable communication module. The unique module area permits external changing of tariffs, pulse input and output, and configuration as well as connection of AMR and AMM modules.

From the factory the meter can be configured to measure both imported and exported energy. As it is constructed with three independent and galvanically separated measuring systems, the meter makes accurate measurements whether it measures on 1, 2 or 3 systems. The energy registration is saved in the integral datalogger, which ensures good data history with its depth of 36 loggings.

The meter construction is made so that the measuring accuracy will not be influenced by magnetism.

The meter includes real time clock (RTC) with supercap backup for tariff control and time-stamping of data and events.

The tariff control can change between max. 8 tariffs. The internal clock (RTC), on the basis of pre-programmed timetables, can change the tariffs. Summer time/standard time and holidays can also effect the tariff shifts.

The meter is configurable and can be supplied from the factory with required functions. A minimum of handling during installation is thus secured.

The DIN-rail construction makes the meter suitable for measurement in industrial environments as it fits existing DIN-rail panels.

Furthermore, the meter can be configured to verification mode among other things, which improves the resolutions of the energy indications, thereby reducing the duration of test and verification.



Kamstrup

Kamstrup A/S
Industrivej 28, Stilling
DK-8660 Skanderborg
TEL: +45 89 93 10 00
FAX: +45 89 93 10 01
info@kamstrup.com
www.kamstrup.com

Functions

Display

The display is a liquid crystal display that makes it possible to read out the meter's registers. Which registers depend on the configuration.

The display configuration is constructed as two independent display lists. One for automatic shift function and one for manual shift function. The display is constructed of segments as shown on the figure.

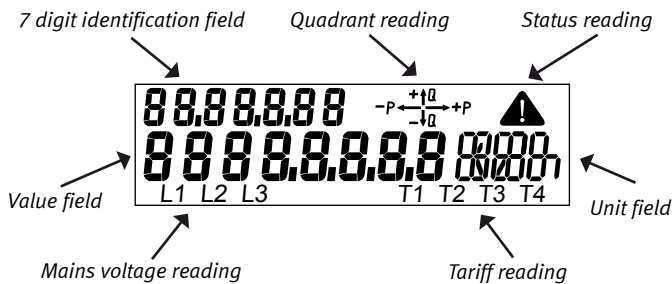

Value field

This field is used for displaying register values.

7 digit identification field

OBIS code identification of the value in the value field.

Quadrant reading

The total load is indicated.

Status reading

Indication of critical internal errors.

Unit field

This field is used for displaying the units of registers in the value field.

Tariff reading

Displays the active tariff, if tariffs is chosen.

Mains voltage reading

Indicates whether mains is connected.

The automatic shift function (scoll) changes between the selected readings in the required order every 10 sec. Historical data cannot be selected in the automatic shift function. Up to 16 readings can be selected.

The manual shift function through activation of the push button. The shift is effected when you release the push button. The order is optional, however it is not possible to opt out the legal readings. Up to 40 readings can be selected.

The meter automatically returns from manual shift function to automatic scroll function two min. after the last activation of the push button.

Calculation

The meter has one shunt per measuring system and resistance division for voltage measurement.

Like voltage drop, energy consumption is calculated as an expression of the current compared to the phase voltage and time.

The energy registration per measuring system is communicated to the meter's legal processor via the meter's internal bus system.

After correction the energies are summed in the main energy register.

Permanent memory

Measured and calculated data is safely stored in the memory (EEPROM). Data is stored by every change in energy register values.

Furthermore the below mentioned values are stored at the end of a debiting period.

Active energy A+
Active energy A-
Reactive energy R+
Reactive energy R-
Active energy A+ Tariff (T1-T4)
Reactive energy R+ Tariff (T1-T4)
Peak power P+max Tariff 1
Peak power P+max Tariff 1 Hour
Peak power P+max Tariff 1 Date
Peak power P+max Tariff 2
Peak power P+max Tariff 2 Hour
Peak power P+max Tariff 2 Date
Peak power P+max
Peak power P+max Date
Peak power P+max Hour
Accumulated peak power P+max akk
Date
Hour
Hour counter
Number of debiting periods
Power threshold counter
Pulse input

Optical reading

An optical infrared sender and receiver according to IEC 62056-21 is placed on the front of the electricity meter to the left.

This optical reading can be used to read data or to configure e.g. display set-up and pulse figure.

By using METERTOOL for kWh meter, the meter's 2-display readings can be configured. Furthermore the integration period, target date for debiting logger and debiting logging interval can be changed.

Finally the pulse input on the meter can be scaled and tariffs can be changed.

It is not possible to change the meter's legal data without breaking the verification seal.

Functions

S0 pulse output

Emits pulses of active energy at 1000 pulses per kWh. The pulses are emitted synchronously with the LED.

The S0-output is specified according to the standard DIN 43864.

The maximum voltage, which may be connected to the S0 output, is 27 VDC (at 1 kΩ), and the maximum current, which may be drawn through the output, is 27 mA.

The pulse duration is 30 msec.

Plug-in modules

If needed, Kamstrup 382 DIN can be extended by a plug-in module without subsequent reverification.

The module area communicates with the electricity meter's microprocessor via an internal data bus on the 6 pole internal connection.

This provides innumerable functional possibilities, extra pulse output, tariff modules, power supply modules and data communication via GSM/GPRS, PLC, TCP/IP or radio.

Kamstrup 382 H

This meter types has build in radio communication on the electricity meter's main circuit board.

This is to optimise the product and eliminates the need for mounting the radio module subsequently.

When the meter's module area is used with an other type of communication, the integrated radio communication will be deactivated.

Approved measuring data

The meter is type approved according to the Measurement Instrument Directive (MID) for active positive energy and according to national requirements for other energy types.

Approval

Type test according to
– Active positive energy

– Reactive energy as well as active negative energy

Norm

EN 50470-1
EN 50470-3

IEC 62052-11
IEC 62053-21
IEC 62053-23

Approval

Terminal according to

S0 pulse output according to

Optical reading according to

OBIS codes according to

Norm

DIN 43857

DIN 43864

IEC 62056-21
(IEC 61107)

IEC 62056-61

Technical data

Measuring principle

– Current

Single phased current measurement by current shunt

– Voltage

Single phased voltage measurement by voltage divider

Nominal voltage Un

1x230V ± 10%
2x230/400V ± 10%
3x230/400V ± 10%

Current Ib(Imax)

0.25-5(65)A
0.5-10(60)A
0.5-10(85)A
0.25-5(85)A

Class

A, B

Nominal frequency fn

50Hz ± 2%

Phase displacement

Unlimited

Operating temperature

-40°C - +70°C

Storage temperature

-40°C - + 70°C

Protective class

IP52

Protection class

II

Relative humidity

< 75% year's average at 21°C
< 95% less than 30 days/year, at 25°C

Weight

approx. 540 g

Application area

Indoors or outdoors in suitable DIN-rail meter cabinet

Internal consumption	382 GH
Current circuit	0.04 VA
Voltage circuit	1.4 VA, 0.1 W

Material

– Cover

Transparent polycarbonate

– Base

Glass reinforced polycarbonate

Data storage

EEPROM

> 10 years without voltage

Display

LCD, 7mm-digit height

(Value- and unit fields)

LCD, 5mm-digit height

(Identification readings)

LCD, 3mm-digit height

(voltage- and tariff-readings)

Meter constant

1000 imp./kWh,

1000 imp./kvarh

Real Time Clock (RTC) Accuracy

Typical 5 ppm at 23°C

Real Time Clock (RTC) backup Supercap

– life

> 10 years at normal operation

– operating

One week fully charged

S0-pulse diode

1000 imp./kWh, kvarh

Pulse duration 30 ms ±10%

S0-pulse output

1000 imp./kWh, kvarh

Pulse duration 30 ms ±10%

Short circuits level

4500 A²t

Connection modules

The meter can be supplied or retrofitted with the following inputs and outputs from main circuit board by connection modules, without reverification.

S0 Supply	Sends 24 V via a two wire and pulses, by pulling down the supply at 0 V at each pulse.
Data/pulse	Serial RS232 communication, open collector, 300/1200 baud. Maximum load (current).

Pulse value Imp/kWh, Imp/kvar	Pulse width/Pulse pause	
	30 msek	80 msek
1	105A	105A
10	105A	105A
100	105A	105A
1000	86A	32A
10000	8,6A	3,2A

M-Bus	Remote reading via M-Bus system.
2 tariffs	Tariff control via external 230 VAC.
Current Loop	Tariff control of 2 or 4 tariffs, CS and 230 VAC.
PLC	Remote reading via power line communication.
TCP/IP	Remote reading via TCP/IP communication.
GSM/GPRS	Remote reading via GSM/GPRS communication. Supports SMS reading.
Radio	Remote reading via radio communication. Build-in in 382 H.

Connections

Measuring circuit	1.5 – 25 mm ² B/C Elevating connections	Voltage terminal	0.25 – 1.5 mm ² , 5 mm Cable terminal forks
Screws	Pz 2 or straight slot Torque 2.5 – 3 Nm	Screws	PH 2 or straight slot Torque 1Nm

Typical accuracy charts

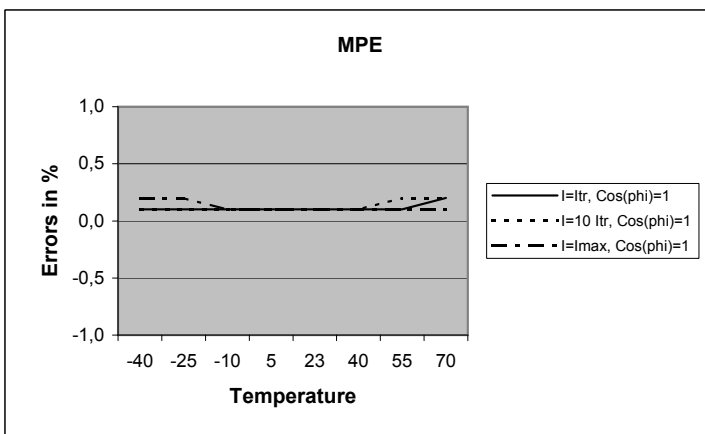
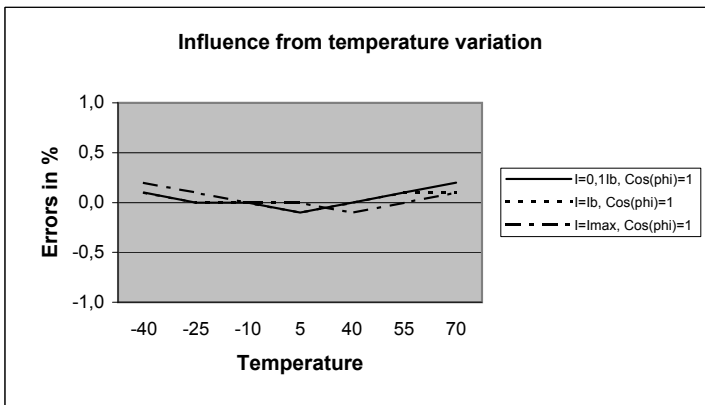
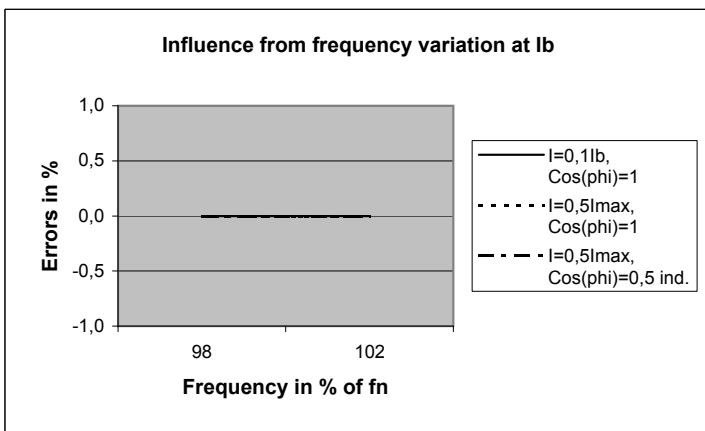
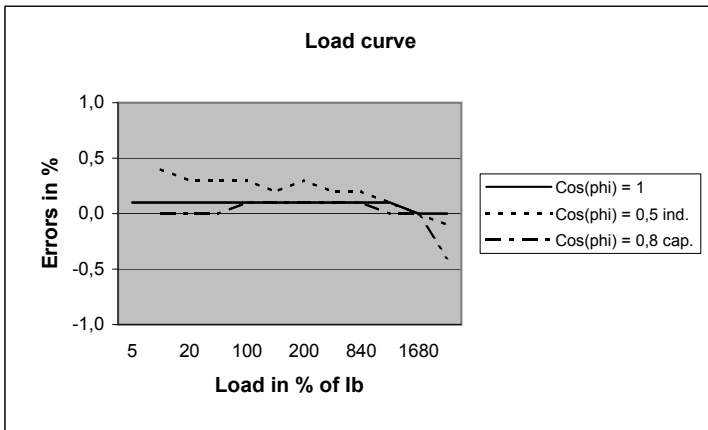

MPE (Maximum permissible error)
 Composed error of
 -Load
 -Voltage variation
 -Frequency variation
 -Temperature variation

Ordering details

	684-	X ₁	X ₂	X ₃	X ₄	X ₅	X ₆	X ₇	X ₈	X ₉	X ₁₀
X₁ Phases											
3x230/400V		3									
X₂ Current											
0.25-5(65)A			4								
0.5-10(60)A			6								
0.5-10(85)A			7								
0.25-5(85)A			8								
X₃ Class											
Class A				A							
Class B				B							
X₄ Generation											
Basis DIN					G						
Communication DIN RF					H						
X₅ Energy type											
A+						1					
A+/A-						2					
A+/A-/R+/R-						4					
X₆ HW option											
RTC (Supercap)							3				
RF S incl. Supercap							6				
RF K incl. Supercap							7				
X₇ Tariff configurable											
No tariff								1			
2-tariff								2			
Configurable								3			
4-tariff								4			
X₈ X₉ X₁₀ Country code											
DK											010
RUS											025
ES											031
NO											040
LV											045
LIT											049
GB											050
A											055
CH-I											059
EST											061
CH-D											063
PL											064
CH-F											065
ISL											067
DE											070
NL											080
FIN											084
SE											090

Configuration 1 (A-B-CCC-DD-E)

- A** Decimals displayed (locked)
- B** LED configuration (locked)
- CCC** Module
- DD** Input / output configuration
- E** Integration period

	A	B	C	C	C	D	D	E
A Decimals in display								
7.0	1							
6.1	2							
B LED configuration								
LED switched off without consumption		1						
LED switched on without consumption		2						
CCC Module								
No module, OK				000				
S0 Supply module, SK				001				
Data/pulse module, RK				003				
M-Bus module, MK				005				
Tariff module, 2 tariff, 230 V, WK				008				
Tariff module, 4 tariff, 230 V, CS, PK				018				
S0 Pulse module				021				
PLC module, router, ext. RTC				039				
IP101i, TCP/IP module				040				
Radio module, high power				043				
PLC module, S				050				
Radio module, router, S				052				
GSM6i				053				
S input/output				055				
DD Input/output configuration								
Contact Kamstrup							XX	
E integration period								
5 min.								1
15 min.								2
30 min.								3
60 min.								4

Configuration 2 (FFF-GG-HH-I)

- FFF** Display configuration – **Contact Kamstrup for further information.**
- GG** Target date
- HH** Debiting logging interval
- I** Various

Configuration 2 (FFF-GG-HH-I)

	G	G	H	H	I
GG Target date					
External controlled		00			
1.		01			
2.		02			
3.		03			
4.		04			
5.		05			
6.		06			
7.		07			
8.		08			
9.		09			
10.		10			
11.		11			
12.		12			
13.		13			
14.		14			
15.		15			
16.		16			
17.		17			
18.		18			
19.		19			
20.		20			
21.		21			
22.		22			
23.		23			
24.		24			
25.		25			
26.		26			
27.		27			
28.		28			
HH Debiting logging interval					
None (external controlled)				00	
Monthly				01	
Every second month, January				02	
Every second month, February				03	
Every third month, January				04	
Every third month, February				05	
Every third month, Marts				06	
Half-yearly, January				07	
Half-yearly, February				08	
Half-yearly, Marts				10	
Half-yearly, April				11	
Half-yearly, May				12	
Half-yearly, June				13	
Yearly, January				14	
Yearly, February				15	
Yearly, Marts				16	
Yearly, April				17	
Yearly, May				18	
Yearly, June				19	
Yearly, July				20	
Yearly, August				21	
Yearly, September				22	
Yearly, October				23	
Yearly, November				24	
Yearly, December				25	
I Various					
30ms, pulses					1
80ms, pulses					3

Configuration 3 (JJ-K-LL-M-NN)

- JJ** Disconnect setup
- K** Peak power
- LL** GMT
- M** Available
- NN** Unit pulse input

	J	J	K	L	L	M	N	N
JJ Disconnect setup								
None		00						
K Peak power								
Peak power standard			0					
Peak power for tariff 1			1					
Peak power for tariff 2			2					
LL GMT								
0 London					00			
1 DK-D-F-E					01			
2 FIN					02			
3					03			
4					04			
5					05			
6					06			
7					07			
8					08			
9					09			
10					10			
11					11			
12					12			
-11					13			
-10					14			
-9					15			
-8					16			
-7					17			
-6					18			
-5					19			
-4					20			
-3					21			
-2					22			
-1					23			
M Available								
None						0		
NN Unit pulse input								
None								00
kWh								01
m ³								02
L								03

Configuration 4 (OOO-PPP-QQ)

- OOO** Tariff control table / Holiday table / Table for summer/normal time plan
PPP Summer/normal time table
QQ Protocol

	O	O	O	P	P	P	Q	Q
OOO Tariff control table								
Contact Kamstrup			XXX					
PPP Summer/normal time table								
None						000		
001 EU						001		
QQ Protocol								
None								00

Configuration 5 (RRR)

- RRR** Frequency – transmitting power

	R	R	R
RRR Frequency – transmitting power			
Ingen radio			000
EU 310 RF S			310
EU 311 RF S			311
EU 312 RF S			312
EU 319 RF K			319
SE 320 RF S			320
SE 321 RF S			321
SE 322 RF S			322
SE 328 RF K			328
NO 330 RF S			330
NO 339 RF K			339
DK 340 RF S			340
DK 349 RF K			349

Installation

Connect the meter in accordance with the installation diagram on the meter's type label.

Depending on the configuration a fixed value will be displayed, or the display will change between selected indications every 10 seconds.

It is possible to change the display reading manually by activating the push button on the meter.

The available readings will depend on the meter's configuration.

Connection diagrams

The valid connection diagram appears from the type label on the front of the meter.

3-phase, 4-wire

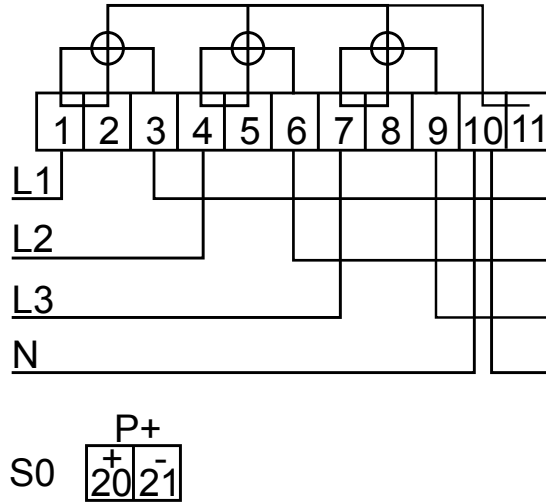

Security and installation guide lines

The meter shall only to be used for measuring electrical energy and shall operate within the specified values only.

The meter must be switched off when working on it. It can be highly dangerous to touch the meter parts when the meter is switched on.

Therefore, the relevant safety fuse must be removed and kept in a place where unauthorised persons cannot insert it.

Current local standards, guidelines, regulations and instruction must be observed. Only authorised personnel are permitted to install electricity meters. Meters for direct connection must be protected against short circuit by a backup fuse in accordance with the maximum current stated on the meter.

The meter constant LED blinks proportionally to the consumed active energy.

Only authorised personnel must break the sealing.

Sealing

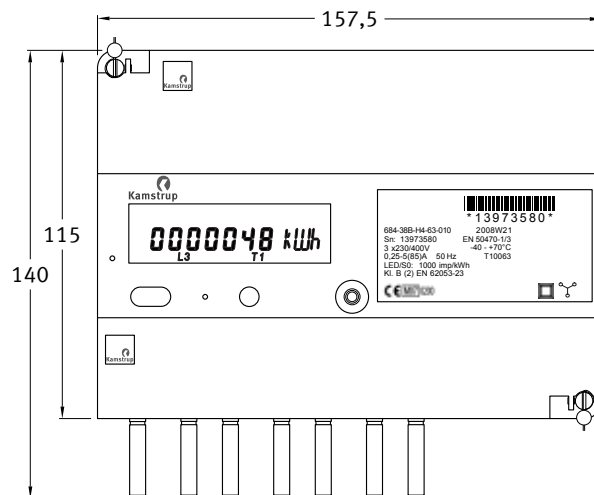

Accessories

Modules

S0 Supply module	SK	68 50 001
Data/pulse module, relay output	RK	68 50 003
M-Bus module	MK	68 50 005
Tariff module, 2 tariffs, 230 VAC	WK	68 50 008
Tariff module, 4 tariffs, 230 VAC, current loop	PK	68 50 018
S0 Pulse module		68 50 021
PLC module, router, external RTC	PO	68 50 039
IP101i, TCP/IP module	IK	68 50 040
Radio module, router, high power	QR	68 50 043
PLC S	PP	68 50 050
S RF router		68 50 052
GSM6i		68 50 053
S input / output		68 50 055

Software

Configuration SW, METERTOOL for kWh meter		68 99 570
---	--	-----------

Various

Optical reading head with 9-pole-t Dsub connector		66 99 102
Optical reading head with USB connector		66 99 099
Contact plugs, 50 pcs.		68 50 102