

# SVM P4 Pulse Counter

## DATA SHEET

- Pulse counter with three registers
- Flow rate calculated for one pulse input
- 230VAC mains supply
- Built-in M-Bus
- Monthly registers
- Spacious terminal blocks
- Robust cable glands



## Application

P4 is a pulse counter with three pulse inlets, and is used to collect pulses from water meters, gas meters, electricity meters or other meters that emit pulses.

The pulses are accumulated in three separate registers in P4, which in turn can be remotely read with 2-wire M-Bus. The pulse values are specified upon order and are set either as a pulse factor (multiplier) or as a pure pulse counter.

Pulse input 1 and 2 are set by the same factor, while input 3 is set separately. Input 3 is also used to calculate the momentary flow rate. Monthly values are stored for each pulse register along with any error code, for up to 37 months.

P4 is mains supplied with 230VAC, equipped with superior cable glands and strain-reliefs and offers spacious terminal blocks for easy installation!



# SVM P4 Pulse Counter

## DATA SHEET



## Function

P4 offers three separate pulse register in which the pulses can be converted by a multiplier and then accumulated. The basic unit of P4 is always [m<sup>3</sup>] (1000 l).

**Example 1:** The pulse value is 25 [l / p] and P4 receives 50 pulses. The register will show  $25 \times 50/1000 = 1.25$  [m<sup>3</sup>].

**Example 2:** The pulse value is 1000 [l / p] and P4 receives 37 pulses. The register will show  $1000 \times 37/1000 = 37$  [m<sup>3</sup>]. By setting the pulse value to 1000, the P4 acts as a pure pulse counter and may be used for any unit, kWh, USG etc.

**NOTE!** The pulse value is specified upon order, and can only be changed by using the service program FlexServ.

All three registers can be read directly on the LCD or via M-Bus. Pulse input 3 also reports momentary flow rate, which also can be read on the LCD or via M-Bus. P4 can be equipped with a relay option board, FCRC, enabling the pulse inputs 1 and 2 to receive 50 pulses.

## Display

P4 is equipped with an LCD. With the push button it is easy to navigate through the pulse registers and the historical values.

P4 have the following display sequence:

Sequence	Description
10	Pulse register 1
11	Pulse register 2
12	Pulse register 3
13	Momentary flow rate, pulse input 3
14	Display test
15	Error code
20	Total operating time (hours)
21	Date
22	RTC
23	Accumulated time for current error (minutes)
24	Total accumulated error time (minutes)
30	Primary communication address
A0	Secondary communication address
b0	Meter number S/N
40	Monthly register, date (YYMMDD)
41	Not used
42	Pulse register 3
43	Not used
44	Pulse register 1
45	Pulse register 2
46	Error code, at date of storage
47	Accumulated error time (minutes)



Fig.1, P4 LCD showing pulse register 1

Table 1, P4 display sequence

# SVM P4 Pulse Counter

## DATA SHEET



## Delivery

P4 is delivered in Transport mode where only the RTC is active. This means that the P4 can be stored for several months without affecting the back-up battery life. To put the P4 in operation see Service/Commissioning below.

## Service/Commissioning

Press and hold the push button for about 5 seconds in order to exit Transport mode and put the meter in Service mode. In Service mode it is possible to set the RTC, the date and the primary communication address, cf. Table 2 below.

The push button has a dual function. When the button is pressed and held the meter toggles through the service sequence without any values being changed. When the button is pressed and released again, the value of the current flashing digit is changed one step (+1). When all parameters are properly set, exit the Service menu through sequence "0A" by changing the value from 0 to 1 and then press and hold the push button until sequence 10, normal mode, is displayed. The pulse counter P4 is now ready for use.

Sequence	Description
00	RTC [HHMM]
01	Date [YYMMDD]
06	Primary communication address [0000-0255]
0A	Exit Service mode [0=return to "00", 1=go to "10" Normal mode]

Table 2, P4 service sequence

## Option boards

P4 can be equipped with a Relay option board, FCRC, to isolate the pulse inputs. The FCRC option board also enables pulse inputs 1 and 2 to be connected to S0 pulses. For more information, cf. The Relay option board data sheet.

Other option boards may not be installed in P4.

## Connections

Use only the marked terminals in Fig. 2 below. The other terminals have no function.

**Note!** Incorrect connection may damage the P4.

P4 is equipped with separate terminals for the mains cable.

Marking on terminal	Signal
IN -	Pulse input 1 and 2, common signal zero (GND)
IN 1	Pulse input 1 signal
IN 2	Pulse input 2 signal
+	Pulse input 3 signal
-	Pulse input 3 signal zero (GND)
M-BUS	M-Bus, polarity insignificant
M-BUS	M-Bus, polarity insignificant

Table 3, P4 connections

# SVM P4 Pulse Counter

## DATA SHEET



## Installation

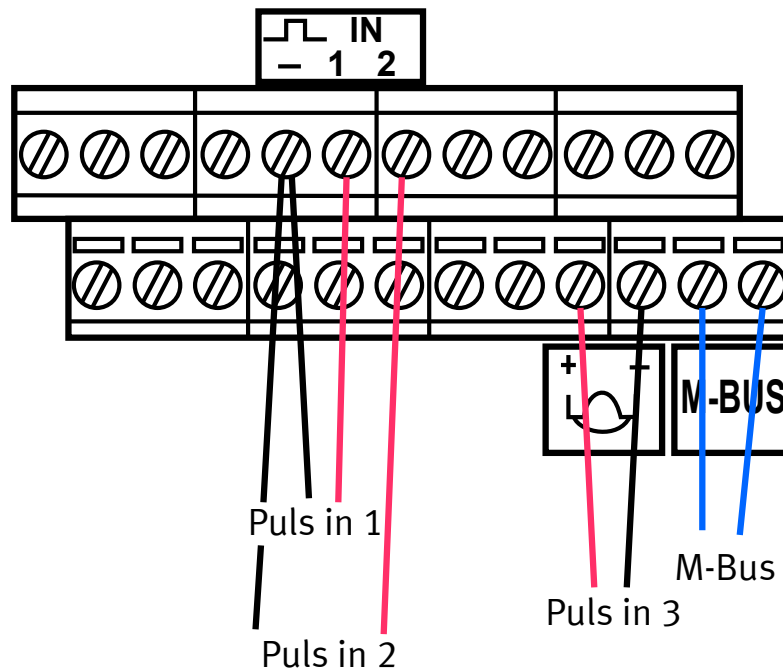

Fig.2, P4 terminals

## Technical data

### Pulse inlets 1, 2 and 3

– Frequency	max 12 Hz
– Pulse length	min 40 ms
– Voltage	max 3 V
– Cable length	max 15 m
– Pulse value	1, 2.5, 10, 25, 100, 250, 1000 or 2500 l/p

### Power supply

– Mains	230 VAC ± 10%, 45-65 Hz, back-up battery 3.6V
---------	---

### Data output

– M-Bus (EN1434-3)	OPTO-interface (EN60870-5) and 2-wire bus connection (screw terminals)
--------------------	--

### Ambient temperature

– Operation	+5°C to +55°C
– Storage/ transport	-20°C to +70°C

### Protection class

IP54

### Environmental class

C acc. to EN1434

### Display

LCD, 7 + 2 digits

# SVM P4 Pulse Counter

## DATA SHEET



## Dimensions

All dimensions are in mm.

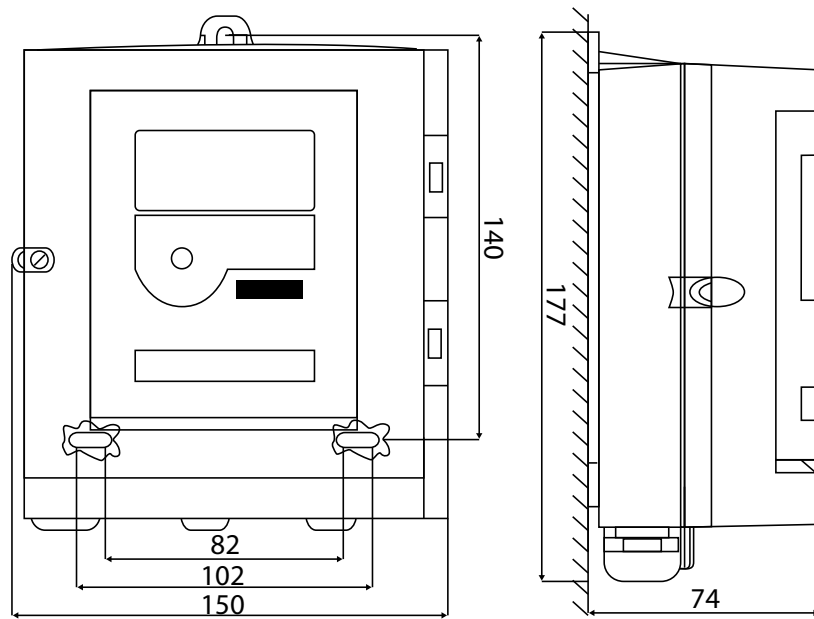

Fig.3, Dimensions

## Mounting

P4 is designed for wall mounting.

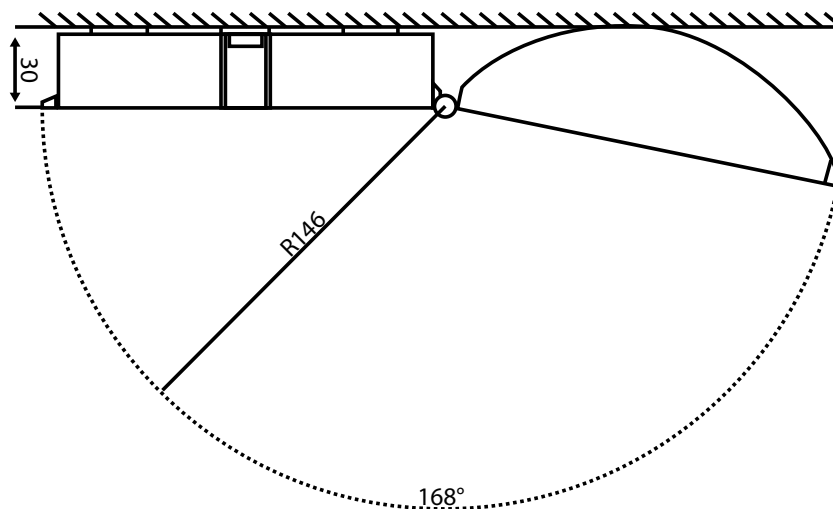

Fig.4, Wall mounting

# SVM P4 Pulse Counter

## DATA SHEET



### P4 Article number ABCDEFGHIJKLM

SVM P4	A	B	C	D	E	F	G	H	I	J	KLM
<b>Sensors</b>											
None	1										
<b>Power supply</b>											
Mains 230 VAC (w. back-up battery)	3										
<b>Pulse value inlet 3</b>											
Pulse inlet 3 2.5 l/p			1								
Pulse inlet 3 25 l/p			2								
Pulse inlet 3 250 l/p			3								
Pulse inlet 3 2500 l/p			4								
Pulse inlet 3 1 l/p			5								
Pulse inlet 3 10 l/p			6								
Pulse inlet 3 100 l/p			7								
Pulse inlet 3 1000 l/p			8								
<b>Flow unit</b>											
m <sup>3</sup> /h				1							
<b>Configuration</b>											
Standard					-						
Customer number – Separate specification needed					E						
Special – Separate specification needed					S						
<b>Pulse value inlet 1/2</b>											
Pulse inlet 1/2 2,5 l/p						A					
Pulse inlet 1/2 25 l/p						B					
Pulse inlet 1/2 250 l/p						C					
Pulse inlet 1/2 2500 l/p						D					
Pulse inlet 1/2 1 l/p						E					
Pulse inlet 1/2 10 l/p						F					
Pulse inlet 1/2 100 l/p						G					
Pulse inlet 1/2 1000 l/p						H					
<b>Display</b>											
No backlight. With Opto and M-Bus							1				
<b>Montage</b>											
Wall mounting								0			
<b>Connections</b>											
Both connectors mounted									1		
<b>Communication</b>											
M-Bus, 300 baud										1	
M-Bus, 2400 baud										2	
<b>Country</b>											
English standard											300

### P4 Article number key

To acquire the correct article number, just fill out the blanks.

P4	A	B	C	D	E	F	G	H	I	J	KLM
	1	3		1			1	0	1		300