

Technical Description

•

ULTRAFLOW® 54  
DN150-300

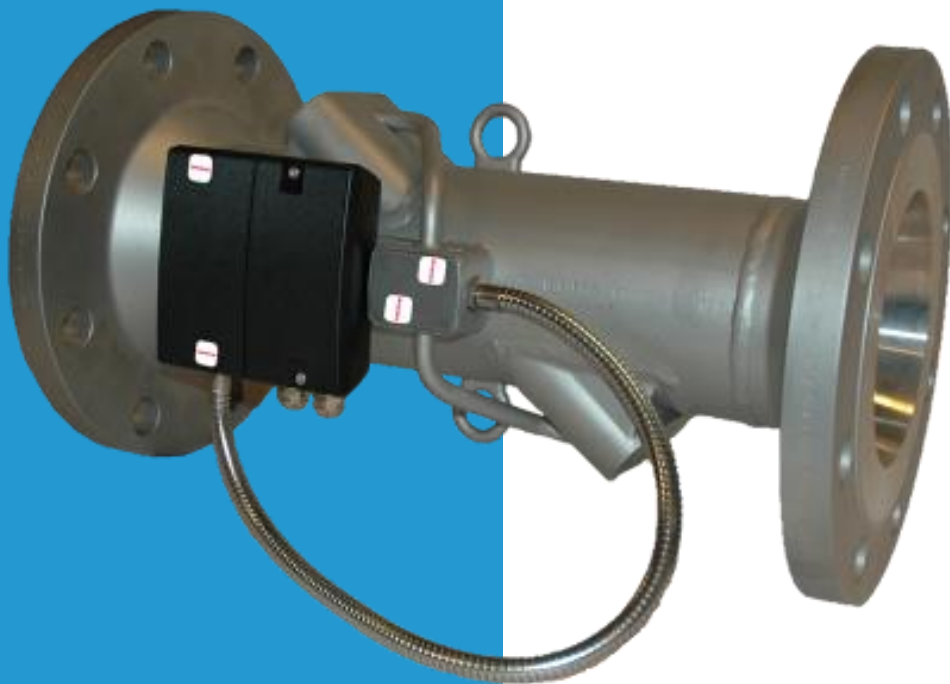



## Contents

<b>1</b>	<b>Introduction .....</b>	<b>6</b>
1.1	Pioneering work and continuous development .....	6
1.2	Modular meter set-up for maximum flexibility .....	6
1.3	General description .....	6
<b>2</b>	<b>Technical data .....</b>	<b>8</b>
2.1	Approved meter data .....	8
2.2	Electrical data .....	8
2.3	Mechanical data .....	9
2.4	Flow data .....	10
2.5	Materials .....	10
<b>3</b>	<b>Type overview .....</b>	<b>11</b>
<b>4</b>	<b>Ordering details .....</b>	<b>12</b>
4.1	Type numbers of ULTRAFLOW® 54 for MULTICAL® .....	12
4.2	Type numbers of separate ULTRAFLOW® 54 .....	12
	Ordering details of separate ULTRAFLOW® 54 .....	13
4.2.1	Type numbers of output and supply modules .....	13
4.2.2	Programming options of meter factor and pulse durations .....	14
4.2.3	Accessories .....	15
4.3	Accessories .....	15
4.3.1	Cables .....	16
4.3.2	Cable Extender Box .....	16
<b>5</b>	<b>Dimension sketches .....</b>	<b>17</b>
5.1	ULTRAFLOW® 54 DN150-300 .....	17
5.2	Cable Extender Box .....	18
<b>6</b>	<b>Installation .....</b>	<b>19</b>
6.1	Guidelines for dimensioning and operating conditions .....	19
6.1.1	Introduction .....	19
6.1.2	Dimensioning .....	20
6.1.3	Operating conditions .....	20
6.1.4	Operating pressure .....	22
6.1.5	Pressure loss .....	24
6.6.16.2	Connections and cable length .....	25
6.6.2	6.3 Flow sensor position (Inlet/Outlet) .....	25
6.7.1	6.4 Insulation .....	25
6.5	Inlet prerequisites .....	27
6.6	Orientation of ULTRAFLOW® 54 .....	28
	General recommendations .....	28
	Recommendations for heat, cooling and bi-functional heat/cooling installations .....	28
6.7	Mounting of ULTRAFLOW® 54 electronics box .....	29
	Orientation of flow sensor electronics box .....	30

	Wall-mounting of the electronics box .....	31
6.9	Mounting of Cable Extender Box .....	31
6.10	Maintenance and service during operation .....	31
6.11	Installation examples (mechanical) .....	32
	Mounting ULTRAFLOW® 54 in lifting ring.....	32
	Insulation of ULTRAFLOW® 54 (DN150-300).....	33
6.8.1 6.12	Electrical connections to MULTICAL® .....	35
	ULTRAFLOW® 54 and MULTICAL®, galvanically coupled .....	35
	ULTRAFLOW® 54 and MULTICAL®, galvanically separated.....	35
6.11.1	Cable length .....	37
6.11.2	Connection of power supply .....	38
6.12.1	6.12.4.1 Battery supply.....	38
6.12.2	6.12.4.2 Mains supply modules .....	38
6.12.3	6.12.4.3 Mains supply cable .....	39
6.12.4	6.12.4.4 Cable screw connections .....	40
	6.12.4.5 Change of supply unit .....	40
	Electrical connection of Cable Extender Box.....	40
6.6.13 6.12.3	Installation examples (electrical) .....	41
	Example of connection of ULTRAFLOW® 54 and MULTICAL® .....	41
6.13.1	Calculator with two flow sensors .....	42
6.13.2	Electric welding .....	42
6.13.3	Operational check.....	42
6.14	Operational check.....	42
<b>7</b>	<b>Functional description .....</b>	<b>43</b>
7.1	Flow measurement with ultrasound .....	43
7.2	Signal path, flow calculation and flow profiles.....	43
7.3	Function of ULTRAFLOW® .....	46
7.4	Pulse emission.....	47
7.6.1 7.6.2 7.6.5	Supply and power consumption of ULTRAFLOW® .....	47
7.6	Pulse output of ULTRAFLOW® .....	48
	Galvanically coupled .....	48
	Galvanically separated.....	49
7.7	Interface connector/serial data .....	51
7.8	Test mode .....	52
7.9	Externally controlled start/stop .....	52
7.10	Calibration using serial data and externally controlled start/stop.....	53
7.11	Accuracy .....	54
<b>8</b>	<b>Calibration, adjustment and sealing of ULTRAFLOW® 54.....</b>	<b>56</b>
8.1	Technical data for ULTRAFLOW® .....	56
8.2	Electrical connection .....	57
8.3	Suggested test points .....	58
8.4	Optimization in connection with calibration.....	59
8.5	Pulse Tester.....	60

	Technical data of Pulse Tester.....	60
	Hold-function .....	62
	Push-button functions .....	62
	Using Pulse Tester .....	62
	Spare parts .....	63
	Battery replacement .....	63
8.5.1	8.6 Adjustment of ULTRAFLOW® flow sensors with Kamstrup software.....	64
8.5.2		
8.5.3	8.7 Sealing and marking.....	64
8.5.4		
8.5.5	<b>9 Software for Kamstrup heat/cooling meters .....</b>	<b>67</b>
8.5.6		
	<b>10 Approvals .....</b>	<b>68</b>
	10.1 MID and DK-BEK 1178 – 06/11/2014.....	68
	10.2 CE-Marking .....	68
	10.3 Declaration of conformity (EU) .....	68
	<b>11 Troubleshooting .....</b>	<b>69</b>
	<b>12 Disposal .....</b>	<b>70</b>
	<b>13 Technical documentation .....</b>	<b>71</b>

# 1 Introduction

## 1.1 Pioneering work and continuous development

Since 1991 Kamstrup has provided static ultrasonic flow sensors for heat meters and is among the pioneering manufacturers of this technology. The stand-alone flow sensors ULTRAFLOW® are the trademark of the Kamstrup static flow sensors based on the ultrasonic measuring principle. The proven long-term accuracy and durability have gained our flow sensors a reputation for reliability and quality. Ongoing development has continuously improved the whole performance of Kamstrup flow sensors. The pressure loss has, for example, been continuously reduced, while the dynamic range could still increase. Furthermore, various smart features like the ability to mount a temperature sensor in the outlet of flow sensors with sizes up to  $q_p$  10 m<sup>3</sup>/h have been added.

## 1.2 Modular meter set-up for maximum flexibility

ULTRAFLOW® is known as a separate static flow sensor. The modular composition of our heat and cooling meter set-up consisting of separate flow sensor, calculator and temperature sensor set adds degrees of flexibility to your installation, thereby accommodating most needs. In cases where separation of flow sensor and calculator is required during installation, the cable to the calculator can easily be disconnected and connected again. This cable between calculator and flow sensor is in most cases also comparatively easily changeable, underlining the intelligent and easy-to-handle design of Kamstrup products. In addition, you can exchange only one of your sub-assemblies, which minimizes unforeseen costs in case of a calculator upgrade or replacement of either part. The split meter solution allows cable lengths of 2.5 m, 5 m and 10 m as standard and enables even extra-long cables of up to 110 m to MULTICAL®. For further information about our separate calculators MULTICAL® 603 and MULTICAL® 803, please consult Kamstrup doc. no. 5512-2029\_GB and 5512-2360\_GB.

Whether you choose to install the separate ULTRAFLOW® or the flow sensors connected to our compact calculators, you can be assured by the fact that all our flow sensors are based on the same platform. The ULTRAFLOW® technology has been utilized in the basic design of our other flow sensors integrated in our compact meters like MULTICAL® 303 and MULTICAL® 403 ensuring equally proven accuracy, durability and serviceability. For further information about our compact meters MULTICAL® 303 and MULTICAL® 403, please consult Kamstrup doc. no. 5512-2701\_GB and 5512-1689\_GB.

## 1.3 General description

The flow sensor program ULTRAFLOW® 54 (DN150-300) is particularly designed as a volume flow sensor with water as the thermal energy bearing medium in combination with MULTICAL® 603 and MULTICAL® 803 and a set of TemperatureSensor 83. The static flow sensors of stainless steel come with a rational design, where the electronics is configurable and even programmable depending on the application. This simplifies e.g. an installation with extra-long cables, because the required output modules can already be integrated on demand. These flow sensors are both well protected with respect to condensation but can also withstand high temperatures. The flow sensors can therefore be operated at water temperatures  $\theta_q$  from 2 °C to 150 °C and are approved according to EN 1434 for heat, cooling and bi-functional heat/cooling installations. With sizes from  $q_p$  150 m<sup>3</sup>/h to 1000 m<sup>3</sup>/h ULTRAFLOW® 54 (DN150-300) is therefore particularly suitable for distribution nets of heat or cooling energy.

ULTRAFLOW® employs microprocessor technology. The flow is measured using bidirectional ultrasonic technique based on the transit time method. Two sets of transducers with a diagonal ultrasonic path along the cross section of the flow sensor ensure a correct measurement within the working range of the flow sensor. All circuits for calculating and measuring are collected on a single board, providing a compact and rational design in addition to an exceptionally high level of measuring accuracy and proven long-term stability. A three-wire signal cable is used to connect ULTRAFLOW® directly to separate MULTICAL® calculators by a cable with a length of up to 10 m. This cable is used to supply the flow sensor from the calculator and also to send volume proportional pulses to the calculator.

When there is a need to extend the cable between ULTRAFLOW® and MULTICAL®, a Cable Extender Box can be used, which is mounted between ULTRAFLOW® and MULTICAL® to extend the cable length up to 30 m. Note that ULTRAFLOW® and MULTICAL® in these cases are galvanically connected. If ULTRAFLOW® shall be connected to other equipment (e.g. other brands of calculators), it must normally be connected through a galvanically separated output module and a supply

by its own. If ULTRAFLOW® is connected to another calculator with a different meter factor than the one supplied by ULTRAFLOW®, the output modules feature a wide range of programmable meter factor and pulse length settings. In addition, a galvanically separated output module enables a cable length of up to 110 m between ULTRAFLOW® and MULTICAL®, which is required in some installations.

## 2 Technical data

ULTRAFLOW® 54 DN150-300

### 2.1 Approved meter data

#### MID designation

Mechanical environment	M1 and M2
Electromagnetic environment	E1 and E2
Climatic environment	5...55 °C, condensing, closed location (indoors installation)
Accuracy class	2 and 3

#### EN 1434 designation

Environmental class	C
Fast response meter (sub-assembly flow sensor)	Volume sampling interval $\leq 1$ s

### 2.2 Electrical data

Internal supply voltage	3.6 VDC $\pm$ 0.1 VDC
Supply, galvanically coupled output module (Y=1)	Powered by MULTICAL®
Supply, galvanically separated output module (Y=2) <sup>1)</sup>	

<sup>1)</sup> It is possible to use battery supply in combination with output module (Y=2), e.g. for temporary supply of flow sensors installed at construction sites.

Mains supply	230 VAC $\pm$ 15/-30 %, 50 Hz 24 VAC $\pm$ 50 %, 50 Hz
Power consumption	< 1 W
Backup	Integral SuperCap eliminates interruptions due to short-term power failures
Supply, galvanically separated output module (Y=3)	
Battery	3.65 VDC, D-cell lithium
Battery life-time (replacement interval)	6-years @ $t_{BAT} < 30$ °C
Mains supply	230 VAC $\pm$ 15/-30 %, 50 Hz 24 VAC $\pm$ 50 %, 50 Hz
Power consumption	< 1 W
Backup	Integral SuperCap eliminates interruptions due to short-term power failures
Signal cable length, from flow sensor electronics box with galvanically coupled output module (Y=1)	Max 10 m (powered by MULTICAL®)
Signal cable length, from flow sensor electronics box with galvanically separated output module (Y=2 and 3)	Depending on calculator (use of own supply in ULTRAFLOW®). Max 100 m when connected to MULTICAL® (Y = 2). See <i>paragraph 6.12.2</i> for applications with MULTICAL®
Signal cable length, Cable Extender Box	Depending on calculator. Max 30 m when connected to MULTICAL® 603 or 803
Electromagnetic environment	Fulfils EN 1434:2015 class C, MID E1 and E2

## 2.3 Mechanical data

Accuracy class	2 or 3	
Electromagnetic environment	Fulfils EN 1434 class C, MID E1 and E2	
Mechanical environment	MID M1 and M2	
Ambient conditions	5...55 °C, closed location (indoor installation)	
Protection class		
Flow sensor	IP67 <sup>2)</sup>	When installed properly. See paragraph 6.7
<sup>2)</sup> IP classification is limited by the electronics box, which can be installed with a suitable distance to the flow sensor, if necessary e. g. due to permanent condensation.		
Cable Extender Box	IP65	
Medium in flow sensor	Water - recommended water quality as in CEN TR 16911 and AGFW FW510	
Temperature of medium $\theta_q$	2...150 °C or narrower range (depending on configuration; see marking)	At medium temperatures above 90 °C or below ambient temperature, the electronics box must be wall mounted or mounted via the enclosed bracket.
Storage and transport temperature, empty sensor	-25...60 °C	
Pressure stage	PN25, PS25 (DN150-250) or PN16, PS16 (DN300) (depending on type)	
Straight inlet requirement	OD (according to EN 1434) <sup>3)</sup>	
<sup>3)</sup> Types FCCN, FDCN, FECR, FFCR, FGDS acc. to EN 1434:2007/AC2007, EN 1434:2015+A1:2018 and EN 1434:2022 (2022-04). Types FECN, FECR, FFCR, FGCR acc. to EN 1434:2007/AC2007 and EN 1434:2015+A1:2018.		
Installation angle	Horizontally, vertically and at an angle <sup>4)</sup>	
<sup>4)</sup> ULTRAFLOW® 54 is normally installed horizontally, with the lifting rings oriented vertically. The ultrasound paths in the flow sensor tube will thus be vertical, which is optimal in connection with possible stratification of the medium.		

## 2.4 Flow data

Nom. flow $q_p$ [m³/h]	Meter factor <sup>1)</sup> [p/l]	Dynamic range $q_p:q_i$	$q_s:q_p$	Flow @125 Hz <sup>2)</sup> [m³/h]	Min. cut off [l/h]
150	1	100:1	2:1	450	750
250	0.6	100:1	2:1	750	1250
400	0.4	100:1	2:1	1125	2000
400	0.4	100:1	2:1	1125	2000
400	0.4	100:1	2:1	1125	2000
600	0.25	100:1	2:1	1800	3000
600	0.25	100:1	2:1	1800	3000
1000	0.15	100:1	2:1	3000	5000
1000	0.15	100:1	2:1	3000	5000

<sup>1)</sup> Standard meter factor. Appears from ULTRAFLOW® label. For other meter factors see paragraph 4.

<sup>2)</sup> Saturation flow 125 Hz. Max. pulse frequency is maintained at higher flow.

Table 1. Flow data.

## 2.5 Materials

### Wetted parts

Housing, flanged	Stainless steel, W.no. 1.4301
Transducer seats	Stainless steel, W.no. 1.4308
Transducer base	Titanium
Gaskets	Fibre

### Electronics box

Base, cover	Thermoplastic, 10 % glass fibre-reinforced Polycarbonate (PC 10 % GF)
Fitting hardware, bracket for electronics box	Thermoplastic, Polyphenylene sulphide (PPS) 40 % GF

### Signal cable (optional for separate ULTRAFLOW® 54)

Silicone cable (3 x 0.5 mm<sup>2</sup>)

### Power supply cable 24/230 VAC (optional when selecting supply module)

Cable with Polyvinylchloride (PVC)-mantle (2 x 0.75 mm<sup>2</sup>)

### Housing, Cable Extender Box

Base, cover	Thermoplastic, Acrylonitrile butadiene styrene (ABS)
-------------	--

### 3 Type overview

Nom. flow $q_p$ [m <sup>3</sup> /h]	Installation dimensions		
	150	DN150x500 mm	
250	DN150x500 mm		
400	DN150x500 mm	DN200x500 mm	DN250x600 mm
600	DN200x500 mm	DN250x600 mm	
1000	DN250x600 mm	DN300x500 mm	

Flange facing type B, raised face according to EN 1092-1

*Table 2. Type overview.*

## 4 Ordering details

### 4.1 Type numbers of ULTRAFLOW® 54 for MULTICAL®

The table below shows a list of type numbers for ULTRAFLOW® 54 ordered with MULTICAL®

Type number	q <sub>p</sub> [m <sup>3</sup> /h]	q <sub>i</sub> [m <sup>3</sup> /h]	q <sub>s</sub> [m <sup>3</sup> /h]	Dynamic range q <sub>p</sub> :q <sub>i</sub>	Connection [mm]	PN, PS [bar]	Length [mm]	Material (flow sensor housing)
65-5- FCCN -XXX	150	1.5	300	100:1	DN150	25, 25	500	Stainless steel
65-5- FDCN -XXX	250	2.5	500	100:1	DN150	25, 25	500	Stainless steel
65-5- FECN -XXX	400	4	800	100:1	DN150	25, 25	500	Stainless steel
65-5- FECP -XXX	400	4	800	100:1	DN200	25, 25	500	Stainless steel
65-5- FECR -XXX	400	4	800	100:1	DN250	25, 25	600	Stainless steel
65-5- FFCP -XXX	600	6	1200	100:1	DN200	25, 25	500	Stainless steel
65-5- FFCR -XXX	600	6	1200	100:1	DN250	25, 25	600	Stainless steel
65-5- FGCR -XXX	1000	10	2000	100:1	DN250	25, 25	600	Stainless steel
65-5- FGDS -XXX	1000	10	2000	100:1	DN300	16, 16	500	Stainless steel

XXX - code for final assembly, approvals etc. - determined by Kamstrup.

Table 3. Type numbers of ULTRAFLOW® 54 for MULTICAL®.

### 4.2 Type numbers of separate ULTRAFLOW® 54

Type number	q <sub>p</sub> [m <sup>3</sup> /h]	q <sub>i</sub> [m <sup>3</sup> /h]	q <sub>s</sub> [m <sup>3</sup> /h]	Dynamic range q <sub>p</sub> :q <sub>i</sub>	Connection [mm]	PN, PS [bar]	Length [mm]	Material (flow sensor housing)
65-5- FCCN -YZ -XXX	150	1.5	300	100:1	DN150	25, 25	500	Stainless steel
65-5- FDCN -YZ -XXX	250	2.5	500	100:1	DN150	25, 25	500	Stainless steel
65-5- FECN -YZ -XXX	400	4	800	100:1	DN150	25, 25	500	Stainless steel
65-5- FECP -YZ -XXX	400	4	800	100:1	DN200	25, 25	500	Stainless steel
65-5- FECR -YZ -XXX	400	4	800	100:1	DN250	25, 25	600	Stainless steel
65-5- FFCP -YZ -XXX	600	6	1200	100:1	DN200	25, 25	500	Stainless steel
65-5- FFCR -YZ -XXX	600	6	1200	100:1	DN250	25, 25	600	Stainless steel
65-5- FGCR -YZ -XXX	1000	10	2000	100:1	DN250	25, 25	600	Stainless steel
65-5- FGDS -YZ -XXX	1000	10	2000	100:1	DN300	16, 16	500	Stainless steel

XXX - code for final assembly, approvals etc. - determined by Kamstrup.

Table 4. Type numbers of separate ULTRAFLOW® 54. The meter factor can be programmed according to the application.

### Ordering details of separate ULTRAFLOW® 54

Type number composition of separate ULTRAFLOW® 54

4.2.1

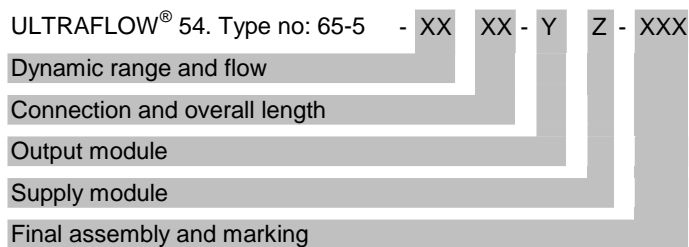

In addition to the basic variants listed in *Table 4*, you must select output module (Y), supply module (Z) as well as meter factor programming (CC) and pulse duration (E).

### Type numbers of output and supply modules

4.2.2 Type number overview of output modules (Y) and supply modules (Z) for separate ULTRAFLOW® 54.

Y	Output module	Corresponding supply module
1	Galvanically coupled module	0 (powered by MULTICAL®)
2	Galvanically separated module	0, 7, 8
3	Galvanically separated module, low power	0, 2, 7, 8

Z	Supply module	Corresponding output module
0	No supply	1, 2, 3
2	Battery, D-cell	3
7	230 VAC supply module	2, 3
8	24 VAC supply module	2, 3

Table 5. Output modules (Y) and supply modules (Z).

The variant with galvanically coupled output module (Y=1) is solely for use together with MULTICAL®.

The variant with galvanically separated output module (Y=2 or 3) is used in the following situations:

- 1) If a cable length of more than 10 m is required between MULTICAL® and ULTRAFLOW®.
- 2) For flow sensor no. 2 in connection with MULTICAL®. If two flow sensors are used together with MULTICAL®, and an equipotential connection between the two flow sensors cannot be carried out, one (typically V2) should be galvanically separated.

For further information see *paragraph 6.13.2 Calculator with two flow sensors*.

- 3) If ULTRAFLOW® is connected to other equipment/foreign calculators, ULTRAFLOW® must be galvanically separated.
- 4) In cases where the electronic signal between ULTRAFLOW® and MULTICAL® is disturbed, galvanic separation may in some cases remedy the problem.

For more information on electrical connection, please see *paragraph 6.12 Electrical connections to MULTICAL®*.

⚠ Flow info cannot be read, if output module with galvanic separation is used.

Programming options of meter factor and pulse durations

Overview of programming options as to meter factors (CC) and pulse durations (E) for separate ULTRAFLOW®

4.2.3

q <sub>p</sub> [m³/h]	Meter factor			Pulse duration				
	[p/l]	[l/p]	CC	[ms] (E=1)	[ms] (E=4)	[ms] (E=5)	[ms] (E=6)	
<b>150</b>	<b>1</b>		<b>33</b>	<b>3.9</b>	-	-	-	<b>Default</b>
150		10	34	-	20	-	-	
150		25	64	-	20	-	-	
150		100	35	-	20	50	100	
150		250	65	-	20	50	100	
150		1000	36	-	20	50	100	
150		2500	66	-	20	50	100	
<b>250</b>	<b>0.6</b>		<b>43</b>	<b>3.9</b>	-	-	-	<b>Default</b>
250		10	34	-	20	-	-	
250		25	64	-	20	-	-	
250		100	35	-	20	50	100	
250		250	65	-	20	50	100	
250		1000	36	-	20	50	100	
250		2500	66	-	20	50	100	
<b>400</b>	<b>0.4</b>		<b>63</b>	<b>3.9</b>	-	-	-	<b>Default</b>
400		100	35	-	20	50	-	
400		250	65	-	20	50	100	
400		1000	36	-	20	50	100	
400		2500	66	-	20	50	100	
<b>600</b>	<b>0.25</b>		<b>14</b>	<b>3.9</b>	-	-	-	<b>Default</b>
600		100	35	-	20	50	-	
600		250	65	-	20	50	-	
600		1000	36	-	20	50	100	
600		2500	66	-	20	50	100	
<b>1000</b>	<b>0.15</b>		<b>24</b>	<b>3.9</b>	-	-	-	<b>Default</b>
1000	(0.25)	4	14	3.9	-	-	-	*)
1000		100	35	-	20	50	-	
1000		250	65	-	20	50	-	
1000		1000	36	-	20	50	100	
1000		2500	66	-	20	50	100	

\*) Spare part for ULTRAFLOW® type 65-S/R/T. Configured 65-5-FGCR. No flow info.

Table 6. Programming options as to meter factor (CC) and pulse durations (E) for ULTRAFLOW® 54 DN150-300.

Based on a q<sub>p</sub> value a meter factor in Table 6 is chosen. The valid possible pulse durations are listed on the same line as the chosen meter factor.

Example: For ULTRAFLOW® 54 q<sub>p</sub> 400 m³/h a meter factor of 100 liter/pulse (CC=35) is required. Based on this meter factor one of the pulse durations, 20 milliseconds (E4) or 50 milliseconds (E5), is selected.

Default values in Table 6 are programming values for ULTRAFLOW® 54 when connected to a Kamstrup MULTICAL® calculator.

### 4.3 Accessories

Please note that not all article numbers can be directly ordered. Some articles must be ordered via Kamstrup service department ([service@kamstrup.com](mailto:service@kamstrup.com)).

Article number	Description	Note
65-000-000-2000	D-cell lithium battery with two-pole connector	Accessory
3026-477 <sup>1)</sup>	Fitting for D-cell battery	Enclosed if battery supply or "No supply" is selected
1650-157 <sup>1)</sup>	Plug for cable screw connection	Enclosed if battery supply or "No supply" is selected

<sup>1)</sup> Obligatory when changing from mains supply module to battery supply.

Article number	Description	Note
65-000-000-7000 <sup>1)</sup>	230 VAC supply module	Accessory
65-000-000-8000 <sup>1)</sup>	24 VAC supply module	Accessory
5000-290	Cable between supply module and output module	Enclosed if supply module is selected
5000-286	24/230 VAC power cable	Optional

<sup>1)</sup> Including 5000-290.

Article number	Description	Note
66-99-011	Output module (Y=1), galvanically coupled	Accessory
66-99-012	Output module (Y=2), galvanically separated	Accessory
66-99-013	Output module (Y=3), galvanically separated, "Low power"	Accessory

Article number	Description	Note
5000-333	2.5 m silicone cable (3-wire)	Default for ULTRAFLOW® when ordered with MULTICAL®  Optional for separate ULTRAFLOW®
5000-259	5 m silicone cable (3-wire)	Optional
5000-270	10 m silicone cable (3-wire)	Optional
3026-478	Mounting fitting for electronics box	Enclosed (mounted)
3026-207.A	Wall bracket including mounting kit	Accessory
6561-332	Short bracket	Accessory
3026-507	Long bracket	Enclosed
1051-006	Collar band for long bracket	Enclosed
1150-140	Gasket, DN150 PN25 (1 pc)	Enclosed (2 pcs.)
1150-139	Gasket, DN200 PN25 (1 pc)	Enclosed (2 pcs.)
1150-141	Gasket, DN250 PN25 (1 pc)	Enclosed (2 pcs.)
1150-164	Gasket, DN300 PN16 (1 pc)	Enclosed (2 pcs.)

4.3.1

**Cables**

ULTRAFLOW® 54 DN150-300, when ordered with MULTICAL®, is supplied with 2.5 m signal cable, optionally 5 or 10 m. The cable is mounted in the ULTRAFLOW® 54 electronics box and in MULTICAL® 603. When ULTRAFLOW® 54 is ordered with MULTICAL® 803, the calculator is supplied separately. Hence the cable is only mounted in the ULTRAFLOW® 54 electronics box.

4.3.2 ULTRAFLOW® 54 DN150-300, when ordered as a separate flow sensor, is optionally available with signal cable in lengths of 2.5, 5 or 10 m. The cable is mounted in the flow sensor’s electronics box.

If 24/230 VAC supply module is selected, the sensor is optionally available with power supply cable. The cable is mounted in the flow sensor’s electronics box from the factory.

**Cable Extender Box**

Cable Extender Box (Type 6699-036) enables a signal cable length of up to 30 m between ULTRAFLOW® and MULTICAL®. The equipment supports flow-info, but not galvanic separation (for more information see *paragraph 4.2.2*). Cable Extender Box (Type 6699-036) must be ordered separately.

Kamstrup offers signal cables in lengths of 2.5 m (Type 5000-333), 5 m (Type 5000-259) and 10 m (Type 5000-270), which can be ordered separately. In combination with the signal cables, which are typically delivered with ULTRAFLOW®, different total lengths of up to 20 m between ULTRAFLOW® and MULTICAL® can be realized. With signal cables of varying lengths but of the same quality as Kamstrup’s signal cables, it is possible to find individual solutions for cable extension up to 30 m between ULTRAFLOW® and MULTICAL®. For electrical connections, see *paragraph 6.12.5*.

## 5 Dimension sketches

### 5.1 ULTRAFLOW® 54 DN150-300

All measurements are in mm, unless otherwise stated.

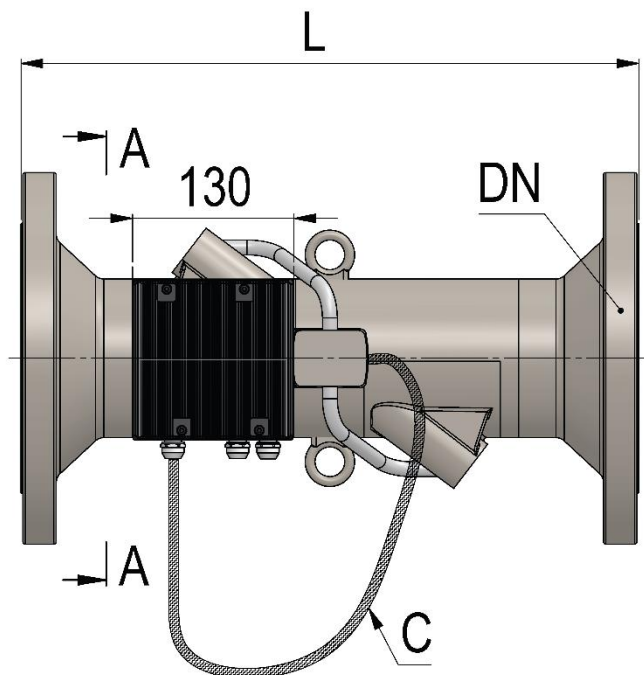

Figure 1. Dimension sketch of ULTRAFLOW® 54 DN150-300 (side view).

Nom. diameter	PN [bar]	Nom. Flow $q_p$ [m <sup>3</sup> /h]	L	D	k	Bolts			B1	E	Steel tube length C	Approx. weight [kg]
						Quantity	Thread	d <sub>2</sub>				
DN150	25	150 & 250	500	300	250	8	M24	26	119	282	650	37
DN150	25	400	500	300	250	8	M24	26	140	303	625	36
DN200	25	400 & 600	500	360	310	12	M24	26	166	329	570	49
DN250	25	400 & 600	600	425	370	12	M27	30	166	329	570	79
DN250	25	1000	600	425	370	12	M27	30	194	357	500	75
DN300	16	1000	500	460	410	12	M24	26	194	357	500	76

Flange facing type B, raised face according to EN 1092-1

Table 7. Dimensions and weight of ULTRAFLOW® 54 DN150-300.

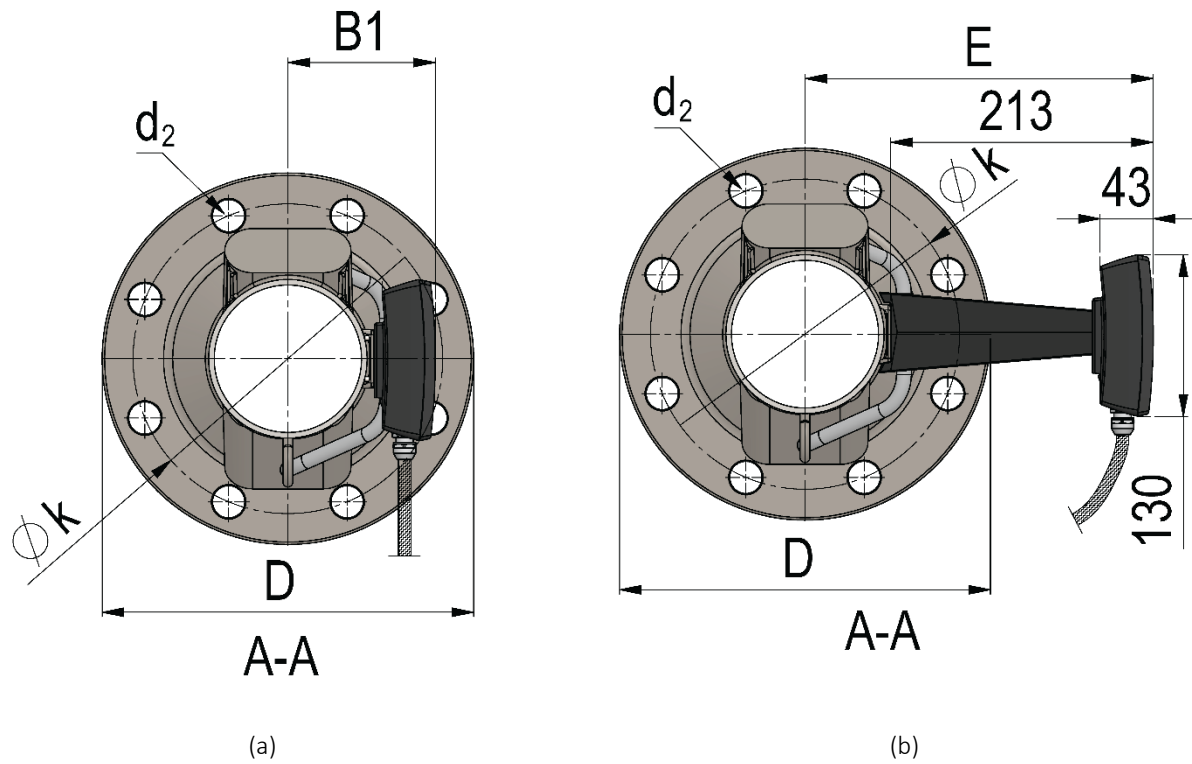

Figure 2. Dimension sketch of ULTRAFLOW® 54 DN150-300 (axial view).  
 Electronics box mounted on mounting fitting 3026-207 (a) or long bracket 3026-507 (b).

## 5.2 Cable Extender Box

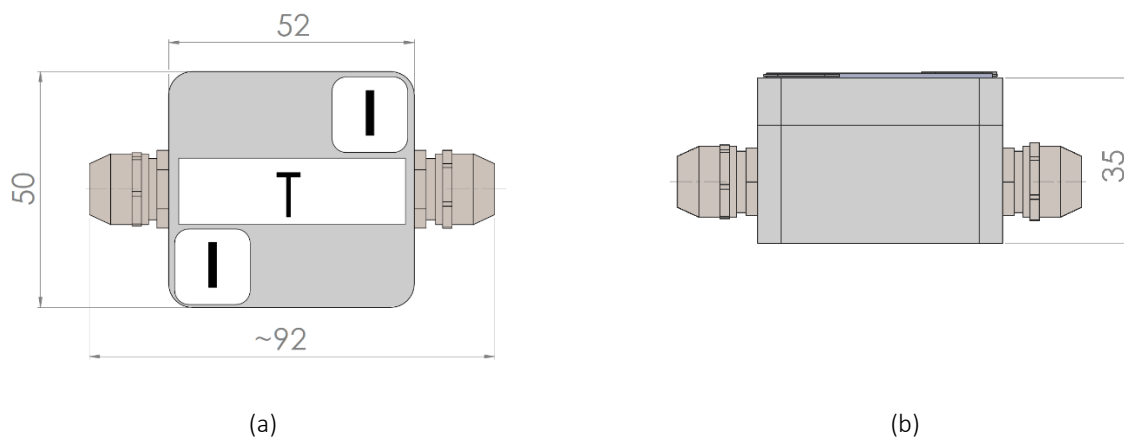

Figure 3. Cable Extender Box seen from the front (a) and from the side (b).

## 6 Installation



Please read this chapter carefully before installing the energy meter. In case of incorrect mounting, Kamstrup's guarantee obligations no longer apply.

### 6.1 Guidelines for dimensioning and operating conditions

#### Introduction

General recommendations for heat and cooling meter installation can be found in EN 1434-6:2015, "Heat meters – Part 6: Installation, commissioning operational monitoring and maintenance" and CEN TR 13582, "Heat meter installation. Instructions in selection, installation and use of heat meters". Due to copyrights, Kamstrup cannot provide you directly with these documents. To acquire CEN TR 13582 (and other EN standards), please refer, for example, to the Danish Standard organization's web shop <https://webshop.ds.dk/en-gb/frontpage?CurrencyCode=EUR>. Alternatively, you can find your national standardization organization here <https://www.iso.org/members.html>.

Consider the following general risks and advice:



By connecting to 230 VAC supply, there is a risk of electrical shock.

When working on the flow sensor in the installation, there is a risk of outflow of (hot) water under pressure.

At a media temperature higher than 60 °C, the flow sensor should be shielded from unintended contact.

New fiber gaskets of the original quality must be used.

ULTRAFLOW® 54 may be lifted in the lifting rings only.



Only use clean water on a damp cloth to clean the meter.

Prior to installation of the flow sensor, the system should be flushed.

Correct flow sensor position (inlet or outlet) appears from the front label or the display of MULTICAL®. The flow direction is indicated by an arrow on the flow sensor. See e. g. *Figure 53*.

When the installation has been completed, water flow can be turned on. Carry out an operational check of the complete thermal energy meter after installing the meter and before leaving the installation site.

## Dimensioning

Consider, among others, the following aspects when dimensioning the meter:

**Pipe dimension:** Note that the flow sensor size shall fit the pipe dimension of the installation. However, one dimension up or down in flow sensor size is acceptable. This means that for a pipe dimension of, for example, DN200 in the installation, a flow sensor size of DN 200 is optimum, but DN150 and DN250 are also acceptable. See also Kamstrup doc. nr. FILE100001074\_EN\_(5811-6554\_GB).

### 6.1.2

**Flow:** The maximum design flow in the system must NOT exceed the nominal flow  $q_p$  of the flow sensor. For further explanation, see 6.1.4 *Operating pressure*.

**Static pressure:** The static pressure at the flow sensor outlet must at all times be above the minimum requirement and in general below the maximum allowable pressure. For further details, see 6.1.4 *Operating pressure*.

**Meter factor:** The meter factor of ULTRAFLOW® and MULTICAL® must be identical (see type label/display). For further details about available meter factors of ULTRAFLOW®, see *Table 1*.

## Operating conditions

The meter must be suitable for the foreseeable operating conditions in the installation:

### 6.1.3

**Pressure stage:** PN16, PS16 or PN25, PS25, see marking. The marking of the flow sensor also covers accessories included such as gaskets.

**Medium temperature <sup>1)</sup>:** 2...150 °C or narrower range, see marking.

<sup>1)</sup> At medium temperature higher than 60 °C the flow sensor should be shielded against unintentional contact. At medium temperatures above 90 °C or below the ambient temperature, calculator and the electronics box must not be mounted on the flow sensor. Instead wall-mounting of calculator and electronics box (minimum distance to flow sensor of minimum 170 mm) or mounting of the electronics box via the enclosed long bracket are recommended. See e. g. *Figure 9*, *Figure 10* and *Figure 11*.

**Mechanical environment:** **MID M1** – applies to instruments used in locations with vibration and shocks of low significance, e.g. for instruments fastened to light supporting structures subject to negligible vibrations and shocks transmitted from local blasting or pile-driving activities, slamming doors, etc.– **and M2** – applies to instruments used in locations with significant or high levels of vibration and shock, e.g. transmitted from machines and passing vehicles in the vicinity or adjacent to heavy machines, conveyor belts, etc..

**Electromagnetic environment:** **MID E1** – applies to instruments used in locations with electromagnetic disturbances corresponding to those likely to be found in residential, commercial and light industrial buildings. – **and E2** – applies to instruments used in locations with electromagnetic disturbances corresponding to those likely to be found in other industrial buildings. **EN 1434 class C** (high electrical and electromagnetic conditions).  
**⚠ The meter's cables must be drawn at min. 25 cm distance from other installations.**

**Ambient conditions:** The ambient temperature must be within 5...55 °C. Installation must be in closed locations (indoors).

**Static pressure:** To minimize the risk of measuring errors as a result of cavitation or air in the water it is recommended to keep a sufficient static pressure at the flow sensor outlet

depending on size and flow according to *Table 8*. This applies to temperatures up to approx. 80 °C. It is particularly recommended to follow this advice during meter calibration. In absence of cavitation, the flow sensor is typically functioning at lower operating pressure. See also *6.1.4 Operating pressure*.

**Pressure loss:** Consider the pressure loss of the installed flow sensor for dimensioning of pumps in your installation. For further details, see *6.1.5 Pressure loss*.

**Protection class <sup>2)</sup> /**

<b>Climatic conditions:</b>	Flow sensor:	IP67 <sup>3)</sup>
<sup>2)</sup> acc. to EN 60529	Cable Extender Box:	IP65

<sup>3)</sup> IP classification is limited by the electronics box, which can be installed with a suitable distance to the flow sensor, if necessary e. g. due to permanent condensation.

<sup>2)</sup> IP6X means that persons handling the instrument are protected against access to hazardous parts even when dealing with a thin wire of 1.0 mm diameter. In addition, the inside of the instrument is protected against ingress of dust (**dust-tight**).

<sup>2)</sup> IPX5 means that that the instrument is **protected against water jets** coming **from any directions** to the enclosure.

For the Cable Extender Box, this means that the IP class is higher than required by EN 1434 for other enclosures, which are not to be installed in pipe work. Note that it is the responsibility of the installer to ensure proper mounting of the cable screw connections as otherwise the IP classification is not valid. Flow sensor and Cable extender box are not protected against periodically or permanently wet conditions and must not be submerged.

<sup>2)</sup> IPX7 means that ingress of water in quantities causing harmful effects are not possible even when the enclosure of the instrument is **temporarily immersed** in water.

For the electronics box of ULTRAFLOW® 54, this means that it is well protected and durable in periodically wet conditions. It withstands being submerged for max 30 min, but only in case of proper mounting of the cable screw connections. It is the responsibility of the installer to ensure proper mounting of the cable screw connections as otherwise IP classification is not valid (see *6.12.4.4 Cable screw connections*). When the electronics box is wall-mounted or mounted via the enclosed long bracket with a distance to the flow sensors, ULTRAFLOW® 54 (i.e. exclusively its electronics box) is even well protected and durable in permanently wet conditions.

💡 When installing a thermal energy meter, the installation recommendations of all three sub-assemblies, i.e. flow sensor, temperature sensor set and calculator, must be considered. This applies in particular when a calculator is mounted directly on a flow sensor.

**Operating pressure**

To minimize the risk of measuring errors as a result of cavitation or air in the water, it is recommended to keep a sufficient static pressure at the flow sensor outlet according to *Table 8*. This applies to temperatures up to approx. 80 °C. It is particularly recommended to follow this advice during meter calibration. In absence of cavitation, the flow sensor is typically functioning at lower operating pressure.

6.1.4

Nominal flow $q_p$ [m³/h]	Recommended min. static pressure [bar]	Max. flow $q_s$ [m³/h]	Recommended min. static pressure [bar]
150	1	300	2
250	1.5	500	2.5
400 (DN150)	1.5	800	2.5
400	1	800	2
600	1.5	1200	2.5
1000	1.5	2000	2.5

*Table 8. Recommended minimum static pressure at flow sensor outlet.*

It is not necessarily cavitation in the sensor itself, but also bubbles from cavitating pumps and regulating valves mounted before the sensor. It can take some time until such bubbles have been dissolved in the water. Furthermore, water can include air which is dissolved in the water. The amount of air which can be dissolved in water depends on pressure and temperature. This means that air bubbles can be formed due to a decrease in pressure, e.g. caused by a velocity rise in a pipe contraction or in the sensor. The risk of these factors affecting accuracy is reduced by maintaining a suitable pressure in the system.

In relation to the recommended static pressure, the steam pressure at the current temperature must also be considered. The recommended static pressure applies to temperatures up to approx. 80 °C.

**Steam pressure**

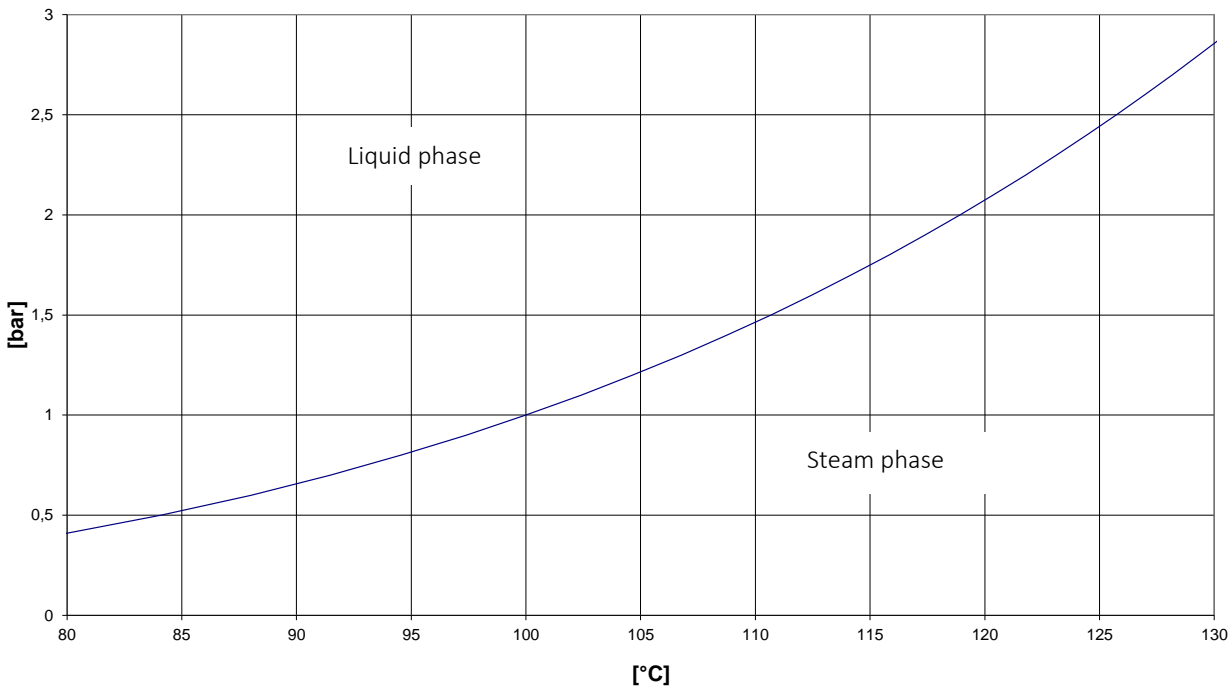

*Figure 4. Steam pressure of water. At low temperature and high pressure, water is in the liquid phase. At high temperature and low pressure, water is in the steam phase. The blue curve characterizes the equilibrium of the liquid and steam phases.*

The steam pressure is the pressure where steam and liquid are in equilibrium at the current temperature (boiling point at a given pressure). At low temperature and high pressure, water is in the liquid phase. At high temperature and low pressure, water is in the steam phase. The blue curve (the steam pressure curve) in *Figure 4* thus characterizes the equilibrium of the liquid and steam phases. This means that the static pressure in water must be increased at a given temperature to avoid the steam phase that is shown in the lower right corner of the graph in *Figure 4*.

Furthermore, it must be taken into account that the above static pressure is lower after a contraction than before (e.g. at cones). This means that the static pressure – when measured elsewhere in the installation– might be different from the pressure at the flow sensor outlet.

This can be explained by combining Bernoulli’s equation and the continuity equation. Based on Bernoulli's equation, the total pressure of the flow will be the same for any cross section. It can be reduced to:

$$p_{stat.} + p_{dynam.} = p_{stat.} + \frac{1}{2}\rho v^2 = constant \quad (\text{Bernoulli's equation})$$

$p_{stat.}$  is the static pressure.  $[Pa = \frac{N}{m^2} = \frac{kg}{s^2 \cdot m}]; 1 bar = 10^5 \frac{N}{m^2}$

$p_{dynam.}$  is the dynamic pressure.  $[Pa = \frac{N}{m^2} = \frac{kg}{s^2 \cdot m}]; 1 bar = 10^5 \frac{N}{m^2}$

$\rho$  is the water density.  $[\frac{kg}{m^3}]$

$v$  is the water flow rate.  $[\frac{m}{s}]$

The continuity equation determines that the product of pipe cross sectional area  $A$  and average flow velocity  $v$ , which corresponds to the volume flow rate passing through, is constant for an incompressible fluid like e.g. water. Therefore, the flow velocity is increased in a contraction and the static pressure decreases.

$$q = A_1 \cdot v_1 = A_2 \cdot v_2 = \dots = A_i \cdot v_i = constant \quad (\text{Continuity equation})$$

When dimensioning a flow sensor, you must take the above into consideration, especially if the sensor is used within the scope of EN 1434 between  $q_p$  and  $q_s$ , and in case of major pipe contractions. In general, the maximum design flow in the system must NOT exceed the nominal flow  $q_p$  of the flow sensor.

**Pressure loss**

Pressure loss in a flow sensor is stated as max. pressure loss at  $q_p$ . According to EN 1434 max. pressure loss must not exceed 0.25 bar unless the energy meter includes a flow controller or functions as pressure reducing equipment.

The pressure loss in a meter increases with the square of the flow and is usually stated as a direct proportionality between the flow and the square root of the pressure loss:

$$\Delta p = \frac{1}{k_v^2} q^2 \Leftrightarrow q = k_v \times \sqrt{\Delta p}$$

where:

$$q = \text{volume flow rate } [q] = \frac{m^3}{h}$$

$$k_v = \text{volume flow rate at 1 bar pressure loss } [k_v] = \frac{m^3}{h \cdot \sqrt{bar}}$$

$$\Delta p = \text{pressure loss } [\Delta p] = bar; 1 bar = 10^5 Pa$$

Graph	Nom. flow $q_p$ [m³/h]	Type number <sup>1)</sup>	Nom. diameter [mm]	Length [mm]	$\Delta p@q_p$ [bar]	$k_v$	Q@0,25 bar [m³/h]
A	150	65-5- FCCN -XXX	DN150	500	0.02	1060	530
	250	65-5- FDCN -XXX	DN150	500	0.055		
B	400	65-5- FECN -XXX	DN150	500	0.04	2000	1000
C	400	65-5- FECP -XXX	DN200	500	0.01	4040	2020
		65-5- FECR -XXX	DN250	600			
	600	65-5- FFCP -XXX	DN200	500	0.022		
		65-5- FFCR -XXX	DN250	600			
D	1000	65-5- FGCR -XXX	DN250	600	0.015	8160	4080
		65-5- FGDS -XXX	DN300	500			

<sup>1)</sup> XXX - code for final assembly, approvals etc. - determined by Kamstrup. A few variants may not be available in national approvals.

Table 9. Pressure loss table.

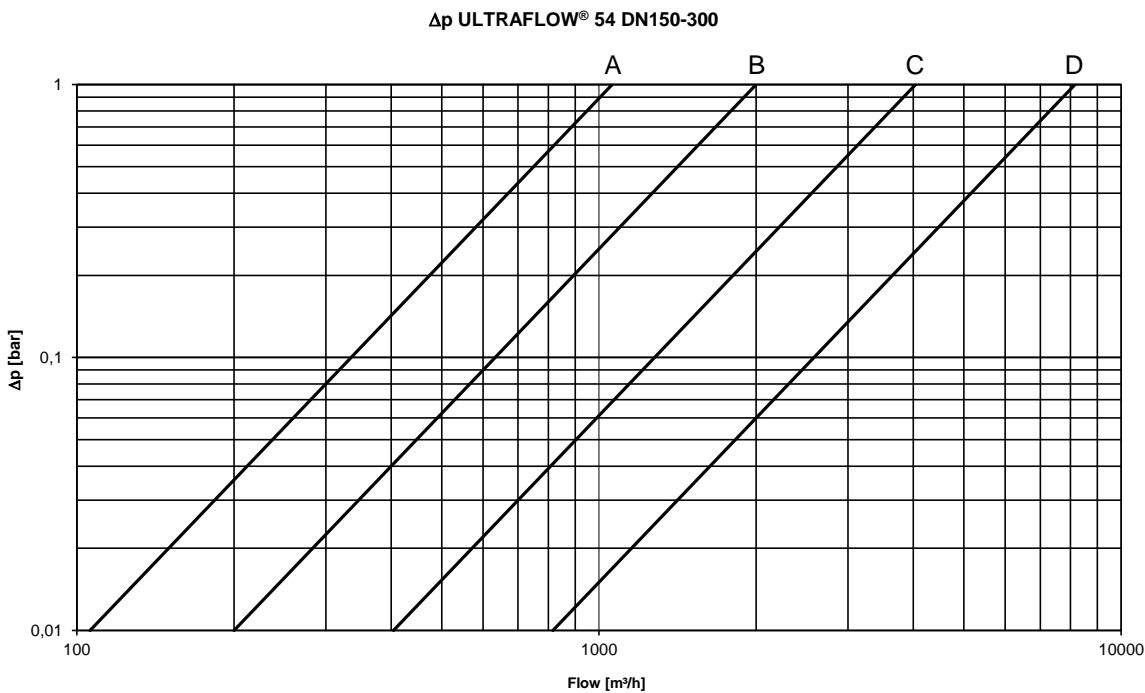

Figure 5. Pressure loss diagram.



## 6.2 Connections and cable length

Direct connection of ULTRAFLOW® is only permitted to Kamstrup MULTICAL® calculators on terminals 11-9-10, as shown in 6.12.1 *ULTRAFLOW® 54 and MULTICAL®, galvanically coupled*. Connection to other calculator types requires the use of a galvanically separated output modules to obtain galvanic separation between ULTRAFLOW® and the calculator (6.12.2 *ULTRAFLOW® 54 and MULTICAL®, galvanically separated*).

⚡ Check that the meter factor is the same on the flow sensor and the calculator or program the flow sensor appropriately, if this is not the case.

ULTRAFLOW® 54 can be provided with a signal cable length of 2.5 m, 5 m or 10 m. If necessary in your installation, the signal cable length can be shortened. In these cases, we recommend to use cable end sleeves and to crimp them. For a cable length of more than 10 m between ULTRAFLOW® and MULTICAL®, see *Table 12*.

## 6.3 Flow sensor position (Inlet/Outlet)

Correct flow sensor position (inlet or outlet) appears from the front label or display of MULTICAL® where  indicates the position in inlet and  indicates the position in outlet. When ULTRAFLOW® is connected to another calculator, ULTRAFLOW® can be used for both inlet and outlet. Crucial is the coding of the calculator. The flow direction of ULTRAFLOW® is indicated by arrows on the flow sensor.

## 6.4 Insulation

Insulation of pipes utilized for transmitting thermal energy conveying liquids is in general always recommended, because the insulation reduces losses of valuable heat energy or avoids heating of the medium, which is utilized for cooling. Thus, insulation optimizes the supply of thermal energy with thermal energy conveying liquids. To further optimize the supply, insulation of flow and temperature sensors, which are both in direct contact with the thermal energy conveying liquid, must also be addressed. As the calculator of a heat/cooling meter is not in direct contact with the thermal energy conveying liquid, insulation of the calculator as such is not applicable. However, due to the possibility of mounting the calculator directly on the flow sensor, installation recommendations for the calculator must be considered depending on the temperature of the medium and the environment.

Insulation has the effect, that all parts under the insulation might reach temperatures up to the temperature of the thermal energy conveying liquid as thermal balance to the environment is prohibited. This might be critical to some components, in particular to sensitive electronics. Predominantly in cooling installations, humidity from the warm environment will condense on comparatively colder pipes. This is why they are often permanently wet. Insulation therefore requires temperature stability of the insulated parts within the approved range of the medium temperature as well as waterproof encapsulation of sensitive electronic components in cooling installations in warm and humid environments. Finally, note that local rules concerning insulation of pipes might apply.

*Table 10* gives a general overview of the insulation recommendations for Kamstrup flow and temperature sensors. *Figure 16* and *Figure 17* illustrate specifically the insulation of ULTRAFLOW® 54 DN150-300.





Flow sensor	 Cooling	 Heat $T_{\text{medium}} < 110\text{ °C}$ 	 Heat $T_{\text{medium}} > 110\text{ °C}$ 
MULTICAL® 303	Yes		Yes (except for the plastic case)
MULTICAL® 403			
ULTRAFLOW® 44 DN15-125			
ULTRAFLOW® 54 DN15-125	N/A	Yes (except for the plastic case)	
ULTRAFLOW® 54 DN150-300	Yes (except for the plastic case)		
TemperatureSensor 63 & 83	Yes		

Table 10. Overview of insulation recommendations for different flow sensors and for TemperatureSensor 63 & 83.

### 6.5 Inlet prerequisites

ULTRAFLOW® 54 DN150-300 requires neither straight inlet nor straight outlet to meet the Measuring Instruments Directive (MID) 2014/32/EU, OIML R75:2002 and EN 1434<sup>1</sup>. A straight inlet section is only necessary in case of heavy flow disturbances before the meter. It is recommended to follow the guidelines in *CEN TR 13582, Heat meter installation. Instructions in selection, installation and use of heat meters*. See also Kamstrup doc. no. FILE100001058\_EN\_(5811-6595\_GB).

Optimal position can be obtained if you take the below installation recommendations into consideration:

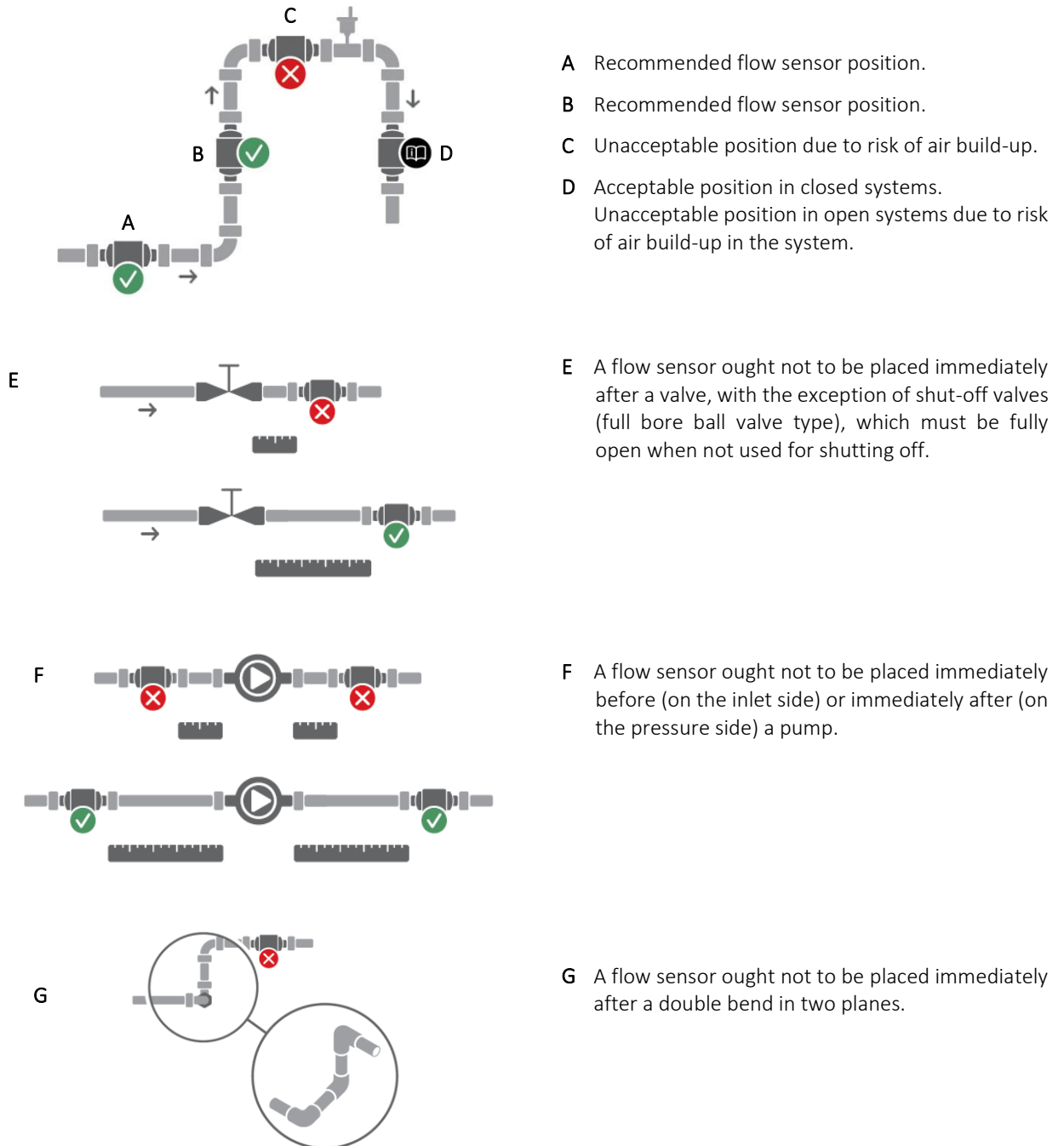

Figure 6. General installation recommendations for flow sensors.

<sup>1</sup> Types FCCN, FDCN, FECR, FFCR, FGDS acc. to EN 1434:2007/AC2007, EN 1434:2015+A1:2018 and EN 1434:2022. Types FECN, FECP, FFCE, FGCR acc. to EN 1434:2007/AC2007 and EN 1434:2015+A1:2018.

## 6.6 Orientation of ULTRAFLOW® 54

### General recommendations

6.6.1

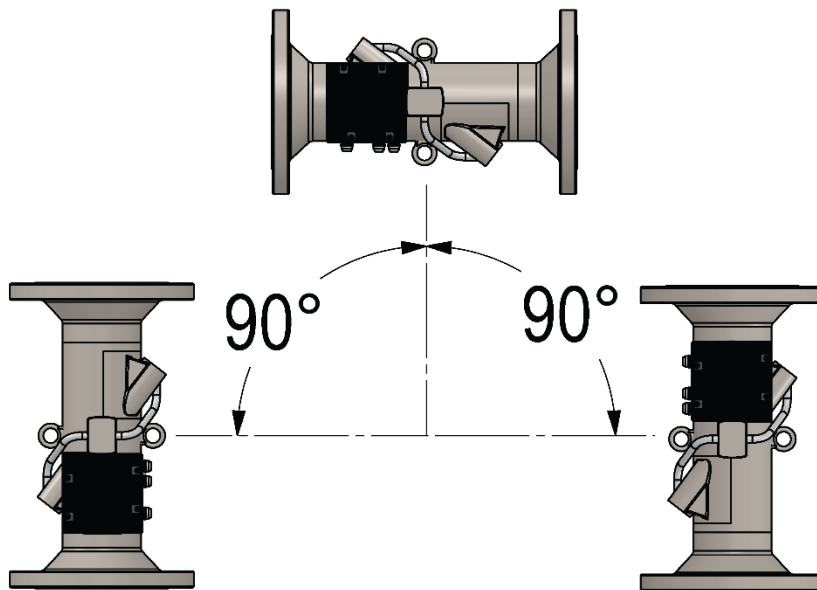

Figure 7

ULTRAFLOW® can be installed horizontally, vertically, or at an angle.

ULTRAFLOW® 54 is normally installed horizontally, with the lifting rings oriented vertically. The ultrasound paths in the flow sensor tube will thus be vertical, which is optimal in connection with possible stratification of the medium.

6.6.2

### Recommendations for heat, cooling and bi-functional heat/cooling installations

The general recommendations apply for heat, cooling and bi-functional heat/cooling installations. However, positioning of the electronics box is depending on the medium temperature. See 6.7 *Mounting of ULTRAFLOW® 54 electronics box* for further information.

## 6.7 Mounting of ULTRAFLOW® 54 electronics box

At **medium temperature below 90 °C and at medium temperature above ambient temperature** the electronics box can be mounted directly on the flow sensor housing via the factory mounted fitting.

If the flow sensor is vertically mounted, the cable screw connections of the electronics box will be horizontally oriented. This is permitted. If the cable screw connections should preferably point downwards, the electronics box can be mounted via the enclosed bracket, which moves the box approx. 170 mm away from the flow sensor housing. Alternatively, a shorter bracket, which only moves the box approx. 45 mm away from the flow sensor housing, can be used. The short bracket must be ordered separately (6561-332).



Figure 8

At **medium temperature above 90 °C** the temperature is too high for the electronics box to be mounted directly on the flow sensor housing.

Therefore, the electronics box must be mounted via the enclosed distance piece. The cable screw connections must always point downwards. (See *paragraph 6.7.1*)

Alternatively, the electronics box can be wall mounted as long as the distance to flow sensor housing and pipe installation is minimum 170 mm.



Figure 9

It can also be an advantage to use the enclosed bracket if the flow sensor housing is insulated and the electronics box must be removed from the insulation.

If the required position of the electronics box differs from standard position, the bracket can be mounted with the enclosed collar band around the flow sensor housing. However, please note that the cable screw connections must always point downwards. (See *paragraph 6.7.1*)

At **medium temperature below ambient temperature** (typically in cooling installations) it is important to take action to avoid condensation in the electronics box.

Therefore, the electronics box must be mounted via the enclosed bracket.

The cable screw connections must always point downwards. (See *paragraph 6.7.1*)

If ULTRAFLOW® is insulated, the electronics box must be kept out of the insulation.

Alternatively, the electronics box can be wall mounted as long as the distance to flow sensor housing and pipe installation is minimum 170 mm.

Furthermore, when mounting the electronics box please make sure that the cable screw connections on the box are at a higher level than the cable connection on the flow sensor housing.

By vertical mounting of ULTRAFLOW® 54 in a riser this can be secured by mounting the distance piece by means of the collar band as shown in *Figure 10*.



Figure 10

If ULTRAFLOW® 54 is mounted horizontally, the electronics box can be mounted on the bracket by means of the collar band. The bracket can then be turned upwards until the cable screw connections on the electronics box are in a higher position than the cable connection on the flow sensor housing. See *Figure 11*.

Alternatively, the electronics box can be wall mounted at a suitable distance to the installation (minimum 170 mm).

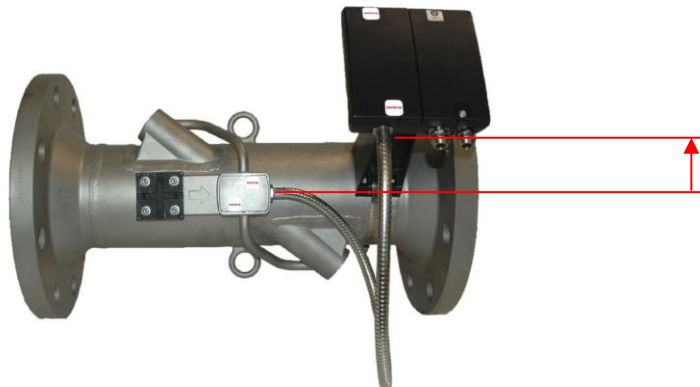

Figure 11

**Orientation of flow sensor electronics box**

6.7.1 Mounting the electronics box, the cable screw connections must always be horizontally or downwards oriented in order to avoid the risk of water and condensation being led into the electronics box via the cables.

This is especially important in humid environments, when ULTRAFLOW® 54 is used as a cooling sensor or if the medium temperature can become lower than the ambient temperature.

Furthermore, steel tube and wires must in general hang freely downwards after the cable connections to form a drip nose for drainage of water and condensation.

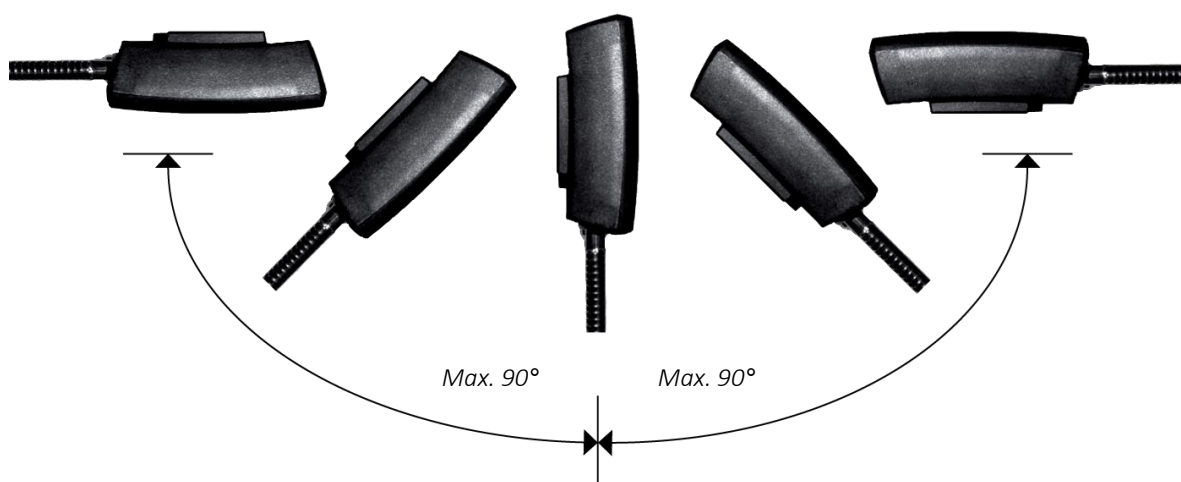

Figure 12

### Wall-mounting of the electronics box

⚠ At medium temperatures above 90 °C and below the ambient temperature, calculator and the electronics box must not be mounted on the flow sensor. Instead, wall-mounting or mounting with the enclosed long bracket is recommended.

Wall mounting of MULTICAL® and the electronics box protects these instruments against overheating in a heat installation and condensing water in a cooling installation.

6.8.1

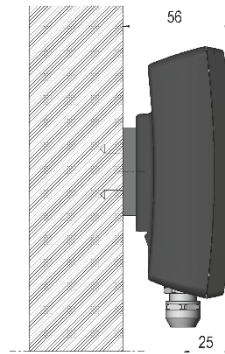

Figure 13. Electronics box of ULTRAFLOW® 54 (DN150-300) mounted on fitting 3026-207.A

## 6.9 Mounting of Cable Extender Box

Cable Extender Box is lightweight and can therefore hang freely as an integrated part of the signal cable from the ULTRAFLOW® flow sensor to the calculator. Alternatively, Cable Extender Box can be wall-mounted. The base part of Cable Extender Box contains 2 holes for this purpose, which are prepared for mounting screws.

## 6.10 Maintenance and service during operation

The flow sensor is verified separately and can, therefore, be separated from the calculator. It is permitted to replace the supply and change the supply type. For battery supply a lithium battery with connector from Kamstrup A/S must be used. Lithium batteries must be correctly handled and disposed of (see Kamstrup document 5510-408, "Lithium batteries - Handling and disposal"). Other repairs require subsequent re-verification in an accredited laboratory.

If ULTRAFLOW® 54 is connected via a galvanically coupled output module, the flow sensor may be connected to a Kamstrup MULTICAL® calculator only.

If other calculator types are connected, ULTRAFLOW® 54 must be fitted with a galvanically separated output module and a power supply of its own.

The steel tube between flow sensor housing and electronics box may not be disassembled.

6.11 Installation examples (mechanical)

Mounting ULTRAFLOW® 54 in lifting ring

ULTRAFLOW® 54 can be mounted hanging from one of the two lifting rings depending on required flow direction. The enclosed bracket can be used to secure optimal position of the electronics box. (See *paragraph 6.7*)

6.11.



← Flow

Figure 14



Flow →

Figure 15

### Insulation of ULTRAFLOW® 54 (DN150-300)

The electronics of ULTRAFLOW® 54 DN150-300 is placed in a separate black electronics box (pos. 1) connected to the flow part (pos. 2) via an approximately 50 cm flexible steel tube (pos. 3).

The flow part (pos. 2) may be insulated. The electronics box (pos. 1) must NOT be insulated. **This applies to both cooling and heat installations.**

If the temperature of the medium is below ambient temperature or above 90 °C or the flow sensor is insulated, the electronics of the flow sensor must be mounted via the enclosed long bracket as shown below (Figure 16) or mounted on the wall (Figure 17). This is to avoid excessive thermal transport from the flow sensor housing causing condensation in the box/excessive heating of the electronics. Alternatively, the electronics box can be wall-mounted at a suitable distance (min. 170 mm) to any cold/hot parts of the installation.

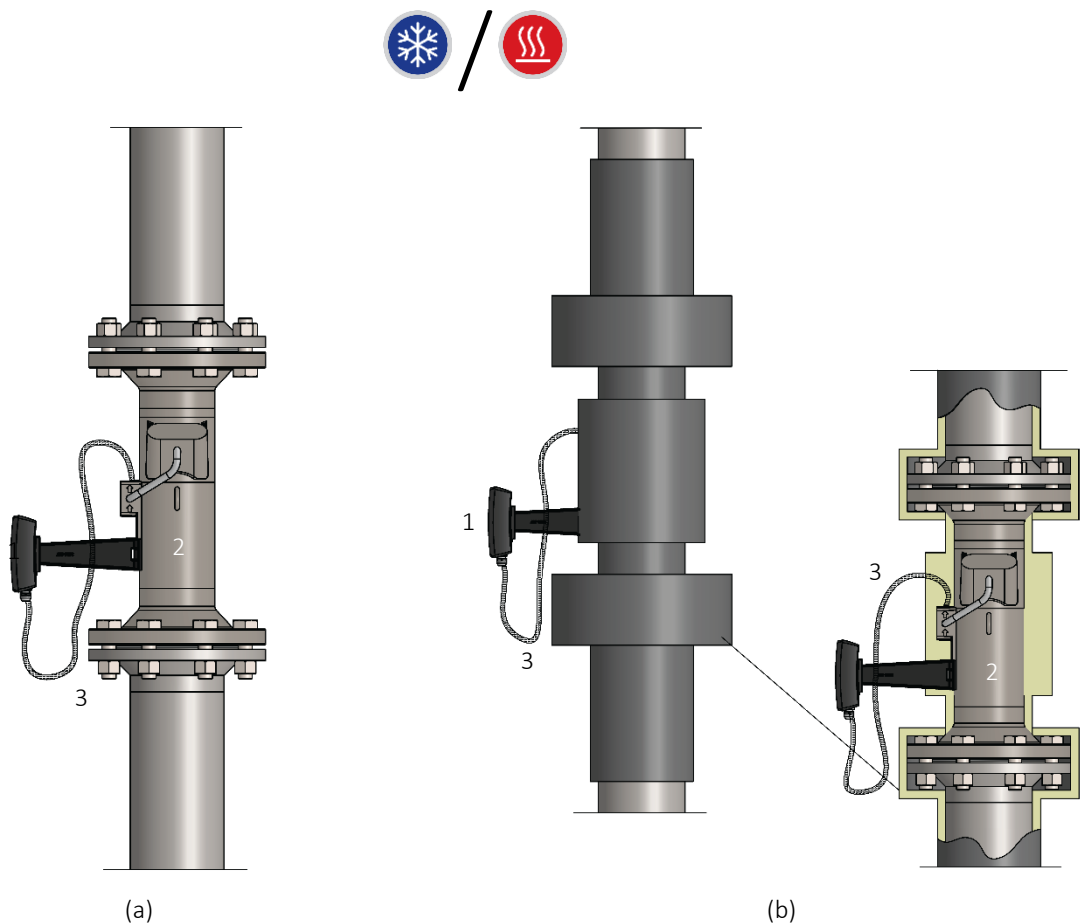

Figure 16. Non-insulated ULTRAFLOW® 54 (DN150-300)  
e. g. at medium temperature below ambient temperature or above 90 °C (a) and  
insulated ULTRAFLOW® 54 (DN150-300) (b). The electronics box  
shall in both cases be mounted via the enclosed long bracket.

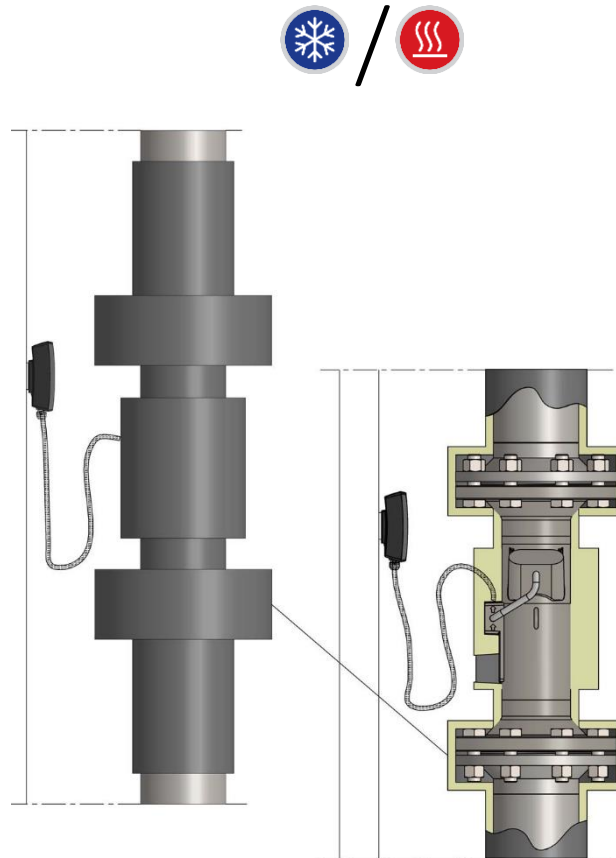

Figure 17. Insulation of ULTRAFLOW® 54 (DN150-300). The electronics box is mounted on the wall.

## 6.12 Electrical connections to MULTICAL®

### ULTRAFLOW® 54 and MULTICAL®, galvanically coupled

If ULTRAFLOW® 54 and MULTICAL® are connected via output module (Y=1), ULTRAFLOW® is galvanically coupled with the MULTICAL® calculator and is powered by this via the three-wire signal cable (cable length up to 10 m).

Battery lifetime in e.g. MULTICAL® 603 is approximately 16 years depending on communication modules in the calculator.

See *paragraph 7.6.1* for electrical data on output module (Y=1).

#### 6.12.1

⚠ It is not permitted to mount a supply module or battery in ULTRAFLOW® 54 with output module (Y=1).

ULTRAFLOW® 54	→	MULTICAL®		
11	→	11	GND	(Blue)
9	→	9	+3,6 V	(Red)
10	→	10		(Yellow)

Table 11

### ULTRAFLOW® 54 and MULTICAL®, galvanically separated

6.12.2 If ULTRAFLOW® 54 and MULTICAL® are connected via output module (Y=2 or 3) ULTRAFLOW® 54 is galvanically separated from MULTICAL®.

See *paragraph 7.6.2* for electrical data on output module (Y=2 and 3).

⚠ Flow info cannot be read.

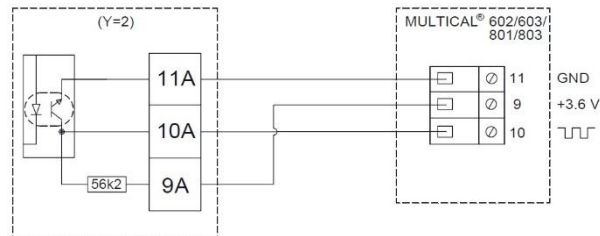

Figure 18. Three-wire connection to MULTICAL® 602/603/801/803 via output module (Y=2). Cable length < 10 m.

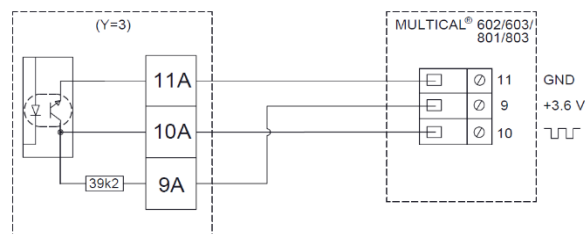

Figure 19. Three-wire connection to MULTICAL® 602/603/801/803 via output module (Y=3). Cable length < 10 m.

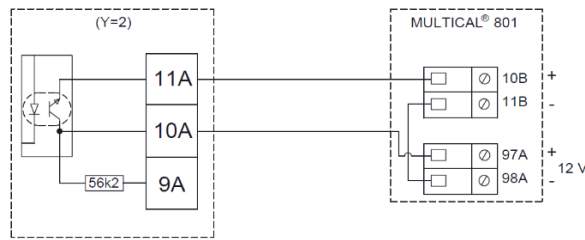

Figure 20. Two-wire connection to MULTICAL® 801 via output module (Y=2). Note the 12 VDC auxiliary supply in MULTICAL® 801. Cable length < 100 m.

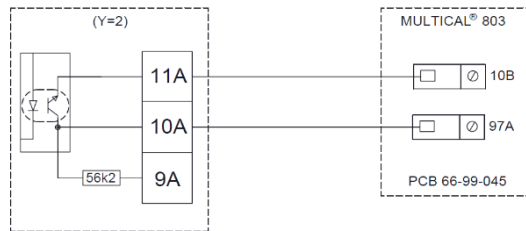

Figure 21. Two-wire connection to MULTICAL® 803 via output module (Y=2). Note the auxiliary supply in MULTICAL® 803 via PCB 66-99-045. Cable length < 100 m.

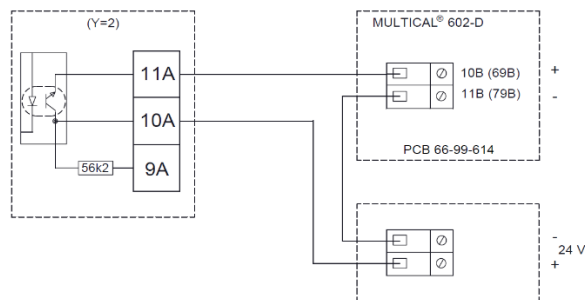

Figure 22. Two-wire connection to MULTICAL® 602-D via output module (Y=2) and external 24 VDC<sup>1)</sup> supply. Cable length < 100 m.

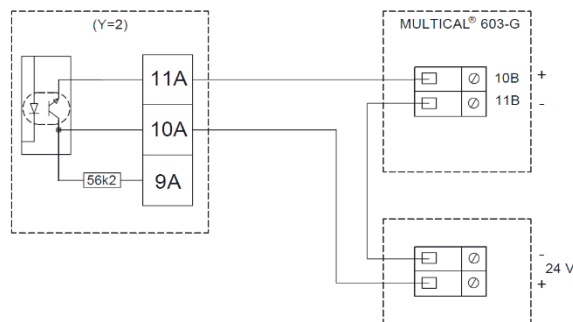

Figure 23. Two-wire connection, MULTICAL® 603-G via output module (Y=2) and external 24 VDC<sup>1)</sup> supply. Cable length < 100 m.

<sup>1)</sup> External 24 VDC supply is not part of the calculator.

Cable length

6.12.3

ULTRAFLOW® 54 DN150-300 output module	MULTICAL® 602/603/801/803	
	2-wire connection	3-wire connection
Y=1	N/A	< 10 m
Y=2	< 100 m *)	< 10 m
Y=3	N/A	< 10 m

\*) MULTICAL® 602 must have sensor connection type D and external 24 VDC supply.  
 MULTICAL® 603 must have sensor connection type G and external 24 VDC supply.  
 MULTICAL® 801 features 12 VDC auxiliary supply.  
 MULTICAL® 803 features auxiliary supply via PCB 66-99-045.

Table 12. Maximum allowable cable length depends on the output module in ULTRAFLOW® 54 DN150-300 and how the MULTICAL® calculator is connected.

If long signal cables are used, installation requires careful consideration. Due to EMC there must be a distance of min. 25 cm between signal cables and all other cables. Recommended cable cross section for the signal cable is 2 x 0.5 mm<sup>2</sup>.

**Connection of power supply**

If ULTRAFLOW® 54 is mounted with a galvanically coupled output module and connected to MULTICAL®, the flow sensor is supplied by the calculator. Therefore, the flow sensor must not be fitted with a supply of its own.

ULTRAFLOW® 54 may be connected to other calculators via the galvanically separated output module only, and the flow sensor must, therefore, be fitted with a supply module or battery.

Supply module and battery are connected to the two-pole connector on the output module.

6.12.4

6.12.4.1 Battery supply

ULTRAFLOW® 54 is fitted with a D-cell lithium battery with connector. The battery plug is connected to the output module.

Optimal battery lifetime is obtained by keeping the battery temperature below 30 °C, e.g. by wall mounting the electronics box.

The voltage of a lithium battery is almost constant throughout the lifetime of the battery (approx. 3.65 V). Therefore, it is not possible to determine the remaining capacity of the battery by measuring the voltage.

The battery cannot and must not be charged and must not be short-circuited.

The battery supply may only be replaced by a corresponding lithium battery with connector from Kamstrup A/S. Used batteries must be handed in for approved destruction, e.g. at Kamstrup A/S. (See Kamstrup document 5510-408, "Lithium batteries - Handling and disposal").

6.12.4.2 Mains supply modules

The mains supply modules are protection class II and are connected to the output module via a small two-wire cable with plugs. The modules are powered via a two-wire mains supply cable (without earth connection) through the cable connector of the electronics box. Use supply cable with an outer diameter of 4.5-10 mm and ensure correct stripping of insulation as well as correct tightening of cable screw connection (see *paragraph 6.12.4.4*).

Max. permitted fuse: 6 A

**230 VAC**

This PCB module is galvanically separated from the mains supply and is suitable for direct 230 VAC mains installation. The module includes a double-chamber safety transformer, which fulfils double-isolation requirements when the cover is mounted on the electronics box. Power consumption is less than 1 VA or 1 W.

National regulations for electric installations must be observed. The 230 VAC module can be connected/disconnected by the district heating station's personnel, whereas the fixed 230 VAC installation to the main electrical panel must be carried out by an authorized electrician.

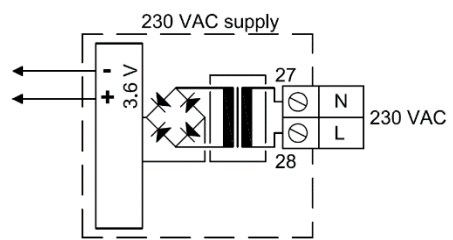

Figure 24. 230 VAC supply module.

**24 VAC**

This PCB module is galvanically separated from the 24 VAC mains supply and is both suitable for industrial installations with joint 24 VAC supply and individual installations, which are supplied by a separate 230/24 VAC safety transformer in the main electrical panel. The module includes a double-chamber safety transformer, which fulfils double-isolation requirements when the cover is mounted on the electronics box. Power consumption is less than 1 VA or 1 W.

National regulations for electric installations must be observed. The 24 VAC module can be connected/disconnected by the district heating station's personnel, whereas the fixed 230/24 VAC installation in the main electrical panel must only be carried out by an authorized electrician.

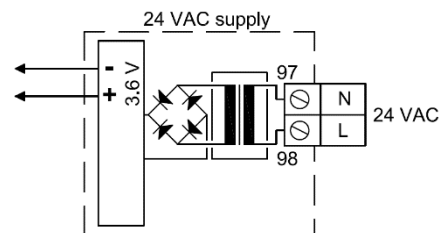

Figure 25. 24 VAC supply module.

⚡ This module cannot be supplied by 24 VDC (direct current).

### 230/24 VAC safety transformer

The 24 VAC module is especially suited for installation together with a 230/24 VAC safety transformer, e.g. type 66-99-403, which can be installed in the main electrical panel before the safety relay. When the transformer is used, the total power consumption of the meter incl. the 230/24 VAC transformer will not exceed 1.7 W.



Figure 26. 230/24 VAC safety transformer.

#### 6.12.4.3 Mains supply cable

ULTRAFLOW® 54 is available with mains supply cable H05 VV-F for either 24 V or 230 V (l=1.5 m):

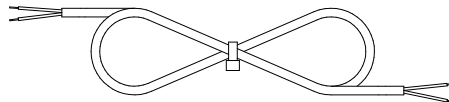

Figure 27. Mains cable (2x0.75 mm<sup>2</sup>), max. 6 A fuse.

“H05 VV-F” is the designation of a strong PVC mantle, which withstands max. 70 °C. Therefore, the mains cable must be installed with sufficient distance to hot pipes etc.

#### 6.12.4.4 Cable screw connections

Cable dimension in connections for mains supply and pulse output: 4.5...10 mm.

Tightening torque: Maximum 4 Nm (cable strain relief minimum 40 N according to EN 61558)

⚠ If ULTRAFLOW® 54 is mounted with a galvanically coupled output module, or if a galvanically separated output module is used in combination with battery supply, the unused cable screw connection must be sealed off, as shown in *Figure 29*.

#### 6.12.4.5 Change of supply unit

The supply unit of ULTRAFLOW® 54 can be changed from mains supply to battery or vice versa as the needs of the supply company change. Thus, it can be an advantage to temporarily change mains supplied meters to battery supplied meters e.g. in case of buildings under construction, where the mains supply can be unstable or is periodically missing.

Please note that the supply type of some ULTRAFLOW® sensors appears from the label. If the original supply type is changed, it will no longer be in accordance with the label.

### Electrical connection of Cable Extender Box

6.12.5 The Cable Extender Box includes transient transorb diodes, making it possible to extend the cable between ULTRAFLOW® and MULTICAL® with up to 30 m in total, while the cable length without the Cable Extender Box can be maximum up to 10 m.

Mount Cable Extender Box to the wall or the like close to ULTRAFLOW®. Connect the 3 wires in the cable from ULTRAFLOW® to one of the two terminals in Cable Extender Box. You can select any of the terminals. Use a 3-wire extension cable with a length of up to 27.5 m with the same wire diameter and of the same quality as the cable from ULTRAFLOW®, and connect the 3 wires to the other terminal in Cable Extender Box. Connect the opposite end of the extension cable to the terminal (V1 or V2) in MULTICAL®. Connect the cables according to the following combination: 10: Yellow, 9: Red and 11: Blue. This color combination applies to both Cable Extender Box and MULTICAL®. Perform a function check, and complete by sealing Cable Extender Box with the included void labels or the seal labels of the utility.

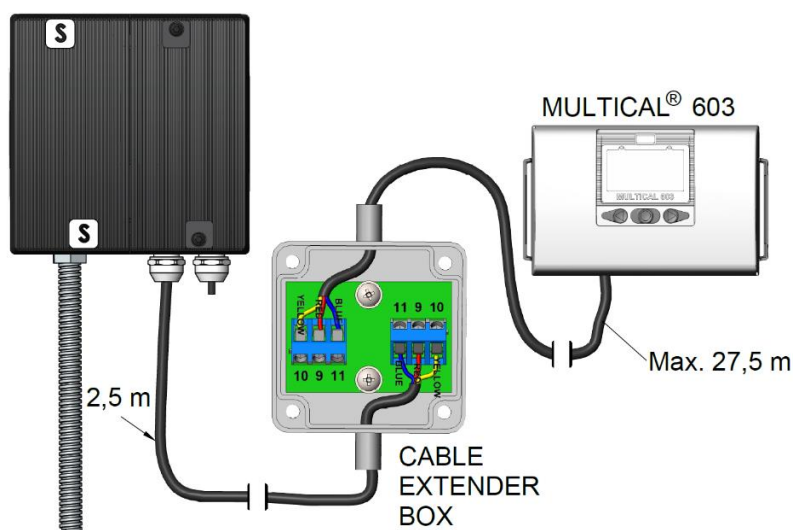

Figure 28. Electrical connection of ULTRAFLOW® 54 DN150-300 with output module Y=1 galvanically coupled to MULTICAL® via Cable Extender Box.

The example illustrates a default 2.5 m cable from ULTRAFLOW® to Cable Extender Box. In this case, the cable length between Cable Extender Box and MULTICAL® can be up to max 27.5 m.

6.13 Installation examples (electrical)

Example of connection of ULTRAFLOW® 54 and MULTICAL®

ULTRAFLOW® 54 with galvanically coupled output module (Y=1), powered by MULTICAL® via a three-wire connection.

6.13.1 See paragraph 6.12.1 for electrical wiring.

⚠ Installed plug in the unused rightmost connector of the electronics box.

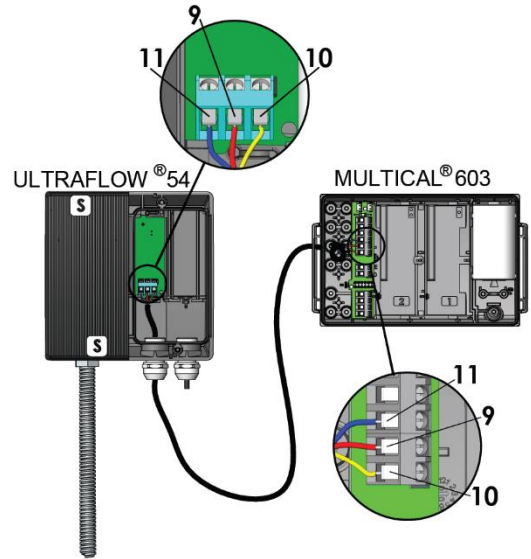

Figure 29. ULTRAFLOW® 54 connected to MULTICAL® 603 via a three-wire connection.

ULTRAFLOW® 54 with galvanically separated output module (Y=2) and 230 VAC supply of its own is connected to MULTICAL® via a two-wire connection.

See paragraph 6.12.2 for electrical wiring.

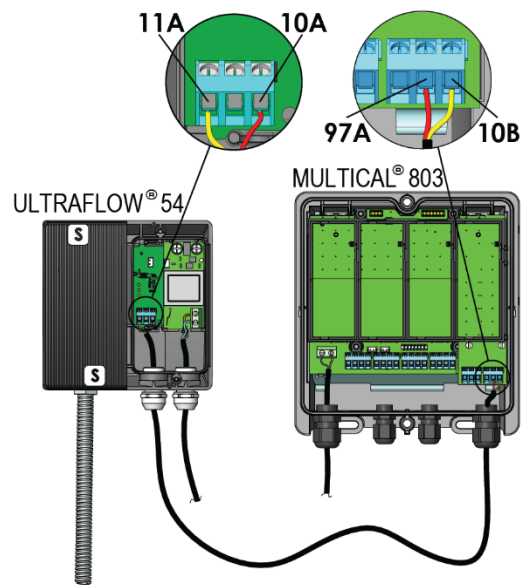

Figure 30. ULTRAFLOW® connected to MULTICAL® 803 via a two-wire connection.

### Calculator with two flow sensors

MULTICAL® 602/603/801/803 can be used in various applications with two flow sensors, e.g. for leak monitoring or in open systems. When two ULTRAFLOW® sensors are direct connected to one MULTICAL®, an equipotential connection (electric low impedance connection) between the two pipes should be carried out as a main rule to protect the meter electronics against transients and potential differences. If the two pipes are installed in a heat exchanger, close to the flow sensors, however, the heat exchanger will provide the necessary electric connection.

In installations where an equipotential connection cannot be carried out, one ULTRAFLOW® flow sensor (typically V2) shall be configured with a galvanically separated output module. ULTRAFLOW® has in this case its own supply.

### Electric welding

If electric welding is performed, the signal cable from ULTRAFLOW® must always be disconnected from the MULTICAL® calculator terminal blocks while the welding is being performed. For meters with two ULTRAFLOW® flow sensors connected to the calculator, both ULTRAFLOW® signal cables must be disconnected.

6.13.3

⚠ Electric welding must always be carried out with the earth pole closest to the welding point. Damage to meters due to welding is **not** comprised by Kamstrup's factory guarantee.

## 6.14 Operational check

Carry out an operational check when the complete meter (flow sensor, temperature sensors and calculator) has been installed and connected. Open thermostats and valves so that water is flowing in the system and check that there are credible values for temperatures and water flow in the calculator display.

## 7 Functional description

Within the heat, cooling and water meter industry, producers have been working on alternative techniques for the replacement of flow sensors based on the mechanical principle. Research and development at Kamstrup have proven that ultrasonic measuring is the most viable solution. Combined with microprocessor technology and piezo ceramics, ultrasonic measuring is not only accurate but also reliable.

### 7.1 Flow measurement with ultrasound

Within ultrasonic flow measuring, there are two main principles: the transit time method and the Doppler method. The Doppler method is based on the frequency change which occurs when sound is reflected by a moving particle. This is the effect you experience when a car drives by. The sound (the frequency) decreases when the car passes by. The transit time method used in ULTRAFLOW® utilizes the fact that it takes an ultrasonic signal, sent in the opposite direction of the flow, longer to travel from transmitter to receiver than a signal sent in the same direction as the flow.

A piezo-ceramic element is used for transmitting and receiving ultrasound. The thickness of the element changes when exposed to an electric field (voltage) and thereby it functions as a transmitter of ultrasound. When the element is mechanically influenced, it generates a corresponding electric voltage and thus functions as a receiver of ultrasound.

### 7.2 Signal path, flow calculation and flow profiles

As proven by the calculations below, the average flow velocity is directly proportional to the transit time difference of ultrasound signals which are sent with or against the flow. *Figure 31* shows as an example the U-shaped signal path and corresponding measuring tube assembly utilized in flow sensors of MULTICAL® 303 and MULTICAL® 403 ( $q_p$  0.6...2.5 m<sup>3</sup>/h) as well as ULTRAFLOW® 44 ( $q_p$  1.5...2.5 m<sup>3</sup>/h) and ULTRAFLOW® 54 (type 65-5-XXHX-XXX,  $q_p$  0.6...2.5 m<sup>3</sup>/h): Piezo-electric elements transmit and receive the ultrasound signal, which is reflected into and through the measuring tube to the receiver via reflectors. Due to superposition of velocities of water and sound signal, ultrasound propagates faster with the flow than against the flow.

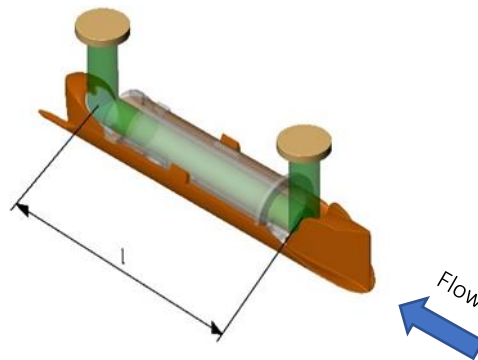

*Figure 31. U-shaped signal path. Sound signals are transmitted by the transducers via 2 reflectors. The signal's transit times with and against the flow vary for the significant sound path distance (parallel with the measuring tube).*

For the calculation of the transit time difference, the signal path along the flow is crucial, and the transit time to the measuring distance is calculated as:

$$t = \frac{l}{c \pm v}$$

where:

$t$  is the transit time from sender to receiver of the sound signal along the measuring distance  $l$ . [s]

$l$  is the measuring distance. [m]

$c$  is the sound propagation velocity in stagnant water. [m/s]

$v$  is the average flow velocity of water. [m/s]

The transit time difference can be expressed as the difference between the absolute time of the signal sent against the flow (-) and the signal sent with the flow (+).

$$\Delta t = \frac{l}{c - v} - \frac{l}{c + v}$$

which can also be written as:

$$\Delta t = l \frac{(c + v) - (c - v)}{(c - v) \cdot (c + v)} \Rightarrow \Delta t = l \frac{2v}{c^2 - v^2}$$

As  $c^2 \gg v^2$ ,  $v^2$  can be omitted and the formula reduced as follows:

$$v = \frac{\Delta t \cdot c^2}{2l}$$

Thus, we know the basic connection between the average flow velocity and the transit time difference.

The transit time difference in a flow sensor is very small (nanoseconds). Therefore, the time difference is measured as a phase difference between the two 1 MHz sound signals in order to obtain the necessary accuracy.

Furthermore, the influence of the temperature of the sound velocity of water must be taken into account. In ULTRAFLOW®, the velocity of ultrasound  $c$  is measured by means of a number of absolute time measurements between the two transducers. As the geometry of the flow sensor is known, the measured speed of the ultrasound is thus a scale for the water temperature, which is further used in the built-in ASIC in connection with the flow calculations.

The flow (volume flow rate) is then determined by measuring the transit time difference, calculate the average flow velocity and multiply it by the area of the measuring tube:

$$q = v \cdot A$$

where:

$q$  is the flow (volume flow rate).  $\left[\frac{m^3}{h}\right]$

$A$  is the area of the measuring pipe.  $[m^2]$

The volume  $V$  passing through is finally calculated as a time integration over the flow (multiplication of (cross section constant) flow by time).

The calculation above is simplified since it does not take into account the flow profiles. In general, flow profiles influence the measurement, which in our case is the transit time difference. Flow sensors are thus adjusted properly according to the different Reynolds numbers that characterize the flow, i.e. in practice for different flows (volume flow) and temperatures. To cover the various flow profiles in the best possible way with the ultrasound signal, Kamstrup uses a triangle sound path, as illustrated in *Figure 32* from two perspectives, for large MULTICAL® 403, ULTRAFLOW® 44 and ULTRAFLOW® 54 flow sensors ( $q_p$  3.5...100 m<sup>3</sup>/h).

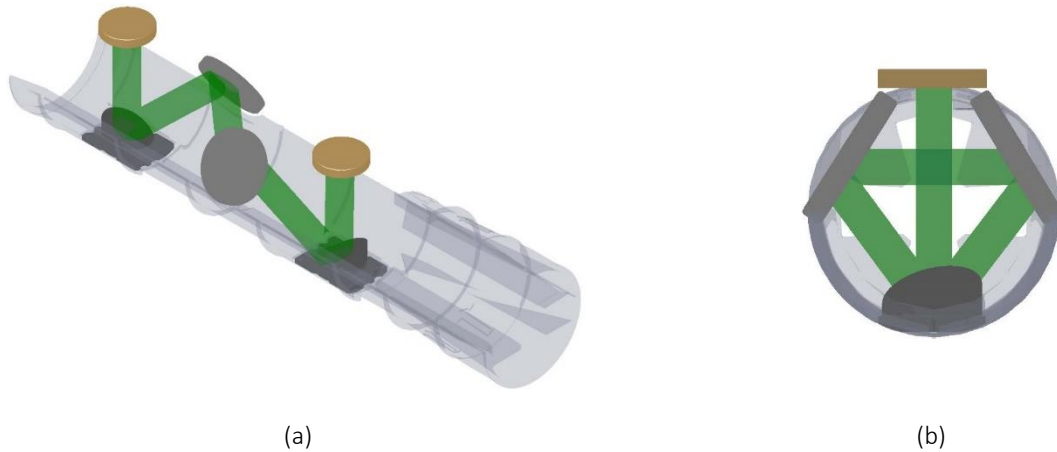

*Figure 32. Triangular signal path shown from the side (a) and when looking into the measuring tube (b). Sound signals are transmitted by the transducers via 4 reflectors along the triangular path.*

ULTRAFLOW® 54 DN150-300 utilizes finally two parallel sound paths at a slant as shown in *Figure 33*.

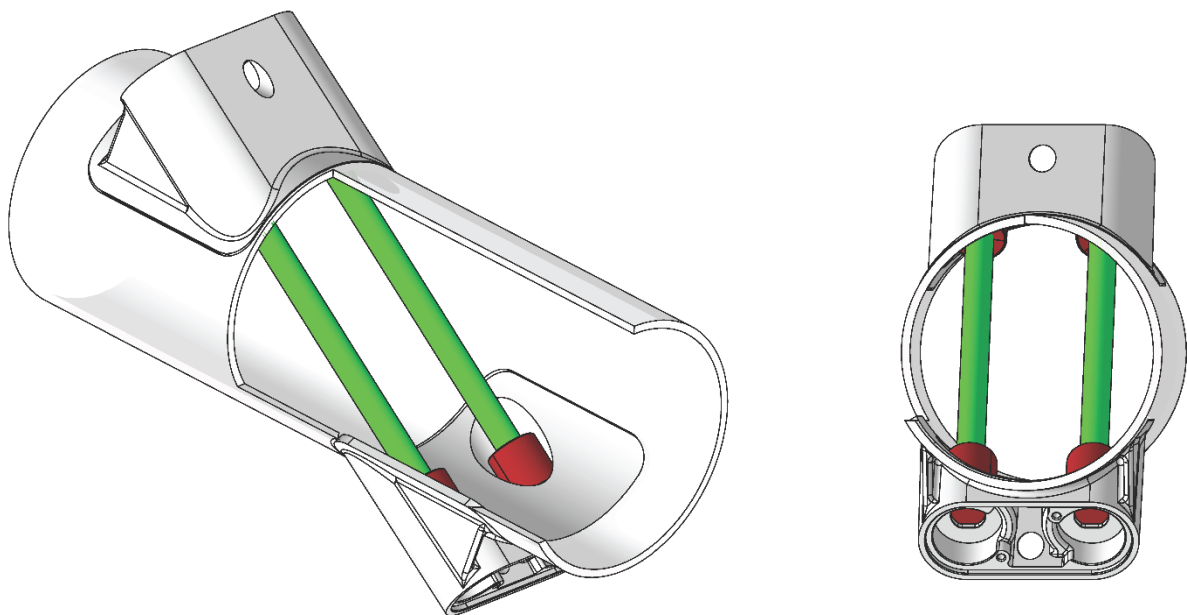

*Figure 33. ULTRAFLOW® 54 ( $q_p$  150...1000 m<sup>3</sup>/h). Two parallel sound paths at a slant in the measuring pipe.*

### 7.3 Function of ULTRAFLOW®

During a flow measurement, ULTRAFLOW® passes through a number of sequences, which are repeated at fixed intervals. Deviations only occur when the flow sensor is in test mode and when the supply is connected during initialization/start-up.

The difference between the main routines in normal mode and fast/test mode is the frequency of the measurements on which pulse emission is based.

In connection with Power Down, it may take up to 16 seconds to start with proper functioning.

In the flow sensor’s working range from min. cut off to saturation flow, there is a linear connection between the flow rate and the number of pulses being emitted. The diagram below shows an example of the connection between flow and pulse frequency for ULTRAFLOW®  $q_p$  150 m<sup>3</sup>/h (Figure 34).

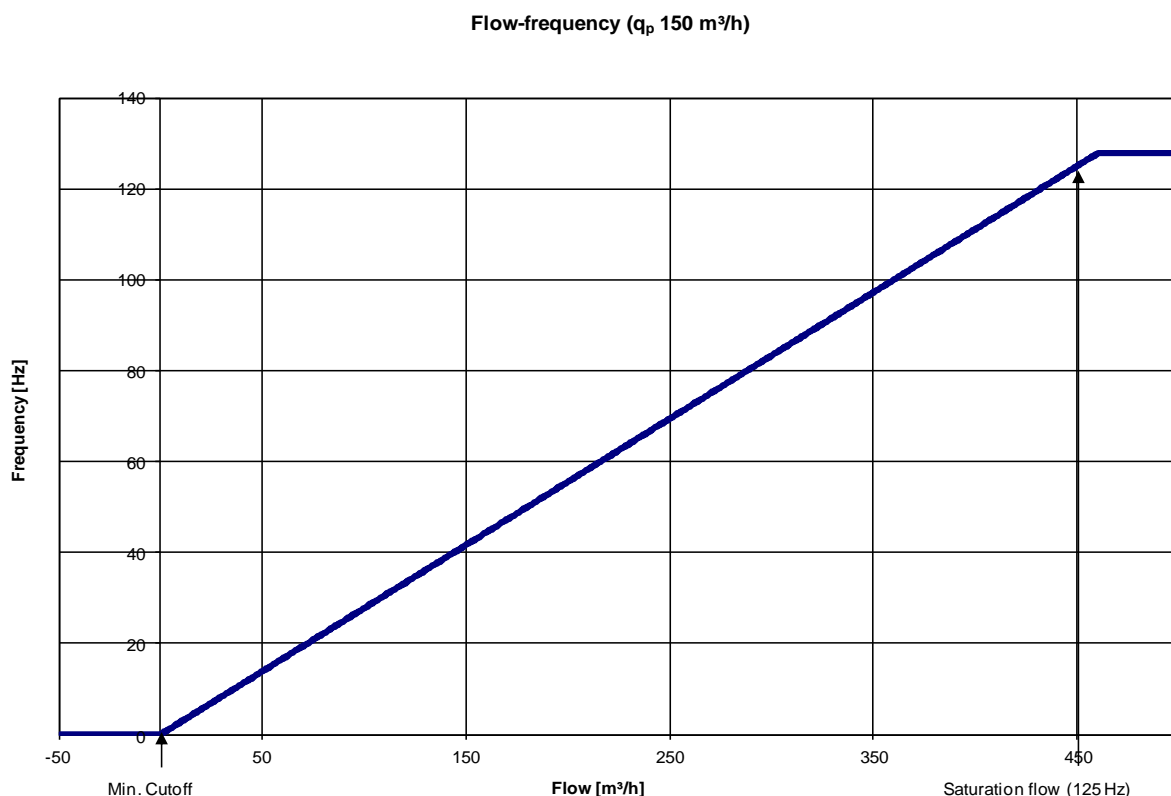

Figure 34. Pulse frequency as a function of flow  $q_p$  150 m<sup>3</sup>/h.

If the flow is lower than min. cut off or negative (backward flow), ULTRAFLOW® does not emit pulses.

At flows exceeding the flow corresponding to pulse emission at max pulse frequency, the max pulse frequency will be maintained.

Table 13 shows the saturation flow at a pulse frequency of 125 Hz for the different flow sizes and meter factors.

$q_p$ [m <sup>3</sup> /h]	Meter factor [p/l]	Flow at 125 Hz [m <sup>3</sup> /h]
150	1	450
250	0.6	750
400	0.4	1125
600	0.25	1800
1000	0.15	3000

Table 13. Flow rate at saturation flow (125 Hz).

According to EN 1434 the upper flow limit  $q_s$  is the highest flow at which the flow sensor may operate for short periods of time (<1h/day, <200 h/year), without exceeding max. permissible error. ULTRAFLOW® has no functional limitations during the period when the flow sensor operates above  $q_p$ .

Please note, however, that high flow velocities may cause cavitation, especially at low static pressure. See paragraph 6.1.4 *Operating pressure*.

## 7.4 Pulse emission

Pulses are emitted at 1-second intervals. The number of pulses to be emitted is calculated every second. Pulses are emitted in bursts with a pulse duration of 2...6 ms and pauses depending on the current pulse frequency. The duration of the pauses between the individual bursts is approx. 30 ms.

The transmitted pulse signal is the average determination of a series of flow measurements. This means that there will be a transient phenomenon until correct flow signal has been obtained during start-up. Furthermore, this brings about a pulse tail of up to 8 seconds in case of sudden hold.

## 7.5 Supply and power consumption of ULTRAFLOW®

Normally, ULTRAFLOW® is supplied by the connected MULTICAL® calculator. When ULTRAFLOW® is supplied in any other way, for example via direct connection in a flow bench, the following applies:

Internal supply voltage of ULTRAFLOW®:

3.6 VDC ±0.1 VDC

The current consumption of ULTRAFLOW®:

Max average            50 µA

Max current            7 mA (max 40 ms)

## 7.6 Pulse output of ULTRAFLOW®

### Galvanically coupled

Galvanically coupled output module (Y=1). ULTRAFLOW® is powered by MULTICAL®.

⚠ ULTRAFLOW® must not be mounted with a supply.

Cable length ULTRAFLOW® to MULTICAL® Max. 10 m

7.6.1	Type	Push-Pull
	Output impedance	~10 kΩ

Concerning meter factor and pulse durations, see *paragraph 4.2.3*

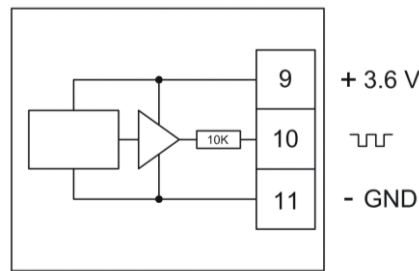

Figure 35. Block diagram of galvanically coupled output module (Y=1) in ULTRAFLOW® 54.

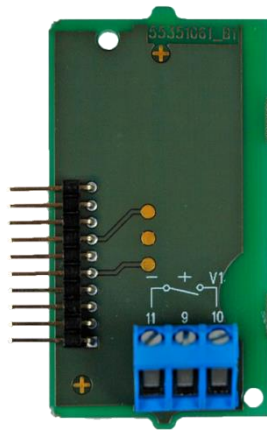

Figure 36. Galvanically coupled output module (Y=1).

**Galvanically separated**

Galvanically separated output module (Y=2). ULTRAFLOW® is powered by the built-in supply module (Z=7 or 8).

Cable length to ULTRAFLOW® depends on calculator. When connected to MULTICAL® maximum cable length is 100 meters (2-wire connection).

To calculator:

- 7.6.2      Type:                                      Open collector.
- Connection:                              Can be connected as two-wire or as three-wire via the built-in 56.2 kΩ pull-up.

Module Y=2	OC and OD	(OB) Kam
Max input voltage	6 V	30 V
Max input current	0.1 mA	12 mA
ON condition	$U \leq 0.3 \text{ V @ } 0.1 \text{ mA}$	$U_{CE} \leq 2.5 \text{ V @ } 12 \text{ mA}$
OFF condition	$R \geq 6 \text{ M}\Omega$	$R \geq 6 \text{ M}\Omega$

Table 14

Concerning meter factor and pulse durations, see paragraph 4.2.3

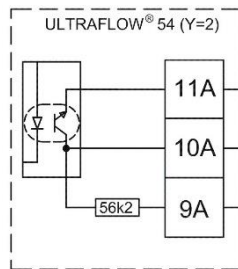

Figure 37. Block diagram of galvanically separated output module (Y=2) in ULTRAFLOW® 54.

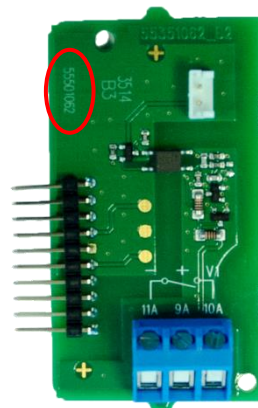

Figure 38. Galvanically separated output module (Y=2).  
Note the PCB number 5550-1062 in the encircled area.

Galvanically separated output module (Y=3). ULTRAFLOW® is powered by the built-in supply (Z=2, 7 or 8).  
 Cable length to ULTRAFLOW® depends on calculator. When connected to MULTICAL® maximum cable length is 10 meters.

To calculator:

Type: Open collector.  
 Connection: Three-wire via the built-in 39.2 kΩ pull-up.

Module Y=3	OC and OD
Max input voltage	6 V
Max input current	0.1 mA
ON condition	$U \leq 0.3 \text{ V @ } 0.1 \text{ mA}$
OFF condition	$R \geq 6 \text{ M}\Omega$

Table 15

Concerning meter factor and pulse durations, see paragraph 4.2.3

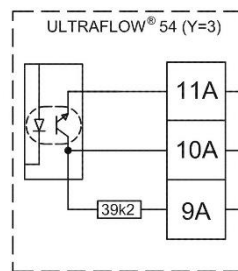

Figure 39. Block diagram of galvanically separated output module (Y=3) in ULTRAFLOW® 54.

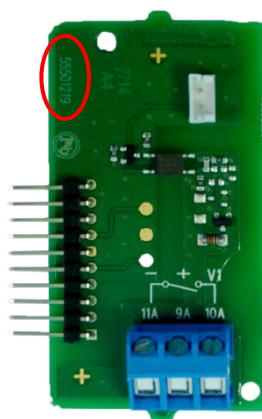

Figure 40. Galvanically separated output module (Y=3).  
 Note the PCB number 5550-1219 in the encircled area.

## 7.7 Interface connector/serial data

ULTRAFLOW® 54 is fitted with a four-pole connector under the cover. The cover is supplied with a factory seal, and in connection with verified sensors it will be a laboratory seal (legal seal). Thus, it is not possible to access the connector without breaking the seal.

The connector is used for:

- Bringing the sensor into test mode
- External control of start/stop in connection with calibration
- Reading accumulated water quantity in connection with calibration
- Meter programming, including adjustment of correction curve by means of METERTOOL

The interface connector is constructed as shown in *Figure 41*.

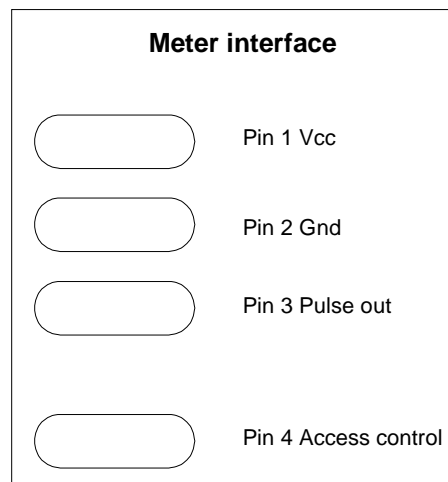

*Figure 41. Interface connector.*

### 7.8 Test mode

To minimize the time spent on calibration, ULTRAFLOW® 54 can be switched into test mode. When ULTRAFLOW® is in test mode (verification mode), the measuring routines only take one fourth of the time they take in normal mode.

ULTRAFLOW® is put into test mode by connecting pin 4 (Verification/Adjustment) on the internal connector to ground (GND), which is located at pin 1 or 2, respectively (see *Figure 41*) and subsequently connecting the supply. After approx. 1 second, the sensor goes into test mode and the connection between pin 4 and frame must be disconnected again.

Test mode is ended automatically by disconnecting the supply to the sensor.

✨ ULTRAFLOW® in test mode uses approx. 3 times as much power as in normal mode. However, this does not influence the total battery lifetime of the energy meter as the total duration of ULTRAFLOW® in test mode is negligible compared to the operating time of ULTRAFLOW® outside test mode.

### 7.9 Externally controlled start/stop

In connection with calibration by means of serial data, e.g. in connection with NOWA, ULTRAFLOW® 54/34 can be monitored by an external signal when it is in verification mode (see *paragraph 7.8 Test mode*). This is done by grounding pin 4 of the internal plug when starting the test and removing it when the test has been completed. The volume of water that has been accumulated during the test can be read serially.

The accumulation is based on the same data as those used for calculating the number of pulses to be emitted.

In addition to accumulating water volume during test, the sensor corrects for the excess quantity in connection with start as well as the quantity lacking in connection with stop. These deviations are due to the fact that the sensor measures flow and calculates volume at fixed intervals as illustrated in *Figure 42*.

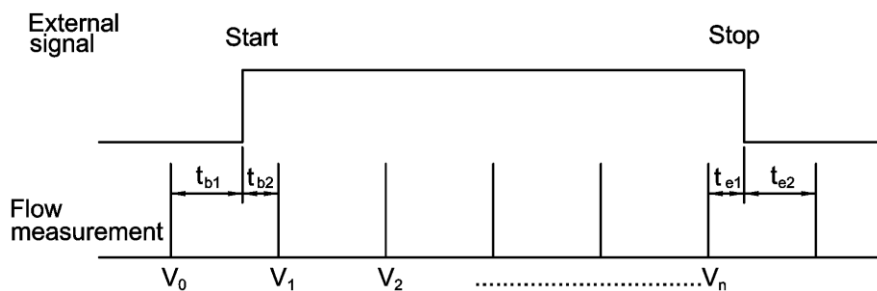

Figure 42

The excess quantity of water in connection with start is the water volume that passes through the sensor during the time  $t_{b1}$  before the first accumulation  $V_1$  within the test period. In the same way the lacking quantity is the water volume passing through the sensor during the time  $t_{e1}$  from the last accumulation  $V_n$  until stop.

The volume accumulated during the test can be stated as:

$$V_{test} = \frac{t_{b2}}{t_{b1} + t_{b2}} \cdot V_1 + V_2 + \dots + V_n + \frac{t_{e1}}{t_{e1} + t_{e2}} \cdot V_n$$

## 7.10 Calibration using serial data and externally controlled start/stop

The routine for calibrating ULTRAFLOW® using serial data is outlined below.

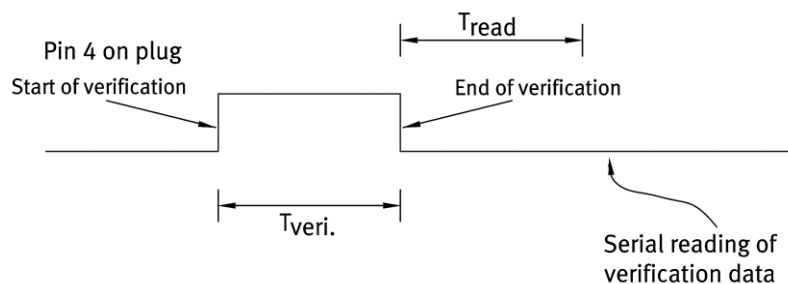

Figure 43

The sensor must be in test mode (see *paragraph 7.8 Test mode*).

Calibration is started by grounding pin 4 of the internal connector (see *Figure 43*) and at the same time starting the test in a flow stand. This might e.g. take place at the same time as the master meter starts accumulating pulses or the diverter of the weight is changed. Then, ULTRAFLOW® accumulates the water volume until pin 4 is disconnected to terminate the test. Subsequently, the volume accumulated during the test can be read in consideration of start and stop. From the test has been completed and until the accumulated quantity of water can be read, minimum 2 seconds must pass ( $T_{read}$ ). Communication with ULTRAFLOW® during test is not allowed.

Pulse emission stops when pin 4 is disconnected. The read water quantity and the number of emitted pulses may differ as the pulse emission is monitored at intervals of 1 second.

## 7.11 Accuracy

ULTRAFLOW® 54 has been developed as a volume flow rate sensor for energy meters according to EN 1434. The tolerances permitted for flow sensors according to EN 1434 with a dynamic range of 100:1 ( $q_p:q_i$ ) and  $q_p$  150 m<sup>3</sup>/h are shown in *Figure 44*. The tolerances are defined for class 2 and class 3 with the following formulas:

Class 2:  $\pm 2 + 0.02 \times \frac{q_p}{q}$  %, however max.  $\pm 5$  %

Class 3:  $\pm 3 + 0.05 \times \frac{q_p}{q}$  %, however max.  $\pm 5$  %

EN 1434 defines the following dynamic ranges ( $q_p:q_i$ ): 10:1, 25:1, 50:1, 100:1 and 250:1.

In connection with accuracies the range from  $q_p$  to  $q_s$  is defined as max. flow, where the meter must short-term (< 1 h/day; < 200 h/ year) be functioning and tolerances are adhered to. There are no requirements to the relation between  $q_p$  and  $q_s$ . See *Table 1* for information on  $q_s$  for ULTRAFLOW®.

To render probable that the sensors meet the tolerance requirements, EN 1434-5 specifies calibration requirements in connection with verification of sensors. It is required that flow sensors are tested at the following 3 points:

$q_i \dots 1.1 \times q_i$ ,  $0.1 \times q_p \dots 0.11 \times q_p$  and  $0.9 \times q_p \dots q_p$

During test the water temperature must be 50 °C  $\pm$ 5 °C for ULTRAFLOW® as a heat meter.

For ULTRAFLOW® as a cooling meter the water temperature must be 15 °C  $\pm$ 5 °C.

Further requirements are that the tolerance of the equipment used to perform the test must be less than 1/5 MPE (Maximum Permissible Error) to permit the acceptance limit to be equal to MPE. If the equipment does not observe 1/5 MPE, the acceptance limit must be reduced by the tolerance of the equipment.

ULTRAFLOW® will typically do better than half of the permitted tolerance according to EN 1434 class 2.

☀ For further information regarding allowable test conditions such as water temperature and flow of the individual ULTRAFLOW®, see the approval of ULTRAFLOW® (see *paragraph 10 Approvals*).

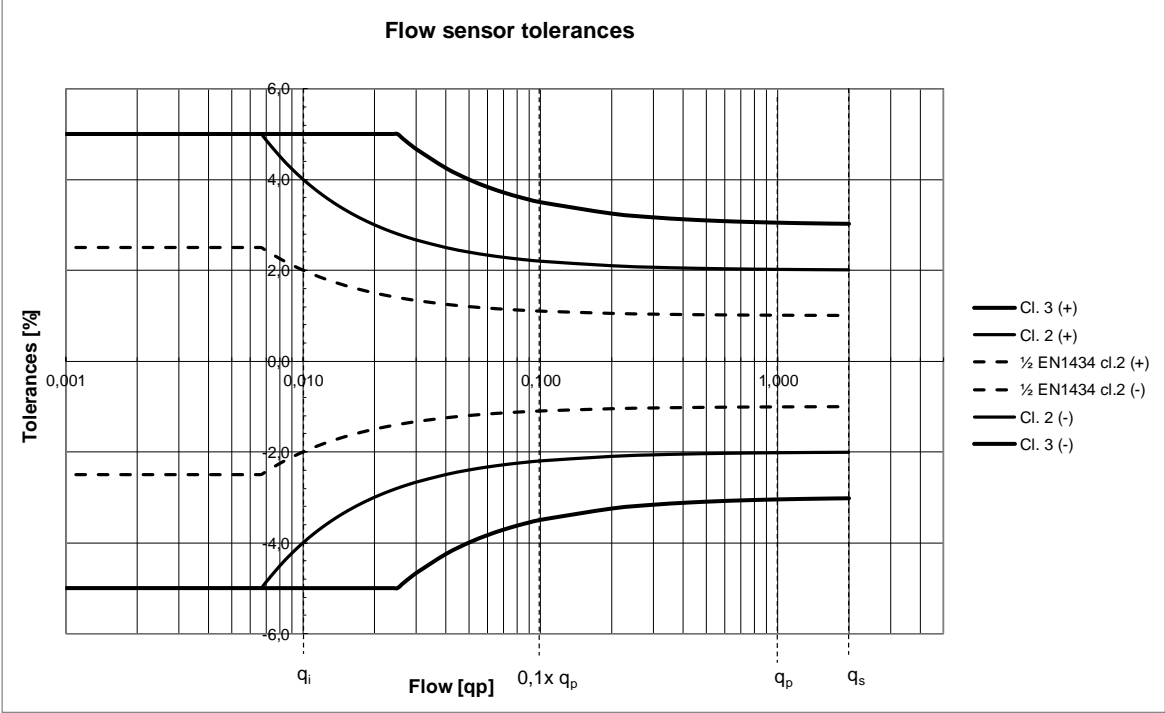

Figure 44. Flow sensor tolerances specified as an example for a flow sensor with  $q_p:q_i = 100:1$  and  $q_p:q_s = 1:2$ .

## 8 Calibration, adjustment and sealing of ULTRAFLOW® 54

Calibration can be based on:

- Pulses in standard mode
- Pulses in test mode
- Pulses using Pulse Tester type 66-99-279
- Serial data with the sensor in test mode

### 8.1 Technical data for ULTRAFLOW®

ULTRAFLOW® emits flow-proportional pulses depending on programming (see type label and *Table 6*). If ULTRAFLOW® is connected to equipment other than MULTICAL® calculators, for example a flow bench, it is recommended to use galvanic separation.

Internal supply: 3.6 VDC ±0.1 VDC

Pulse duration: 2...100 ms depending on programming. Appears from type label.

Meter factor: Depends on programming. Appears from type label.

Start-up: It takes 16 seconds from start-up until true flow reading has been obtained and calibration can start.

## 8.2 Electrical connection

### Galvanically coupled output module (Y=1).

Type: Push-Pull

Output impedance ~ 10 kΩ

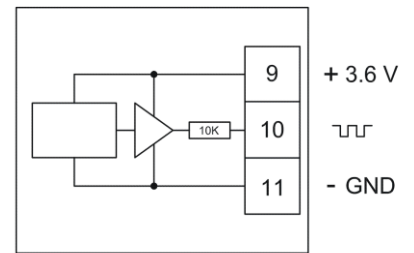

Figure 45

### Galvanically separated output module (Y=2).

Open collector. Two-wire or three-wire via the built-in pull-up of 56.2 kΩ

Module Y=2	OC and OD	(OB) Kam
Max input voltage	6 V	30 V
Max input current	0.1 mA	12 mA
ON condition	$U \leq 0.3 \text{ V @ } 0.1 \text{ mA}$	$U_{CE} \leq 2.5 \text{ V @ } 12 \text{ mA}$
OFF condition	$R \geq 6 \text{ M}\Omega$	$R \geq 6 \text{ M}\Omega$

Table 16

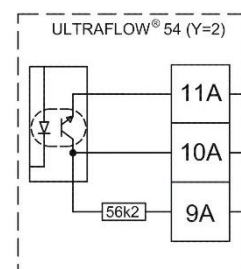

Figure 46

### Galvanically separated output module (Y=3).

Open collector. Three-wire via the built-in pull-up of 39.2 kΩ

Module Y=3	OC and OD
Max input voltage	6 V
Max input current	0.1 mA
ON condition	$U \leq 0.3 \text{ V @ } 0.1 \text{ mA}$
OFF condition	$R \geq 6 \text{ M}\Omega$

Table 17

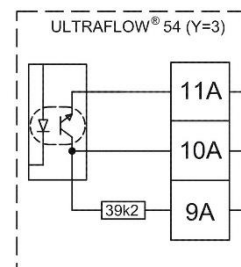

Figure 47

### 8.3 Suggested test points

Nom. flow $q_p$ [m <sup>3</sup> /h]	Meter factor [pulses/l]	Test points			Test duration			Test quantities		
		$q_p$ [m <sup>3</sup> /h]	$q_i$ [m <sup>3</sup> /h]	$0.1 \times q_p$ [m <sup>3</sup> /h]	$q_p$ [min]	$q_i$ [min]	$0.1 \times q_p$ [min]	$q_p$ [kg]	$q_i$ [kg]	$0.1 \times q_p$ [kg]
150	1	150	1.5	15	3	20	6	7500	500	1500
250	0.6	250	2.5	25	3	20	6	12500	833	2500
400	0.4	400	4	40	3	19	6	20000	1250	4000
600	0.25	600	6	60	3	20	6	30000	2000	6000
1000	0.15	1000	10	100	3	20	6	50000	3400	10000

Table 18. Table for ULTRAFLOW® including suggested test points, test durations and test quantities.

The suggested test parameters are based on EN 1434-5 and  $q_p:q_i$  100:1.

The test set-ups have been selected on the basis of the following requirements:

- Minimum test duration of 3 minutes
- Water volumes at  $q_i$  and  $0.1 \times q_p$  of minimum 10 % of the water volume per hour
- Water volume at  $0.1 \times q_p$  corresponding to minimum 1000 pulses
- Water volume at  $q_i$  corresponding to minimum 500 pulses

These suggested test points can be optimized for the test benches as well as for the test purpose.

## 8.4 Optimization in connection with calibration

To make a rational test of ULTRAFLOW®, it must be possible to reproduce the test results. This is also very important if the tested sensors are to be adjusted.

Experience based on 300...500 pulses at  $q_i$ , 3000...5000 at  $q_p$ , and flying start/stop shows that ULTRAFLOW® operates with standard deviations of 0.3...0.4 % at  $q_i$  and 0.2...0.3 % at  $q_p$ .

In connection with optimization of calibration, the following subcomponents can be considered:

**Pressure:** Optimal working pressure is 4...6 bar of static pressure. This minimizes the risk of air and cavitation.

**Temperature:** Calibration temperature according to EN 1434-5 is 50 °C ±5 °C for heat meters and 15 °C ±5 °C for cooling meters.

☀ For further information regarding allowable test conditions such as water temperature and flow of the individual ULTRAFLOW®, see the approval of ULTRAFLOW® (see *paragraph 10 Approvals*).

**Water quality:** Recommended water quality as described in CEN TR 16911 and AGFW FW510

### Installation (mechanical conditions):

To avoid flow disturbances, the inlet pipes and distance pieces must have the same nominal diameter as the sensors. There should be min. 5 x DN between the sensors. In connection with bends, etc., there should be a minimum distance of 10 x DN. If tests are made at low flow with a bypass at right angles to the pipe, it will be an advantage to mount an absorber of pressure fluctuations due to the perpendicular inlet. This can be a flexible tube on the bypass. In addition, it will be an advantage to mount a flow straightener before the first distance piece. Flow disturbances such as pulsations, e.g. pump fluctuations must be minimized. In connection with calibration, a code of practice for distance pieces has been made on the basis of many years' experience:

The lengths of the distance pieces must be 10 x DN.

### Installation (electrical conditions):

To avoid interference from the outside as well as to obtain an electrical interface to MULTICAL®, it is recommended to use a Pulse Tester (see *paragraph 8.5*) or to connect ULTRAFLOW® and the relevant test equipment that count pulses via a galvanically separated output module.

## 8.5 Pulse Tester

During a calibration process it is often practical to use Pulse Tester type No. 66-99-279 with the following functions:

- Galvanically separated pulse outputs
- Integral supply for ULTRAFLOW®
- LCD-display with counter
- Externally controlled "Hold" function
- Can be mounted directly in a MULTICAL® base unit (type 66- and 602-)

### Technical data of Pulse Tester

Pulse inputs (M1/M2)

Counter inputs	Max. frequency: 128 Hz
8.5.1 Active signal	Amplitude: 2.5 - 5 Vpp
Pulse duration	> 1 ms
Passive signal	Internal pull-up 680 kΩ
Internal supply	3.65 V lithium battery

**Please note:** Depending on the connecting base used there are one or two pulse inputs/outputs.

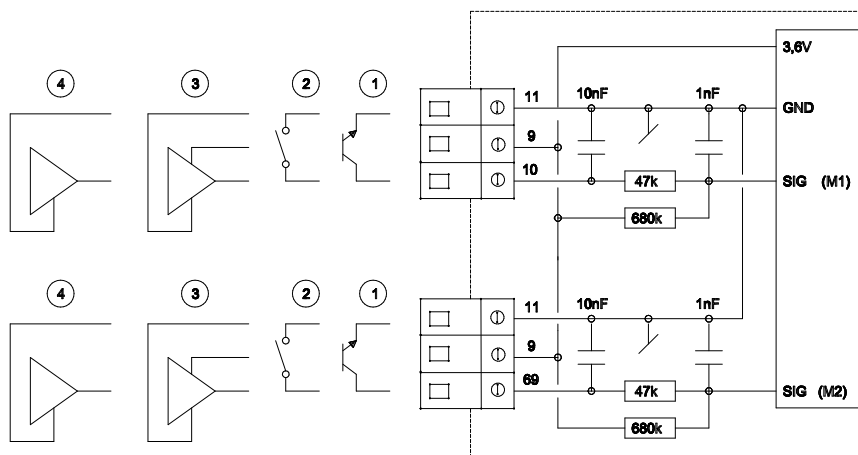

Figure 48

#### 1 Flow sensor with transistor output

The transmitter is normally an optocoupler with FET or transistor output to be connected to terminals 10 and 11 for water meter M1 or terminals 69 and 11 for water meter M2.

The leak current of the transistor must not exceed 1 µA in off-state, and  $U_{CE}$  in on-state must not exceed 0.5 VDC.

#### 2 Flow sensor with relay or reed-switch output

The transmitter is a reed-switch, which is normally mounted on vane wheel and Woltmann meters, or the relay output of e.g. MID-meters. This type of transmitter should not be used as the quick pulse input of the Pulse Tester may regard bounce from the transmitter as pulses.

3 **Flow sensor with active pulse output, powered by the Pulse Tester**

This connection is used together with either Kamstrup’s ULTRAFLOW® or Kamstrup’s electronic pick-up for vane wheel meters.

Connection (M1)	9: Red (9A)	10: Yellow (10A)	11: Blue (11A)
Connection (M2)	9: Red (9A)	69: Yellow (10A)	11: Blue (11A)

Table 19

4 **Flow sensor with active output and integral supply**

Flow sensors with active signal output are connected as shown in *Figure 49*. The signal level must be between 3.5 V and 5 V. Higher signal levels can be connected via a passive voltage divider, e.g. of 47 kΩ/10 kΩ at a signal level of 24 V.

**Pulse outputs (M1/M2)**

Pulse duration > 4 ms  
 Duration of pause Depending on the actual pulse frequency

**Two-wire connection:**

Voltage < 24 V  
 Load > 1.5 kΩ

**Three wire connection:**

Voltage 5...30 V  
 Load > 5 kΩ

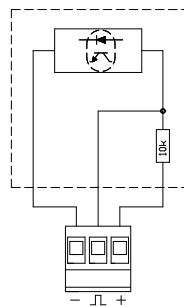

Figure 49

The outputs are galvanically separated and protected against overvoltage and reversed polarity.

Max. counter capacity before overflow is 9,999,999 counts.

### Hold-function

When the Hold input is activated (high level applied to input), counting stops at the counted pulse figure.

When the Hold signal is removed (low level applied to input), counting restarts.

The counters can also be reset by pressing the right key on the front panel (Reset).

8.5.2	Hold input	Galvanically separated
	Input protection	Against reversed polarity
	“Open input”	Count (see <i>Figure 50</i> )

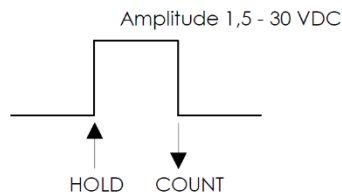

*Figure 50*

### Push-button functions

8.5.3



*Figure 51. The left push-button shifts between readings/counts of the two flow sensor inputs. In the display, M1 and M2 respectively indicate the currently displayed flow sensor inputs/counters.*

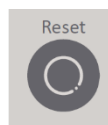

8.5.4

*Figure 52. The right push-button “Reset”.*

### Using Pulse Tester

The Pulse Tester can be used as follows:

Standing start/stop of flow sensor using the integral pulse counters.

Standing start/stop of flow sensor using the pulse outputs for external test equipment.

Flying start/stop of flow sensor using the integral counters controlled by external equipment (Sample & Hold).

Flying start/stop of flow sensor using the pulse outputs controlled by external equipment (Sample & Hold).

Spare parts

8.5.5

Description	Type No.
Battery D-cell	1606-064
Cable retainer (secures the battery)	1650-099
2-pole plug (female)	1643-185
3-pole plug (female)	1643-187
PCB (66-R)	5550-517

Table 20. Spare parts for Pulse Tester.

**Battery replacement**

If the Pulse Tester is used continuously, we recommend that the battery is replaced once a year.

8.5.6 Remove the battery plug from the battery and strip the cable insulation before connecting the battery to the terminals marked "Batt", the red wire to + and the black one to -.

Current consumption:

Current consumption with no sensors connected	400 µA
Max. current consumption with two ULTRAFLOW® connected	1.5 mA

⚠ If the base unit is fitted with battery or externally supplied, the Pulse Tester's integral supply must be disconnected (unplugged).

## 8.6 Adjustment of ULTRAFLOW® flow sensors with Kamstrup software

Adjusting of ULTRAFLOW® flow sensors is supported by Kamstrup for authorized laboratories. The adjustment is performed through Kamstrup's software METERTOOL HCW 6699-724 or LabTool. Please contact the Kamstrup Product Service in Denmark ([service@kamstrup.com](mailto:service@kamstrup.com)) for additional information.

💡 To prevent any attempt of fraud, LabTool is exclusively distributed to workshops/laboratories with national legal authorization and partnership with Kamstrup.

## 8.7 Sealing and marking

ULTRAFLOW® is factory sealed. Verified sensors will be supplied with security seals (S) and a year mark (D).

If the seal of a verified sensor is broken, the sensor must be verified before being installed in a location demanding verification.

⚠️ According to WELMEC 13.3:2021 installation sealing is advisable. The shown methods for installation sealing are examples, but other securing measures for the installation may be equally suitable. National requirements concerning installation sealing shall be taken into account.

Sealing of ULTRAFLOW® 54 is shown below.

In the drawings, sealing is divided into the following groups:

- D Security seal or module D/F label (depending on type label).
- S Security seals. Covering screws or parts of type label.
- T Type label (as void label or with security seal D).
- I Installation seal (wire and seal or void label).
- A Alternative approval marking. Either as an integrated part of the type label or covering the type label (e.g. DK268 mark or DK268 mark and year mark).
- R Re-verification marking (suggested position).

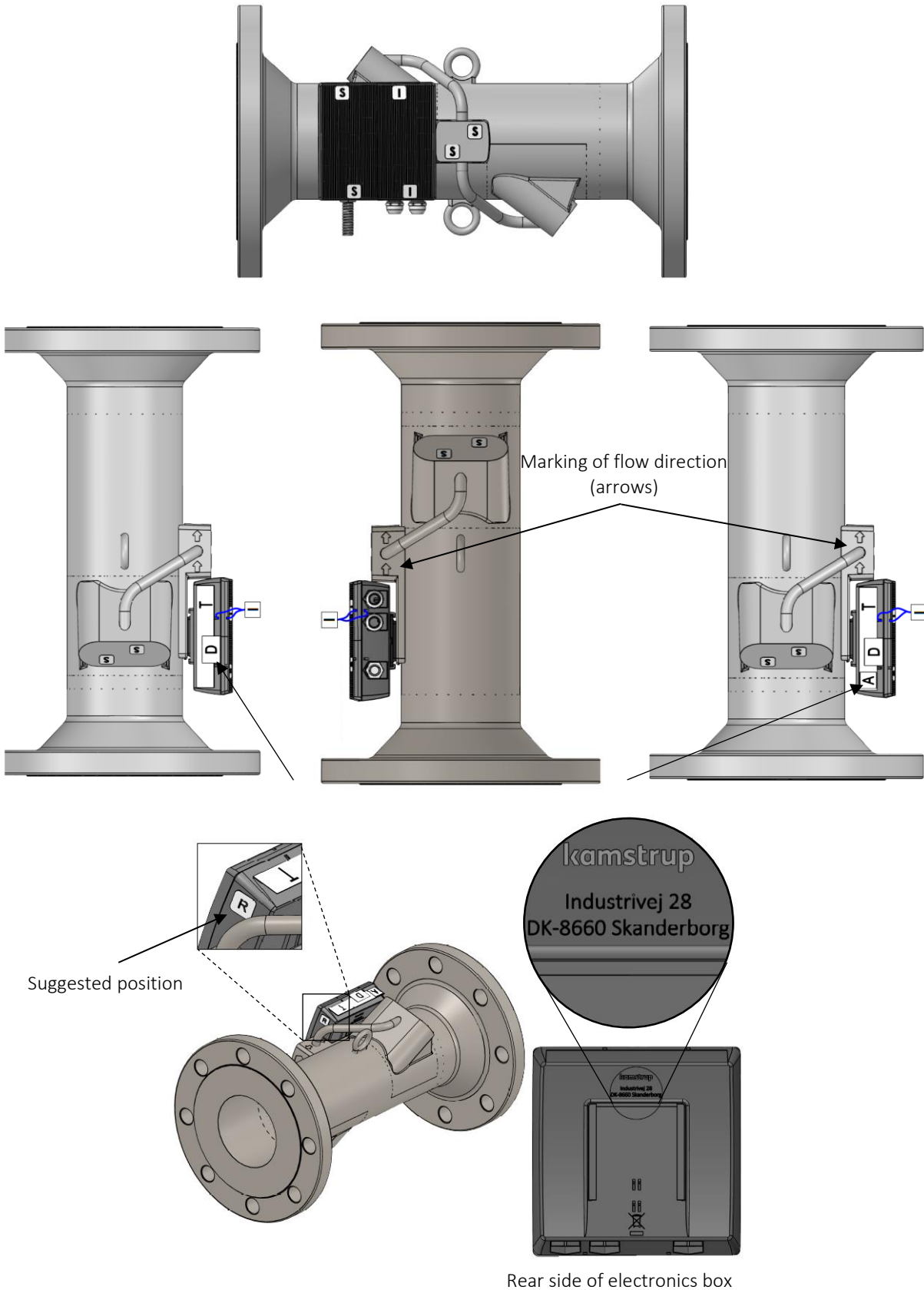
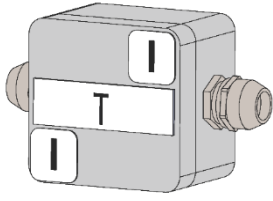
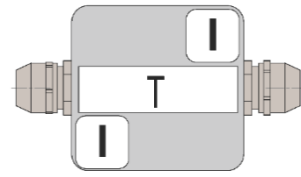

Figure 53. Sealing and marking of ULTRAFLOW® 54 DN150-300.



(a)



(b)

Figure 54. Sealing of Cable Extender Box seen from the front (a) and from the side (b).

## 9 Software for Kamstrup heat/cooling meters

Adjusting of ULTRAFLOW® flow sensors is supported by Kamstrup for authorized laboratories. The adjustment is performed through Kamstrup's software METERTOOL HCW 6699-724 or LabTool. Please contact the Kamstrup Product Service in Denmark ([service@kamstrup.com](mailto:service@kamstrup.com)) for additional information.

To program Pulse Divider and to configure pulses in ULTRAFLOW® 54 DN150-300, the software METERTOOL HCW 6699-724 is used. For more information, see the Technical description of METERTOOL HCW (FILE100002360\_EN\_(5512-2097\_GB)).

To adjust ULTRAFLOW® 54, see *8.6 Adjustment of ULTRAFLOW® flow sensors with Kamstrup software*.

## 10 Approvals

### 10.1 MID and DK-BEK 1178 – 06/11/2014

ULTRAFLOW® 54 is available as a flow sensor for heating installations with CE-marking according to MID (2014/32/EU). The certificates have the following numbers:

EC-Type Examination certificate (B-Module): DK-0200-MI004-008

MID-certificate acc. to Module D: DK-0200-MID-D-001

ULTRAFLOW® 54 is approved as a cooling flow sensor in accordance with DK-BEK 1178 – 06/11/2014:

System designation: TS 27.02 002

Verification: DANAK accreditation 268

Please contact Kamstrup A/S for further details on type approval and verification.

Standard and documents:

EN 1434:2007/AC2007

EN 1434:2015+A1:2018

EN 1434:2022

OIML R75:2002

WELMEC 7.3:2023 (May 2024).

### 10.2 CE-Marking

In addition, ULTRAFLOW® 54 is marked according to the following directives, where necessary:

EMC directive 2014/30/EU

LV directive 2014/35/EU (when fitted with 230 VAC supply module)

PE directive 2014/68/EU (DN150...DN300) category II

### 10.3 Declaration of Conformity (EU)

With each ULTRAFLOW® 54 DN150-300 delivered from Kamstrup, an EU Declaration of Conformity is provided. See Kamstrup documentation no. 5512-1996.

## 11 Troubleshooting

Before sending in the sensor for repair or testing, please use the error detection table below to help you clarify the possible cause of the problem.

Symptom	Possible cause	Proposal for correction
No update of display values	No power supply	Replace battery or check mains supply
No display function (blank display)	No power supply and backup	Replace back-up cell. Replace battery or check mains supply
No accumulation of m <sup>3</sup>	No volume pulses Incorrect connection	Check flow sensor connection. (Check with Pulse Tester, if necessary)
	Flow sensor inverted	Check flow sensor direction
	Air in sensor/cavitation	Check installation angle. Check if there is air in the system or cavitation from valves and pumps. If possible, try to increase the static pressure.
	Flow sensor error	Replace flow sensor/send sensor for repair
Erroneous m <sup>3</sup> accumulation	Erroneous programming	Check consistency between meter factor of calculator and flow sensor
	Air in sensor/cavitation	Check installation angle. Check if there is air in the system or cavitation from valves and pumps. Increase the static pressure, if possible
	Flow sensor error	Replace flow sensor/Send sensor for repair

Table 21. Troubleshooting for heat and cooling meters.

## 12 Disposal

Kamstrup A/S holds an environmental certification according to ISO 14001, and as part of Kamstrup’s environment policy, materials that can be recovered environmentally correctly are used to the greatest possible extent.

Kamstrup A/S has climate accounts (Carbon footprint) for all meter types.



Kamstrup's heat meters are marked according to EU Directive 2012/19/EU and the standard EN 50419.

The purpose of the marking is to inform our customers that the heat meter cannot be disposed of as ordinary waste.

- **Disposal by Kamstrup A/S**

Kamstrup A/S accepts worn-out meters for environmentally correct disposal according to previous agreement. The disposal is free of charge to our customers, except for the cost of transportation to Kamstrup A/S.

- **The customer sends for disposal**

The meters must not be disassembled prior to dispatch. The complete meter is handed in for approved national/local disposal. Enclose a copy of this page in order to inform the recipient of the contents.

Lithium cells and meters including lithium cells must be packed, marked and forwarded as dangerous goods (see also Kamstrup document 5510-408, "Lithium batteries - Handling and disposal"). Batteries must NOT be subject to mechanical shock and the cables must NOT be able to be short circuited during transport.

Meter part	Material	Recommended disposal
Lithium cell (D-cell)	Lithium and thionyl chloride > UN 3091 < D-cell: 4.9 g lithium	Approved deposit of lithium cells
PCB	Coppered epoxy laminate, components soldered on	PCB scrap for concentration of metals
Signal cable for flow sensor	Copper with silicone mantle	Cable recycling
Supply cable	Copper with PVC mantle	Cable recycling
Electronics box, base & cover	Thermoplastic, PC 10% GF	Plastic recycling
Mounting fitting, bracket for electronics box	Thermoplastic, PPS 40% GF	Plastic recycling
Housing, Cable Extender Box	Thermoplastic, ABS	Plastic recycling
ULTRAFLOW® sensor housing	Stainless steel, W.no. 1.4307	Metal recycling
Transducer holder	Stainless steel, W.no. 1.4308	Metal recycling
Transducer	Titanium	Metal recycling
Packing	Recycled cardboard and EPS	Cardboard and EPS recycling (Resy)

Please send any questions you may have regarding environmental matters to:

**Kamstrup A/S**  
 Att.: Quality and environmental dept.  
 Fax: +45 89 93 10 01  
 info@kamstrup.com

## 13 Technical documentation

	Danish	English	German
<b>Technical description</b>			
ULTRAFLOW® 54 DN15-125	FILE100001275_DK (5512-2463)	FILE100001282_EN (5512-2464)	FILE100001285_DE (5512-2465)
ULTRAFLOW® 44 DN15-125	FILE100000272_DK (5512-2589)	FILE100000287_EN (5512-2599)	FILE100000290_DE (5512-2600)
ULTRAFLOW® 54 DN150-300	FILE100000872_DK (5512-875)	FILE100000894_EN (5512-876)	FILE100003581_DE (5512-877)
<b>Data sheet</b>			
ULTRAFLOW® 54 DN15-125	FILE100000563_DA (5810-1546)	FILE100000564_EN (5810-1547)	FILE100000565_DE (5810-1548)
ULTRAFLOW® 44 DN15-125	FILE100001166_DA (5810-1753)	FILE100001165_EN (5810-1751)	FILE100001519_DE (5810-1754)
ULTRAFLOW® 54 DN150-300	FILE100001799_DA (5810-834)	FILE100001801_EN (5810-835)	FILE100001802_DE (5810-836)
<b>Installation guide</b>			
ULTRAFLOW® & MULTICAL® 603	- 5512-2231	FILE100002838_EN 5512-2231	- 5512-2231
ULTRAFLOW® & MULTICAL® 803	- 5512-2408	FILE100002839_EN 5512-2408	- 5512-2408
ULTRAFLOW® 54 DN150-300	5512-886	5512-887	5512-888
Pulse Transmitter/Pulse Divider	5512-1387	5512-1421	5512-1422
Cable Extender Box	5512-2008	5512-2008	5512-2008

Table 22. Technical documentation for ULTRAFLOW®.

Kamstrup A/S  
Industrivej 28, Stilling  
DK-8660 Skanderborg  
TEL: +45 89 93 10 00  
FAX: +45 89 93 10 01  
info@kamstrup.com  
www.kamstrup.com