

SVM Analog input board (FCII)

DATA SHEET

- 1 or 2 channels
- 0/4...20mA
- Resolution 0,01%
- Selectable units
- Analog inputs accessible via M-Bus



Analog current input board 0/4-20mA (FCII)

The analog input board FCII is useful for eg. signal monitoring of analog standard signals such as 0/4-20mA. With this card installed in the F4 calculator, key operating information may be collected from the district heating or cooling substation.

The analog signal is sent via M-Bus to a monitoring system or an AMR system, eg. MCom. The analog input is updated with a 10Hz frequency, and can be read remotely via M-Bus or directly on the LCD.

With the service program "Plug & Play service utility" it is easy to customize the analog board in terms of resolution and measured units, for example pressure, flow or temperature.

The analog input board is also available in a version for 0/2...10 V (FCIU), and a version for Pt100 temperature sensor (FCIP) for the range -50...+210°C.



SVM Analog input board (FCII)

DATA SHEET

Calibration/Configuration

The analog input board FCII is delivered with one or two channels for 0...20mA or 4...20mA. The standard unit for the measured signals is %, with a standard resolution of 0.01%. By using the service program Plug & Play service utility and a service adapter, the option board can easily be reconfigured to the desired resolution and unit. The service adapter and Plug & Play software are both included in the service kit for F4, with ordering number FT-4-adapt-kk.

Power failure

The option board FCII may only be used in 230VAC mains supplied F4 calculators. In the event of a power failure the option board will not work, and the error code "ULOW" will be indicated in the relevant display sequence of the F4 for the option board slot in use. If the meter is read remotely during a power failure, the read value of the analog signals will be 0. When the power is restored, the FCII option board will deliver proper values again within a minute. The inputs of the option board are protected against voltage and current transients.

Technical data

Analog current input board FCII 0/4-20 mA	
Input signal	4 – 20 mA 0 – 20 mA
Input resistance	<500 Ohms
Output over M-Bus	% *
Output on display	%
Resolution	0.01%
Inaccuracy	±0.1 mA
Ambient temp.	5-55°C

*) Can be configured in many different ways.

Card slots

The analog input option board should be installed in card slots B or E. If no extra communication output is required, also slot A may be used.

SVM Analog input board (FCII)

DATA SHEET

Dipswitches

Card slot	BY 1	BY 2	BY 3
A	On		
B		On	
E	On		On
Service	()	On	On

Table 1, Dipswitch settings

Important! Never change the dipswitch setting when power is on.

Installation

NOTE: Cut the power from mains and battery before installation to avoid damaging the meter or the option board.

NOTE: Disconnect any flow sensor connected to the meter, see below for more information.

NOTE: Install only one card at a time.

Recommended installation procedure:

1. Save data by short circuiting the “Save data” circuit.
2. Disconnect the flow sensor by removing at least one of the flow sensor cables.
3. Cut the power by disconnecting the four-pole connectors K2 and K3, cf. Fig.1.
4. Check that DIP switches are correctly set for the selected card slot and install the option board into the slot. The component side shall be turned towards the terminals. Align the chambered end of the board with the right side of the calculator box. Ensure that all pins on the option board are properly connected.
5. Turn power on, reconnect the four-pole connectors: 'K3' (battery) first and then “K2” (RawV).
6. Check that the board is properly installed; the LED “LD3” first blinks and is then turned off.
7. If another board is being installed, repeat steps 3-6.
8. Reconnect the flow sensor.

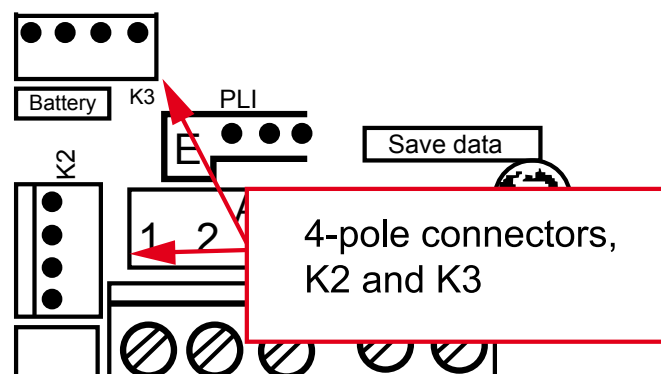

Fig 1, Connection terminal F4

SVM Analog input board (FCII)

DATA SHEET

Connection of analog inputs

Depending on the choice of card slot, use the terminal blocks A, B or E to connect the analog input signals. Also cf. table 2 below.

Card slot	Channel	+	-
A	1	A1	A2
	2	A3	A4
B	1	B3	B4
	2	B1	B2
E	1	E3	E4
	2	E1	E2

Table 2, Card slots and terminal connections

Example 1: The analog board is installed in slot A, and a 4-20mA input signal shall be connected to channel 1:

Use terminal A1 for the positive wire, and terminal A2 for the neutral wire.

Example 2: The analog board is installed in slot B, and a 0-20mA input signal shall be connected to channel 1:

Use terminal B3 for the positive wire, and terminal B4 for the neutral wire.

Example 3: The analog board is installed in slot E, and a 4-20mA input signal shall be connected to channel 2:

Use terminal E1 for the positive wire, and terminal E2 for the neutral wire.

Ordering

Product designation: FCII
Delivery options: ABC
Parameter file: XXXXXX

FCII	A	B	C
One (1) 0/4-20mA input	1		
Two (2) 0/4-20mA inputs	2		
Board delivered separately		1	
Board mounted inside F4		4	
Board for slot A			A
Board for slot B			B
Board for slot E			E

Table 3, Delivery options for FCII

SVM Analog input board (FCII)

DATA SHEET

Ordering

Parameter file

1 input: -C1-420 – 1 input 4-20mA
-C1-020 – 1 input 0-20mA

2 inputs: -C2-420 – 2 inputs 4-20mA
-C2-020 – 2 inputs 0-20mA

Example: Analog current input option board, 4-20mA 2 inputs, mounted in slot B, standard parameter file.

Article number: FCII-24B-C2-420

Example 2: Analog current input option board 4-20mA, 0-20mA, 1 input, delivered separately for slot E, standard parameter file.

Article number: FCII-11E-C1-020

Article number key

Fill out the blanks to acquire the correct article number.

FCII-	A	B	C	-	Parameter file
				-	

Table 3, Article number key