

Data sheet

MULTICAL® 302

All-round heat and cooling meter,
easy to install and easy to use

- On-site configurable as to inlet and outlet
- PN25 metal flow sensor, approved up to 130 °C
- Small pressure loss, all flow sizes below 0.1 bar
- Dynamic range up to 1:1600 from start to saturation flow – 1:250 ($q_i:q_p$)



MID 2014/32/EU



EN 1434

DK-BEK 1178 – 06/11/2014



EN 1434



Contents

Calculator functions	3
Programming and verification	7
Communication	7
Approved meter data	11
Electrical data	12
Mechanical data	13
Material	13
Accuracy	14
Ordering details	15
Dimensional sketches	16
Pressure loss	18
Accessories	19

Description

Application

The minimal dimensions of MULTICAL® 302 allow this compact all-round heat and cooling meter to be installed anywhere. The meter can be turned during installation, in very compact systems too, enabling you to obtain optimal reading of the display at all times.

The robust metal flow sensor that endures temperatures up to 130 °C permanently, is effectively protected against condensation and can be used in both PN16 and PN25 systems.

The flow sensor has been designed with Kamstrup's unique ultrasound technique, which ensures extremely long lifetime – also in magnetite-containing heating systems.

Functionality

MULTICAL® 302 consists of a flow sensor based on ultrasound, an electronic display unit and a Pt500 sensor pair. These components are separately calibrated and subsequently assembled into a heat, cooling or combined heat/cooling meter which must not be separated.

The meter comprises an integral data logger, which saves all relevant registers for the latest 960 hours, 460 days, 24 months and 15 years.

During installation the meter can be configured for installation of flow sensor in either inlet or outlet pipe. Furthermore, unit and resolution as well as date/time and M-Bus address can be selected merely by pressing a button, no special tools needed.

Wired or Wireless M-Bus

MULTICAL® 302 is available with factory mounted cable for wired M-Bus or with Wireless M-Bus in either mode C1 or T1 OMS according to EN 13757.

The M-Bus communication is galvanically separated and comprises auto-select 300/2400 Baud, primary/secondary addressing and collision detection. The current consumption of the master is lower than 1 unit load, and separate registers for heat and cooling energy are read.

The wireless data communication, Wireless M-Bus, follows the European standard EN 13757, and the data telegram is configurable for either mode C1, T1 BSI or T1 OMS.

Data communication, including 128 bit AES encryption.

Calculator functions

Energy calculation

MULTICAL® 302 calculates energy on the basis of the formula stated in EN 1434-1:2015, which uses the international temperature scale issued in 1990 (ITS-90) and the pressure definition of 16 bar.

In a simplified form the energy calculation can be expressed as:
Energy = $V \times \Delta\Theta \times k$.

V is the added volume of water

$\Delta\Theta$ is the measured temperature difference

k is the heat coefficient of the water

The calculator always calculates energy in [Wh], which are subsequently converted into the selected measuring unit.



E [Wh] =	$V \times \Delta\Theta \times k \times 1,000$
E [kWh] =	$E \text{ [Wh]} / 1,000$
E [MWh] =	$E \text{ [Wh]} / 1,000,000$
E [GJ] =	$E \text{ [Wh]} / 277,780$
E [Gcal] =	$E \text{ [Wh]} / 1,163,100$

Application types

MULTICAL® 302 operates with 4 different energy formulas, E1, E3, E8 and E9, which are all calculated parallel with each integration no matter the configuration of the meter.

The four energy types are calculated as follows:

$E1 = V1(T1 - T2)k$	Heat energy (V1 in inlet or outlet)
$E3 = V1(T2 - T1)k$	Cooling energy (V1 in inlet or outlet)
$E8 = m^3 \times T1$	Average temperature (inlet)
$E9 = m^3 \times T2$	Average temperature (outlet)

This enables MULTICAL® 302 to calculate heat and cooling energy in most applications. All energy types are data logged and can be displayed dependent on configuration.

Flow measurement

MULTICAL® 302 calculates current water flow every four seconds or every two seconds determined by configuration.



Power measurement

MULTICAL® 302 calculates current power based on current water flow and the temperature difference measured at the latest integration.

Current power is updated in the display every 32 or every 8 seconds dependent on configuration.



Calculator functions

Maximum flow and power

MULTICAL® 302 registers maximum flow and maximum power values on a yearly as well as a monthly basis. The registrations can be read via data communication or from the display in "Tech loop".

All maximum values are calculated as the highest average of a number of current flow or power measurements. The average period used for all calculations is selected within the interval of 1...1440 min.



Temperature measurement

Inlet and outlet temperatures are measured by means of an accurately matched Pt500 sensor set in two-wire version.

The measuring circuit comprises a high-resolution analogue-to-digital converter with a temperature range of 0.00 °C to 155.00 °C.

In addition to current temperatures for the energy calculation yearly and monthly average temperatures can be displayed.

Display functions

MULTICAL® 302 is fitted with an easily readable LC-display comprising 8 digits, measuring units and an information field. Energy and volume readings use 7 digits plus corresponding measuring units, whereas 8 digits are used to display e.g. the meter number.



Basically accumulated energy is displayed. Activating the push-button the display immediately switches to other readings. The display automatically returns to energy reading four minutes after the latest activation of the push-button, and after four more minutes without activation the display switches off in order to save current.

The meter uses four different loops for four different user situations:

- User loop
- Tech loop
- Setup loop
- Test loop

Only one loop can be displayed at a time.



Calculator functions

User loop

User loop is the primary loop, which is accessible when the meter has been installed and is in normal operation. The loop includes legal and most used readings. User loop is primarily intended for the user of the meter.



1-USER

Tech loop

Tech loop is primarily for technicians and other persons who are interested in viewing further data. Tech loop displays all legal registers, other important registers as well as logged data.



2-TECH

Setup loop

Setup loop comprises everything that can be changed in the meter. In Setup loop selected configurations in the meter can be changed:

- Customer No.
- Date
- Time
- Target date
- Flow sensor installation (inlet/outlet)
- Energy unit/resolution
- Primary M-Bus address
- Max average peak time
- Heat/cooling-switching
- Radio (on/off)



3-SETUP

Test loop

Test loop is intended for laboratories and others who are to calibrate or verify the meter.



4-TEST

Calculator functions

Info codes

MULTICAL® 302 constantly monitors a number of important functions. If a serious error occurs in measuring system or installation, a flashing "INFO" will appear in the display. The "INFO"-field keeps flashing as long as the error exists no matter which reading you choose. The "INFO"-field automatically disappears when the reason for the error has been removed.

An info-event counter shows how many times the information code has been changed.

The info logger saves the latest 50 changes, of which the latest 36 changes can be displayed.

Info code	Description	Response time
0	No irregularities	-
1	Supply voltage has been interrupted	-
4	Temperature sensor T2 outside measuring range	< 32 sec.
8	Temperature sensor T1 outside measuring range	< 32 sec.
32	Temperature difference has wrong polarity	< 32 sec. and 0.05 m ³
128	Supply voltage too low	< 10 sec.
16	Flow sensor with weak signal or air	< 32 sec.
2	Flow sensor with wrong flow direction	< 32 sec.

Data loggers

MULTICAL® 302 has a permanent memory (EEPROM), in which the values of many different data loggers are saved.

MULTICAL® 302 saves the results from the annual and monthly logs based on the target dates. It is possible to create two target dates for biannual reading.

The meter includes the following data loggers:

Data logging interval	Data logging depth	Data logged value
Yearly logger	15 years	Counter register
Monthly logger	24 months	Counter register
Daily logger	460 days	Counter register
Hourly logger	960 hours	Counter register
Info logger	50 events (36 events can be displayed)	Info code and date
Config. logger	25 config. changes	New config. and date

Power supply

MULTICAL® 302 is available with 1 or 2 built-in A-cell batteries,

- 1 x A-cell lithium battery is sufficient to power MULTICAL® 302 for an operating period of 6-8 years.
- 2 x A-cell lithium battery must be selected for MULTICAL® 302 if 12-16 years' battery lifetime is required.

Programming and verification

METERTOOL for MULTICAL® 302 is Windows-based software that includes facilities for programming the calculator. Furthermore, it is possible to test and verify the calculator.

Please contact Kamstrup A/S for further information.



Communication

MULTICAL® 302 offers two different forms of communication, namely wired M-Bus or Wireless M-Bus.

Wired M-Bus

If the meter is supplied with built-in wired M-Bus, M-Bus protocol according to EN 13757-3:2013 is used.

Connection to the M-Bus master is established via the fixed 2-wire cable. Connection is independent of polarity and the M-Bus interface is galvanically separated from the rest of the meter.

Communication speed with automatic baud rate detection is 300 or 2400 Baud. Both primary and secondary addressing are supported.

Current consumption: 1 unit load (1.5 mA).

The following data can be read via M-Bus:

M-Bus data header	Current data	Target data*	Meter data
M-Bus ID	Heat energy E1	Heat energy E1	Serial number
Producer ID	Cooling energy E3	Cooling energy E3	Customer number 1
Version	Energy m ³ x T1= E8	Energy m ³ x T1= E8	Customer number 2
Device type	Energy m ³ x T2 = E9	Energy m ³ x T2 = E9	Config. number 1
Access counter	Volume V1	Volume V1	Config. number 2
Status	Hour counter	Max. power	Meter type
Configuration	Error hour counter	Max. flow	SW revision
	T1	Target date	
	T2		
	T1-T2		
	Current power		
	Max. power this month*		
	Actual flow		
	Max. flow this month*		
	Info code		
	Date/time		

* Monthly data is transmitted by default. Change to yearly data possible by means of an M-Bus command. For further details we refer to Technical description on M-Bus for MULTICAL® 302.

Communication

Wireless M-Bus

If the meter has built-in wireless M-Bus, you can choose between Mode C1, Mode T1 BSI or Mode T1 OMS.

Mode C1 is used in connection with Kamstrup’s reading systems and for drive-by meter reading in general.

Mode T1 BSI/T1 OMS is used in connection with OMS-based stationary networks. The meter has an internal antenna.

Mode C1

Protocol according to EN 13757-4:2013. Transmission interval: 16 sec. Individual 128 bit AES encryption.

Data packets Mode C1

Heat meter HH = 01 or 02	Heat meter HH = 11 or 12	Cooling meter	Heat/cooling meter
Header Producer ID Serial number Version Status Hour counter	Header Producer ID Serial number Version Status Hour counter	Header Producer ID Serial number Version Status Hour counter	Header Producer ID Serial number Version Status Hour counter
Current data Heat energy E1 Volume V1 Power Info code	Current data Heat energy E1 Info code	Current data Cooling energy E3 Volume V1 Power Info code	Current data Heat energy E1 Cooling energy E3 Power Info code
Target data* Date Heat energy E1 last month or Heat energy E1 last year	Target data* Date Heat energy E1 Volume V1 Energy m ³ *T1= E8 Energy m ³ *T2= E9 Last month or last year*	Target data* Date Cooling energy E3 last month or Cooling energy E3 last year	Target data* Date Heat energy E1 last month Cooling energy E3 last month or Heat energy E1 last year Cooling energy E3 last year

* Monthly or yearly data depends on HH configuration.
For further details we refer to Technical description for MULTICAL® 302.

Communication

Mode T1 BSI

Protocol according to EN13757-4:2013 and OMS Specification Volume 2 issue 4, security profile B.

Transmission interval 16 seconds. Individual 128 bit AES encryption.

Data packets Mode T1 BSI

Heat meter	Cooling meter	Heat/cooling meter
Header Device type Producer ID Serial number Version Status	Header Device type Producer ID Serial number Version Status	Header Device type Producer ID Serial number Version Status
Current data Heat energy E1 Volume V1 Info bits Flow T1 T2 Power Date	Current data Cooling energy E3 Volume V1 Info bits Flow T1 T2 Power Date	Current data Heat energy E1 Volume V1 Info bits Flow T1 T2 Power Date
Target data* Heat energy E1 last month Volume V1 last month Max flow V1 last month or Heat energy E1 last year Volume V1 last year Max flow V1 last year	Target data* Cooling energy E3 last month Volume V1 last month Max flow V1 last month or Cooling energy E3 last year Volume V1 last year Max flow V1 last year	Target data* Heat energy E1 last month Volume V1 last month Max flow V1 last month or Heat energy E1 last year Volume V1 last year Max flow V1 last year

* Monthly or yearly data depends on HH configuration.
 For further details we refer to Technical description for MULTICAL® 302.

Communication

Mode T1 OMS

Protocol according to EN13757-4:2013 and OMS Specification Volume 2 issue 3.0.1.
Transmission interval 15 min. Individual 128 bit AES encryption.

Data packets Mode T1 OMS

Heat meter	Cooling meter	Heat/cooling meter
Header Device type Producer ID Serial number Version Status	Header Device type Producer ID Serial number Version Status	Header Device type Producer ID Serial number Version Status
Current data Heat energy E1 Volume V1 Power Flow T1 T2 Hour counter Date Info code	Current data Cooling energy E3 Volume V1 Power Flow T1 T2 Hour counter Date Info code	Current data Heat energy E1 Cooling energy E3 Volume V1 Power Flow T1 T2 Hour counter Date Info code
Target data* Heat energy E1 last month Volume V1 last month or Heat energy E1 last year Volume V1 last year Target date	Target data* Cooling energy E3 last month Volume V1 last month or Cooling energy E3 last year Volume V1 last year Target date	Target data* Heat energy E1 last month Cooling energy E3 last month Volume V1 last month or Heat energy E1 last year Cooling energy E3 last year Volume V1 last year Target date

* Monthly or yearly data depends on HH configuration.
For further details we refer to Technical description for MULTICAL® 302.

Approved meter data

EU directives	Measuring Instruments Directive Low Voltage Directive Electromagnetic Compatibility Directive Pressurised Equipment Directive RoHS Directive
Standards	EN 1434:2015
Heat meter	Approval: DK-0200-MI004-031 Temperature range θ : 2 °C...150 °C Differential range $\Delta\theta$: 3 K...130 K
Cooling meter	Approval: TS27.02.001 Temperature range θ : 2 °C...150 °C Differential range $\Delta\theta$: 3 K...85 K Approval: PTB TR K7.2 (22.72/13.04) Temperature range θ : 2 °C...150 °C Differential range $\Delta\theta$: 3 K...85 K
Accuracy	Calculator: $E_c = \pm [0.5 + \Delta\theta_{\min}/\Delta\theta]$ % Flow sensor: $E_q = \pm [2 + 0.02 q_r/q_i]$, but not exceeding ± 5 %
Dynamic range $q_i:q_p$	1:250 and 1:100
Temperature sensors	Type 302-T: Pt500 – EN 60 751, 2-wire, hard-wired connection
EN 1434 designation	Accuracy class 2 and 3 / Environmental class A
MID designation	Mechanical environment: Class M1 and M2 Electromagnetic environment: Class E1 5...55 °C non-condensing, closed location (indoor installation)

The stated minimum temperatures are only related to the type approval. The meter has no cutoff for low temperature and thus measures down to 0.01 °C and 0.01 K.

Type number	Nom. flow q_p [m ³ /h]	Max flow q_s [m ³ /h]	Min. flow cutoff [l/h]	Saturation flow [m ³ /h]	Pressure loss $\Delta p @ q_p$ [bar]	Threaded connection on meter	Length [mm]
302Txxxxx10xxx	0.6	1.2	3	3.0	0.03	G½B	110
302Txxxxx11xxx	0.6	1.2	3	3.0	0.03	G½B	130
302Txxxxx12xxx	0.6	1.2	3	3.0	0.03	G½B	165
302Txxxxx40xxx	1.5	3.0	3	5.0	0.09	G¾B	110
302Txxxxx41xxx	1.5	3.0	3	5.0	0.09	G¾B	130
302Txxxxx42xxx	1.5	3.0	3	5.0	0.09	G¾B	165
302Txxxxx70xxx	1.5	3.0	3	5.0	0.09	G1B	130
302Txxxxx71xxx	1.5	3.0	3	5.0	0.09	G1B	190
302Txxxxx72xxx	1.5	3.0	3	5.0	0.09	G1B	220
302TxxxxxA0xxx	2.5	5.0	5	7.0	0.09	G1B	130
302TxxxxxA1xxx	2.5	5.0	5	7.0	0.09	G1B	190
302TxxxxxA2xxx	2,5	5,0	5	7,0	0,09	G1B	220

Electrical data

Calculator data

Typical accuracy	Calculator: $E_c = \pm (0,15 + 2/\Delta\Theta) \%$ Sensor pair: $E_r = \pm (0,4 + 4/\Delta\Theta) \%$
Display	LCD – 7 (8) digits with digit height 6 mm
Resolution	9999.999 – 99999.99 – 999999.9 – 9999999
Energy units	MWh – kWh – GJ
Data logger (EEPROM)	Interval log: 960 hours, 460 days, 24 months, 15 years Event log: 50 Info events, 25 Configuration events
Clock/calendar	Clock, calendar, leap year compensation, target date
Data communication	KMP protocol with CRC16 used for optical communication
M-Bus	Protocol according to EN 13757-3:2013, 300 and 2400 Baud communication speed with automatic baud rate detection. Current consumption: 1 unit load (1.5 mA). Fixed 2-wire cable. Polarity independent.
wM-Bus	Mode C1 protocol according to EN 13757-4:2013. Individual 128 bit AES encryption. Transmission interval: 16 sec. Transmission frequency: 868.95 MHz Mode T1 BSI protokol iht. EN13757-4:2013 og OMS Specification Volume 2 issue 4. Individuel 128 bit AES-kryptering, security profile B. Transmissionsinterval: 16 sek. Transmissionsfrekvens: 868,95 MHz Mode T1 OMS protokol iht. EN13757-4:2013 og OMS Specification Volume 2 issue 3. Individuel 128 bit AES-kryptering, security profile A. Transmissionsinterval: 15 min. Transmissionsfrekvens: 868,95 MHz
Power of temperature sensors	< 0.5 μ W RMS
Supply voltage	3.6 VDC \pm 0.1 VDC
EMC data	Fulfills EN 1434 class A (MID class E1)

Temperature measurement				
2-Wire Pt500	T1 Inlet temperature	T2 Outlet temperature	$\Delta\Theta$ (T1-T2) Heat metering	$\Delta\Theta$ (T2-T1) Cooling metering
Measuring range	0.00...155.00 °C	0.00...155.00 °C	0.01...155.00 K	0.01...155.00 K

Battery	3.65 VDC, 1 x A-cell lithium	3.65 VDC, 2 x A-cell lithium
Battery life*	8 years @ $t_{BAT} < 30$ °C 6 years @ $t_{BAT} < 45$ °C	16 år @ $t_{BAT} < 30$ °C 12 år @ $t_{BAT} < 45$ °C
	NB: With Mode T1 BSI, the above battery lifetime is halved, eg. to 8 years with 2 x A cell lithium ($t_{BAT} < 30$ °C)	
Lithium content	0.96 g	2 x 0.96 g
Transport class	Not subject to dangerous goods regulations	
Outside the USA	Non-restricted to transport/Non-assigned to Class 9	
Within the USA	Belonging to the category of "small primary lithium cells"	

* The battery life is reduced by use of frequent data communication and high ambient temperature.

Mechanical data

Environmental class Fulfils EN 1434 class A and MID class E1and M2

	Protection class	Ambient temperature	Environmental class	
Calculator	IP65	5...55 °C	Non-condensing	Indoors (closed position)
Flow sensor and temp. sensor pair	IP68		Condensing	

Medium temperatures

Heat meters 302-T 2...130 °C

Cooling meters 302-T 2...130 °C

Heat/cooling meters 302-T 2...130 °C

Cooling meters 302-C 2...50 °C

Medium in flow sensor Water

Storage temperature -25...60 °C (drained flow sensor)

Pressure stage (with thread) PN16 and PN25

Weight From 0.7 to 1.1 kg depending on flow meter size and extension piece

Flow sensor cable 1.2 m (non demountable cable)

Temperature sensor cables 1.5 m (non demountable cables)

At medium temperatures below the ambient temperature the calculator must be wall mounted in order to prevent condensation.

At medium temperatures above 90 ° the calculator must be wall mounted in order to prevent too high temperature, especially in relation to display and battery lifetime.

Material

Wetted parts	Flow sensor case	Hot dezincification proof brass (CW 602N)
	Diaphragms	Stainless steel, W.no. 1.4404
	O-rings	EPDM
	Measuring tube	Thermoplastic, PES
	Reflectors	Thermoplastic, PES 30 % GF and stainless steel, W.no. 1.4306
Flow sensor cover	Thermoplastic, PC 20 % GF	
Wall bracket	Thermoplastic, PC 20 % GF	
Calculator case	Top	Thermoplastic, PC 10 % GF
	Base	Thermoplastic, ABS with TPE gaskets (thermoplastic elastomer)
Cables	Flow sensor	Silicone cable with inner Teflon insulation
	Temperature	Silicone cable with inner Teflon insulation
	M-Bus	Silicone cable with inner Teflon insulation

Accuracy

Heat meter components	MPE according to EN 1434-1	MULTICAL® 302, typical accuracy
Flow sensor	$E_f = \pm [2 + 0.02 q_p/q] \%$	$E_f = \pm [1 + 0.01 q_p/q] \%$
Calculator	$E_c = \pm [0.5 + \Delta\Theta_{\min}/\Delta\Theta] \%$	$E_c = \pm [0.15 + 2/\Delta\Theta] \%$
Sensor pair	$E_t = \pm [0.5 + 3 \Delta\Theta_{\min}/\Delta\Theta] \%$	$E_t = \pm [0.4 + 4/\Delta\Theta] \%$

MULTICAL® 302 q_p 1,5 m³/h @ $\Delta\Theta$ 30K

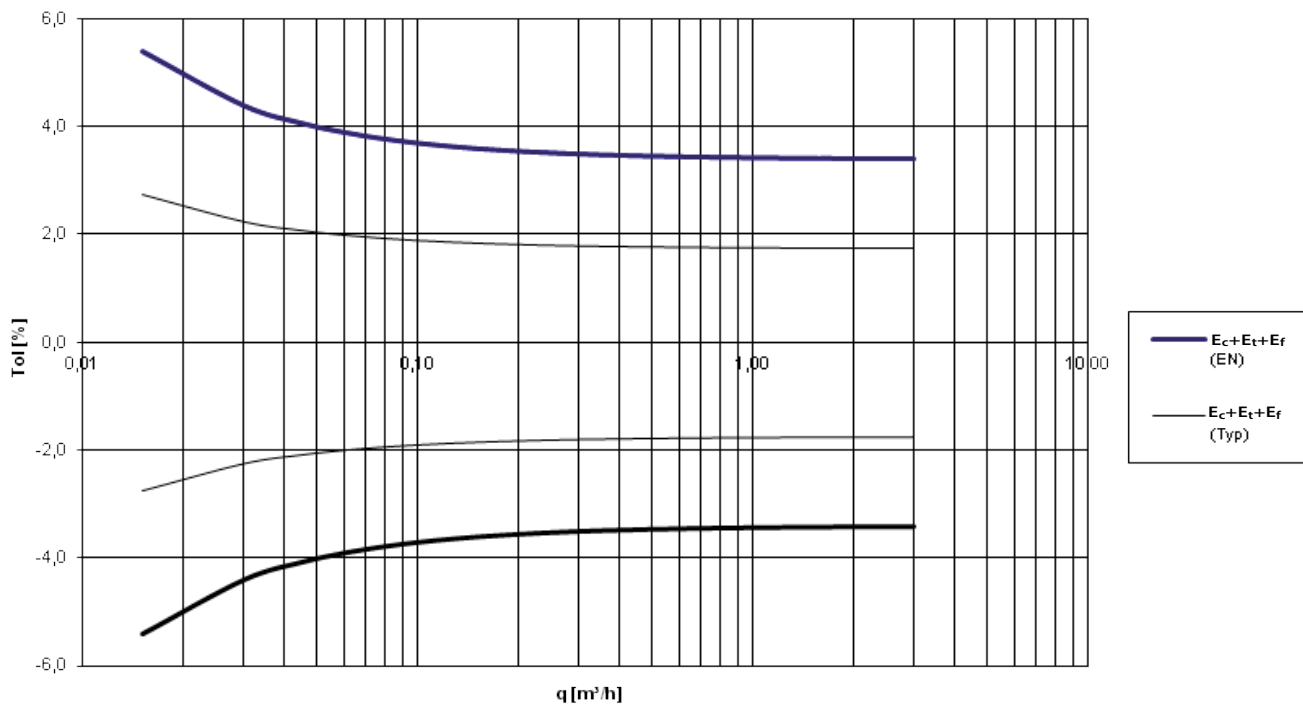

Ordering details

MULTICAL® 302		Type 302	<input type="checkbox"/>	<input type="checkbox"/>	<input type="checkbox"/>	<input type="checkbox"/>	<input type="checkbox"/>	<input type="checkbox"/>	<input type="checkbox"/>
Basic version									
Pt500 heat and heat/cooling meter		T							
Pt500 cooling meter		C							
Communication									
No communication								00	
M-Bus (comes with 1.5 m factory mounted cable)								20	
M-Bus (comes with 2.0 m factory mounted cable)								21	
Wireless M-Bus, 868 MHz (configurable mode C1, T1 BSI or T1 OMS)								30	
Supply									
6-8 years battery, Normal Response meter									1
12-16 years battery, Normal Response meter									2
6-8 years battery, Quick Response meter									3
Temperature sensors									
Pt500, ø 5.2 mm temperature sensors, cable length 1.5 m, with composite union nuts									Q9
Pt500, ø 5.2 mm temperature sensors, cable length 1.5 m, with brass union nuts									QF
Flow sensor									
q_p [m³/h]	Connection	Length [mm]							
0,6	G¾B (R½) DN 15	110							10
								With extension to 130 mm	11
								With extension to 165 mm	12
1,5	G¾B (R½) DN 15	110							40
								With extension to 130 mm	41
								With extension to 165 mm	42
1,5	G1B (R¾) DN 20	130							70
								With extension to 190 mm	71
								With extension to 220 mm	72
2,5	G1B (R¾) DN 20	130							A0
								With extension to 190 mm	A1
								With extension to 220 mm	A2
Meter type									
Heat meter (MID module B+D)								θ _{nc} = OFF	2
Heat meter/cooling meter (MID module B+D & TS27.02+DK268)								θ _{nc} = OFF	3
Heat meter (National approvals)								θ _{nc} = OFF	4
Cooling meter (TS27.02+DK268)								θ _{nc} = OFF	5
Heat/cooling meter								θ _{nc} = ON	6
Country code (language on label etc.) Letters can also be used.									XX

Dimensional sketches

All measurements in [mm]

Calculator

MULTICAL® 302 with calculator mounted on flow sensor

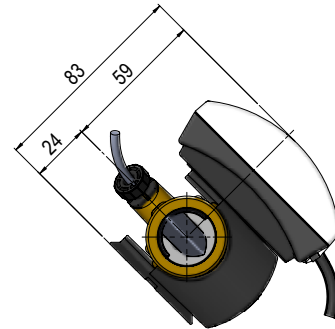
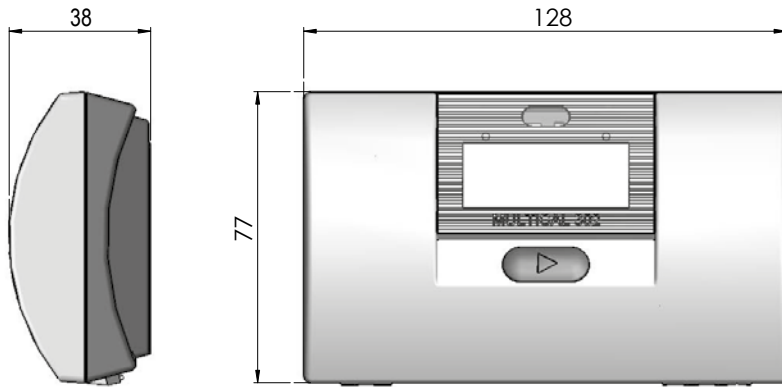

Wall-mounted calculator

Wall fitting for calculator

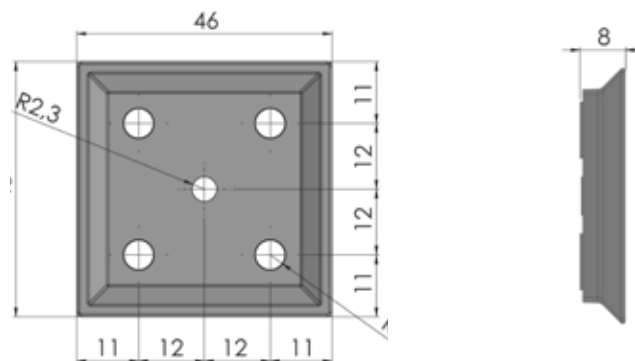
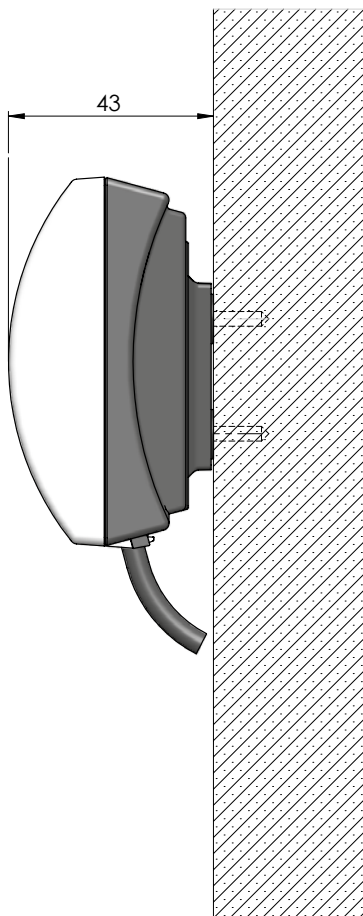

Temperature sensor

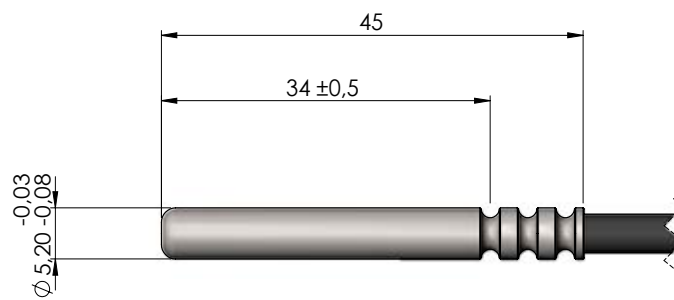

Dimensionel sketches

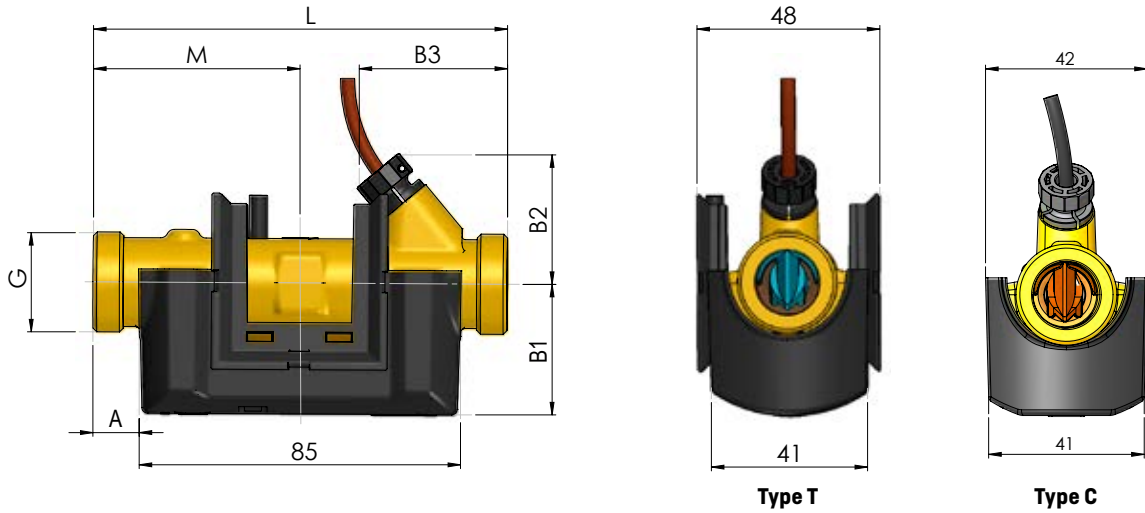

Thread	L [mm]	A [mm]	B1 [mm]	B2 [mm]	B3 [mm]	Approx. weight [kg] *
G $\frac{3}{4}$ B (R $\frac{1}{2}$)	110	12	35	35	40	0.7
G1B (R $\frac{3}{4}$)	130	22	38	38	50	0.8

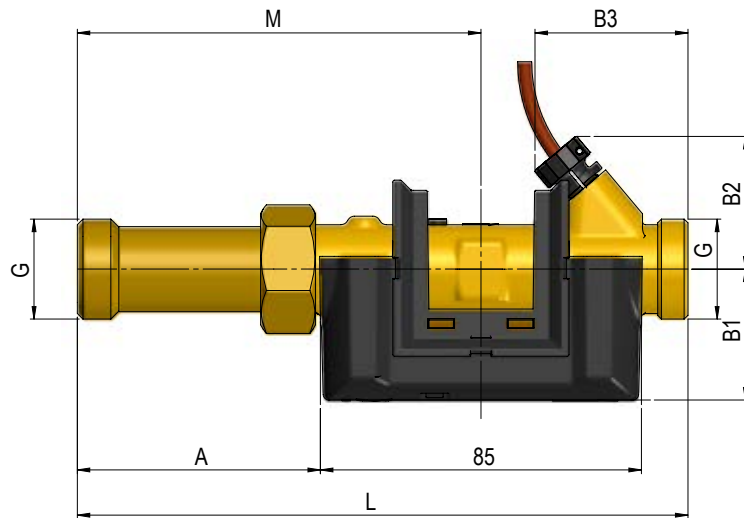

Thread	L [mm]	M [mm]	A [mm]	B1 [mm]	B2 [mm]	B3 [mm]	Approx. weight [kg] *
G $\frac{3}{4}$ B (R $\frac{1}{2}$)	130	73	30	35	35	40	0.8
G $\frac{3}{4}$ B (R $\frac{1}{2}$)	165	109	66	35	35	40	0.8
G1B (R $\frac{3}{4}$)	190	124	81	38	38	50	1.0
G1B (R $\frac{3}{4}$)	220	154	111	38	38	50	1.1

* The weight indication comprises the whole meter incl. flow sensor, calculator, sensor pair and 2 x A batteries. Enclosed accessories such as couplings, nipples and sensor pockets, if any, as well as packing are not included in the weight indication.

Pressure loss

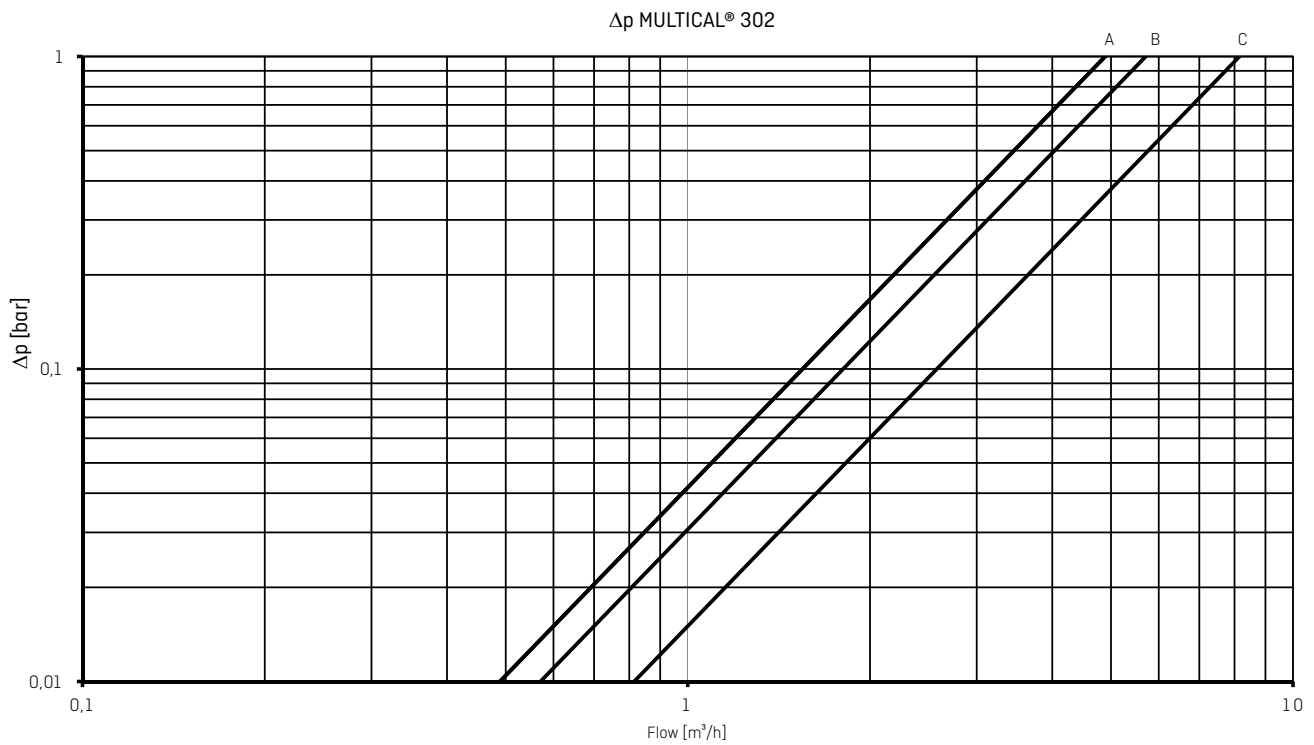

Graph	q_p [m³/h]	Size	Nom. diameter [mm]	$\Delta p@q_p$ [bar]	k_v	Q@0.25 bar [m³/h]
A	0.6	G½B x 110 mm	DN15	0.02	4.89	2.4
A	1.5	G½B x 110 mm	DN15	0.09	4.89	2.4
B	1.5	G1 x 130 mm	DN 20	0.07	5.71	2.9
C	2.5	G1 x 130 mm	DN 20	0.09	8.15	4.1

Accessories

Type number	Description
3026-655.A	Wall fitting (LEXAN 3412R black)
3026-909	Holder for optical reading head
3130-262	Blind plug for temperature sensor in flow part (copper alloy brass, CW614N)
4000-010	Union nut set for temperature sensors (copper-alloyed brass, CW617N)
6566-546	R½ x M10 nipple (copper alloyed brass, CW614N)
6566-547	R¾ x M10 nipple (copper alloyed brass, CW614N)
6557-302	G½ sensor pocket 35 mm (copper alloy brass, CW614N)
6699-099	Infra-red optical reading head w/USB plug
6699-304	Infra-red optical reading head for NOWA
6699-016	Kamstrup NOWA KAS software
6699-724	METERTOOL HCW
6699-725	LogView HCW

Note: Ball valves with M10x1 socket (type: 6556-474, -475 and -476) are not suitable for sensors with O-ring seal as they are intended for flat gaskets.

Accessories

Couplings (PN16)

Order code	Size	Nipple	Coupling
6561-323	DN15	R½	G¾
6561-324	DN20	R¾	G1

Material: copper-alloyed brass, CW617N (fitting). Copper-alloyed brass, CW602N (union nut)

Gaskets for couplings

Order code	Size (coupling)
3130-126	G¾
3130-127	G1

Extension pieces

Order code	Description	Length [mm]	Total length [mm]
6556-505	Extension piece G¾B	20	130
6556-506	Extension piece G¾B	55	165
6556-507	Extension piece G1B	60	190
6556-508	Extension piece G1B	90	220

Material: copper-alloyed brass (CW614N)

For further information on MULTICAL® 302, please see the technical description [5512-1334] which is available on products.kamstrup.com.

Local Sales & Support:

Kamstrup Middle East FZC

Dubai Outsource City, Building 8
Office 205 P.O. BOX 345040
Dubai, United Arab Emirates
T: +971 4 453 7337
dubai@kamstrup.com
kamstrup.com

Headquarters:

Kamstrup A/S

Industrivej 28, Stilling
DK-8660 Skanderborg
T: +45 89 93 10 00
F: +45 89 93 10 01
info@kamstrup.com
kamstrup.com