

MULTICAL® TYPE 66-CDE

Technical Description

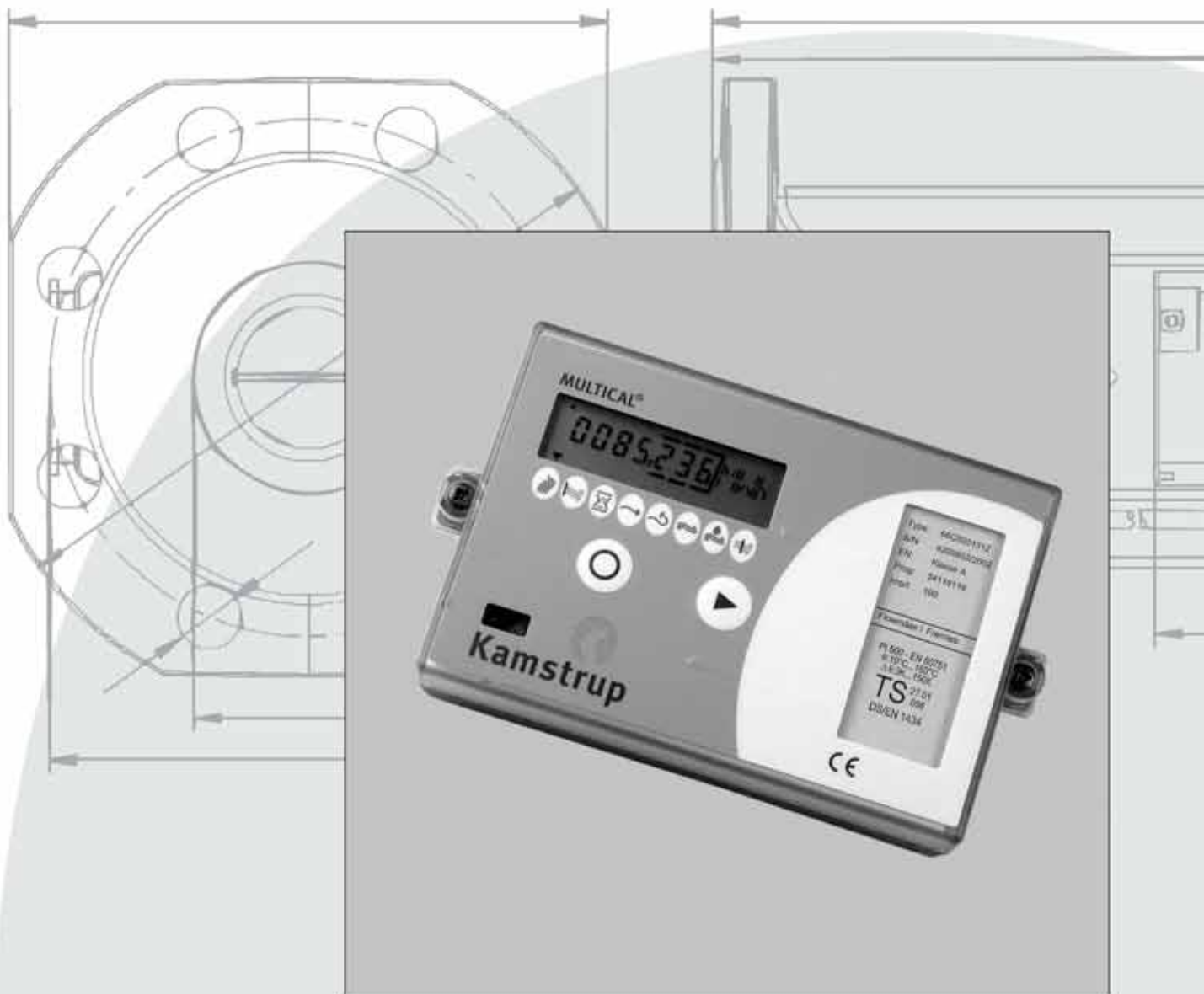

Kamstrup

Kamstrup A/S
Industrivej 28, Stilling,
DK-8660 Skanderborg
TEL: +45 89 93 10 00,
FAX: +45 89 93 10 01
info@kamstrup.com
www.kamstrup.com

Table of contents

Preface	5	7. Programming via METERTOOL	43
1. General description	7	7.1 PC and printer requirements	43
1.1 66-C, Energy meter	7	7.2 Installation of software	43
1.2 66-D, Energy meter for open systems	8	7.3 Connecting MULTICAL® Type 66-CDE to PC	44
1.3 66-E, Energy meter for closed systems	8	7.4 Reading of MULTICAL® Type 66-CDE	44
1.4 Display functions	9	7.5 Programming	44
1.5 Temperature measuring	10	7.6 File	45
1.6 Flow measuring	10	7.7 Utility	45
1.6.1 Pulse transmitter	11	7.8 Options	45
1.7 Energy calculation	12	7.9 Windows	45
1.8 Info codes	14	7.10 Help	46
1.9 Reset functions	15	7.11 Supplementary programs	46
2. Number system	16	8. Verification via METERTOOL	47
2.1 Type number	17	8.1 Function	47
2.2 Prog., A-B-CCC-CCC	18	8.2 Verification data	47
2.3 CONFIG, DD-E-FF-GG-M-N	22	8.3 Verification	48
2.4 ›DATA‹ for configuration	29	8.4 Maintenance	48
2.5 Valve specification	29	8.5 Certificate	49
3. Voltage supply	30	9. Dimensional drawings	50
4. Data communication	33	9.1 File	50
4.1 66-B compatible data	34	9.2 Command	50
4.2 Specific data loggers for 66-CDE	35	9.3 Option	50
4.3 Specific data string for 66-CDE	36	9.4 View Chart	50
4.4 EN 61 107, Optical data read-out	36	9.5 Window	50
5. Plug-in modules	37	9.6 Help	50
5.1 Data/pulse inputs	38	10. Alphabetical register	51
5.2 Data/pulse outputs	38	11. Dimensional drawings	53
5.3 Telephone modem/pulse inputs	39	12. Temperature sensors	54
5.4 M-Bus, EN 1434/pulse inputs	39	12.1 EN 60751 table for Pt500 sensors	54
5.5 Telephone modem/pulse outputs	39	12.2 Sensor types	55
5.6 4...20 mA inputs/Data/pulse inputs	39	12.3 Pt500 pocket sensors	55
5.7 LonWorks, FTT-10A/pulse inputs	40	12.4 Sensor cables	56
5.8 M-Bus – EN1434/Pulse outputs	40	13. Trouble shooting	57
5.9 Data cables	40	14. Approvals	58
5.10 Radio/Pulse inputs/outputs	41	14.1 Type approval	58
5.11 Data cables	41	14.2 CE-Declaration	58
6. Printing logged data	42	14.3 Leakage detection	58
		15. Disposing of energy meters	59
		16. Documents	60

Preface

MULTICAL® type 66-CDE is an energy meter with many applications. In addition to being an accurate and reliable heat meter for battery or mains operation 66-CDE can also be used for:

- Cooling metering in water-based systems
- Bifunctional metering in heating/cooling systems
- Leak detection in heating/cooling installations
- Power and flow limiter with valve control
- Datalogger
- Energy metering in open systems

Flexibility has been an essential parameter when designing MULTICAL® Type 66-CDE. Programmable functions and plug-in modules ensure optimum use in a number of applications. In addition, this construction makes it possible to retrofit the modules in meters that have already been installed, subsequently updating via the METERTOOL PC-program.

This technical description has been written with a view to giving works managers, meter technicians, consulting engineers and distributors, in depth information pertaining to all MULTICAL® Type 66-CDE functions, so that these can be utilized in full. Furthermore, the description will be a helpful tool for laboratories performing tests and verifications.

During the preparation of this technical description we have focused on emphasizing the functional differences between MULTICAL® III, Type 66-B and MULTICAL® Type 66-CDE to ensure established users of MULTICAL® III, Type 66-B a safe product conversion. Under each relevant paragraph involving this product conversion, comments marked by “66-B ⇒ 66-CDE” will appear.

1. General description

MULTICAL® Type 66-CDE is a name which describes three types of MULTICAL®: 66-C, 66-D and 66-E. The type designation indicates which application the individual type is suited to. The most important characteristics of each type are described in the following paragraphs.

Common functions, such as data reading, plug-in modules and datalogging are described in separate paragraphs:

4. Data communication
5. Plug-in modules
6. Datalogging

1.1 66-C, Energy meter

MULTICAL® Type 66-C is used for metering, calculating and registering thermal heat and cooling energy in all plants using water as an energy leading medium. MULTICAL® Type 66-C can perform a number of functions relevant to heating and cooling plants:

Heat metering

The calculation of thermal energy is made on the basis of volume based integrations. The typical integration interval is 10 litres at a flow meter of q_p 1,5 m³/h. The calculations are made more frequently as the water flow increases. The water volume is then multiplied by the actual cooling and the appropriate correction factor, according to EN 1434, this gives the real energy. The part of the energy increase which cannot be shown on the display due to the screen resolution will be stored in the memory and added to the next integration.

Cooling metering

Metering of cooling energy is made in the same way as described above. In both instances the temperature sensor marked with red is placed in the flow pipe and temperature sensor marked with blue in the return. In connection with cooling metering a negative differential temperature will appear by means of which MULTICAL® Type 66-C will register the cooling energy in a separate register, provided the flow temperature is less than the programmed limit of e.g. 25°C. (see the graph below). Cooling energy, cooling effect and negative differential temperature are all marked with (-) minus in the display.

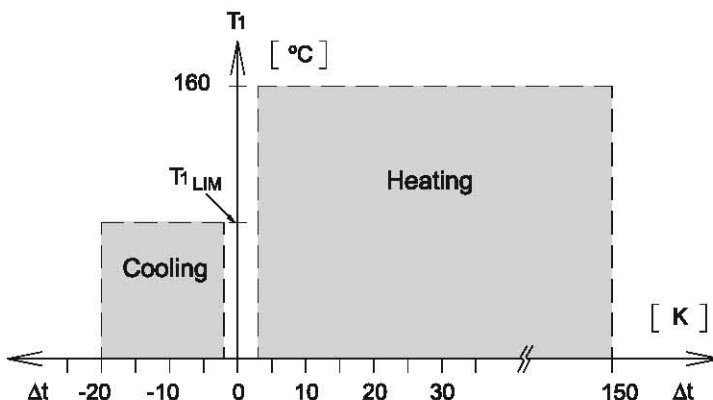

Bifunctional energy metering

In plants which circulate heat during the winter season and are used for cooling during the summer season, MULTICAL® Type 66-C can be used for bifunctional energy metering. Thermal heat and cooling energy are measured in separate registers, which make differentiated user billing possible.

See paragraph 1.7 *Calculation of energy for further information on calculation* and paragraph 2.3.1.1 *»DD« Display readings for 66-C* for information on possible readings with this meter type.

Leak detection

When two ULTRAFLOW® flow meters are connected to MULTICAL® Type 66-C flow meters, flow and return, can make a constant comparison of the mass (temperature adjusted volume) which passes in and out of the installation. When exceeding a programmed limit an alarm message can be sent e.g. through a built-in modem module.

Leak detection is divided into two functions;

- At 24-hour intervals, relatively small mass differences of approx. 9 kg/hour can be monitored.
- Differences larger than 20% of the flow meters' measuring area q_p will release an alarm after 90 seconds.

In addition, leakages can also be monitored in cold tap water. When input A, by means of a water meter with pulse outlet, is used for accumulating the cold-water consumption, a monitoring function can be activated e.g. that the consumption for the past 1 hour/24 hours has been zero. In this way dripping taps and defective toilet systems can be detected after max. 24 hours. The sensitivity can be configured for a period of time, or permanently via a PC or a hand-held terminal.

Alarm for leaks in the cold-water system will also be activated e.g. via a built-in modem module.

See paragraph 2.3.4 *Configuration of leakage limits* for further information.

PQ-controls

Using built-in regulating devices MULTICAL® Type 66-C can control a 3-point motor-operated valve, through a Solid State Relay, with a view to implementing power or flow limitation.

In applications where max. heat power or water flow must be limited, the customer will obtain an extremely simple system, as the installation is insignificant and power/flow limits can be set via PC or hand-held terminal.

See paragraph 2.3.2.1 *Tariff types* for further information.

1.2 66-D, Energy meter for open systems

MULTICAL® Type 66-D is used for measuring “differential energy” in hot tap water for flats. The hot tap water is produced in a boiler station in which the cold tap water is heated by means of district heating or natural gas, and the hot tap water is then circulated to a number of homes.

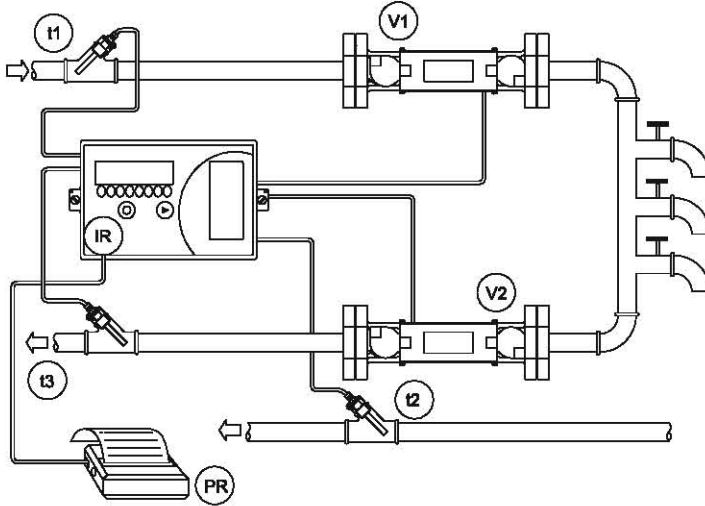

Application drawing – open systems

A MULTICAL® Type 66-D is placed in each building together with two flow meters and three temperature sensors. The energy for water is calculated on the basis of the flow temperature minus the cold tap water, whereas the energy returned is calculated on the basis of the return flow temperature minus the cold tap water. MULTICAL® Type 66-D will calculate both energy amounts separately after which it reads out the difference as consumed energy.

In certain installations where it is only possible to measure flow and return flow temperatures T1 and T3 due to the distance, the cold water temperature T2 will automatically change to a pre-programmed value, when the temperature sensor T2 is not in use.

See section 2.3.1.2 >DD< Display readings for 66-D for further information on possible readings for this meter type.

In installations where the water pressure needs to be monitored, two pressure transmitters with 4...20 mA output can be connected to a plug-in module, which is placed in the base of the unit. It is then possible to read the water pressure in the flow and return flow pipes in the display, and these values will also be included in the data-loggers. See paragraph 5. Plug-in modules.

If monthly billing is required, a printer can be connected directly to MULTICAL® Type 66-D via an IR read-out head. See section 6. Printing logged data.

1.3 66-E, Energy meter for closed systems

MULTICAL® Type 66-E is used for measuring thermal energy in closed systems with special requirements to readings, datalogging and monthly report directly from the printer.

Thermal energy is measured and calculated in the same way as 66-C. In addition, with 66-E it is possible to read and register accumulated volume and mass for both flow meter inlets V1 and V2.

See section 2.3.1.3 >DD< Display readings for 66-E for information on possible readings for this meter type.

In installations where the water pressure is to be monitored, two pressure transmitters can be connected as described above.

If monthly billing is required, a printer can be connected directly to the MULTICAL® Type 66-E via an IR-head. See section 6. Printing logged data.

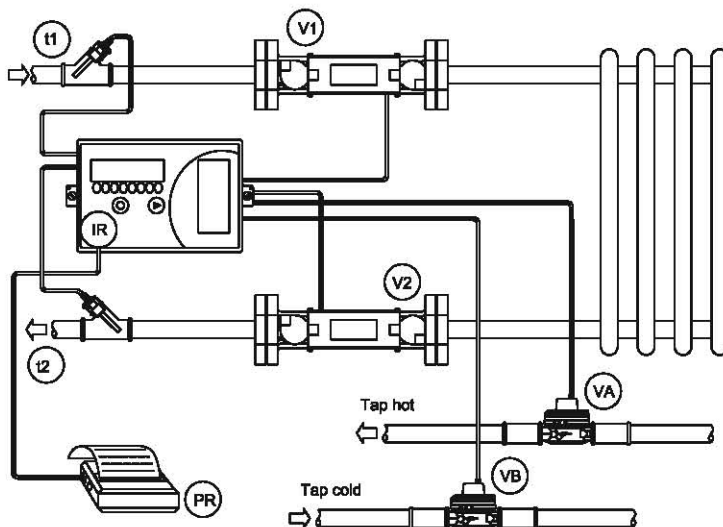

Application drawing – closed systems

1.4 Display functions

MULTICAL® Type 66-CDE is equipped with an easy-to-read LC-display containing 8 digits and 3 alphanumeric characters. During normal operation the accumulated values for thermal energy and water consumption are shown with 7 digits. The measuring units for the value (MWh, Gcal, m³ etc.) are shown with the 3 alphanumeric characters.

The first digit, to the left, is used in cases of an irregularity in the energy meter or in the installation – an “E” (Error) will appear.

The display can show a programmed customer number of up to 11 digits, however without measuring unit.

The display constantly shows the total thermal energy in MWh, kWh, GJ or Gcal, depending on the meter’s programming. When activating either the right or left front key, the following readings are displayed:

66-C Standard & leak	DD=00...59	66-D Open system	DD=80...99	66-E Closed system	DD=60...79
--------------------------------	-------------------	----------------------------	-------------------	------------------------------	-------------------

➤ Primary readings in display (right front key)

Thermal energy	kWh-MWh-GJ-Gcal	A-energy	kWh-MWh-GJ-Gcal	V1-energy	kWh-MWh-GJ-Gcal
Volume	m³-0m³	V1-volume	m³-0m³	V1-volume	m³-0m³
Hour counter	HRS	V1-mass	Ton	V1-mass	Ton
t1	°C	V1-flow	l/h-m³/h	V1-flow	l/h-m³/h
t2	°C	V1-Peak flow	l/hP-m³P	V1-peak flow	l/hP-m³P
Δt	°C	V1-power	kW-MW	V1-power	kW-MW
Power	kW-MW	V2-volume	m³-0m³	V1-peak power	kWP-MWP
Month Peak power	kWP-MWP	V2-mass	Ton	V2-volume	m³-0m³
Annual peak power	kWP-MWP	V2-flow	l/h-m³/h	V2-mass	Ton
Annual peak date	dat	t1	°C	V2-flow	l/h-m³/h
Flow	l/h-m³/h	t2	°C	t1	°C
Month Peak flow	l/hP-m³P	t3	°C	t2	°C
Annual peak flow	l/hP-m³P	Hour counter	HRS	Δt (t1-t2)	°C
Info	info	PR1	1 PRT	Hour counter	HRS
Info hour counter	info	PR2	2 PRT	PR1	1 PRT
		Info	info	PR2	2 PRT
		Info hour counter	info	Info	info
				Info hour counter	info

○ Secondary readings in display (left front key)

Cooling energy	kWh-MWh-GJ-Gcal	VA	m3a	TA2	TA2
m3tf	-	VB	m3b - EL	TA3	TA3
m3tr	-	P1	Bar	TL2	TL2
TA2	TA2	P2	Bar	TL3	TL3
TA3	TA3	Customer No.	-	VA	m3a
TL2	TL2	Time	Clk	VB	m3b - EL
TL3	TL3	Date	dat	t3	°C
VA	m3a	Target date	dat	P1	Bar
VB	m3b - EL	Qsum1	-	P2	Bar
t3	°C	Qsum2	-	Customer No.	-
P1	Bar	Segment test	-	Time	CLK
P2	Bar			Date	dat
Customer No.	-			Target date	dat
Time	CLK			Segment test	-
Date	dat				
Target date	dat				
Segment test	-				

However, only the readings selected when programming the meter will appear. See the possibilities in section 2.3 *Config., DD-E-FF-GG-M-N*.

Approx. 220 sec. after the latest activation of the front keys, the display will automatically return to the reading marked with a “1” in the DD-table – typically accumulated thermal energy.

PR1 and PR2: Print-out is activated when both front keys are activated at the same time, when the display shows

“001 PRT” or “002 PRT”.

When activating both front keys simultaneously, when the display shows accumulated energy, Qsum 1 will be shown in the display.

At the same time the leak function will be turned off until the following midnight. If both keys are depressed for approx. 10 sec. “Call” will appear on the display and a call will be activated over the built-in modem, if installed.

1.5 Temperature measuring

MULTICAL®'s high resolution A/D-converter measures both the flow and return temperatures T1 and T2 and the additional temperature sensor input T3 with a resolution of 0.01°C. Prior to each temperature measurement, an adjustment is automatically made by the internal measuring circuit. This ensures a very accurate measurement and a long term drift which is almost immeasurable.

The temperature is measured every 10th minute partly for use in calculating "average/time" and partly for each volume quantity (e.g. per 10 litres at CCC=119) for use in connection with energy calculation display readings. A temperature measurement is made every 10 sec. while the display shows one of the three temperatures.

The calculated average temperatures, per hour and per 24 hours, are only accessible via datalogging, and cannot be shown in the display.

The datalogger's "average temperature/hour" is calculated on the basis of 144 measurements (6 measurements x 24 hours).

If one or more of the temperature sensors exceed the working range 0...165°C (sensor break down or short circuit), an info code will appear after max. 10 minutes, see section 1.8 *Info codes*.

If temperature sensor T2 is turned off or short-circuited, T2 will change to an internal table value, e.g. 5°C. This internal table value will then be used for both display reading as for calculation of energy in open systems (66-D).

See section 10. *Temperature probes* for further information on resistance table, sensor types and installation conditions.

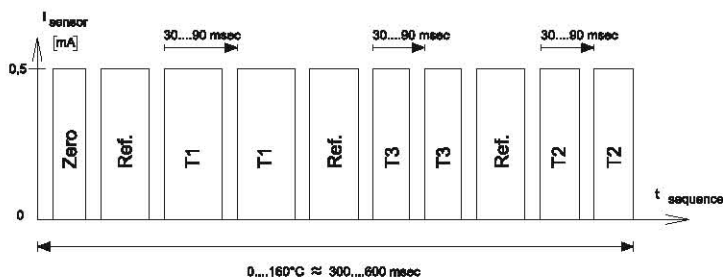

1.6 Flow measuring

Depending on the selected flow meter type the pulse input can be set to either fast pulses (CCC > 100) or to slow pulses (CCC < 100). In both instances a low-pass filter moderates bouncing, if any. Furthermore, the slow pulses are moderated by a software filter.

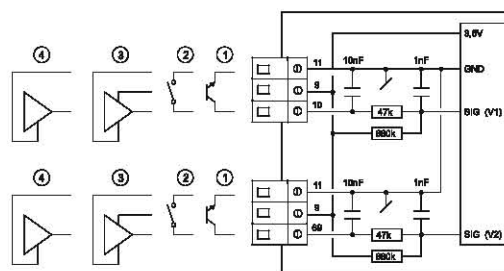

1 Flow meter with transmitter output

The signaller is typically an optocoupler with FET or transistor output, which is connected to clamp 10 and 11 for water meter V1 or clamp 69 and 11 for water meter V2.

Transistor leakage must not exceed 1 µA in OFF-state and 0.5 V in ON-state.

2 Flow meter with relay or Reed contact output

The signaller is a Reed contact, typically mounted on vane wheel and Woltmann meters or relay output from e.g. MID-meters. This type of signaller is usually used together with slow codings (CCC < 100).

3 Flow meter with active pulse output supplied by MULTICAL®

This connection is both used together with Kamstrup's ULTRAFLOW® and Kamstrup's electronic pickup for vane wheel meters. The power consumption of these units is very low and moreover is covered by MULTICAL®'s battery life time.

Connection (V1) 9: Red 10: Yellow 11: Blue
Connection (V2) 9: Red 69: Yellow 11: Blue

4 Flow meter with active output and own supply

Flow meters with active signal output as shown in circle 4. The signal level must be between 3.5 and 5 V. Larger signal levels may be connected through a passive voltage divider, e.g. of 47 kΩ/10 kΩ at a 24 V signal level.

The input has the following trigger levels:

OFF > 2.0 V
ON < 0.5 V

1.6.1 Pulse transmitter/divider

The pulse transmitter/divider, type 66-99-608 is used as an alternative to the connection PCB, which is standard in both MULTICAL® type 66-C/E and in MULTICAL® type 66-S/T.

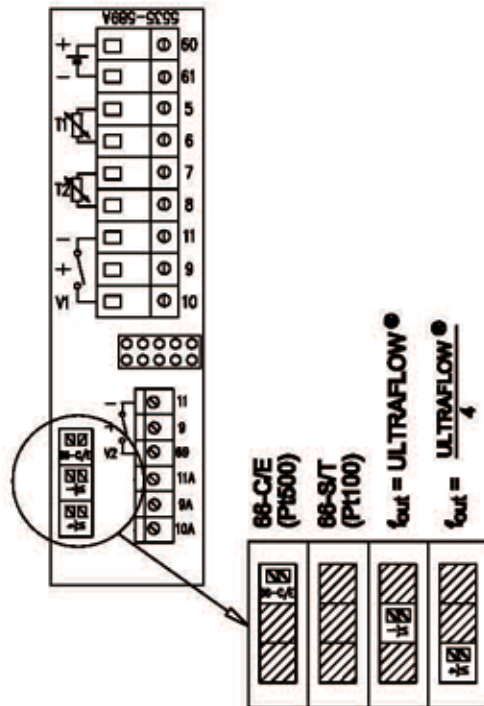

In addition to the ordinary connection PCB terminal strips for battery voltage, temperature sensors and flow meters, the pulse transmitter/divider is furnished with a galvanic isolated pulse output, which either transmits the pulses directly from the flow meter (V1) or makes a division into four of the frequency.

The pulse transmitter/divider, type 66-99-608 does not comprise connection for temperature sensor T3, and thus the PCB cannot be used for MULTICAL® type 66-D or other applications in which T3 is used.

Configuration

As the pulse transmitter/divider has several functions it is necessary to configure the PCB before making the electrical connection.

Pulse divider

If the pulse frequency on the output terminals of 9A-10A-11A has to be identical with the pulse frequency on the input terminals of 9-10-11, a piece of solder must be placed at the "V1/1" symbol. If the output frequency should be divided by 4, the solder must be placed at the "V1/4" symbol.

"V1/1" results in a pulse duration of approx. 3.9 msec., whereas "V1/4" results in a pulse duration of approx. 22 msec.

NB.: When the pulse transmitter/divider, type 66-99-608 is installed in a MULTICAL® with battery supply, the battery lifetime will typically be halved, depending on the average water flow/number of pulses. Furthermore, the MULTICAL® receiving the pulses will get a battery load corresponding to an ULTRAFLOW®. If this is not acceptable, please select net supply.

1.7 Energy calculation

MULTICAL® 66-C + 66-E calculate energy according to the formula in EN 1434-1, which simplified can be summed up as follows:

$EMJ =$	$V \times \Delta\theta \times k$	[MJ]
$E_{GJ} =$	$\frac{EMJ}{1000}$	[GJ]
$E_{kWh} =$	$\frac{EMJ}{3.6}$	[kWh]
$E_{MWh} =$	$\frac{EMJ}{3600}$	[MWh]
$E_{Gcal} =$	$\frac{EMJ}{4186.8}$	[Gcal]

V is the added (or simulated) water volume during verification. In connection with a MULTICAL® e.g. with qp 1.5 m³/h flow meter and CCC-code = 119, the integrator will be programmed to receive 100 volume pulses per liter.

If e.g. 10,000 volume pulses are added, this will correspond to 10,000/100 = 100 litres, or 0.1 m³.

$\Delta\theta$ is the difference between the flow and the return temperature ($t_f - t_r$).

k indicates the water heat coefficient, which is found by consulting "Tabellen von Wärmekoeffizienten für Wasser als Wärmeträgermedium", published in 1986 by Wirtschaftsverlag NW.

Please note that when consulting these tables following information must be available:

- Flow temperature, t_f
- Return temperature, t_r
- Flow meter placing: flow or return flow
- Installation pressure (16 bar according to EN 1434)

The k-factor is stated in the table as basis for the energy calculation in MJ and must, therefore, be converted according to above formulars, when the energy should be expressed in other units of measurement.

In connection with bifunctional energy metering, heat is measured with positive $\Delta\theta$, whereas cooling is measured with negative $\Delta\theta$. However, cooling metering implies that the flow temperature is less than a programmed limit of e.g. 25°C as shown in the graph below.

MULTICAL® measures energy throughout the temperature range 0...160°C, with a high degree of accuracy – as illustrated below.

66-D:

$$EMJ = (V1 \times (T1 - T2) \times k_{(T1)}) - (V2 \times (T3 - T2) \times k_{(T3)}) \text{ [MJ]}$$

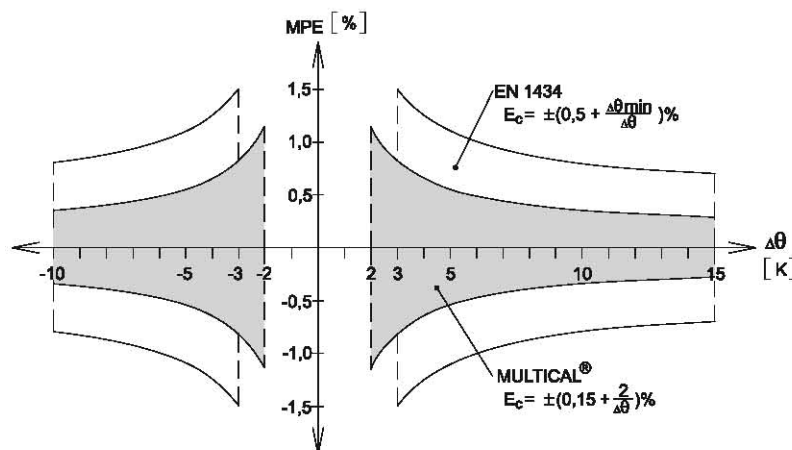
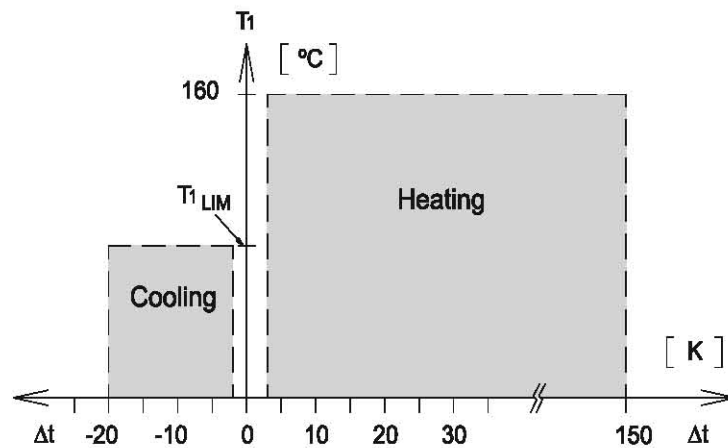

1.7.1 Σ Quick figures

The sum of the Quick figures, which e.g. is calculated during a verification process is called Σ Quick figures.

Quick figures are displayed by a zero followed by 6 digits. Thus, the Quick sum has a maximum value of 999.999. If the total Quick sum exceeds 999.999, a roll-over will occur. The Quick sum is accessed through the data output and on the display, and in addition it can be transmitted as pulses from a test print.



Display prior to overflow

The accumulated Quick figure, which MULTICAL® under ideal circumstances should emit during commissioning, can be determined as a calculation of the “true” energy multiplied by the high-resolution Quick-factor:

Quick figure = $E_{GJ} \cdot Q_{GJ}$ or $E_{MWh} \cdot Q_{MWh}$, where Q_{GJ} and Q_{MWh} can be read in below Quick table:

CCC-kode (see section 2.2.1)	Q_{GJ}	Q_{MWh}	No. of decimals [m³] in display
107, 184	23,889,000	86,000,000	3
000, 001, 002, 009, 108, 109, 110, 111, 112, 115, 116, 117, 118, 119, 121, 122, 123, 124, 125, 126, 132, 133, 134, 136, 138, 139, 156, 163, 164, 165, 183, 185	2,388,900	8,600,000	2
003, 004, 006, 113, 114, 120, 127, 128, 129, 130, 131, 135, 137, 140, 141, 142, 143, 151, 152, 153, 157, 168, 178, 179, 184, 186, 187, 188, 189	238,890	860,000	1
005, 007, 008, 144, 145, 146, 147, 148, 149, 150, 158, 169, 170, 173, 175, 176, 177, 180, 181, 191, 192, 193	23,889	86,000	0
166, 167, 171, 172	2,388.9	8,600	x10

Example of calculation of the “true” Quick figure:

- MULTICAL, programmed for qp 1.5 m³/h flow meter (CCC=119)
 - Placed in flow pipe
 - 10,000 volume pulses are emitted, corresponding to 0.1 m³
 - The temperature is simulated as $t_f = 43.00^\circ\text{C}$ and $t_r = 40.00^\circ\text{C}$
- $EMJ = V \times \Delta\theta \times k = 0.1 \times 3 \times 4.1408 = 1.2422 \text{ [MJ]}$
- True Quick = $GJ \cdot \text{Quick factor} = 0.0012422 \cdot 2,388,900 = \mathbf{2967.49}$

1.7.2. QuickTransmitter

The QuickTransmitter type 66-99-277 can be used when testing and verifying MULTICAL® Type 66-C/E, if high resolution energy pulses are required. However, the QuickTransmitter cannot be used to test and verify MULTICAL® 66-D.

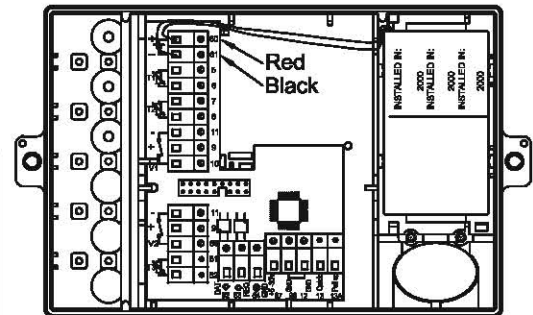

The unit is supplied from an external voltage supply with 5...30 VDC, max. 15 mA. The Quick pulses are emitted as an open collector signal on clamp nos. 12 and 13 – an internal pull-up resistance of 10 kW can be connected via clamp no. 13A (see connection diagram below).

Volume and temperature simulation can be connected onto T1-T2-V1. In addition, the unit can be connected to serial data reading on clamp nos. 62-63-64, using data cable type 66-99-106 to connect to the com port of a computer (see paragraph 5.1 for how to connect the data cable), to read data use PC program “METERTOOL LogView”.

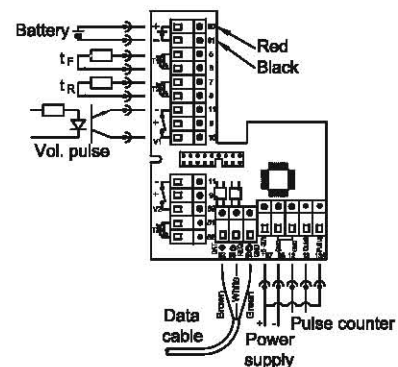

- Voltage supply: 5...30 VDC, < 15 mA.
- Volume simulation: 0-128 Hz ; depending on CCC-koding.
- Quickpulse output: Open collector, 5...30 VDC, < 15 mA.
- Quickpulse resolution: See Quick table paragraph 1.7.1.
- Quickpulse frequency: Approx. 40 kHz in burst/integration.
- Maintenance: The 17-poled plug should be replaced after every 500 tests.

1.8 Info codes

MULTICAL® Type 66-CDE constantly monitors a number of important functions. In cases of serious defects in the measuring system or in the installa-

tion, an "E" will appear farthest to the left in the display, and an info code can be read by activating the right front key until the measuring unit shows "info" at the right in the display.

Info code	Description	Reaction time	Comments
000	No irregularities have been detected	-	
001	The primary supply (battery or network supply) is missing	10 sec.	Power failure < 5 minutes are covered by a backup cell in the meter's supply module (if external supply are used)
008	Temperature sensor T1 outside measuring range	1... 10 min.	Measuring for T1-T2-T3 is 0°C ... 165°C
004	Temperature sensor T2 outside measuring range	1... 10 min.	See table below for relations between info 004/032 and 66-CDE
032	Temperature sensor T3 outside measuring range	1... 10 min.	
064	Leak in the cold water system	24 hours	ON/OFF and sensitivity is selected at config. "N"
256	Leak in the heat system	24 hours	ON/OFF and sensitivity is selected at config. "M"
512	Bursting in the heat system	90 sec.	ON/OFF is selected at config. "M"

Type number 66 - - - - - - -

Info 032 not active C

Info 032 active D

Info 032 not active E

66-D - info 004 will not be active, when the sensor types A-E are selected (2 sensors in pairs)

66-D - info 004 will be active, when the sensor types L-R are selected (3 sensors in sets)

If the primary supply fails info will become = 001, and the hour counter will stop.

Regardless of what info code has been activated, the info hour counter will count the number of hours where info has been larger than zero.

When an info code appears it will be stored in the dataloggers, which will constantly be up-dated with intervals of 1 hour till 1 year. See section 4.2 *Specific dataloggers for 66-CDE.*

In addition an info logger is connected to the info function, with a time stamped datalogger every time an info code shall be set or deleted. Info logger contains information of the past 10 "events", which can be read by MULTITERM and via the PC program of METERTOOL.

Info	Date	Time	E1_2 [MWh]
1	00-11-24	09:54:20	0,07
9	00-11-24	10:00:00	0,07
13	00-11-24	10:00:00	0,07
12	00-11-24	11:01:10	0,07
4	00-11-24	11:03:45	0,07
0	00-11-24	11:03:45	0,07
8	00-11-27	09:34:50	0,07
12	00-11-27	09:34:50	0,07
13	00-11-27	14:05:20	0,07
12	00-11-27	14:44:50	0,07

66-B ⇒ 66-CDE

The "E" in the display and the information code are only shown while the defect exists. Thus there is no need for Reset information in MULTICAL® type 66-CDE.

1.9 Reset functions

1.9.1 Reset hour counter

Reset of both hour counters for operating hours and info hours is made by first lifting the top of the calculator from the connection base for at least 10 seconds until the control segments in the display stop. The left front key is then activated, and at the same time the top of the calculator is put back in place on the connection base. The left front key is now activated for up till 10 seconds, until the control segments in the display start moving again.



1.9.2 Total reset

Zero setting of the legal registers in MULTICAL® Type 66-CDE for energy and water can only be made by activating “RESET”, which is placed on the underside of the top of the calculator.

“RESET” is protected by a verification label. When “RESET” has been made the meter must be reverified according to current national requirements, after which “RESET” and “LOCK” must be sealed again.

 **All display registers, peak values and average calculations will be cancelled by “RESET”. “RESET” does not affect dataloggers.**



Reset pen, type 66-99-278

1.9.3 Reset of dataloggers

To reset the dataloggers in MULTICAL® Type 66-CDE the verification seal must be broken after which the dataloggers can be reset by means of the PC-program METERTOOL.

See section 7. *Programming via METERTOOL.*

1.9.4 Reset peak values

Separate adjustment of peak values for monthly and yearly peak can be made by lifting the top of the integrator from the connection for at least 10 sec. until the control segment of the display stops. The right front key is activated, and at the same time the top of the integrator is placed in the connection bracket. The right front key is activated for up to 10 sec., until the control segments of the display moves again.

 **This facility can only be used for meters with S/N > 4050375**

2. Number system

The number system below describes the way in which MULTICAL® Type 66-CDE is built up with a view to ordering.

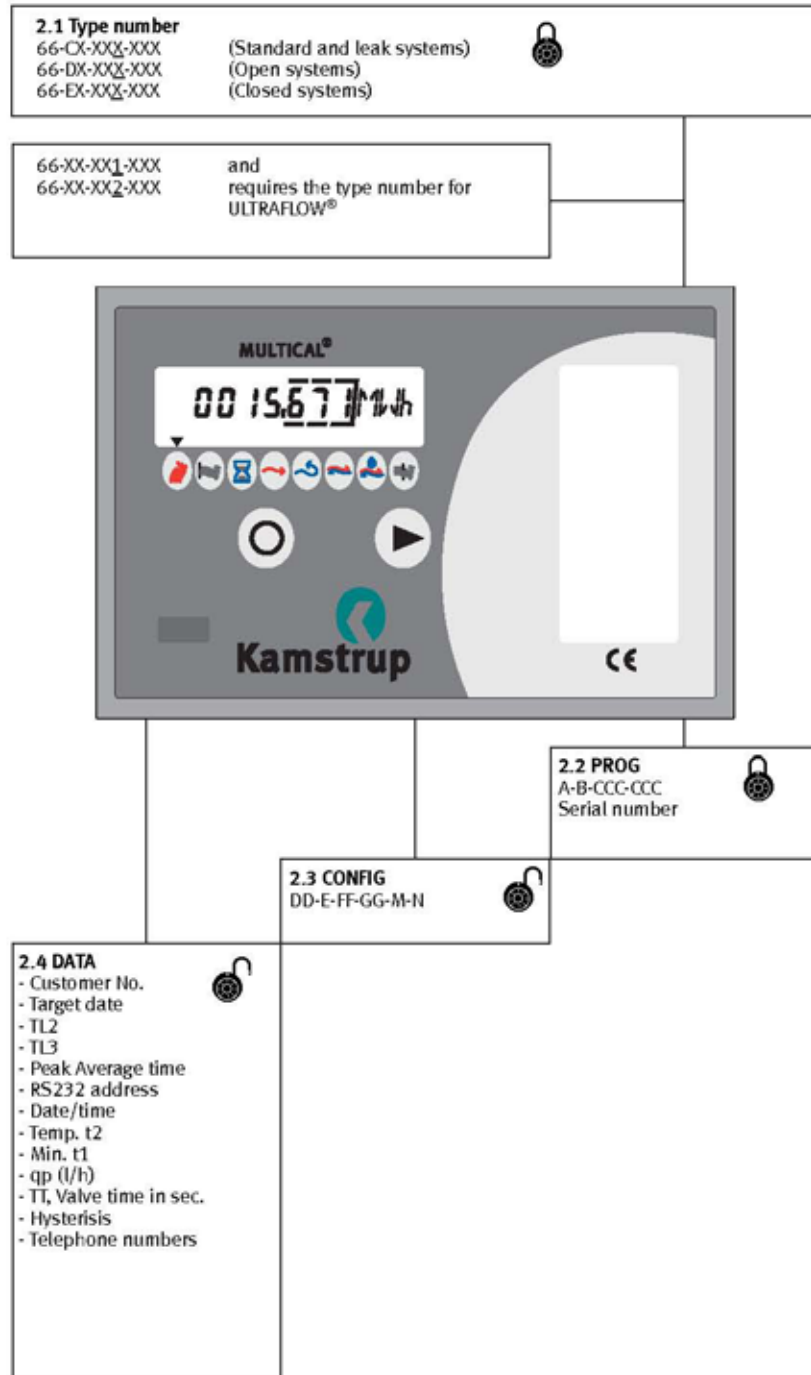

2.1 Type number

Type number	66	-	□	-	□	-	□	-	□	-	□	-	□	-	□□□
Standard and leak systems			C												
Open systems			D												
Closed systems			E												
Plug-In modules	None	0													
Data/pulse inputs		1													
Data/pulse outputs		2													
Telephone modem/pulse inputs + Data		3													
M-Bus, EN 1434/pulse inputs - MC®66		4													
Telephone modem/pulse outputs		5													
M-Bus, EN1434/pulse outputs - MC®III		7													
M-Bus/pulse inputs - MC®66		8													
M-Bus/pulse outputs - MC®66		9													
Radio/pulse inputs		A													
Radio/pulse inputs external Antenne		B													
ZigBee 2,4 GHz, int. ant. + pulse inputs		C													
4...20 mA inputs/Data /pulse inputs		D													
Analoque outputs		E													
LonWorks, FTT-10A/pulse inputs/outputs		F													
Radio/pulse outputs		G													
Radio/pulse outputs external Antenne		H													
Supply modules	None	0													
D-cell, HiCap lithium battery		2													
230 VAC supply module		7													
24 VAC supply module		8													
24 V supply with SO input		5													
24 V supply with flow meter input		6													
Pt 500 Temperature sensors	None	0													
Pocket sensor set with 1.5 m cable		A													
Pocket sensor set with 3.0 m cable		B													
Pocket sensor set with 5.0 m cable		C													
Pocket sensor set with 10.0 m cable		D													
Short direct sensor set with 1.5 m cable		F													
Short direct sensor set with 3.0 m cable		G													
3 Pcs. Pocket sensor set with 1.5 m cable		L													
3 Pcs. Pocket sensor set with 3.0 m cable		M													
3 Pcs. Pocket sensor set with 5.0 m cable		N													
3 Pcs. Pocket sensor set with 10.0 m cable		P													
Pick-up/Flow meter	None	0													
Supplied with 1 pcs. ULTRAFLOW® *)		1													
Supplied with 2 pcs. (alike) ULTRAFLOW® *)		2													
Kamstrup pick-up with spring lock 2.5 m cable		F													
Country code															XXX

66-B ⇒ 66-CDE

The modules 8-9-D-E are not compatible with MULTICAL® III, type 66-B, but can be used in MULTICAL® 66-CDE.

*) ULTRAFLOW® must be stated separately (see next page)



66-C and 66-D must use identical flow meters on V1 and V2 (CCC_{V1}=CCC_{V2}) 66-E can use individual flow meters on V1 and V2.

2.1.1 ULTRAFLOW® type numbers

When placing an order it should be noted that MULTICAL® Type 66-CDE can be ordered for supply without a flow meter or together with one or two

ULTRAFLOW® flow meters. However, supply with two pcs. ULTRAFLOW® is only possible in connection with the smallest construction sizes. The list below indicates which meter types can be used in leak detecting systems:

Type number 66 - C/D/E - - - - -

Supplied without flow meter/pick-up	0
Supplied with 1 pcs. ULTRAFLOW®	1
Supplied with 2 pcs. (identical) ULTRAFLOW®	2

UF 65-X Type number	qp (m³/h)	CCC	Size	Leakage	1	2
65-X-CAAA-XXX	0.6	116	G¾B (R½)	✓	✓	✓
65-X-CAAD-XXX	0.6	116	G1B (R¾)	✓	✓	✓
65-X-CDAC-XXX	1.5	119	G¾B (R½)	✓	✓	✓
65-X-CDAD-XXX	1.5	119	G1B (R¾)	✓	✓	✓
65-X-CDAE-XXX	1.5	119	G1B (R¾)	✓	✓	✓
65-X-CDAF-XXX	1.5	119	G1B (R¾)	✓	✓	✓
65-X-CDAA-XXX	1.5	119	G¾B (R½)	✓	✓	✓
65-X-CFAF-XXX	3.0	136	G1B (R¾)	✓	✓	✓
65-X-CFBA-XXX	3.0	136	DN20	✓	✓	*
65-X-CGAG-XXX	3.5	151	G½/4 (R1)	✓	✓	*
65-X-CGBB-XXX	3.5	151	DN25	✓	✓	*
65-X-CHAG-XXX	6.0	137	G½/4 (R1)	✓	✓	*
65-X-CHBB-XXX	6.0	137	DN25	✓	✓	*
65-X-C1AJ-XXX	10	137	G2B (R1½)	✓	✓	*
65-X-C1BD-XXX	10	137	DN40	✓	✓	*
65-X-CJAJ-XXX	10	178	G2B (R1½)	✓	✓	*
65-X-CJBD-XXX	10	178	DN40	✓	✓	*
65-X-CKBE-XXX	15	120	DN50	✓	✓	*
65-X-CLBG-XXX	25	179	DN65	✓	✓	*
65-X-C2BG-XXX	25	120	DN65	✓	✓	*
65-X-CMBH-XXX	40	158	DN80	✓	✓	*
65-X-FABL-XXX	60	170	DN100	*	*	*
65-X-FACL-XXX	60	170	DN100	*	*	*
65-X-FBCL-XXX	100	180	DN100	*	*	*
65-X-FCBN-XXX	150	147	DN150	*	*	*
65-X-FCCN-XXX	150	147	DN150	*	*	*
65-X-FDBN-XXX	250	181	DN150	*	*	*
65-X-FDCN-XXX	250	181	DN150	*	*	*
65-X-FEBN-XXX	400	171	DN150	*	*	*
65-X-FECN-XXX	400	171	DN150	*	*	*
65-X-FECP-XXX	400	171	DN200	*	*	*
65-X-FEBR-XXX	400	171	DN250	*	*	*
65-X-FECR-XXX	400	171	DN250	*	*	*
65-X-FFCP-XXX	600	172	DN200	*	*	*
65-X-FFCR-XXX	600	172	DN250	*	*	*
65-X-F1BR-XXX	1000	172	DN250	*	*	*
65-X-F1CR-XXX	1000	172	DN250	*	*	*

2.2 Prog., A-B-CCC-CCC

Following programs are usually determined when placing the order, and thus they can only be chan-

ged by total programming, which subsequently demands reverification.

Prog. number A - B - CCC (V1) - CCC (V2)
 - - -

Flow meter installation:

k-factor table	- Flow	3
	- Return	4

Measuring unit, Energy

- GJ	2
- kWh	3
- MWh	4
- Gcal	5

Flow meter code (CCC-table)

CCC	CCC
-----	-----

66-B ⇒ 66-CDE
 A=1 & 2 is removed – total reset of counter registers only can be made by short circuiting behind the seal. See section 1.9 Reset functions.

Note! Gcal is not an SI-unit and may therefore not be used in Europe.

2.2.1 CCC-Table for MULITCAL® Type 66-CDE

2.2.1.1 ULTRAFLOW®II

CCC No.	Pre-counter	Flow factor	Number of decimals displayed								pulse/l	qp (m³/h)	Type No.
			kWh	MWh Gcal	GJ	m³	l/h	m³/h	kW	MW			
116	3000	102	0	3	2	2	0		1		300	0.6	65 54 A8X 65 54 AAX
119	1000	307	0	3	2	2	0		1		100	1.5	65 54 A6X 65 54 A7X 65 54 A1X 65 54 A2X 65 54 A3X
136	500	614	0	3	2	2	0		1		50.0	2.5	65 54 A4X 65 54 ADX
151	5000	614		2	1	1	0		1		50.0	3.5	65 54 B1X 65 54 B7X
137	2500	1229		2	1	1	0		1		25.0	6 6 10 10	65 54 B2X 65 54 B5X 65 54 BGX 65 54 BHX
120	1000	3072		2	1	1	0		1		10.0	15 25	65 54 B4X 65 54 B8X
158	5000	614		1	0	0		2	0		5	40	65 54 B9X
170	2500	1229		1	0	0		2		3	2.5	60	65 54 BAX
147	1000	3072		1	0	0		2		3	1	150	65 54 BBX
171	4000	768		0	x10	x10		1		2	0.4	400	65 54 BCX
172	2500	1229		0	x10	x10		1		2	0.25	1000	65 54 BKX

2.2.1.2 ULTRAFLOW® type 65-X

CCC No.	Pre-counter	Flow factor	Number of decimals displayed								pulse/l	qp (m³/h)	Type No.
			kWh	MWh Gcal	GJ	m³	l/h	m³/h	kW	MW			
116	3000	102	0	3	2	2	0		1		300	0.6	65-X-CAAA-XXX 65-X-CAAD-XXX
197	1500	205	0	3	2	2	0		1		150	1	
119	1000	307	0	3	2	2	0		1		100	1.5	65-X-CDAC-XXX 65-X-CDAD-XXX 65-X-CDAE-XXX 65-X-CDAF-XXX 65-X-CDAA-XXX
198	600	512	0	3	2	2	0		1		60	2.5	
136	500	614	0	3	2	2	0		1		50.0	3.0	65-X-CFAF-XXX 65-X-CFBA-XXX
151	5000	614		2	1	1	0		1		50.0	3.5	65-X-CGAG-XXX 65-X-CGBB-XXX
137	2500	1229		2	1	1	0		1		25.0	6 6 10 10	65-X-CHAG-XXX 65-X-CHBB-XXX 65-X-C1AJ-XXX 65-X-C1BD-XXX
178	1500	2048		2	1	1	0		1		15.0	10	65-X-C1AJ-XXX 65-X-C1BD-XXX
120	1000	3072		2	1	1	0		1		10.0	15	65-X-CKBE-XXX
179	600	5120		2	1	1	0		1		6.0	25	65-X-CLBG-XXX
120	1000	3072		2	1	1	0		1		10.0	25	65-X-C2BG-XXX
158	5000	614		1	0	0		2	0		5.0	40	65-X-CMBH-XXX
170	2500	1229		1	0	0		2		3	2.5	60	65-X-FABL-XXX 65-X-FACL-XXX
180	1500	2048		1	0	0		2		3	1.5	100	65-X-FBCL-XXX
147	1000	3072		1	0	0		2		3	1.0	150	65-X-FCBN-XXX 65-X-FCCC-XXX
181	600	5120		1	0	0		2		3	0.6	250	65-X-FDBN-XXX 66-X-FDCN-XXX
171	4000	768		0	x10	x10		1		2	0.4	400	65-X-FEBN-XXX 65-X-FEBR-XXX 65-X-FECN-XXX 65-X-FECP-XXX 65-X-FECP-XXX
172	2500	1229		0	x10	x10		1		2	0.25	600 600 1000 1000	65-X-FFCP-XXX 65-X-FFCR-XXX 65-X-F1BR-XXX 65-X-F1CR-XXX
182	1500	2048		0	x10	x10		1		2	0.15	1000	65-X-FGBR-XXX

2.2.1.3 ULTRAFLOW® CCC codes for testing

CCC No.	Pre-counter	Flow factor	Number of decimals displayed								pulse/l	qp (m³/h)	Type No.
			kWh	MWh Gcal	GJ	m³	l/h	m³/h	kW	MW			
184	300	102	1		3	3	0		1		300	0.6	Test
199	150	205	1		3	3	0		1		150	1	Test
107	100	307	1		3	3	0		1		100	1.5	Test
136	500	614	0	3	2	2	0		1		50.0	3.5	Test
138	250	1229	0	3	2	2	0		1		25.0	6 10	Test
183	150	2048	0	3	2	2	0		1		15.0	10	Test
185	100	3072	0	3	2	2	0		1		10.0	15 25	Test
186	500	614		2	1	1		2	0		5.0	40	Test
187	250	1229		2	1	1		2		3	2.5	60	Test
188	150	2048		2	1	1		2		3	1.5	100	Test
189	100	3072		2	1	1		2		3	1.0	150	Test
191	400	768		1	0	0		1		2	0.4	400	Test
192	250	1229		1	0	0		1		2	0.25	1000	Test
193	150	2048		1	0	0		1		2	0.15	1000	Test

Note! Above CCC codes cause 10 times more integrations compared to standard codes, and thereby the battery lifetime is reduced. Furthermore, there will be no possibility of data communication at high actual water flow, neither via input modules nor via the optical eye.

2.2.1.4 Mechanical flow meters with Reed-contact

CCC No.	Pre-counter	Flow-factor	Number of decimals displayed						l/imp.	imp./l	Qmax (m³/h)
			kWh	MWh Gcal	GJ	m³	m³/h	MW			
000	10	3072		3	2	2	2	3	1	1	3
001	4	7680		3	2	2	2	3	2.5	0.4	6
002	1	3072		3	2	2	1	2	10	0.1	30
003	4	7680		2	1	1	1	2	25	0.04	60
004	10	3072		2	1	1	1	2	10	0.1	30
005	40	7680		1	0	0	1	2	25	0.04	60
006	1	3072		2	1	1	0	1	100	0.01	300
007	4	7680		1	0	0	0	1	250	0.004	600
008	1	30720		1	0	0	0	1	1000	0.001	2500
009	28	1097	0	3	2	2	2	3	0.357	2.8000	1.5

⚠ With CCC=00X the display updating of water flow and power will be 30 sec. as opposed to 10 sec. for other CCC-codes.

CCC=00X cannot be used in connection with meters with S/N < 4.047.000

2.2.1.5 Electronical flow meters with passive output

CCC No.	Pre-counter	Flow-factor	Number of decimals displayed					l/pulse	pulse/l	qp (m³/h)	Type
			MWh Gcal	GJ	m³	m³/h	MW				
147	1000	3072	1	0	0	2	3	1	-	18...75	SC-18
148	400	7680	1	0	0	2	3	2.5	-	120...300	SC-120
166	1000	3072	0	x10	x10	1	2	10	-	450...1200	SC-450
167	200	15360	0	x10	x10	1	2	50	-	1800...3000	SC-1800
175	7500	410	1	0	0	2	3	-	7.5	15...30	DF-15
176	4500	683	1	0	0	2	3	-	4.5	25...50	DF-25
177	2500	1229	1	0	0	2	3	-	2.5	40...80	DF-40

2.2.1.6 Vane wheel meters with pick-up

CCC No.	Pre-counter	Flow-factor	Number of decimals displayed								pulse/l	qp (m³/h)	T type
			kWh	MWh Gcal	Gj	m³	l/h	m³/h	kW	MW			
102	560	549	0	3	2	2	0		1		56.0	1.5/2.5	GWF-MT3
103	300	1024	0	3	2	2	0		1		30.0	3.5	GWF-MT3
104	2520	1219		2	1	1	0		1		25.2	6	GWF-MT3
105	1230	2498		2	1	1	0		1		12.3	10	GWF-MT3
106	1080	2844		2	1	1	0		1		10.8	15	GWF-MT3
108	1403	219	0	3	2	2	0		1		140.3	0.6	GWF
109	957	321	0	3	2	2	0		1		95.7	1.0	GWF
110	646	476	0	3	2	2	0		1		64.6	1.5	GWF
111	404	760	0	3	2	2	0		1		40.4	1.5 2.5	HM GWF
112	502	612	0	3	2	2	0		1		50.2	1.5 - 2.5*	GWF
113	2350	1307		2	1	1	0		1		23.5	3.5 - 6*	GWF
114	712	4315		2	1	1	0		1		7.12	10 - 15*	GWF
115	757	406	0	3	2	2	0		1		75.7	1.0*	GWF
116	3000	102	0	3	2	2	0		1		300.0	0.6*	GWF
117	269	1142	0	3	2	2	0		1		26.9	1.5	Brunata
118	665	462	0	3	2	2	0		1		66.5	1.5	Aquastar
119	1000	307	0	3	2	2	0		1		100.0	0.6	HM
121	294	1045	0	3	2	2	0		1		29.4		
122	1668	184	0	3	2	2	0		1		166.8	0.6	HM
123	864	356	0	3	2	2	0		1		86.4	0.75 - 1*	HM
124	522	589	0	3	2	2	0		1		52.2	2.5 1.5*	CG HM
125	607	506	0	3	2	2	0		1		60.7	1.5 - 1* 1.5*	HM
126	420	731	0	3	2	2	0		1		42.0	1.0 2.5*	CG HM
127	2982	1030		2	1	1	0		1		29.82	2.5-3.5*	HM
128	2424	1267		2	1	1	0		1		24.24	3.5*	HM
129	1854	1657		2	1	1	0		1		18.54	6*	HM
130	770	3990		2	1	1	0		1		7.7	10*	HM
131	700	4389		2	1	1	0		1		7.0	15*	HM
132	365	841	0	3	2	2	0		1		36.54	2.5	Wehrle
133	604	508	0	3	2	2	0		1		60.47	1.5	Wehrle
134	1230	250	0	3	2	2	0		1		123.05	0.6	Wehrle
135	1600	1920		2	1	1	0		1		16.0	10*	HM
139	256	1200	0	3	2	2	0		1		25.6	1.5 - 2.5	GWF
140	1280	2400		2	1	1	0		1		12.8	3.5 - 5.0	GWF
141	1140	2695		2	1	1	0		1		11.4	6	GWF
142	400	768		2	1	1		2		3	4	10	GWF
143	320	960		2	1	1		2		3	3.2	10 - 15	GWF
144	1280	2400		1	0	0		2		3	1.28	25 - 40	GWF
145	640	4800		1	0	0		2		3	0.64	60	GWF
146	128	24000		1	0	0		2		3	0.128	125	GWF
152	1194	2573		2	1	1	0		1		11.94	10	GWF
153	1014	3030		2	1	1	0		1		10.14	15	GWF
156	594	517	0	3	2	2	0		1		59.4	1.5	Metron
157	3764	816		2	1	1	0		1		37.64	2.5	Metron
163	1224	251	0	3	2	2	0		1		122.4	0.6 - 1.0	GWF/U2
164	852	360	0	3	2	2	0		1		85.24	1.5	GWF/U2
165	599	513	0	3	2	2	0		1		59.92	2.5	GWF/U2
168	449	6848		2	1	1	0		1		4.486	15/25	HM/WS
169	1386	2216		1	0	0		2	0		1.386	40	HM/WS
173	500	615		1	0	0		1		2	0.5	80	Westland

* = multijet

2.3 CONFIG., DD-E-FF-GG-M-N

CONFIG. describes the configuration possibilities that MULTICAL® Type 66-CDE can offer.

Changes in CONFIG. which do not change the legal energy calculation, can be made without subsequent reverification.

As MULTICAL® Type 66-C is type approved for billing with respect to both "energy" and "volume" changes affecting the first two display readings can only be made by total programming.

66-B ⇒ 66-CDE

The table at the right indicates which DD-codes from 66-B are totally or partially covered by DD-codes for 66-C.

66-C	66-B
12	13-23-32
16	17-22-27-31
18	19-33
20	29-34
24	37

2.3.1.1 >DD< Display indication codes for 66-C

66-C Standard og læk	DD=00...59
--------------------------------	-------------------

		▶ Primary display readings																											
	12	16	18	20	21	24	28	36	39	40	41	42	43	44	45	46	47	48	49	50	51	52	53	54	55	56	57	58	
Heat energy	1	1	1	1	1	1		11	1	1	1	1	1		1	1	1	1	2	1	1	1		1	2	2	1	1	
Volume	2	2	2	2	2	2	3	1	2	2	2	2	2	1	2	2	2	2	1	2	2	2	2	2	1	1	2	2	
Hour counter	3	3	3	3	3	3		2	3	3	3	3	3	4	3	3	3	3	3	3	3	3	3	3	3	3	3	3	
t1	4	4	4	4	4	4		3	4	4	4	4	4		4	4	4	4	4	4	4	4	4	4	4	4	4	4	
t2	5	5	5	5	5	5		4	5	5	5	5	5		5	5	5	5	5	5	5	5	5	5	5	5	5	5	
Δt (t1-t2)	6	6	6	6	6	6		5	6	6	6	6	6		6	6	6	6	6	6	6	6	6	6	6	6	6	6	
Power	7	7	7	7	7	7		6	7	7	7	7	7		7	7	7	7		7	7	7	7			8	7		
Peak power	8	8	8	8							8	8			8	8					8	8							
Annual Peakpwr				9							9	9	8		8	9	8								8	9			
Annual Peak date				10							10	10	9		9	10	9								9	10			
Flow	9	9	9	11	8	8	1	7	8	8	11	11	10	2	9	10	11	10	7	8	9	9	8		7	7	8	7	
Peak flow				12	9	9	2	8			12	12		3	10		12				10	10							
Annual Peak flow				13	10						13	13					13												
Info	10	10	10	14	11	10		9	9	9	14	14	11		11	11	14	11	8	9	11	11	9	7	10	11	9	8	
Info hour counter	11	11	11	15	12	11		10	10	10	15	15	12		12	12	15	12	9	10	12	12	10	8	11	12	1	9	

		○ Secondary readings																											
	12	16	18	20	21	24	28	36	39	40	41	42	43	44	45	46	47	48	49	50	51	52	53	54	55	56	57	58	
Cooling energy										A													A						
m3tf													C			C		C											
m3tr													D			D		D											
TA2		A		A		A		A		A	A	A	A			A	A	A	A	B	A		C	A	A	A	C		
TA3		B		B	A	B		B		B	C	C	B			B	C	B	B	C	B		1	B	B	B	E		
TL2		C		C						C	B	B			A		B						D	C			D		
TL3		D		D						D	D	D			B		D						B	D			F		
VA			A	E						B	E		E			E		E		A				E			A		
VB			B	F						C	F		F			F								F			B		
t3				G						D																			
P1				H						E																			
P2				I						F																			
Customer No.	A	E	C	J	B	C	A	C	G	G	E	G	E	A	C	G	E	F	C	D		A	E	G	C	C	G	A	
Clock				K											D		F	G										B	
Date	B	F	D	L	C	D		D	H	H	F	H	F		E	H	G	H	D	E	C	B	F	H	D	D	H	C	
Target date	C	G	E	M	D	E		E			G	I	G			I	H	I	E	F	D		G		E	E			
Segment test	D	H	F	N	E	F	B	F	I	I	H	J	H	B	F	J	I	J	F	G	E	C	H	II	F	F	J	D	

2.3.1.2 >DD< Display indication codes for 66-D

66-D Open system	DD=80...99
-----------------------------------	-------------------

> Primary display readings												
	80	81	82									
Δ-energy	1	1	1									
V1-volume	2		2									
V1-mass ¹⁾		2										
V1-flow	3	3										
V1-Peak flow	4	4										
V1-Power	5											
V2-volume	6		3									
V2-mass ¹⁾		5										
V2-flow	7	6										
t1	8	7	4									
t2	9	8	5									
t3	10	9	6									
Hour counter	11	10	7									
PR1	12	11	8									
PR2	13	12	9									
Info	14	13	10									
Info hour counter	15	14	11									

O Secondary display readings												
	80	81	82									
VA	A	A	A									
VB	B	B	B									
P1	C	C	C									
P2	D	D	D									
Customer No.	E	E	E									
Clock	F	F	F									
Date	G	G	G									
Target date	H	H	H									
Qsum1	I	I	I									
Qsum2	J	J	J									
Segment test	K	K	K									

¹⁾ Display of mass will be updated every hour.

2.3.1.3 >DD< Display indication codes for 66-E

66-E Closed system	DD=60...79
------------------------------	-------------------

➤ Primary display readings												
	60	61	62	63	64	65	66	67		79		
V1-energy	1	1	1	1	1	1	1	1				
V1-volume	2	2	2	2	2	2	2	2				
V1-mass ¹⁾						3						
V1-flow	3	3	3	3	3	4	3			3		
V1-peak flow			4	4		5	4					
V1-Power	4	4	5	5	4	6	5					
V1-peak power	5	5			5	7	6					
V2-volume	6		6		6	8	A	3				
V2-mass ¹⁾						9						
V2-flow	7		7		7	10	B			4		
t1	8	6	8	6	8	11	7	4		1		
t2	9	7	9	7	9	12	8	5		2		
Δt (t1-t2)	10	8	10	8	10	13	9	6				
Hour counter	11	9	11	9	11	14	10	7				
PR1	12	10	12	10	12	15		8				
PR2	13	11	13	11	13	16		9				
Info	14	12	14	12	14	17	11	10				
Info hour counter	15	13	15	13	15	18	12	11				

○ Secondary display readings												
	60	61	62	63	64	65	66	67		79		
TA2												
TA3												
TL2												
TL3												
VA	A	A	A	A	A	A		A		A		
VB	B	B	B	B	B	B		B		B		
t3					C	C						
P1					D	D						
P2					E	E						
Customer No.	C	C	C	C	F	F	C	C				
Clock	D	D	D	D	G	G		D				
Date	E	E	E	E	H	H	D	E				
Target date	F	F	F	F	I	I	E	F				
Segment test	G	G	G	G	J	J	F	G		C		

¹⁾ Display of mass will be updated every hour.

Number/letter = Display choice
 1 = First primary reading
 A = First secondary reading

66-B ⇒ 66-CDE
 Info code only displays current conditions. Info code will be reset shortly after the fault has been corrected. While the fault is apparent the hour counter will stop and info hour counter will be activated.

2.3.2 >E< CONFIGURATION OF MULTITARIF
 MULTICAL® Type 66-C and -E have 2 extra energy registers; TA2 and TA3 which can accumulate energy for a programmed tariff condition parallel with the main register. The measuring unit for TA2 and TA3 is always identical to that of the main register (kWh, MWh, GJ or Gcal), but only TA2 and TA3 appear in the unit section.

irrespective of the selected tariff function. The tariff conditions TL2 and TL3 are monitored at each integration for temperature regulated tariffs, and at every 30th second for power and flow controlled tariffs. When the tariff conditions are fulfilled, the amount of thermal energy used will be enumerated in either TA2 or TA3 parallel to the main register.

The main register is always accumulated, as this is considered to be the legal billing register,

2 tariff conditions – TL2 and TL3 – are linked to each tariff function, used in the same tariff type. It is not possible to “mix” the two tariff types.

The table states which tariff types MULTICAL® Type 66-C and -E can be configured to:

E=	TARIFF TYPE	Pil	FUNCTION
0	No tariff active	-	No function
1	Power tariff	7	Energy will be accumulated in TA2 and TA3 based on the flow limits in TL2 and TL3.
2	Flow tariff	8	Energy will be accumulated in TA2 and TA3 based on the flow limits in TL2 and TL3.
3	Cooling tariff	6	Energy will be accumulated in TA2 and TA3 based on the Δt -limits in TL2 and TL3.
4	Not in use	-	No function
5	Return temperature tariff	5	Energy will be accumulated in TA2 and TA3 based on the t_r -limits in TL2 and TL3.
6	TA2= t_f and TA3= t_r , Average per month (TL2 and TL3 are not in use)	-	Average is calculated every 24 hours on the basis of $m3 \cdot t_f$ and $m3 \cdot t_r$. Reset every month on the appointed day and transferred to monthly logger (TA2 and TA3 in the annual logger are set to “0”).
7	TA2= t_f and TA3= t_r , Average per year (TL2 and TL3 are not in use)	-	Average is calculated every 24 hours on the basis of $m3 \cdot t_f$ and $m3 \cdot t_r$. Reset every year on the appointed date and transmitted to the annual logger (TA2 and TA3 in the monthly logger are set to “0”).
9	Time controlled tariff	-	TL2=Start time for TA2 TL3=Start time for TA3
A	PQ-limiter (TA2 and TA3 are not in use)	-	TL2 = Power limit and TL3 = Flow limit. (With just power limitation Q is set at max. and vice versa).

66-B ⇒ 66-CDE

Two of the tariff functions in 66-B, *Bonus numbers and External controlled tariffs*, are not included in 66-CDE.

2.3.2.1 TARIFF TYPES

E=0) NO TARIFF ACTIVE

If the tariff function should not be used, the set up is selected to E=0.

However, the tariff function can later be made active by reconfiguration using METERTOOL for MULTICAL® Type 66-CDE.

See section 7. *Programming via METERTOOL*.

E=1) POWER CONTROLLED TARIFF

When the current heat power (P), in kW or MW, is larger than TL2 but less than TL3, the thermal energy in TA2 is counted parallel to the primary register. If the current power becomes larger than TL3, the thermal energy in TA3 is counted parallel to the primary register.

$P < TL2$	Only counting in the primary register
$TL3 > P > TL2$	Counting in TA2 and in the primary register
$P > TL3$	Counting in TA3 and in the primary register

TL3 must always be set to a higher value than TL2. The power controlled tariff can be used as a basis for the individual heat consumer’s connection fee. In addition this tariff form can give valuable statistical data, when the district heating stations evaluate new plant activities.

E=2) FLOW CONTROLLED TARIFF

When the current water flow (q), in l/h or m³/h, is larger than TL2 but less than TL3, the thermal energy in TA2 is counted parallel to the primary register. If the actual water flow becomes larger than TL3, the thermal energy in TA3 is counted parallel to the main register.

$q < TL2$	Only counted in the primary register
$TL3 > q > TL2$	Counted in TA2 and the primary register
$q > TL3$	Counted in TA3 and the primary register

TL3 must always be set to a higher value than TL2.

The flow controlled tariff can be used as a basis for the individual heat consumer’s connection fee. In addition this tariff form can give valuable statistical data, when the district heating stations evaluating plant activities.

When the power or flow controlled tariff is used, a general survey is given of the total consumption compared to the part of the consumption which is used in excess of the tariff limits.

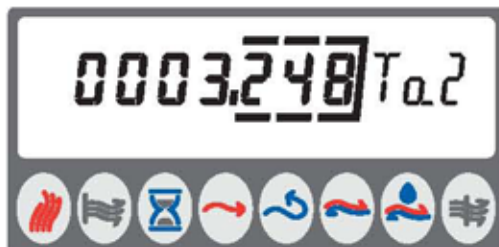
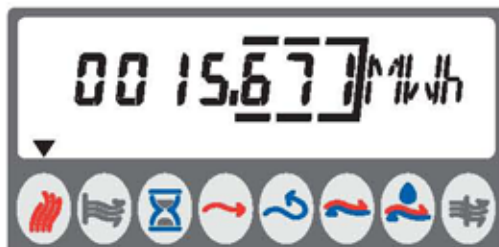

E=3) COOLING TARIFF (Δt)

When the actual cooling (Δt), in °C, is less than TL2, but larger than TL3, the thermal energy in TA2 is counted parallel to the primary register. If the actual cooling drops to less than TL3, the thermal energy in TA3 is counted parallel to the main register.

$\Delta t > TL2$	Counting only in primary register
$TL3 < \Delta t < TL2$	Counting in TA2 and in primary register
$\Delta t < TL3$	Counting in TA3 and in primary register

TL3 must always be set to a lower value than TL2 as shown in below example with TL2=30.00°C and TL3=20.00°C:



The cooling tariff can form the basis of a weighted user payment. A low cooling (small difference between flow and return flow temperature) results in poor economy from the heat supplier's point of view.

E=5) RETURN TEMPERATURE TARIFF

When the current return temperature (t_r), in °C, is larger than TL2 but less than TL3, the thermal energy in TA2 is counted parallel to the main register.

$tR < TL2$	Counting only in main register
$TL3 > tR > TL2$	Counting in TA2 and in main register
$tR > TL3$	Counting in TA3 and in main register

TL3 must always be set to a higher value than TL2. The return temperature tariff can form the basis of a weighted user payment. A high return temperature indicates an inadequate utilization of the heat and thereby a poor economy from the heat supplier's point of view.

E=6) AVERAGE TEMPERATURE PER MONTH

This tariff type does not use TL2 and TL3. For each energy integration the flow temperature (t_f) and the return temperature (t_r) are used in an average calculation which is updated every 24 hours at midnight.

The average calculation covers 1 month at a time and will automatically be reset every month on the target day. The results are stored as monthly data and will be available for 36 months.

Average t_f	$\sum t_f / n$	TA2
Average t_r	$\sum t_r / n$	TA3

The display shows the current month's average temperatures covering t_f and t_r respectively as TA2 and TA3. The display definition is °C without decimals as shown in examples below:



E=7) AVERAGE TEMPERATURE PER YEAR

This tariff type does not use TL2 and TL3. For each energy integration the flow temperature (t_f) and the return temperature (t_r) are put in an average calculation which is updated every 24 hours at midnight.

The average calculations cover 1 year and will automatically be reset every year on the target date. The results are stored as annual data and will be available for 15 years.

Average t_f	$\sum t_f / n$	TA2
Average t_R	$\sum t_R / n$	TA3

The display shows the current year's average temperatures for t_f and t_R respectively as TA2 and TA3. The display definition is °C without decimals as shown in above examples.

E=9) TIME CONTROLLED TARIFF

The time controlled tariff is used to register heat consumption for a particular period. If TL2 = 08.00.00 and TL3 = 16.00.00, the entire day's consumption will be registered in TA2 while the evening's and the night's consumption will be registered in TA3.

TL2 < Clock < TL3	Counting in TA2 and in main register
TL3 < Clock < TL2	Counting in TA3 and in main register

E=A) PQ-LIMITER

When this function is selected MULTICAL® Type 66-C is able to control a motor-operated valve based on the power and flow limits which have been set for TL2 = power limit value and TL3 = flow limit value.

TA2 and TA3 are not in use when the PQ-limiter is selected.

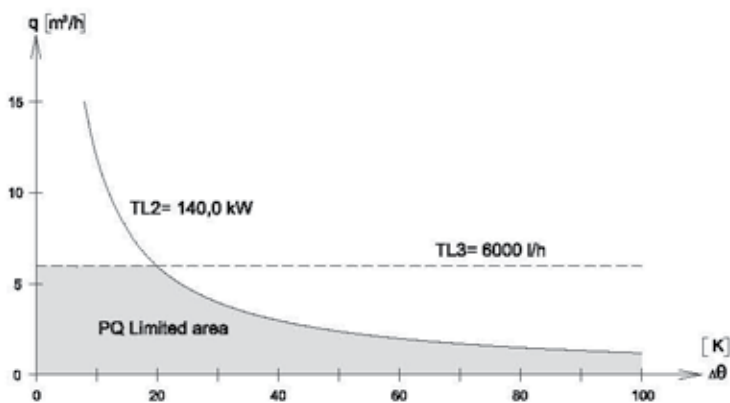

Above diagram shows how the PQ-limiter function ensures that a power limit of 140 kW is not exceeded. In connection with low cooling (e.g. below 20 K) the limiter function also ensures that a flow limit of 6,000 l/h is not exceeded.

If just a power limit is required, the flow limit value TL3 is set to the maximum area q_s of the flow meter and vice versa if just a flow limit is required.

When tariff type E=A is selected the pulse outputs CE and CV are used as UP and DOWN control outputs for a motor-operated valve. The pulse outputs can be used together with following plug-in modules:

- Data/pulse outputs Type: 66-02
- Telephone modem/pulse outputs Type: 66-05
- M-Bus pulse outputs Type: 66-09

The limiter function requires a relatively fast signal from the flow meter, and thereby mechanical flow meters with Reed-contact outputs (CCC=0XX) cannot be used. In addition CONFIG FF and GG have to be set to *outputs* as shown below:

CE output Terminal 16-17		CV output Terminal 18-19	
FF		GG	
00		00	

As the pulse outputs from the meter only are intended for electric signal levels (small circuits and voltages) a Flow Controller module, Type No. S7590006 must be used.

Technical data

Flow Controller, Type No. S7590006

Relay type:	Solid State, galvanically separated
Power supply (8-15):	24 VAC +/- 30%
Motor supply (1-3):	24 VAC
Motor current (1-10-11):	< 1.0 A
Mutual lock-out:	Built-in

Most 24 VAC motor-operated valves on the market can be used.

The motor-operated valve must have a total valve drift of 120...460 sec.

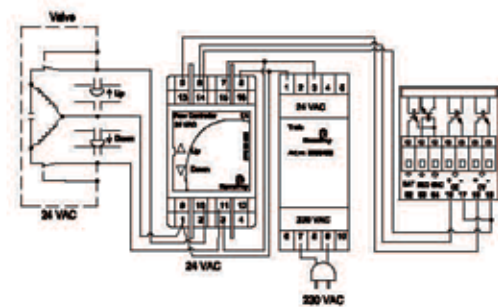

If a motor-operated valve has a spindle velocity of 10 sec./mm and the matching valve a spindle drift of 25 mm, the total valve drift will be 250 sec. Faster motor-operated valves with spindle velocities of e.g. 1...3 sec./mm are generally not suitable for heat systems and cannot be used in connection with MULTICAL® Type 66-C.

The regulation parameters are set to (qp/180 sec) on delivery. When running the PQ-Controller in, the parameters can be changed with MULTITERM or METERTOOL.

Entering tariff limits

When MULTITERM is used for entering tariff limits for MULTICAL® Type 66-C and -E's they must be written as digits and decimals, without decimal points. The temperature tariffs (E=3 and E=5) must always be entered in °C with 2 decimals, whereas the power and flow tariffs (E=1 and E=2) will vary both as regards unit of measurement and number of decimals, depending on the flow meter code (CCC No.) selected.

In addition please note that:

TL3 must be *larger* than TL2 in connection with code E=1, 2, 5, 9 and A.

TL3 must be *less* than TL2 in connection with code E=3 (Δt tariff).

Ex. 1: Δt tariff (E=3)

TL2 = 30.00°C and TL3 = 20.00°C result in:
TL2 = 3000 and TL3 = 2000

Ex. 2: Power tariff (E=1)

TL2 = 10.0 kW and TL3 = 15.0 kW result in:
 TL2 = 100 and TL3 = 150

Ex. 3: PQ-limiter (E=A)

TL2 = 140.0 kW and TL3 = 6000 l/h result in:
 TL2 = 1400 and TL3 = 6000

When using METERTOOL the decimal point is placed by the PC program.

2.3.3 >FF< and >GG< Configuration of extra pulse input and output

In addition to the two flow meter inputs – V1 and V2 – MULTICAL® Type 66-CDE also has 2 additional I/O ports which can be used either as in or output, depending on the configuration.

The >FF< and >GG< codes determine whether the 2 additional I/O ports are used as in or outputs, provided that the plug-in module fits. When I/O ports are used as inputs, the >FF< and >GG< codes also determine pulse separation and resolution.

2.3.3.1 Pulse outputs

The pulse outputs are activated by configuring both FF=00 and GG=00. The I/O ports then function as pulse outputs, where CE (Counter Energy) transmits 1 pulse for the least important digit in the energy display for heat energy, and CV (Counter Volume) transmits 1 pulse for the least important digit in the volume display.

When tariff type E=A is selected the outputs are instead as UP/DOWN control outputs for a motor-operated valve.

The pulse outputs can be used together with following plug-in modules:

- 2 Data/pulse outputs
- 5 Telephone modems/pulse outputs
- 9 M-Bus/pulse outputs
- G Radio/pulse outputs
- H Radio/pulse output external antennae

CE output Terminal 16-17		CV output Terminal 18-19	
FF		GG	
00		00	

2.3.3.2 Pulse inputs

When the two extra I/O ports are set up as pulse inputs, FF and GG can be configured individually. This makes it possible to connect e.g. a water meter and an electricity meter. The register values can be preset via METERTOOL (S/N > 4,047,000).

The pulse inputs can be used together with the following plug-in modules:

- 1 – Data/pulse inputs
- 3 – Telephone modem/pulse inputs + Data
- 4 – M-Bus/pulse inputs
- A – Radio/pulse inputs
- B – Radio/pulse inputs external antennae
- D – 4..20 mA inputs/Data/pulse inputs
- F – LonWorks FTI-10A/pulse inputs
- 8 – M-Bus/pulse inputs

Please refer to section 5. *Plug-in modules* for information pertaining to electrical connections.

Input a Terminal 65-66		Input b Terminal 67-68		Precounter	Wh/pulse	l/pulse	Measuring unit and comma placing	
FF	Max. Input f ≤ 0.5 Hz	GG	Max. Input f ≤ 3.0 Hz					
01	50 m³/h	01	250 m³/h	1	-	100	m³a - m³b	000000.0
02	25 m³/h	02	125 m³/h	2	-	50	m³a - m³b	000000.0
03	12 m³/h	03	60 m³/h	4	-	25	m³a - m³b	000000.0
04	5 m³/h	04	25 m³/h	10	-	10	m³a - m³b	000000.0
05	2.5 m³/h	05	12 m³/h	20	-	5.0	m³a - m³b	000000.0
06	1 m³/h	06	6 m³/h	40	-	2.5	m³a - m³b	000000.0
07	0.5 m³/h	07	2.5 m³/h	100	-	1.0	m³a - m³b	000000.0
24	5 m³/h	24	25 m³/h	1	-	10	m³a - m³b	00000.00
25	2.5 m³/h	25	12 m³/h	2	-	5.0	m³a - m³b	00000.00
26	1 m³/h	26	6 m³/h	4	-	2.5	m³a - m³b	00000.00
27	0.5 m³/h	27	2.5 m³/h	10	-	1.0	m³a - m³b	00000.00
40	500 m³/h	40	2500m³/h	1	-	1000	m³a - m³b	0000000
50	2500 kW			1	1000	-	EL	0000000
51	50 kW			60	16.67	-	EL	0000000
52	40 kW			75	13.33	-	EL	0000000
53	25 kW			120	8.333	-	EL	0000000
54	10 kW			240	4.167	-	EL	0000000
55	8 kW			340	2.941	-	EL	0000000
56	6 kW			480	2.083	-	EL	0000000
57	5 kW			600	1.667	-	EL	0000000
58	2.5 kW			1000	1.000	-	EL	0000000
59	250 kW			10	100	-	EL	0000000

2.3.4 >MN< Configuration of leak limits

District heating leak detection (V1-V2)		Cold water leak detection (VA)	
M=	Sensitivity in leak search	N=	Constant leak at no consumption (Pulse resolution 10 l/imp)
0	OFF	0	OFF
1	1.0% qp + 20% q	1	30 l/h
2	1.0% qp + 10% q	2	20 l/h
3	0.5% qp + 20% q	3	15 l/h
4	0.5% qp + 10% q		

M=2 and N=2 are recommended for single-family houses

2.4 >DATA< for configuration

	Automatically	Order placement	Default on delivery
Serial no./year	e.g. 1000000/2000	-	-
Customer no.	-	11 digits	Customer no.=Serial no.
Target date	-	MM=1-12 and DD=1-28	06.01
TL2	-	5 digits	0
TL3	-	5 digits	0
Peak Avr. time	-	1...1440 min.	60 min.
RS232 data add.	-	Addr. 0...126	Addr. 0
Temp t2, Open system	-	0.00 to 50.00 °C	66C+E = 0.00 °C 66D = 5.00 °C
Max. t1 for cooling measuring	-	0.00 to 40.00 °C	0.00 °C
Date/time	YY.MM.DD/hh.mm.ss GMT+offset acc. delivery code	GMT ±12 hours	-
qp (l/h)	from CCC-table	-	-
Valve drift time, TT	180 sec.	(10...460 sec.)	-
Hysteresis	-	0.5...5 sec.	0.5 sec.
Tel. no. #1	-	Max. 24 digits	-
Tel. no. #2	-	Max. 24 digits	-
Tel. no. #3	-	Max. 16 digits	-

Note! The three phone numbers may consist of max. 48 digits

2.5 Valve specification

General data:

Control function: 3-point-operating contact
 Motor: 24 VAC or 230 VAC
 Characteristic: Linear
 Valve drift: > 240 sec.

Dynamic area:

Power: ps...ps/10 (100...10%)
 Flow: qs...qs/50 (100...2%)

3. Voltage supply

MULTICAL® Type 66-CDE is furnished with two independent supply sources: a back-up battery which is built into the top of the integrator and a primary supply placed in the connecting unit. The primary supply can either be a battery or a supply module

intended for mains supply. Irrespective of which supply type is selected, there will be 3.6 V available internally on the two supply mains, and they should be connected with red 60 (+) and black on 61 (-).

Type number 66 -

<input type="checkbox"/>	-	<input type="checkbox"/>	-	<input type="checkbox"/>	-	<input type="checkbox"/>	-	<input type="checkbox"/>	-	<input type="checkbox"/>	-	<input type="checkbox"/>	<input type="checkbox"/>
--------------------------	---	--------------------------	---	--------------------------	---	--------------------------	---	--------------------------	---	--------------------------	---	--------------------------	--------------------------

Supply module

None	0
D-cell, HiCap lithium battery	2
230 V AC supply module	3
24 V AC/DC supply module	4
24 V DC supply with SO input	5
24 V DC supply with flow meter input	6

Back-up battery

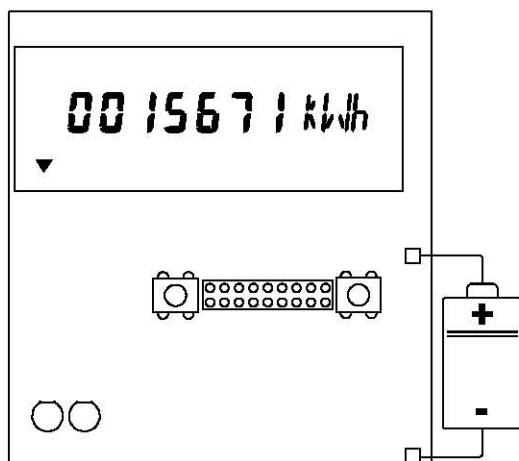

The back-up battery constantly supplies the clock and calendar data as well as data logging functions are reliable. The battery is a lithium type with 3.6 V. Under normal circumstances it has a lifetime of more than 20 years, which gives the back-up cell a lifetime corresponding to 2-4 primary batteries, depending on the selected application (see the following).

If the back-up battery needs to be replaced this must be done with an original spare part, no. 1606-055. If installed in very hot surroundings or if installed for a long time without a primary supply, the lifetime of the back-up cell will be reduced.

Back-up lifetime	
Without a primary supply	2 years
With a primary supply	20 years

D-cell, HiCap lithium battery

When battery is selected as supply for MULTICAL® Type 66-CDE an extremely long lifetime is obtained together with a high degree of reliability. The battery is a 3.6 V D-cell of the Lithium type with an extra high capacity, which in some applications makes it possible to obtain a replacement interval of 10 years. Batteries, type 66-00-200-100 must be used as replacements.

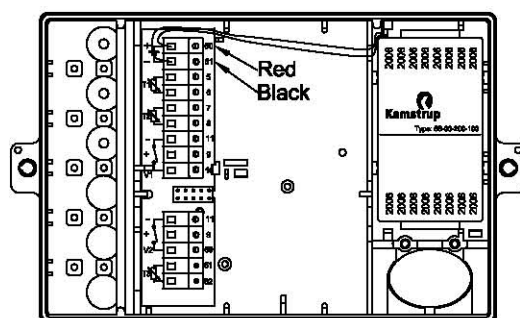

Application	Battery temperature	Battery lifetime
With mechanical flow meter (Reed-switch or electronic pick-up)	< 45°C	10 years
With 1 ULTRAFLOW®	< 45°C	8 years
With 2 ULTRAFLOW®	< 45°C	5 years
With 1 ULTRAFLOW® and wall-mounted MULTICAL®	< 30°C	10 years

Above battery lifetimes apply for standard installation types. When reading data more than once every 24 hours or when placed in very hot places, the battery lifetime will be reduced. When using LON-module and PQ-controller we recommend that MULTICAL® be supplied via mains.

230 VAC

MULTICAL® Type 66-CDE can be supplied directly from the mains supply through a built-in module containing double-chamber safety transformer. The module is constructed to withstand large voltage variations and mains transients. In addition, a built-in Super Cap will ensure that all functions are maintained for up to 5 minutes in case of short-term power cuts.

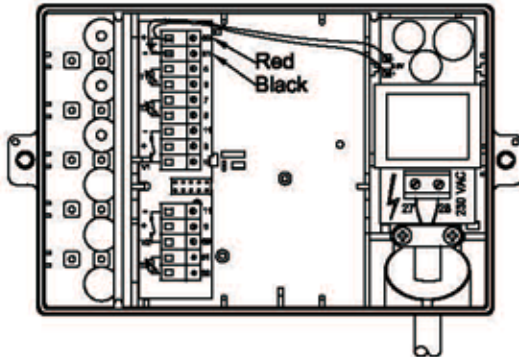

230 VAC mains supply is connected via terminal 27 and 28. No safety ground is used as MULTICAL® with 230 VAC module is doubly isolated.

Mains voltage:	230 VAC +15/-30%
Mains frequency:	48-52 Hz
Power consumption:	< 1W
Reactive power:	< 1VA
Insulating voltage:	4 kV



National regulations for network installation must be obeyed. 230 V modules and 230/-24 V transformer meters must be installed by authorized personnel only. In Denmark installation specifications from "Elråd nr. 5/98" or later edition apply.

24 VAC

MULTICAL® type 66-CDE can be supplied with 24 VAC via an integral module with double-chamber safety transformer. The module is constructed to resist big voltage variations and transients. Furthermore, a built-in SuperCap maintains all functions up to 5 min. in case of power failure.

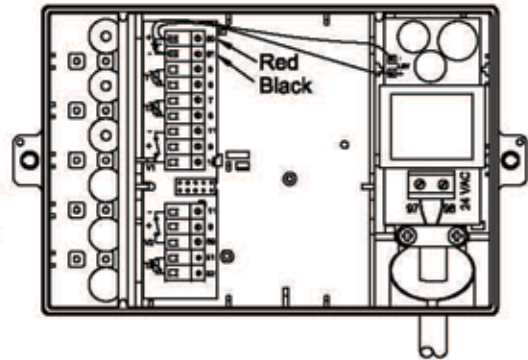

230/24 V trafo for DIN-skinne or panel-mounted can be delivered from No. 66-99-403.

Supply:	24 VAC ±50%
Power input:	< 1.5 W with 230/24 V trafo
Reactive power:	< 2.5 VA
Galvanic isolation:	Via external trafo Type 66-99-403

24 V DC supply with S0 input

This module is used when connecting an active S0 signal from the electricity meters, where input B in MULTICAL® is used as telecounter for the electricity meter. The S0 signal supplies MULTICAL® Type 66-CDE on the same two wires that send pulse signals from the electricity meter. The connection polarity is of no consequence as the module is furnished with a bridge input.

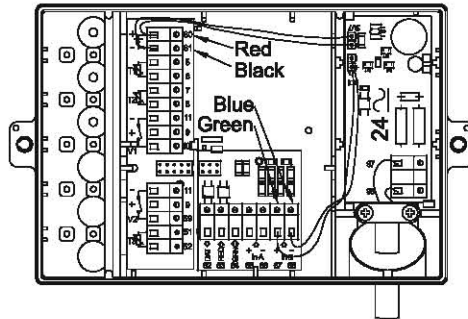

Power consumption: < 1.5 W From active S0 output
Reactive power: < 1.6 VA
Galvanic separation: Via external S0 output

Kamstrup's static electricity meters can be supplied with a built-in S0 supply module, type 68-50-001, whereas mechanical electricity meters must use the S0 converter type 68-30-001. Please contact Kamstrup for further information.

24 V DC supply with flow meter input

This supply module is used when connecting flow meters with active pulse output and negative pulses. Both supply and volume pulses are transmitted through 2 wires, and the connection polarity is of no consequence, as the module is furnished with a bridge input.

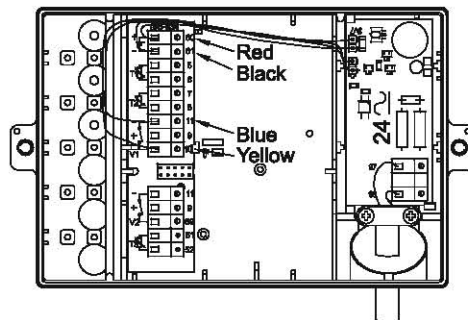

In the intervals between the pulses the output voltage is approx. 24 V, which is used to supply MULTICAL® Type 66-CDE. When a negative pulse appears it is detected by the module which retransmits the pulse to the flow meter input on terminal 10-11.

Pulse voltage: 18- 32 V From flow meter
Pulsating current: < 10 mA with active pulse
Pulse polarity: Negative outputs
Pulse duration: 2-6 msec.
Galvanic isolation: Via flow meter

3.1 Network cables

MULTICAL Type 66-CDE can be supplied with the following cable: (l=1.5 m)

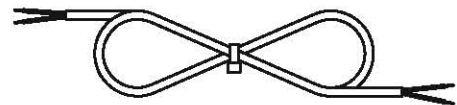

2 x 0.75 mm²

Supply cable, type 5000-286

4. Data communication

MULTICAL® Type 66-CDE has a number of data communication possibilities which enable transmission of all registers, actual values and data loggers from the meter to a PC. In addition, the most important data strings can be transmitted through one of the plug-In modules, as described in section 5.

The communication lines are fundamental:

- Via plug-In modules in the connection unit
- Via an IR-head placed on the front of the meter

Additional data strings can be used by both data/pulse modules as via the IR-head. However, "EN 61 107 data" can only be used via the IR-head.

As MULTICAL® Type 66-CDE controls a large number of different data strings and registers, the following communication description is split up as follows:

- 66-B compatible data
- Specific dataloggers for 66-CDE
- Specific data strings for 66-CDE
- Optical data acquisition

Communication priority

As a type approved energy meter MULTICAL® Type 66-CDE, the meter is of course furnished with a software priority ensuring that data communication cannot effect the energy calculations. When the meters operates with maximum water flow, some request signals may, therefore, be ignored. Furthermore, requests instigated via the Plug-in modules will have higher priority than requests instigated via optical data acquisition.

When compiling software to receive data from MULTICAL® Type 66-CDE, we would recommend request signals always be transmitted a number of times at an interval of min. 5 sec., until data is received.

Transmission speed and format

Communication is based on Ascii characters and is set up as follows:

The response time from request to data is normally 1-2 sec., i.e. response times down to 0.3 sec. can occur in connection with temperature measurements and datalogging.

Request=300 baud and Data=1200 baud.

The signal format is: 1 start bit, 7 data bit, equal parity and 2 stop bit.

The registers are separated by [SP] and each line is ended with [CR].

66-B ⇒ 66-CDE

Data communication in 66-B requires 1 or 2 stop bits, whereas 66-CDE always requires 2 stop bits.

Example of receiving software

When reading data from MULTICAL® Type 66-CDE using the customer's own custom-built software, it is necessary to adapt the PC's communication software.

Except from optical reading, section 4.4, the other data strings neither contain measuring units nor placing of decimals.

Note 1 Information on measuring units and placing of decimals can be seen in the CCC-table in this Technical Description.

Note 2 Every request which is transmitted from the PC to MULTICAL® must be transmitted with 300 Baud, and all data transmitted from MULTICAL® to the PC must be transmitted with 1200 Baud.

Following example of source code shows how this function is implemented.

Example of a communication program in VisualBasic

A "request" for standard data #1 with 300 Baud and receiving data with 1200 Baud.

```
MSComm1.Settings = "300,E,7,2"  
MSComm1.Output = "/#1"  
Delay (10) "Wait to clear output buffer"  
MSComm1.Settings = "1200,E,7,2"  
Temp = MSComm1.Input
```

Contact Kamstrup A/S for further informations.

4.1 66-B compatible data

66-B ⇒ 66-CDE

Following data strings #1...#5 are compatible with similar data strings in MULTICAL® III, Type 66-B, which means that it is possible to use 66-B's plug-In modules and hand-held terminal.

Note! /#4 is amended in the following registers:

66-CDE	Qsum2	Vol2	Pre-counter 1	In-A	In-B	Pre-counter 2
66-B	Water rest 1	Water rest 2	Δt^*k	tF	tR	ABCCC

Additionally, peak registers in 66-CDE only comprise power as opposed to peak registers in 66-B. In the latter it is possible to select power or flow by means of the DD-codes.

Req	STANDARD DATA 1									
/#1	E1-E2	Vol 1	Op. hrs	T1	T2	T1-T2	Power 1	Flow 1	P.pwr act.	Info
	7 ascii	7 ascii	7 ascii	7 ascii	7 ascii	7 ascii	7 ascii	7 ascii	7 ascii	7 ascii

Req	STANDARD DATA 2									
/#2	Cust.no.	TA2	TL2	TA3	TL3	In-A	In-B	ABCCC	DDEFFGG	Date
	11 ascii	7 ascii	7 ascii	7 ascii	7 ascii	7 ascii	7 ascii	7 ascii	7 ascii	7 ascii

Req	TARGET DATA									
/#3	Cust. no.	Target date	E1-E2	Vol1	TA2	TA3	In-A	In-B	P-pwr yr	
	11 ascii	7 ascii	7 ascii	7 ascii	7 ascii	7 ascii	7 ascii	7 ascii	7 ascii	7 ascii

Req	VERIFICATION DATA									
/#4	E1-E2	Qsum1	Qsum2	Vol 1	Vol 2	Pre-counter 1	In-A	In-B	Pre-counter 2	
	7ascii	7ascii	7ascii	7ascii	7ascii	7ascii	7ascii	7ascii	7ascii	7ascii

Req	MONTHLY DATA									
/#5	Cust. no.	Target date	E1-E2	Vol 1	TA2	TA3	In-A	In-B	P.power	
		Target date	E1-E2	Vol1	TA2	TA3	In-A	In-B	P.power	
	11 ascii	7 ascii	7 ascii	7 ascii	7 ascii	7 ascii	7 ascii	7 ascii	7 ascii	7 ascii
	31 months									

4.2 Specific data loggers for 66-CDE

Below dataloggers can be read by the PC program METERTOOL and by the hand-held terminal MULTITERM. However, the latter requires an updated FlashCard.

66-B ⇒ 66-CDE

Following dataloggers are specially designed for MULTICAL® Type 66-CDE and are not supported by plug-in modules and the hand-held terminal, developed for MULTICAL® III, Type 66-B.

Req	DAILY DATA LOGGER											
/#6	Date	E1-E2	Mass1	Mass2	In-A	In-B	P1mid	P2mid	T1mid	T3mid	T2mid	Info_D
	7 ascii	5 ascii	5 ascii	5 ascii	5 ascii	5 ascii	5 ascii	5 ascii	5 ascii	5 ascii	5 ascii	7 ascii
60 days (lines) total, Growth/24-hrs or average values/24-hrs												

Req	HOURLY DATA LOGGER											
/#7	Date	E1-E2	Mass1	Mass2	In-A	In-B	P1mid	P2mid	T1mid	T3mid	T2mid	Info_H
	7 ascii	5 ascii	5 ascii	5 ascii	5 ascii	5 ascii	5 ascii	5 ascii	5 ascii	5 ascii	5 ascii	7 ascii
960 hours (lines) total, Growth/hour or average values/hour												

Req	MONTHLY LOGGER											
/#8	Date	E1-E2	Vol1	TA2	TA3	In-A	In-B	Peff1	Pflow1	Vol2	E_cold	Info_M
	7 ascii	7 ascii	7 ascii	7 ascii	7 ascii	7 ascii	7 ascii	7 ascii	7 ascii	7 ascii	7 ascii	7 ascii
36 months (lines), counter values, monthly peak												

Req	YEARLY LOGGER												
/#9	Dato	E1-E2	Vol1	TA2	TA3	In-A	In-B	Ppwr1X	Pkdate	Pflow1	Vol2	E_cold	Info_Y
	7 ascii	7 ascii	7 ascii	7 ascii	7 ascii	7 ascii	7 ascii	7 ascii	7 ascii	7 ascii	7	7 ascii	7
15 years (lines), counter values, annual peak, date of power peak													

Req	INFO LOGGER			
/#J	Info	Date	Clk	E1_2
	7 ascii	7 ascii	7 ascii	7 ascii
10 lines (events) total				

Req	CURRENT COUNTS											
/#B	E1-E2	E_cold	Vol1	Vol2	Mass1	Mass2	In-A	In-B	TA2	TA3	m3tf	m3tr
	7 ascii	7 ascii	7 ascii	7 ascii	7 ascii	7 ascii	7 ascii	7 ascii	7 ascii	7 ascii	7 ascii	7 ascii
	Current data, counter values											

Req	INSTANTANEOUS VALUES							
/#C	T1	T3	T2	P1	P2	Flow1	Flow2	Power1
	7 ascii	7 ascii	7 ascii	7 ascii	7 ascii	7 ascii	7 ascii	7 ascii
	Programming data, instantaneous values							

Req	PROGRAMMING DATA AND TIMESTAMP							
/#D	Cust. No.	ABCCCCC	DDEFFGGMN	Calendar	Clock	Op. hrs	Target date	Error hr counter
	11 ascii	8 ascii	9 ascii	7 ascii	7 ascii	7 ascii	7 ascii	7 ascii
	Programming data, actual values							

4.3 Data reading

The shown dataloggers can be read by use of PC program METERTOOL LogView (See section 9) or by use of handheld terminal MULTITERM Workabout. (Workabout can not read request # 4, 5, 9, B, C and D).

4.4 EN 61 107, Optical data reading

Following data can only be read through the optical eye placed on the front of MULTICAL® Type 66-CDE.

COMMAND (300BAUD)	RETURN STRING (300BAUD)
/?! [CR] [LF]	/KAM 0 MC [CR] [LF] [STX]0.0(xxxxxxxxxxx) [CR] [LF] 6.8(E1-E2 * enhed) [CR] [LF] 6.26(Vol1 * m3) ! [CR] [LF] 6.31 (Operating hours * h)! [CR] [LF] [ETX] [BCC]

In general, the text is built up according to EN61107/IEC1107, Mode A, but BCC is calculated arithmetically as on M-Bus and not as module 2-binary sum ISO 1155.

Communication is based on ASCII characters with the following setup:

300 baud req /300 baud reply, 1 start bit,
7 data bit, equal parity, 2 stop bit.



Optical reading may not be used with special display codes such as DD=28-36-44, where the first and second display are energy and volume respectively.

5. Plug-in modules

MULTICAL® Type 66-CDE can be supplied with several different plug-in modules, each with their own type of data communication. All data clamps on the modules are galvanically separated from the calculator, which protects the calculator from error functions resulting from eventual transients and similar on the data communication.

All the modules are included in the type tests as well as in the type approval, which means they can be used together with verified energy meters.

Type number 66 -

Plug-in modules

None	0
Data/pulse inputs	1
Data/pulse outputs	2
Telephone modem/pulse inputs + Data	3
M-Bus, EN 1434/pulse inputs MC® III	4
Telephone modem/pulse outputs	5
M-Bus, EN 1434/pulse output MC® III	7
M-Bus, EN 1434/pulse inputs	8
M-Bus, EN 1434/pulse outputs	9
Radio/pulse inputs	A
Radio/pulse inputs external antenne	B
4...20 mA inputs/Data /pulse inputs	D
Analogue output module	E
LonWorks, FTT-10A/pulse inputs	F
Radio/pulse outputs	G
Radio/pulse outputs external antenne	H

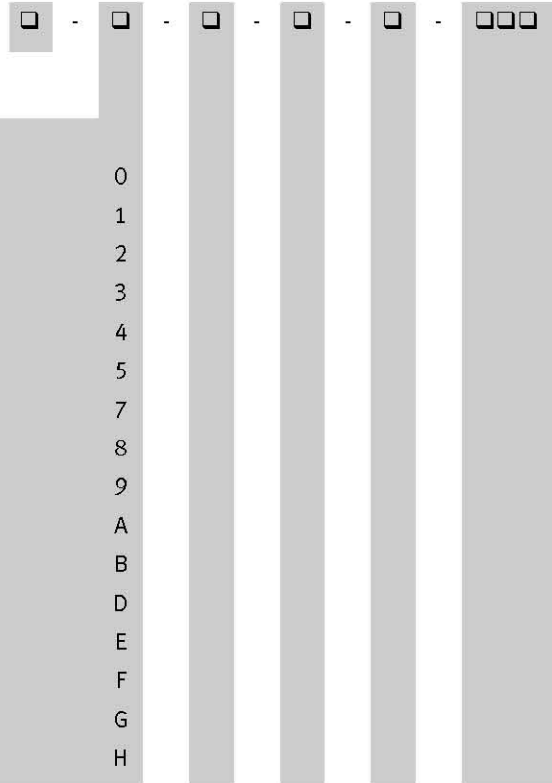

Note! The modules 8-9-D-E are not compatible with MULTICAL® III, type 66-B, but can be used in MULTICAL® 66-CDE.

5.1 Data/pulse inputs

The module comprises data connection, which can be used for external data plug, designed for use with the hand-held terminal MULTITERM, or as a semi-permanent PC connection.

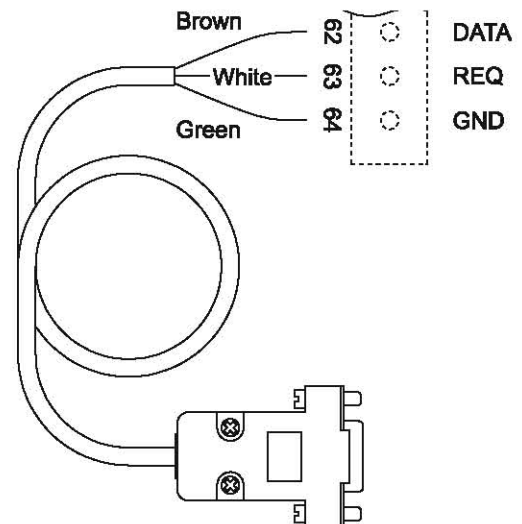
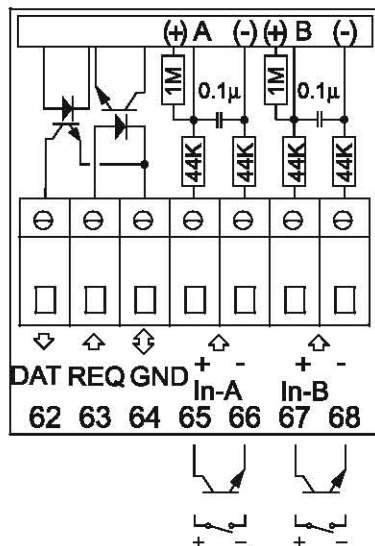

The data connection is galvanically isolated from the optocouplers which makes it necessary to use data cable type 66-99-105 or 66-99-106 in order to adjust the signal to RS-232 level, which is used by PC and MULTITERM. See section 4. *Data communication* for information on data strings and protocols.

If the computer does not have a COM port, a data cable with USB connection, type 66-99-098, can be used.

Two extra pulse signals, e.g. from consumer water and electricity meters can also be connected to the module. Meters with both contact and transistor output can be connected, provided that the leak current in the output is less than 1 μ A.

The pulse inputs can be configured most pulse values, in addition to leak detecting of tap water systems on input A. See section 2.3.3.2 *Pulse input* for information on configuration of pulse values as well as section 2.3.4 *Configuration of leak limits*.

5.2 Data/pulse outputs

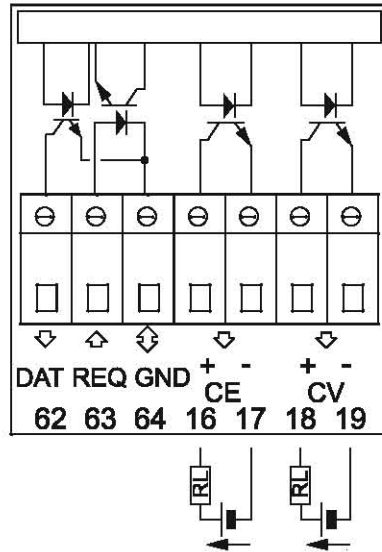

The data connection in this module is identical to that described earlier.

The module can also transmit energy and volume pulses to CTS-systems or similar remote accumulation. The pulse outputs are convenient for connecting electronic counter inputs, while electromechanical counters normally needs higher current and pulse duration.

Every time the energy and volume display is updated, one pulse on respectively the CE and CV outputs is transmitted (CE only heat energy).

Example: CCC=119 causes 1 kWh/puls and 0.01 m³/pulse

Voltage: < 30 V
Load: < 10 mA
Pulse duration: = 32 msec.

The pulse outputs can also be used as UP/DOWN control signals, when MULTICAL® Type 66-C is used as PQ-controller. See tariff type "E=A" in section 2.3.2.1 *Tariff types* for further information on the PQ-controller function.

5.2.1 Pulse extension

If a pulse duration of more than 32 msec. is required, a data/pulse module type S7590007 can be used.

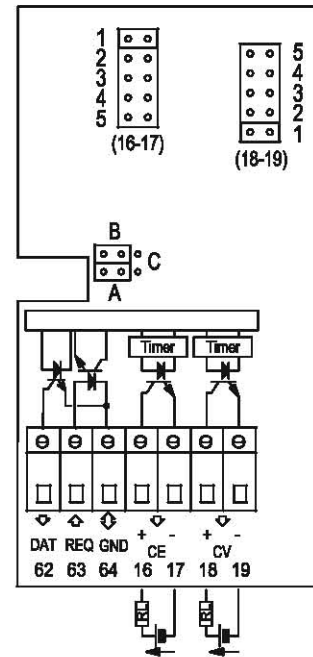

Voltage: < 30V
Load: < 10mA
Pulse duration: 0.125 - 2 sec.
(jumper setting)

JP	Pulse duration sec.
1	0.125
2	0.25
3	0.5
4	1
5	2

! When 79-64-440 is used in MULTICAL® the battery lifetime will be reduced by 1-2 years

Jumper setting	Output 16 - 17	Output 18 - 19
A + B 	Energy	Vol.
A + C 	Energy	Energy
B + C 	Vol.	Vol.

5.3 Telephone modem/pulse inputs

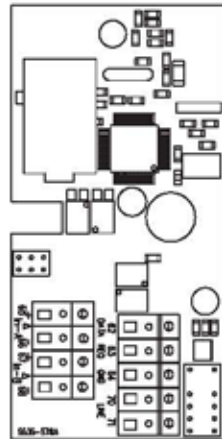

For further information, please see the Technical Description for Modem, 5511-713. The pulse inputs in this module are identical to those described earlier.

5.6 4...20 mA inputs/Data /pulse inputs

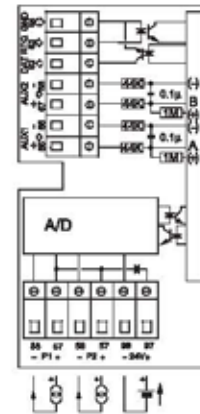

The data connection and the pulse inputs in this module are identical with those described earlier.

The module makes it possible to connect two pressure transmitters to MULTICAL® Type 66-CDE. This function is primarily intended to monitor water pressure in the flow- and return pipes, with respect to datalogging and display readings.

The module requires a 24 VDC voltage supply, which is connected on clamp 97(+) and 98(-).

The two pressure transmitters, for measurement of P1 and P2, are connected to clamps 57(+) and 58(-) respectively clamps 59(+) and 59(-).

The pressure can be selected individually for P1 and P2 – please see table on next page – by means of the 8-poled DIP-switch on the printed circuit board.

5.4 M-Bus, EN 1434/pulse inputs

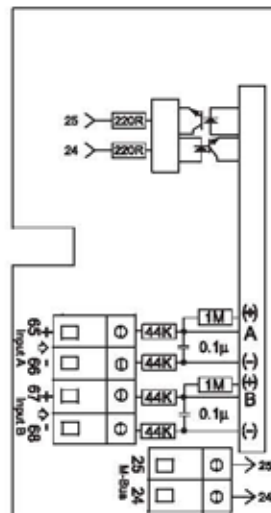

For further information on M-Bus, please see Technical Description for M-Bus, 5511-710. The pulse inputs in this module are identical with those described earlier.

P1 (P2)				Area
1 (5)	2 (6)	3 (7)	4 (8)	
OFF	OFF	OFF	OFF	mA (Test)
ON	OFF	OFF	OFF	1 bar
OFF	ON	OFF	OFF	6 bar
OFF	OFF	ON	OFF	10 bar
OFF	OFF	OFF	ON	16 bar
OFF	OFF	ON	ON	25 bar
ON	ON	ON	ON	40 bar

5.5 Telephone modem/pulse output

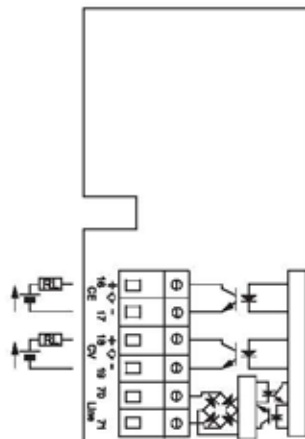

Modem and pulse outputs in this module are identical with those described earlier.

E.g.: Two pressure transmitters are installed with measuring range 0-16 bar and output of 4...20 mA. DIP-switch 4 and 8 must be **ON**, the rest must be **OFF**.

Irrespective of the measuring range selected, the measured pressure will be shown with two decimal places on the display and in the data logger. The display values are updated approx. every 10th minute.





If all DIP-switches are OFF, the meter will change to test-mode, where the display for P1 and P2 is up-dated at 2-4 sec. intervals and the measured mA value is shown directly on the display – with [Bar] as the measuring unit. This function is used e.g. when the pressure transmitters' zero point (4 mA) has to be monitored or adjusted, together with module control.

After 2 hours in this test-mode the module automatically increases the interval up to 10 minutes in order to reduce the meter's power consumption.

Technical data:

Supply voltage:	18 - 32 VDC, max. 70 mA
Transmitter inputs:	4...20 mA
Test-mode:	3.9 - 24 mA range
Input resistance:	< 250 Ohm (< 5 V @ 20 mA)
Accuracy:	±0.75% of chosen measuring area, without adjustment.
Demands for pressure transmitters:	4...20 mA, 2-wire Loop voltage < 18 V @ 24 V supply

Recommended voltage supply (DIN rail can be mounted): Bourdon Haenni, type 89-13-313.

5.7 LonWorks, FTI-10A/pulse inputs/outputs

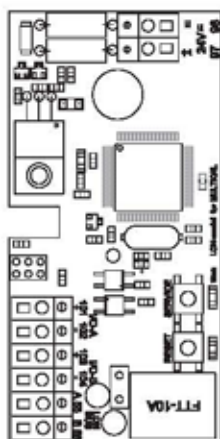

Inputs/outputs (I/O) are configured automatically from the MULTICAL® setup. At pulse inputs both "FF" and "GG" codes must be different from "00". For further information on the LonWorks module, please refer to the Installation guide S7210-038 or Technical Description of LonWorks S7220-064.

Pulse inputs/outputs in this module are identical to those described earlier.

5.8 M-Bus – EN 1434/pulse outputs

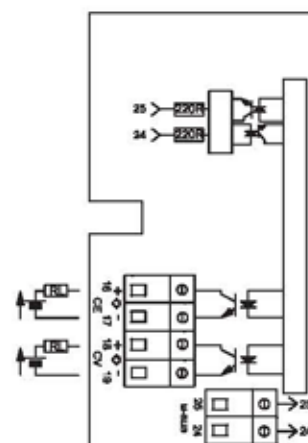

For further information on M-Bus, please refer to *Technical Description for M-Bus (5511-710)*.

The pulse inputs in this module are identical with those previously described.

5.9 Analogue output module

The analogue output module can either be placed in the modular space in MULTICAL® type 66-CDE, 66-MP and 66-ST, or it can be used for ULTRAFLOW® in connection with a pulse transmitter.

The module is furnished with two active analogue outputs, which can both be configured for 0...20 mA or for 4...20 mA. In addition, the outputs can be configured to any measuring value (power, flow or temperature) and to any range scaling.

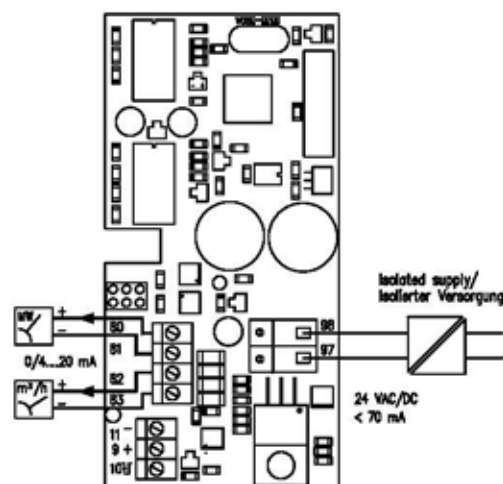

Furthermore, the module can be connected to an .External Communication Unit. type S7590-032 via a 3-wire data connection, which must be connected to a data module in MULTICAL®. In this way, e.g. pulse outputs and analogue outputs can be used from the same MULTICAL®.

The module is configured via Kamstrup PC program METERTOOL – see section 7.10.

5.10 Radio/Pulse inputs/outputs

The radio module is used for wireless communication within a licence-free radio band and is available with internal antenna or external antenna connection. For further information please refer to *Technical Description of radio (5512-013)*.

Pulse inputs/outputs in this module are identical to those described earlier.

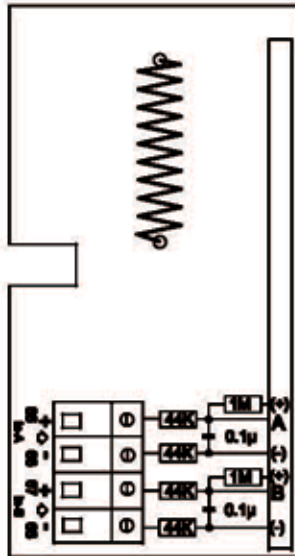

5.11 Data cables

MULTICAL® type 66-CDE can be supplied with one of following cables: (1.8 m)

- Data cable with 6PC module plug, type 66-99-125
- Data cable with 8PC module plug, type 66-99-127
- Telephone cable with dk plug, type 66-99-126

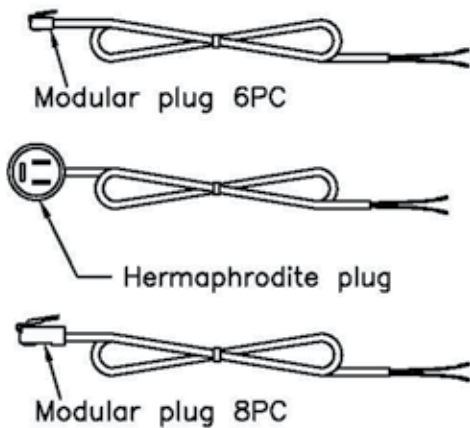

6. Printing logged data

As described in section 4.2 *Specific datalogger for 66-CDE*, the calculator includes a number of dataloggers which are updated at different intervals. All dataloggers can be transmitted to a PC or a hand-held terminal. Additionally, the hour and 24-hour loggers can also be printed by means of the IR head with 25 poled plug for printer (type 66-99-107).

The serial printer can be EPSON LX300 or similar. Before connecting the printer must be adjusted for following parameters:

Data format 1200 Baud - 7 data bit - EVEN parity - 2 stop bit

Mark format 96 characters per. line

The print is activated by pressing the right push button until 001 PRT for hour data or 002 PRT for 24 hour data are displayed. Then you must press both buttons simultaneously and printing will begin.

If you need to abort the print, one of the push buttons must be activated.

001 PRT Hour data

Is used when a print showing hourly intervals for the preceding 40 days is required. The print is very detailed and is therefore a good basis for diagnostic testing.

Please note that the print takes approx. 15 minutes for all 960 lines.

Req													
Push-button	Esc codes for printer												
	MULTICAL 66-D C/N xxxxxxxxxxxx												
	Print date xxxxxxxx												
*1	Free text												
		MWh	Ton- 1	Ton- 2	M3- a	M3-b	Bar-1	Bar-2	C- T1	C -T3	C -T2	Info	
	*	0.001	0.01	0.01	0.1	0.1	0.001	0.001	0.01	0.01	0.01		
	990122	23-24	Xxxxx	Xxxxx	Xxxxx	Xxxxx	Xxxxx	Xxxxx	Xxxxx	Xxxxx	Xxxxx	Xxxxxxx	
	990121												
	960 lines of hourly data (terminated by pressing the button)												

002 PRT 24 hourly data

Is used when a print of last month's consumption is required. 24 hour data is controlled by the meter's target date and the desired account date can be chosen in the configuration.

Req													
Push-button	Esc code for printer												
	MULTICAL 66-D C/N xxxxxxxxxxxx												
	Print date xxxxxxxx												
*2	Free text												
		Mwh	Ton- 1	Ton- 2	M3- a	M3- b	Bar-1	Bar-2	C- T1	C -T3	C -T2	Info	
	*	0.001	0.01	0.01	0.1	0.1	0.001	0.001	0.01	0.01	0.01		
	990122	00-24	Xxxxx	Xxxxx	Xxxxx	Xxxxx	Xxxxx	Xxxxx	Xxxxx	Xxxxx	Xxxxx	Xxxxxxx	
	990121	00-24											
	Total month's consumption												
	28-31 lines 24-hour data (terminated by pressing the button)												
	Info-log												
	10 lines												



If you make a print of the preceding month's consumption data, the results for the last two 24-hour periods will be incorrect.

E.g. If the target date is programmed to 20th January [01.20], the monthly print-out will cover from 20/M to 19/M+1. This print will be available from 20/M+1 until 18/M+2.

Parallel printer

If a printer furnished with Centronics interface is to be used, an adapter is required, e.g. MAXXTRO CVTSP2.

Remember to supply the adapter with 9 VDC.

7. Programming via METERTOOL

Introduction

METER TOOL for MULTICAL® Type 66-CDE is a Windows software, which can be installed on a PC and used to program and verify the calculator. METER TOOL is developed with a view to offering distributors, heating plants and laboratories a simple and effective access to programming and verification of the integrator.

7.1 PC and printer requirements

METER TOOL is suitable for installation under Windows 95/98/NT/2000/XP on Pentium based PCs with at least 16 MB RAM, 20 MB free hard disk and VGA monitor min. 640 x 480. Recommended 800 x 600 or higher.

In order to be able to install the program, the PC must be supplied with a 680 MB CD-drive.

To facilitate programming of MULTICAL® Type 66-CDE, serial data connection (COM-port) between the calculator and PC is used. An IR head type 66-99-102 can be used for configuration. If verification equipment type 66-99-28x is used both programming and verification can be made.

With all types of connection, the program can be set up to use the PC's COM1...8.

The program can meanwhile be used for printing labels for MULTICAL® Type 66-CDE. The printer must be compatible with Windows and be suitable for printing small self-adhesive label sheets.

The printer is connected to the computer's parallel port, LPT1.

Kamstrup A/S recommends e.g. an OKI 610ex, OKI 410ex or a HP4 laser printer, but other printer types can also be used.

Sheets with original self-adhesive labels, type 2008-259, can be ordered from Kamstrup A/S.

7.2 Installation of software

Please check that the computer has min. 20 MB free space on the hard disk, e.g. by means of Windows File Manager. Close all active Windows programs before installing the program.

Insert the CD in the drive and follow the program's instructions as they appear on your screen.

When the installation is completed, the icon "METER TOOL" will appear in the Start menu. Double click on the new icon "METER TOOL" to start the program.

Please note: If the right printer driver is not installed, the program will not be able to print labels or certificates.

7.3 Connecting MULTICAL® Type 66-CDE to PC

The calculator is programmed for serial data transmission between the calculator and the computer. The data can be transmitted by means of optical IR head type 66-99-102 or verification equipment, e.g. type 66-99-284.

Optical IR head type 66-99-102

The optical head is placed between the two pins on the front of the calculator where it is held in place by means of a magnet. The IR head cable must always point downward $\pm 20^\circ$. The optical IR head MUST NOT be used or stored near diskettes or computers as the magnet can damage the data. Always cover the magnet with the protection plate when it is not in use.



The optical head, combined with a lap-top computer is the ideal way to program the meter. E.g. new tariff limits can be programmed quickly and simply on site without removing the energy meter. If MULTICAL® Type 66-CDE is furnished with a plug-in communication module, e.g. M-Bus or LonWorks, programming via the optical head may be non-functional. In these cases, we would recommend that you use the verification equipment for the task.

If the computer has a 25-pole COM-plug, a 9M/25F adapter, type 66-99-120 must be used.

Verification equipment type 66-99-28x

See section 8. *Verification via METER TOOL* for further information.

If the computer does not have a COM port, optical head with USB connection, type 66-99-099, can be used.

Connect the serial data communication as described in previous paragraph and start the program by clicking on the icon "METER TOOL". Choose the button "Read meter" and data will be transmitted from the meter and shown on the monitor.

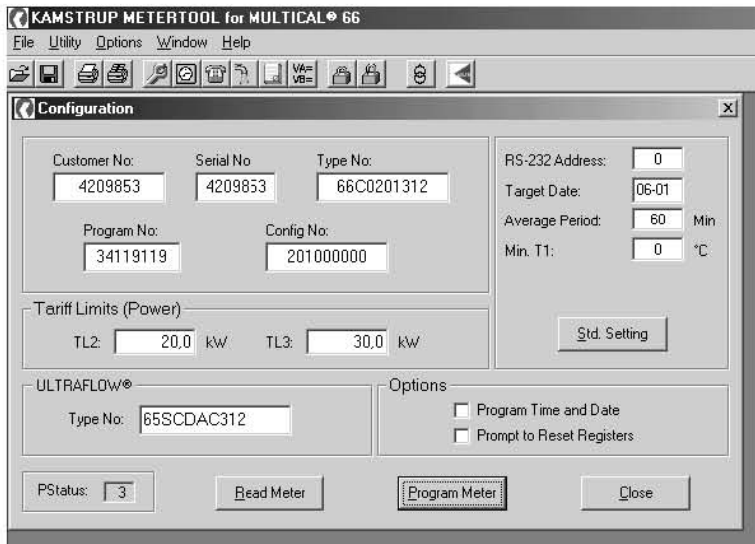

7.4 Programming

It is important that you are familiar with all calculator functions before programming.

All necessary information appear in this Technical description.

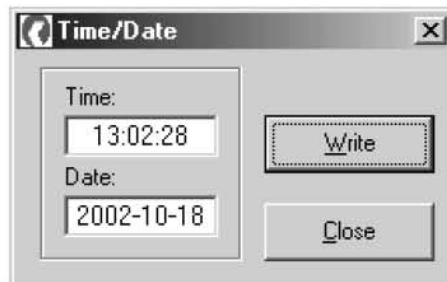

Furthermore, you must check the computer's internal clock before programming – date and time will be transmitted from the PC to the calculator when you program "Time/Date".

7.4.1 Partial programming

If the programming lock in MULTICAL® Type 66-CDE (indicated by a ring in the diagram below) is open, the meter can only be partially programmed.

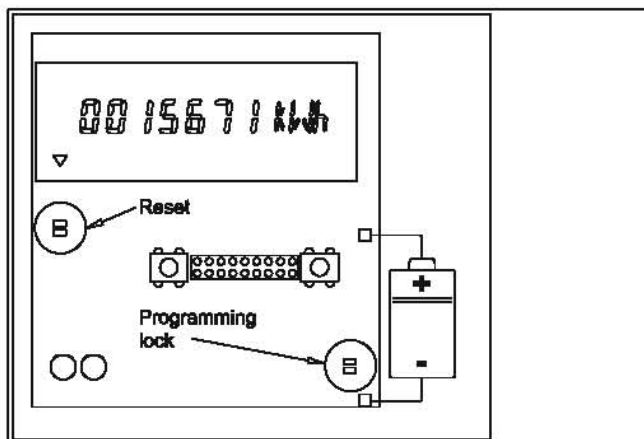

The limitation means that the legal parameters A-B-CCC-CCC and type and serial No. cannot be changed, while all other data can be programmed as required. This limitation is used to prevent the original operating parameters from being changed on type approved and verified meters.

National verification demands must be checked before the integrator's verification seal is broken.

7.4.2 Complete programming

If the programming lock is short-circuited, it is possible to reprogram MULTICAL® Type 66-CDE, incl. the legal data A-B-CCC-CCC and type- and serial No.

For security reasons, a soldering iron should not be used to short-circuit the programming lock.

Instead, please use the original short-circuit pen, type 66-99-278, which can be ordered from Kamstrup A/S.

Please note that the data logging memory in the calculator can not be changed/erased during programming, unless this is selected in the software.

7.5 File

Under the menu "File" one of the following functions can be selected:

- Open Customer** Fetch stored customer settings from the data base.
- Save Customer** Save new customer settings in the data base.
- Print Setup** Printer setup for printing front label and certificate.
- Print Label** Starts print of front label.
- Print Certificate** Starts print of test certificate.
- Exit** Terminates METERTOOL.

7.6 Utility

This menu gives access to the following dialog boxes:

- Configuration** General view which is used when reading and programming.
- Time/Date** The PC's date and time is transmitted to MULTICAL®.
- Telephone No.** 3 different telephone numbers can be programmed in MULTICAL®.
- PQ Controller data** Is used to change regulating parameters.
- Log printer settings** Setting of MULTICAL®'s own printer control.
- Preset VA/YB** Used to preset the register values for the 2 additional pulse inputs for water and electricity meters.
- Info Codes** Is used for reading the latest 10 Info-codes.
- Meter type** Reads the internal software revision of the meter.
- Reset dataloggers** Resets all dataloggers if the programming lock is short-circuited.
- Verification** See section 8. *Verification via METERTOOL.*

	Info	Date	Time	E1_2 [MWh]
1	8	00-11-06	14:17:14	2,199
2	9	00-11-06	14:20:20	2,225
3	13	00-11-06	14:30:00	2,225
4	12	00-11-06	15:46:20	2,225
5	8	00-11-06	15:46:20	2,225
6	12	00-11-06	15:50:20	2,249
7	13	00-11-06	15:50:30	2,249
8	12	00-11-06	15:50:40	2,249
9	4	00-11-06	15:50:40	2,249
10	0	00-11-06	15:50:40	2,249

7.7 Options

The menu has a few settings which are not used very often:

- Programming** Setting of partial or total programming.
- Verification data** See section 8. *Verification via METERTOOL.*
- ComPort** Indicates the choice of Com1...8.

7.8 Windows

This function makes it possible to switch between open dialogue boxes.

7.9 Help

- Online help F1: offers description of the program functions.
- About: Provides information about program numbers and revisions in the METERTOOL® program.

7.10 Supplementary programs

Configuration is made via Kamstrup's PC program METERTOOL type 66-99-702. The data connection between the PC and the analogue module is made via the interface cable type 66-99-140.

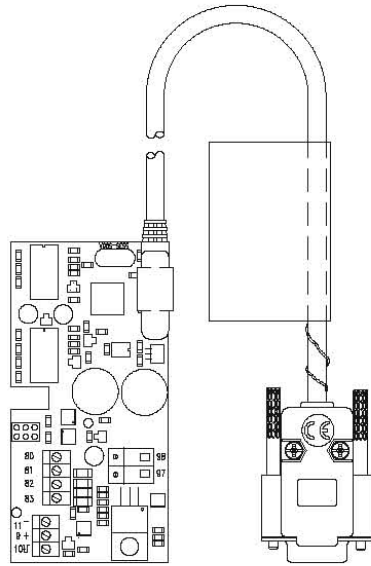

Select the program METERTOOL for MULTICAL® 66 and afterwards select the function in the upper toolbar.



When the interface cable is connected to the module test plug, select "Read" in the program, and the actual configuration will be shown in the display.

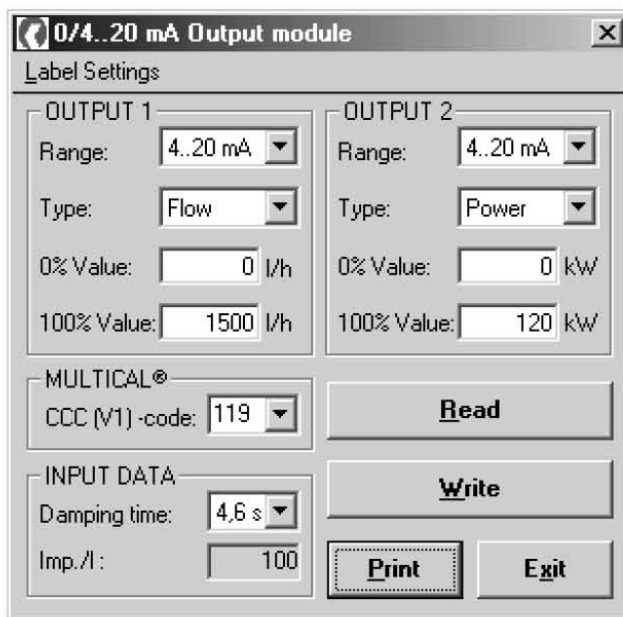

Enter the changes and transfer them to the module by activating the "Write" key.

- Output:** Select between 0-20 mA or 4-20 mA. The outputs are selected individually.
- Type:** Select input source for each of the two outputs. "Pulseinput" can only be selected, if a flow meter is connected to the terminal 11-9-10 of the module.
- 0% value:** Indicates the measuring value at 0 mA and 4 mA, respectively.
- 100% value:** Indicates the measuring value at 20 mA. The value must be higher than the indicated measuring value for 0%.
- CCC-code:** Must always be stated.
- Damping time:** Only state, when a flow sensor is connected to terminal 11-9-10 of the module.
- Imp/l:** The pulse value is automatically shown based on the selected CCC-code.

7.11 Delta program

The Delta program provides the possibility of calculating true energy with compensation of the k-factor.

8. Verification via METERTOOL

Equipment description

Verification equipment type 66-99-28x is used for testing and verifying the MULTICAL® Type 66-CDE calculator. The test includes volume simulation of up to four flow meter inputs, ie. V1 - V2 - VA and VB.

Different temperatures for all three sensor inputs, T1 - T2 - T3, are simulated and, together with the volume simulation, form the basis of verification of the energy calculation.

The equipment is primarily designed for use in laboratories which test and verify energy meters, but it can also be used to test meter operation.

The computer program METERTOOL type 66-99-702 is used to configure, test and verify.

All data communication between the computer and the integrator is transmitted via the computer's serial ports; COM1...4, which are connected to the verification equipment. Please note that the equipment must be supplied via the associate mains adaptor.

The computer must comply with demands specified in section 7. *Programming via METERTOOL*.

Verification does not include temperature sensors and the flow part.



The verification equipment is supplied in 3 different types, depending on which MULTICAL® type is applied as well as the temperature points which are to be tested.

66-99-284 Standard (EN 1434) Type 66-C	T1 [°C]	T2 [°C]	T3 [°C]
	160	20	-
	80	60	-
66-99-285 Closed systems Type 66-C and 66-E	T1 [°C]	T2 [°C]	T3 [°C]
	160	10	-
	80	60	-
66-99-286 Open systems Type 66-D	T1 [°C]	T2 [°C]	T3 [°C]
	160	5	10
	80	5	60
	43	5	40

8.1 Function

Verification equipment type 66-99-28x is mounted in a standard MULTICAL® base and contains battery, connection print, verification print, microprocessor, control relays and precision resistors.

The calculator can be mounted on this base quite simply.

During the test the calculator is supplied by the battery. The verification print is supplied via the associate external mains adaptor with 12 V DC. The microprocessor simulates the volume based on pulse frequency and the number of pulses per test point, which have been selected in the computer program. Temperature is simulated by means of permanent precision resistors which are changed automatically via relays controlled by the microprocessor.

After testing the computer reads all registers in the calculator and compares the values with the calculated values.

Deviation, determined for each test point – shown as a percentage – can be printed on a test certificate or stored in the computer under the serial number of the tested MULTICAL®.

8.2 Verification data

The first time that METERTOOL and the verification equipment are used, a number of calibration data must be entered in the menu "Verification data". As these data are of crucial importance for the verification result, they are protected by a password which can only be disclosed by Kamstrup A/S.

Permissible Error		Uncertainty	
1st	1.5 %	1st	0.3 %
2nd	0.6 %	2nd	0.2 %
3rd	0.5 %	3rd	0.1 %

Heat Coefficients	
Flow Pipe	
1st	4.1403 MJ / (m³°C)
2nd	4.0715 MJ / (m³°C)
3rd	3.8313 MJ / (m³°C)
Return Pipe	
1st	4.1458 MJ / (m³°C)
2nd	4.119 MJ / (m³°C)
3rd	4.2147 MJ / (m³°C)

Verification Hardware	
No:	539832

Test Points			
	Measured Resistance	True Temperature	Nominal Temperature
1st Tf	584.138 Ohm	43.333 °C	43 °C
1st Tr	577.691 Ohm	39.993 °C	40 °C
2nd Tf	654.011 Ohm	79.752 °C	80 °C
2nd Tr	616.193 Ohm	59.991 °C	60 °C
3rd Tf	804.752 Ohm	159.721 °C	160 °C
3rd Tr	538.97 Ohm	20.001 °C	20 °C

Number of Integrations		
1st	5	2nd 2
		3rd 1

Meter Type	
Type 66-C	<input type="radio"/>
Type 66-D	<input type="radio"/>
Type 66-E	<input type="radio"/>
Type 66-M/P	<input type="radio"/>
Type 66-S/T	<input type="radio"/>

Permissible error and uncertainty

Max. permissible error, indicated as a percentage, and the equipment's measuring uncertainty must be indicated under each of the three verification points; 1st, 2nd and 3rd. The "permitted error" minus "uncertainty" will be indicated as MPE on the verification certificate. According to EN 1434 is $MPE \pm(0,5 + \Delta\theta \text{ min}/\Delta\theta)\%$.

Heat coefficient in flow and return

When the calibration values for the temperature simulators are entered in the program, it automatically calculates the true k-factor, according to the formula in EN 1434.

Test points

The test points 1st, 2nd and 3rd are determined by the size of the temperature simulation resistances fitted in the test equipment. The rated temperature points are indicated in the preceding paragraph.

Measured resistance

In order to update the temperature simulators' calibration, the temperature resistances' latest measured resistance values are entered. A calibration sheet with declaration of measured resistance values for all simulators is supplied by Kamstrup A/S together with the verification equipment. The temperature simulators must be calibrated at Kamstrup A/S once a year.

Enter number of integrations

Enter the number of integrations required at each test point in this field. If the programming number is e.g. A-B-119-119 (corresponding to ULTRAFLOW® II, qp 1.5 m³/h), 1000 volume pulses must be received for each integration corresponding to 0.01 m³. In case of doubt please see the CCC table in section 2.2.1.

8.3 Verification

All necessary information can be transmitted directly from the calculator via serial data transmission, which simplifies verification. Before test or verification can be started, a control must be made to confirm that all verification data are correct. The procedure is started by clicking on "Start test".

The test takes between one and five minutes depending on the test type selected and the size of the meter.

When the test is completed, the results are shown on the monitor. If the results can be approved, click on "Save" and all verification data will be stored in the data base under the calculator serial number. It is possible to save data both on verification and control.

If a printed certificate with the test results is desired, select "Print" from the "File" menu.

The field "Test Type" is used for selecting either combined verification and volume test, separate volume test or verification. When verifying MULTICAL® Type 66-C with only one water meter connected (V1), separate verification can be selected and the test duration is reduced.

If the time consumption of a test is uncritical, we recommend that a combined verification and volume test always be selected as all inputs are then tested.

8.4 Maintenance

Verification equipment type 66-99-28x is designed to work a number of years with a minimum of maintenance. The following must, however, be executed frequently in order to secure optimal operation:

Recalibration

On delivery, a calibration certificate is enclosed issued by Kamstrup A/S. The applied calibrated resistance values must be entered under "Verification data". The equipment must be recalibrated at least once a year.

Change of connection print

The connection print (in the left side of the unit) must be changed with regular intervals as the connection pins for the calculator top will wear down in time – depending on how often it is applied. Under normal circumstances the print should be replaced for every 500 verified calculators (Type 5550-492).

The screenshot shows the 'Verification' software interface. It is divided into several sections:

- Heat Meter Data:** Fields for Date Of Test (2002-10-21), Manufacturer (Kamstrup A/S), Serial No. (4209853), Customer No. (4209853), Program No. (3-4-119-119), Config No. (20-1-00-00-00), and Type No. (66-CD-201-312).
- Test Type:** Radio buttons for 'Verification and Volume Test' (selected), 'Energy Verification', and 'Volume Test'.
- Buttons:** 'Save...' and 'Start Test' buttons.
- Verification Of Heat Energy:** A table showing results for three test points (1st, 2nd, 3rd) across four categories: True Vol., True Tf, True Tr, and True Quick. Below this is a summary table for Quick, Error %, and MPE ± % for each point, with 'Passed' status.
- Volume Test:** A table showing 'Test Initial' and 'Test End' values for Vol. V1, Vol. V2, Vol. A, and Vol. B, with 'Passed' status.
- Test Conditions:** A table showing 'Test Initial' and 'Test End' values for Energy (MWh) and Vol. V1 (m³).
- Close:** A button at the bottom center.

CERTIFICATE OF CALIBRATION

Verification Equipment for MULTICAL[®]

Customer: **Kamstrup A/S, Industrivej 28, DK-8660 Skanderborg, Denmark**

Type No.: **66-99-286**

Type of Multical[®]: **66-D**

Serial No.: **998877**

Procedure: Kamstrup A/S No.: 5509-405 QI

Test equipment:

DMM, Datron 1271, Kamstrup A/S No.: 14-021-010

Standard Resistor, Vishay RTB 10, Kamstrup A/S No.: 14-061-020

This certificate provides traceability of measurement to recognised national/international standards

Expanded Uncertainty: ± 15 ppm

(Coverage factor $k=2$)

Measurements:

		Nominal temperature [°C]	Nominal resistance [ohm] *	Measured resistance [ohm]	Calculated temperature [°C] *
1st	T1	43	583.495	583.456	42.980
	T2	5	509.764	509.822	5.030
	T3	40	577.704	577.611	39.952
2nd	T1	80	654.484	654.299	79.903
	T2	5	509.764	509.822	5.030
	T3	60	616.210	616.255	60.024
3rd	T1	160	805.272	805.134	159.926
	T2	5	509.764	509.822	5.030
	T3	10	519.513	519.688	10.090

* According to IEC 751/EN 60751 Amendment 2, 1995-07 "Industrial platinum resistance thermometer sensors"

Date: **1999-09-03**

Calibrated by: **JLH**

Tamb.: **23.2 °C**

Kamstrup A/S - Industrivej 28 - DK-8660 Skanderborg - Denmark

5509-491 FM, Rev.:A1

Have you lost your certificate?
Call Kamstrup and state No. and S/N of the equipment, and we will send you a new certificate.

9. Data reading with METERTOOL LogView

Introduction

METERTOOL LogView (Part no. 6699703) is a Windows software, that makes it possible to read data from Kamstrup meter types MAXICAL III, MULTICAL®, MULTICAL® Compact and MULTICAL® III.

Data will be processed according to the meter configuration and will be presented with comma-placing and units.

Requirements, installation and connection are identical with those stated in paragraph 7.1 - 7.3

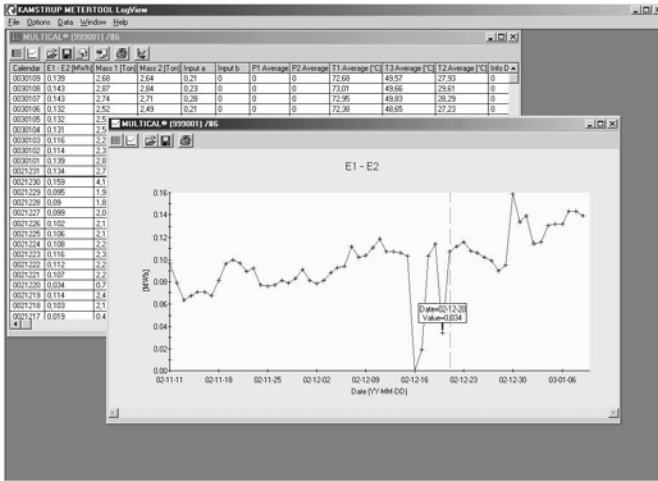

9.1 File

Under the "File" menu one of below functions can be selected:

- Open Retrieve stored data records
- Save As Save reading data
- Send to Send data as an HTML file on e-mail
- Add comments To be used in cases where the text should be added to the table
- Print Start printing the table
- Page Settings Set up margins and paper format

9.2 Command

Select the Kamstrup meter type to be read and the required reading (see paragraph 4 for optional data).

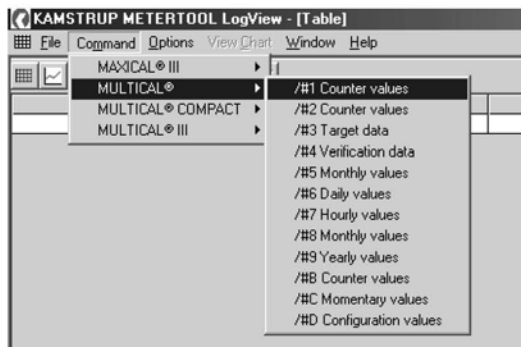

9.3 Option

- New Table New table
- New Chart New chart
- Set ComPort Indicates the selection of Com 1...8

9.4 View Chart

View Chart Shows energy data as a chart, at the same time the menus are changed and a field "Data" appears. Here can be selected between the columns found in the reading, select the one in question and it will be presented as a chart.

Example.:

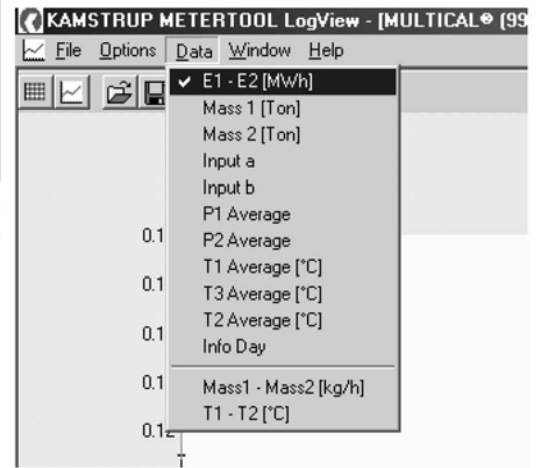

Charts can be stored under "File" or printed.

9.5 Window

This function makes it possible to change screen reading and to shift between the open tables and charts.

9.6 Help

Help Index Offers instructions and descriptions of the various functions of the program. Is activated directly from the program functions by using the F1 key.

About Contains program numbers and revisions.

10. Alphabetical register

The following alphabetical register explains the terms which appear on the monitor.

The register can both read as an integral part of the Technical Description, or used as a reference when a question arises.

A

A-B-CCC-CCC

The calculator's programming number. Determines the flow meter's placement in flow or return, measuring unit and number of pulses/liter.

Address

(RS-232) The calculator contains an addressable data sequence which can be used when several meters are connected in one mains, e.g. via external RS 232/485 converters.

Average

Indicates the averaging period, of which the peak flow or power is measured.

B

C

CCC

Flow meter code. E.g. CCC=119 is used with 100 imp/l for ULTRAFLOW® II, qp 1.5 m³/h.

Com 1...4

The computer's serial data port no. 1, 2, 3 or 4.

Config. No.

The meter's configuration number = DD-E-FF-GG-M-N indicates display reading, tariff type, pulse coding for the extra water meters as well as leak detection set up.

Customer No.

11-digit customer number which can be read on the display. The customer number can be changed without changing the serial number.

D

Date

The computer's calendar which is transferred to the calculator. The format is YY-MM-DD.

DD

Display code which indicates the display reading selected.

DD-E-FF-GG-M-N

The meters configuration number = DD-E-FF-GG-M-N indicates display reading, tariff type, pulse coding of extra water meters required as well as leak detection set up.

E

E

The required tariff is selected by means of "E". E.g. E=3 means "cooling tariff", whereas E=0 means "no tariff".

EN1434

European standard for heat meters.

Energy

The total energy (e.g. in kWh) is stored in the memory when the info code is changed.

F

FF

Flow meter coding of water meter VA. E.g. FF=04 means that water meter VA is coded for 10 l/imp.

Flow

The actual flow of water meter V1 can be used as tariff basis (E=2).

G

GG

Flow meter coding for water meter VB or connected electricity meter. E.g. GG=04 means that water meter VB is coded for 10 l/imp.

H

I

Info code

The latest 10 changes to the information code can be read.

Info date

The date when the information code appeared.

L

Landscape

Means that sheets with front labels will be printed horizontally.

M

Min

The number of minutes selected as average time for peak flow or peak power. Between 1 ... 1440 minutes can be chosen.

mm

The number of millimeters with which the front label's print must be adjusted.

MPE

(Maximum Permissible Error) Max. permitted error.

Q

<u>P</u>			<u>I</u>	
Power	The actual heat power of water meter V1 can be used as tariff basis (E=1).		Target date	The yearly target date which most often is the district heating company's billing date. On the target date all relevant registers are stored for later reading. The format is MM-DD, where MM=1...12 and DD = 1...28.
Print	Starts print of the table displayed.			
Programming	Starts programming the meter. All the data displayed will be transmitted to the meter.		Tariff limits	The tariff limits decide when the tariff registers TA2 and TA3 must accumulate energy parallel with the energy reading. The tariff limits are only used with E=1, 2, 3, 5, 9 or A.
P Status	The programming counter which indicates how many times the meter has been programmed since leaving factory.		Test initial	Registers the value before verification.
<u>Q</u>			Time	The computers actual time which is transmitted to the meter at programming.
Quick	(Qsum) High resolution measuring unit for heat energy.		TL2	Tariff limit 2 indicates the start conditions for TA2.
<u>R</u>			TL3	Tariff limit 3 indicates the start conditions for TA3.
Read meter	Reads the meters setting. All the meter's data are transmitted to the display.		Type No.	The meter's type number contains information on power supply, data module, sensor type, pick-up unit and language on the front label.
RS-232	(Address) calculator contains an adressable data string which can be used if a number of meters are connected in one mains, e.g. via external RS 232/485 converters.		<u>V</u>	
<u>S</u>			VA	Secondary water meter VA which is connected to clamp 65 and 66. The pulse value is set up via FF.
Save Customer	Stores a setting in the data base.		VB	Secondary water meter VB which is connected to clamp 67 and 68. The pulse value is set up via GG.
Serial No.	The meter's serial number.		V1	Flow meter V1 which is connected to clamp 9-10-11.
Start test	This command is used to start the automatic verification sequence.		V2	Flow meter V2 which is connected to clamp 9-69-11.
			View Chart	See data as a chart.

11. Dimensional drawings

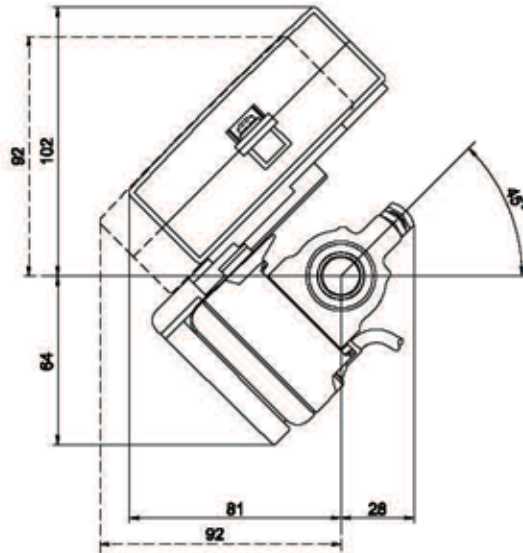

*MULTICAL® Type 66-CDE
mounted on ULTRAFLOW® II*

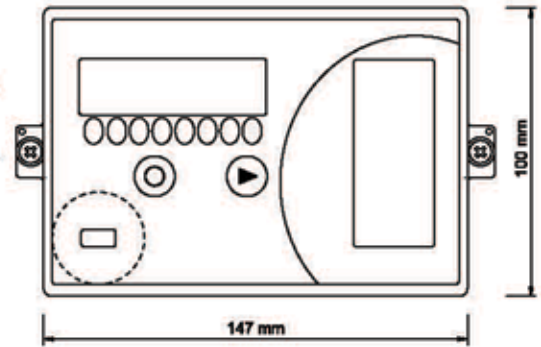

MULTICAL® Type 66-CDE's front measurements

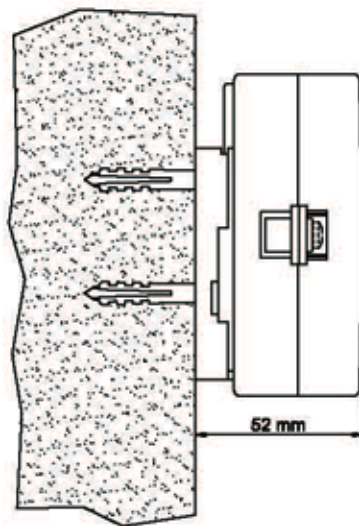

*Wall-mounted MULTICAL® Type 66-CDE
viewed from the side*



*Panel mounted MULTICAL® Type 66-CDE,
viewed from the side.*

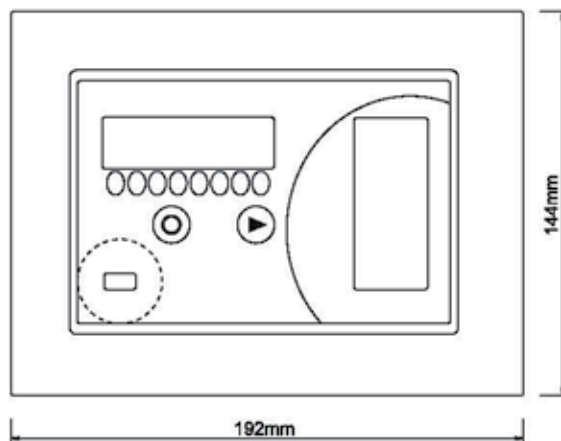

*Panel mounted MULTICAL® Type 66-CDE,
viewed from the front*

12. Temperature sensors

10.1 EN 60751 table for Pt500 sensors

Pt500 temperature sensors are used for MULTICAL® Type 66-CDE, according to EN 60751 (IEC 751). A Pt500 temperature sensor is a resistance sensor with a nominal resistance of 500 Ω at 0.00°C and 692.528 Ω at 100.00°C. All values for the resistance are stated in the

international standard IEC 751, which apply to Pt100 temperature sensors. The values for the resistances in Pt500 sensors are five times higher and can be seen in the table below [Ω]:

°C	0	1	2	3	4	5	6	7	8	9
0	500.000	501.954	503.907	505.860	507.812	509.764	511.715	513.665	515.615	517.564
10	519.513	521.461	523.408	525.355	527.302	529.247	531.192	533.137	535.081	537.025
20	538.968	540.910	542.852	544.793	546.733	548.673	550.613	552.552	554.490	556.428
30	558.365	560.301	562.237	564.173	566.107	568.042	569.975	571.908	573.841	575.773
40	577.704	579.635	581.565	583.495	585.424	587.352	589.280	591.207	593.134	595.060
50	596.986	598.911	600.835	602.759	604.682	606.605	608.527	610.448	612.369	614.290
60	616.210	618.129	620.047	621.965	623.883	625.800	627.716	629.632	631.547	633.462
70	635.376	637.289	639.202	641.114	643.026	644.937	646.848	648.758	650.667	652.576
80	654.484	656.392	658.299	660.205	662.111	664.017	665.921	667.826	669.729	671.632
90	673.535	675.437	677.338	679.239	681.139	683.038	684.937	686.836	688.734	690.631
100	692.528	694.424	696.319	698.214	700.108	702.002	703.896	705.788	707.680	709.572
110	711.463	713.353	715.243	717.132	719.021	720.909	722.796	724.683	726.569	728.455
120	730.340	732.225	734.109	735.992	737.875	739.757	741.639	743.520	745.400	747.280
130	749.160	751.038	752.917	754.794	756.671	758.548	760.424	762.299	764.174	766.048
140	767.922	769.795	771.667	773.539	775.410	777.281	779.151	781.020	782.889	784.758
150	786.626	788.493	790.360	792.226	794.091	795.956	797.820	799.684	801.547	803.410
160	805.272	807.133	808.994	810.855	812.714	814.574	816.432	818.290	820.148	822.004

IEC 751 Amendment 2-1995-07

The advantages of using resistance sensors with a high ohmic value (Pt500) compared to resistance sensors with a low ohmic value (Pt100) are several, including among others:

- Less influence from wire resistance in sensor cables and contact resistance in connections.
- Major ohmic change per °C gives better accuracy in the computer unit's analogue/digital converter.
- Better possibility of accurately pairing temperature sensor set.

12.2 SENSOR TYPES

MULTICAL® Type 66-CDE can be supplied with three different temperature sensor sets, all with either 1.5 meter or 3.0 meter cable. Further pocket sensors with 5, 10 or 20 meter cable can be supplied.

For application in open heating systems together with 66-D, 3 pocket sensors paired in sets can be supplied.

The three different sensor pairs function almost identically but are mounted differently. Below the most important characteristics for each type are indicated:

Type number		
Pt 500 Temperature sensors		
65	2 x Pocket sensor with 1.5 m cable	A
	2 x Pocket sensor with 3.0 m cable	B
	2 x Pocket sensor with 5 m cable	C
	2 x Pocket sensor with 10 m cable	D
66	2 x Short direct sensor with 1.5 m cable	F
	2 x Short direct sensor with 3.0 m cable	G
65	3 x Pocket sensor with 1.5 m cable	L
	3 x Pocket sensor with 3 m cable	M
	3 x Pocket sensor with 5 m cable	N
	3 x Pocket sensor with 10 m cable	P

12.3 Pt500 TEMPERATURE SET FOR POCKETS

Pt500 cable sensor, based on a 3.5 mm dia. 2-wire silicone cable. A 5.8 mm stainless tube protects the sensor element.

The stainless tube is fitted in a sensor pocket which has an internal dimension of 6 mm. The sensor pocket is supplied with a 1/2" BSP connection in stainless steel in 65, 90 and 140 mm lengths.

The sensor design with separate pocket means that the sensor can be replaced without shutting the water off. Additionally, the large selection of pocket lengths means that the sensors can be fitted in all pipe sizes.

The sensor pockets can be used up to a plant pressure of PN25.

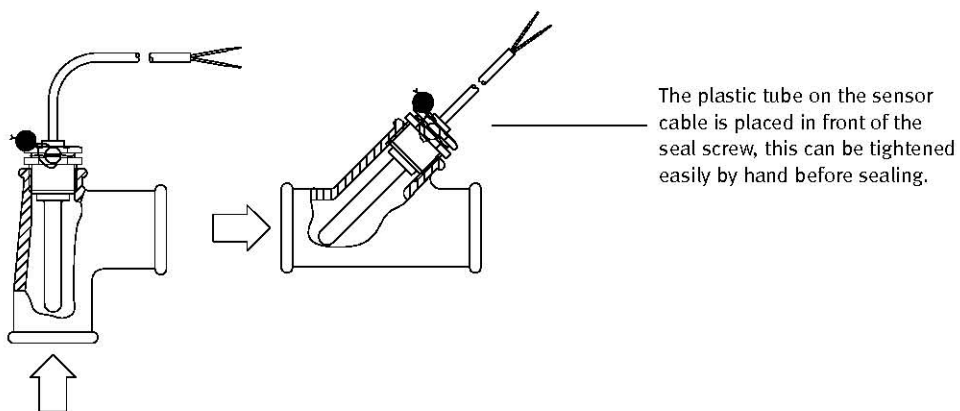

12.3.1 Pt500 DIRECT SHORT TEMPERATURE SENSORS

Pt500 direct short temperature sensors are designed in accordance with European standards for thermal energy meters EN 1434. The sensor is designed for fitting directly into the measuring medium, this means without a sensor pocket.

As above, this sensor also comprises a 3.5 mm diameter, 2-wire silicone cable. The sensor tube is made of stainless steel and has a diameter of 4 mm at its end. The sensor can be fitted in a special T-section, which can be supplied for 1/2", 3/4" and 1" pipe installations. Furthermore, the direct mounted short temperature sensor can also be fitted in a standard 90° T using a 1/2" or 3/4" BSP to M10 nipple. The sensor can also be fitted directly into many types of flow meters – which obviously reduces installation costs.

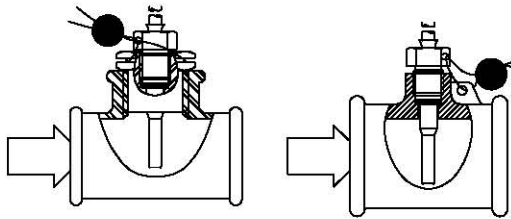

12.4 SENSOR CABLE

As mentioned previously, the temperature sensor comprises silicone cable. This is both heat resistant and flexible.

The cross-sectional area is 0.5 mm² for pocket mounted sensor sets which corresponds to 0.04K/metre. The two other sensor types have a cross sectional area of 0.25 mm², which corresponds to a positive measure deviation of 0.08K/metre. The figures stated apply for 2 individual cross sectional areas in a 1 meter length.

With all temperature probe types the cable length for the forward and return probes must be identical. If the lengths are not the same, the cable resistance will affect the measurement of the differential temperature.

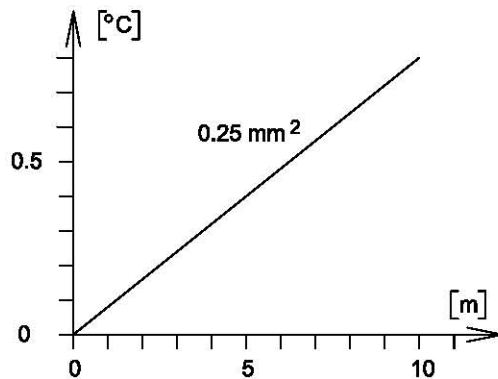

We would generally advise customers to use the temperature sensors with the cable supplied. If the cable is too long, the excess can be rolled up and secured with cable strips.

If after careful consideration, you decide to shorten the cable, please note that both cables must have exactly the same length. Extension of the sensor cables must not take place as the cable joints can contribute to decreased long-term stability.

In applications where the temperature sensors have long cables, consideration must be shown during installation. The sensor cables must be installed with at least 25 cm distance to other cables out of regard to EMC. Besides the flow and return cables must be installed in such a way that the temperature differences between the two cables are minimized. The graph below shows how large a measuring error temperature differences between the cables can result in:

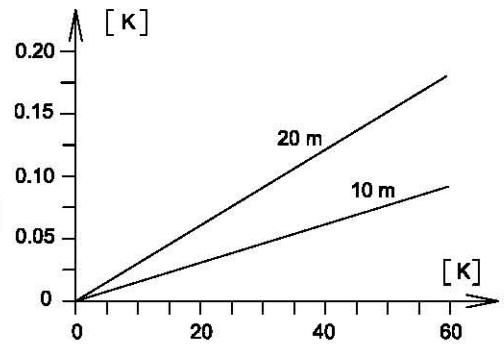

If the temperature difference between the two cables amounts to e.g. 60K, this would, with 20 m sensor cables, cause a measuring error of 0.18K at measuring of Δt , which in all applications must be seen as unacceptable. Generally it is recommended to keep the temperature difference between the two cables below 10K.

13. Trouble shooting

Before the meter is sent for repair or control, we would recommend that you check the table below to find a possible cause for the error:

Symptom	Possible cause	Suggestion for correction
No updating of display values. Control segments in the display do not move.	Voltage supply is missing	Change battery or control mains supply Apply info-hour counter to evaluate duration of supply shortage
No function on the display (blank display)	Power supply and Back-up supply is missing	Change Back-up cell Change battery or check mains supply
Energy and m ³ not accumulated	Read "info" on the display. If "info" = 000 ⇒ If "info" > 000 ⇒	Check both flow meter and temperature sensor Check the fault indicated by the info code Read Info logger for further details
Accumulation of m ³ , but not of energy (e.g. MWh)	The flow and return sensors are swoped either in the installation or in the connection	Install the sensors correctly
No accumulation of m ³	No volume pulses	Check the flow meter connection Check flow meter direction Change the flow meter
Incorrect accumulation of m ³	Error in flow meter Flow meter is placed wrong Wrong programming	Submit the meter for repair Place the flow meter correctly Send MULTICAL® for check
Wrong temperature displayed	Defective temperature sensor Insufficient installation	Change the sensor set Overhaul the installation
Temperature displayed is too low or accumulated energy (e.g. MWh) is too low	Poor thermal sensor contact Heat dissipation Pocket sensors too short	Place the sensors right at the bottom of the temperature pockets Isolate the sensor pockets Replace with longer sensors
No registration of cooling energy	"Min. T1" is programmed to 0°C	Program "Min. T1" to e.g. 25°C via METERTOOL
Faulty temperature indication and no data after replacement of 66-B to 66-CDE	The connection print 5550-492 must always be used for 66-CDE	Replace the connection print
The PQ-Controller is not functioning	Faulty programming	Program: E=A FF=00 GG=00 Set "PQ-Controller Data"

14. Approvals

14.1 TYPE APPROVAL

MULTICAL® Type 66-CDE has been approved by DELTA in accordance with EN1434-4 and OIML R75. The type approval encompasses all plug-in modules and supply modules.

The test report – No. K286095 – has been used as a basis for type approval in a number of countries, incl. Denmark.

TS	27.01	TS	27.01	PTB	22.55	22.52
	062		098		00.03	01.03
	DS 2340		EN 1434			

Please contact Kamstrup A/S for further information relating to type approvals and verification facilities.

14.2 CE-DECLARATION

MULTICAL® Type 66-CDE is CE-marked in accordance with EMC-directive 89/336/EEC, paragraph 10.2. The declaration of compliance has been drawn up by DELTA, with certificate No. 307.

14.3 Leakage detection

Test report from Danish Technological Institute can be commissioned from Kamstrup A/S.

DELTA Electronics Testing



ATTESTATION OF CONFORMITY

EMC assessment - Certificate no. 307

Since 1992 DELTA Electronics Testing has been appointed Competent Body by the notified authority National Telecom Agency, Denmark. The attestation of conformity is in accordance with Article 10.2 of the Council EMC Directive 89/336/EEC

DELTA client
 Kamstrup A/S
 Industrivej 28, Stilling
 DK-8660 Skanderborg
 Telephone: +45 89 93 10 00
 Telefax: +45 89 93 10 01

Product identification (type(s), serial no(s).)
 A calculator used as a subassembly for a heat or cooling meter
 Type MULTICAL 66 C "X" "Y"
 "X": From 1 up to 5 or D or F
 "Y": From 2 up to 6

Manufacturer
 Kamstrup A/S

Technical report(s)
 Assessment sheet no. 307

Standards/Normative documents
 EMC Directive 89/336/EEC Article 10.2

The product identified above has been assessed and complies with the specified standards/normative documents. The attestation does not include any market surveillance. It is the responsibility of the manufacturer that mass-produced apparatus have the same EMC quality. The attestation does not contain any statements pertaining to the EMC protection requirements pursuant to other laws and/or directives other than the above mentioned if any.

Hørsholm, 2000-02-04

 Jørgen Duvald Christensen
 Department Manager, EMC

 Per Thåstrup Jensen
 Project Manager, EMC

DELTA
 Electronics Testing
 Venlighedsvej 4
 DK-2970 Hørsholm
 Denmark
 Tel. (+45) 45 86 77 22
 Fax (+45) 45 86 58 98
 www.delta.dk
 BGBK
 VAT DK 12275110
 DELTA
 Electronics Testing
 is a division of DELTA
 Danish Electronics,
 Light & Acoustics - an
 independent centre
 for advanced technology
 Divisions:
 Electronics Testing
 Microelectronics
 Software Engineering
 Light & Optics
 Acoustics & Vibration

DELTA Danish Electronics, Light & Acoustics is an independent organization, affiliated to the Danish Academy of Technical Sciences (ATV).

15. Disposing of energy meters

Kamstrup's energy meters have been designed and constructed for many years' reliable operation at heat consumers. But, as you know, all good things must come to an end, and a worn out energy meter must be disposed of with consideration to the environment. In constructing MULTICAL® and ULTRAFLOW® we have aimed at recycling as many components as possible.

■ DISPOSAL BY THE SUPPLIER

Kamstrup are willing to dispose of worn out energy meters MULTICAL® and ULTRAFLOW® in an environmentally safe manner – please contact us before sending the meters.

The disposal arrangement is free of charge to the customer, who only pays for transportation to Kamstrup A/S.

■ CUSTOMER SENDS TO DISPOSAL

The meters must not be separated previous to destruction. The entire meter is sent to nationally/locally approved electronics scrap centres. A copy of this page should be enclosed in the shipment and the customer made aware of the contents.

■ CUSTOMER DISPOSAL

The meters must be separated as listed, parts must be sent to separate, approved destruction.

The lithium batteries must not be postponed to mechanical thrust and the lead-in wires must not be shorted during transportation.

Please send any questions you may have concerning environmental matters, to:

Kamstrup A/S

Att.: Quality Control Dept.

Fax.: +45 89 93 10 01

E-mail: energi@kamstrup.dk

Part	Information on materials	Recommended disposal
Lithium battery in MULTICAL® (½ AA-cell and D-cell)	Lithium and Thionyl-chloride >UN 3091< - ½ AA-cell: 0.3 g lithium - D-cell: 4.9 g lithium	Approved destruction of lithium cells
PC boards in MULTICAL® and ULTRAFLOW® (LC-display and electrolytic capacitor are removed)	Copper epoxide laminate with soldered components	PC board scrap for concentration of noble metals
LC-display	Glass and liquid crystals	Approved scrap centre for LC-displays
Electrolytic capacitor	Can contain PCB	Approved destruction of electrolytic capacitors
Cables for flow meters and sensors	Copper with PVC- or silicone mantle	Cable recycling
Plastic parts, cast	Noryle and ABS	Plastic recycling
ULTRAFLOW® meter case	Brass/red brass and stainless steel	Metal recycling
Packing	Recycled cardboard	Cardboard recycling

16. Documents

List of data sheets, installation and operation instructions for this product.

	Danish	English	German	Russian
Technical Description	5511-633	5511-634	5511-635	5511-636
Data sheet	5810-279	5810-280	5810-281	5810-282
Installation instructions	5511-540	5511-542	5511-544	5511-554
Operation instructions	5511-541	5511-543	5511-545	

