

Operation conditions

Operation conditions/measuring ranges:

Calculator	θ : 2°C...180°C	$\Delta\theta$: 3K...170K
Temperature sensor pair	θ : 2°C...50°C	$\Delta\theta$: 3K...30K
Flow sensor	θ : 2°C...50°C	

Mechanical environment:

M1 (fixed installation with minimum vibration).

Electromagnetic environment:

E1 (Domestic and light industrial). Signal cables from the meter must be separated by at least 25 cm distance to other installations.

Climatic environment:

The installation of MULTICAL® shall be made in non-condensing environments and in closed location (indoor). The ambient temperature must be within 5...55°C.

Maintenance and repair:

The energy supplier is allowed to change communication module, battery and temperature sensor pair. The flow part must not be separated from the base unit that contains the flow sensor electronics. All repairs require a following calibration on an accredited laboratory.

MULTICAL® 601, type 67-C is suitable for temperature sensors type Pt500.

Battery for replacement: Kamstrup type 66-00-200-100.

MULTICAL® 601 & ULTRAFLOW® 14

English

INSTALLATION



Kamstrup

Kamstrup A/S
Industrivej 28, Stilling, DK-8660 Skanderborg
TEL: +45 89 93 10 00 · FAX: +45 89 93 10 01
info@kamstrup.com · www.kamstrup.com

1. General information

⚠ Read this guide before installing the energy meter. If the meter is installed incorrectly, Kamstrup's guarantee obligations will no longer apply.

Please note that the following installation conditions must be obeyed:

- Pressure stage ULTRAFLOW®: PN16/PN25, see marking. Marking of flow part does not cover included accessories
- Pressure stage Kamstrup sensor set type DS: PN16
- Pressure stage Kamstrup stainless steel pockets: PN25

2. Mounting of temperature sensors

Temperature sensors used to measure flow and return temperatures make up a matched pair of sensors and must never be separated.

Usually, MULTICAL® 601 is supplied with mounted temperature sensors. The cable length must not be changed. Replacement of sensors, if required, must always be made in pairs.

One sensor is marked with a red sign, and must be installed in the flow pipe (cold pipe). The other sensor is marked with a blue sign, and must be installed in the return pipe (warm pipe).

2.1 Pocket sensor pair

Preferably, sensor pockets must be mounted in tee-pieces or in 45° lateral Y-pieces. The tip of the sensor pocket must be placed pointing towards the flow direction and in the middle of the water flow.

Temperature sensors must be mounted from below.

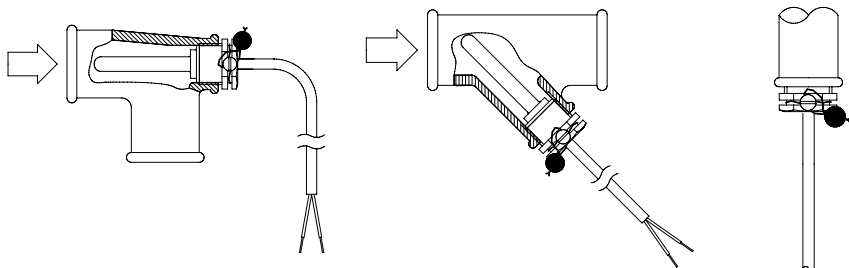

Temperature sensors should be inserted to the bottom of the pockets. If a quick response time is required, “non-hardening” heat conducting paste can be used.

Push the plastic sleeve on the sensor cable into the sensor pocket and secure the cable with the supplied M4 sealing screw. Fasten the screw with your fingers only. Seal the pockets using seal and sealing wire.

2.2 Short direct temperature sensor set

The short direct sensor can be mounted in special ball valves or in special angle tee-pipes, both with threads up to R1 and built-in M10 union for the short direct sensor.

For mounting in existing cooling installations with standard angle tees Kamstrup A/S can also supply R $\frac{1}{2}$ and R $\frac{3}{4}$ brass nipples which fit the short direct sensors.

The short direct sensor can also be fitted directly into all ULTRAFLOW® variants from Kamstrup A/S with G $\frac{3}{4}$ and G1 thread on the meter case. Fasten the brass unions of the sensors lightly (approx. 4 Nm) by means of a 12 mm face wrench, and seal the sensors with seal and wire.

Temperature sensors must be mounted from below.

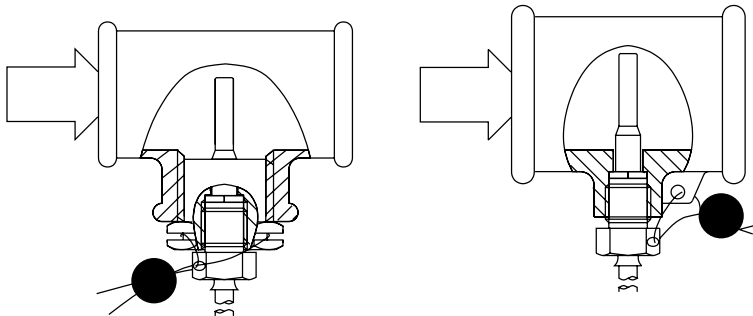

3. Information codes “INFO”

MULTICAL® 601 constantly monitors a series of important functions. If a serious error occurs in the measuring system or in the installation, an “INFO” appears in the display and an info code can be read by activating the upper front plate button until the measuring unit shows an “INFO” in the display. The info code is only visible while the error exists.

Info code	Description	Response time
0	No irregularities	-
1	Supply voltage has been cut off	-
8	Temperature sensor T1 outside measuring range	1...10 min.
4	Temperature sensor T2 outside measuring range	1...10 min.
	ULTRAFLOW® 14 info (if activated CCC=4XX)	
16	Flow sensor V1, Datacomm error, signal too low or wrong flow direction	After reset and 1 day (00:00)
2048	Flow sensor V1, Wrong meter factor	After reset and 1 day (00:00)
4096	Flow sensor V1, Signal too low (Air)	After reset and 1 day (00:00)
16384	Flow sensor V1, Wrong flow direction	After reset and 1 day (00:00)

If several info codes appear at the same time the sum of the info codes is shown. E.g. if both temperature sensors are outside measuring range, info code 12 will appear.

4. Mounting of flow sensor

Before mounting the flow sensor, flush the system thoroughly and remove protection plugs/plastic membranes from the flow sensor. Correct flow sensor position (flow or return pipe) appears from the front label placed on the MULTICAL® 601. The flow direction is indicated by an arrow on the side of the flow sensor.

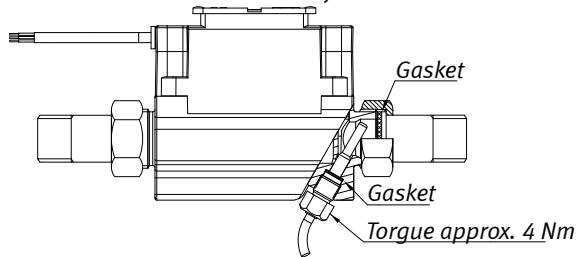

Glands and gaskets must be mounted as shown on the above drawing.

Straight inlet: ULTRAFLOW® requires neither straight inlet nor outlet to meet the Measuring Instruments Directive (MID) 2004/22/EC, OIML R75:2002 and EN 1434:2007. Only in case of heavy flow disturbances before the meter will a straight inlet section be necessary. We recommend to follow the guidelines in CEN CR 13582.

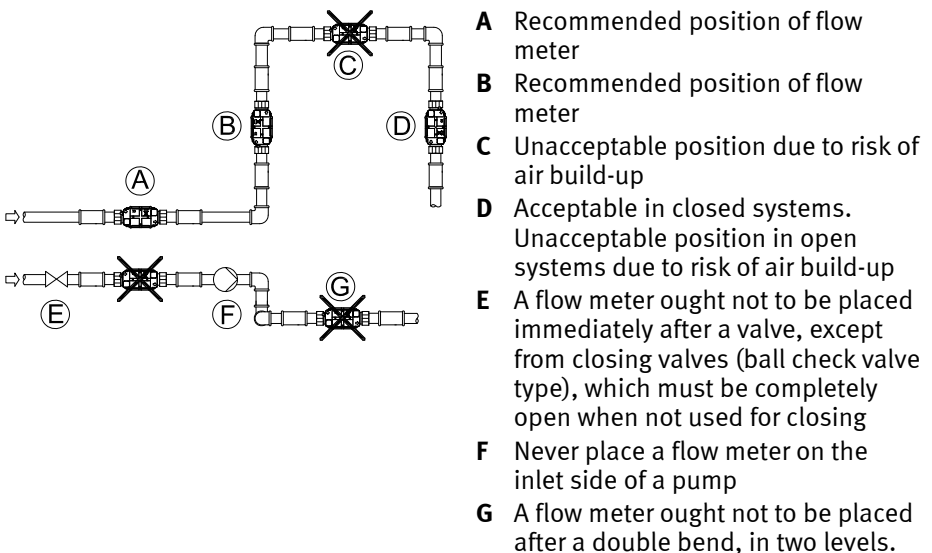

To prevent cavitation, the operating pressure at the ULTRAFLOW® must be min. 1.5 bar at qp and min. 2.5 bar at qs.

ULTRAFLOW® must not be exposed to pressures below ambient pressure (vacuum).

4.1 Mounting of ULTRAFLOW®

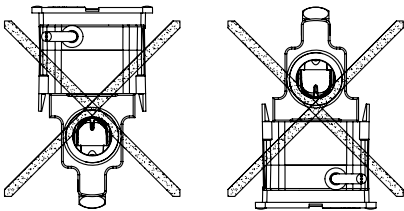
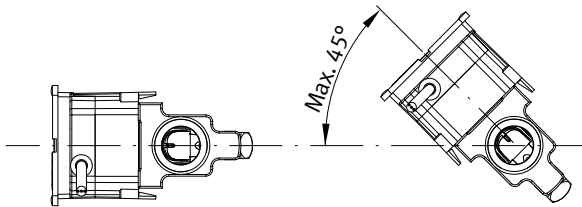
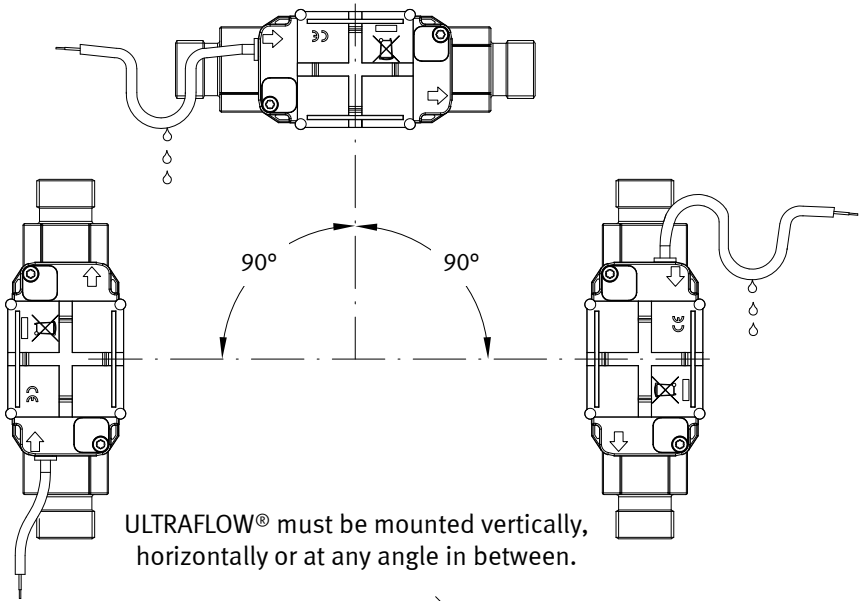

The ULTRAFLOW® housing must not be mounted facing upwards or downwards.

5. Mounting of the calculator/Pulse Transmitter (66-99-617)

5.1 In cooling applications

The MULTICAL® 601 calculator can be mounted in two different ways:

5.1.1 Separately/wall mounting

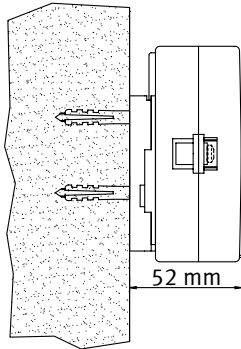

The wall bracket gives you the opportunity of mounting MULTICAL® 601/Pulse Transmitter directly on an even wall. Use the bracket as a template to mark and drill two holes with a diameter of 6 mm in the wall.

Installation of calculator/Pulse Transmitter

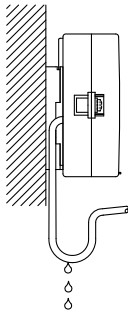

Front, vertical

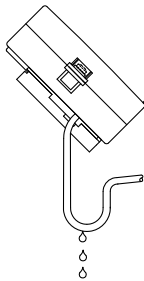

Front, at an angle
between horizontal
and vertical

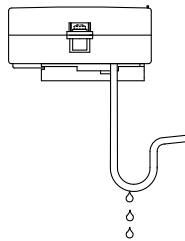

Front, horizontal

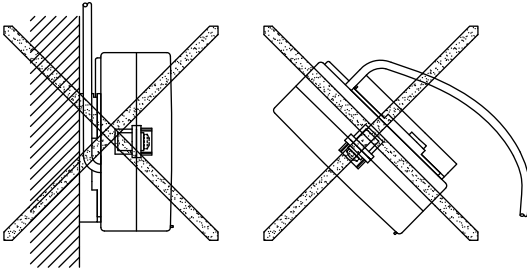

Note! Cables **must** be installed from below.

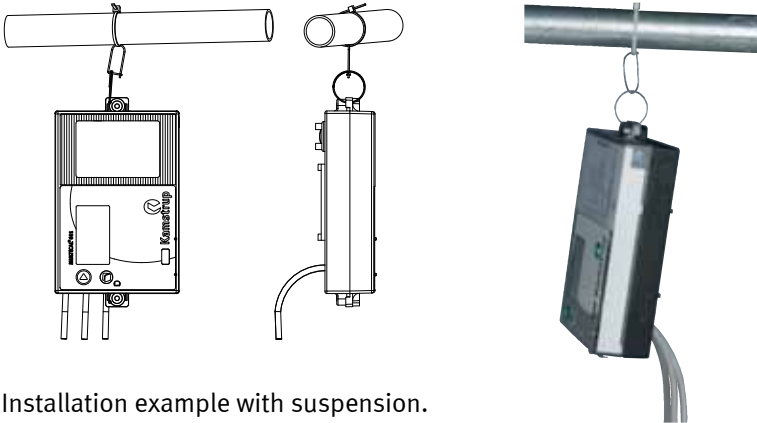

Installation example with suspension.

Note: The suspension **must** not be used on condensing pipes.
Suspension kit item no. 5915-144. Not included.

5.2 In applications with medium temperature less than 5°C under ambient temperature

In applications, with medium temperature less than 5°C under ambient temperature, calculator/Pulse Transmitter can also be mounted on the flow part. *See examples below.*

Threaded meter with MULTICAL®/Pulse Transmitter mounted on ULTRAFLOW®.

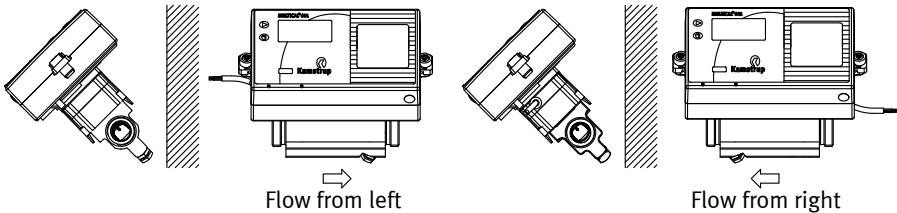

Flange meter with MULTICAL®/Pulse Transmitter mounted on ULTRAFLOW®

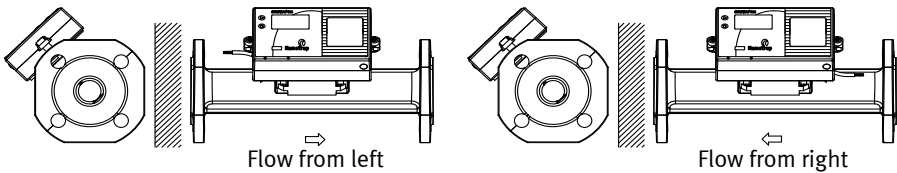

6. Installation as compact meter

MULTICAL® mounted together with flow sensor electronic.

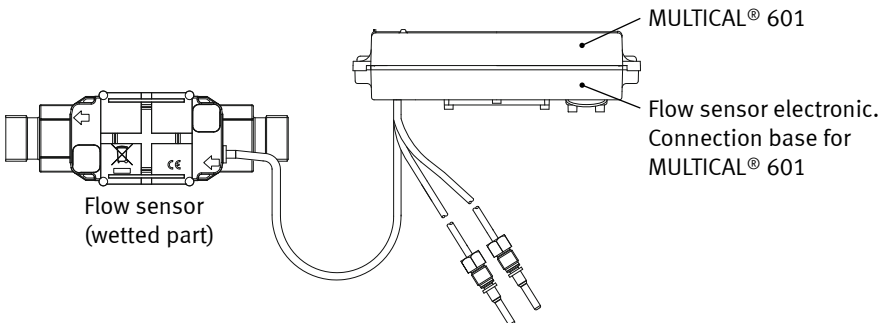

⚠ OBS! Flow sensor cable, cable between flow sensor (wetted part) and flow sensor electronic, must not be disconnected/changed, or cut.

6.1 Power supply

MULTICAL® 601 can be power supplied by means of a built-in lithium battery, an internal 24 VAC mains module or an internal 230 VAC mains module.

The two wires from the battery or mains module are mounted in terminals 60 and 61 of the calculator.

⚠ The polarity has to be correct; connect the red wire to terminal no. 60 (+) and the black wire to terminal no. 61 (-).

6.1.1 Battery supply

MULTICAL® 601 is connected to a lithium battery, D-cell. The battery is marked with installation year, e.g. 2009, as well as production date.

Optimal battery life is obtained by keeping the battery temperature below 30°C, e.g. by wall mounting.

The voltage of a lithium battery is almost constant throughout the whole lifetime of the battery (approx. 3.65 V). Therefore, it is not possible to determine the remaining capacity by measuring the voltage.

The battery cannot and must not be charged and must not be short-circuited. Used batteries must be handed in for approved destruction, e.g. at Kamstrup's.

6.1.2 Mains modules

The modules are protection class II and are connected via a two-wire cable (without ground) through the cable bush of the calculator placed in the right side of the connecting base. Use a connecting cable with an outer diameter of 5–10 mm and ensure correct dismantling as well as correct mounting of the cable relief.

Max. permitted fuse: 6 A

National installation regulations must be obeyed..

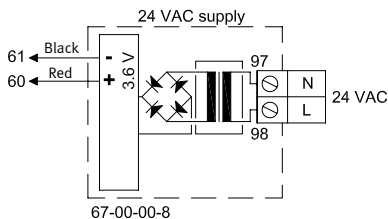

24 VAC

E.g. transformer 230/24 V, type 66-99-403 can be used.

NB! MULTICAL® 601 cannot be supplied from 24 VDC.

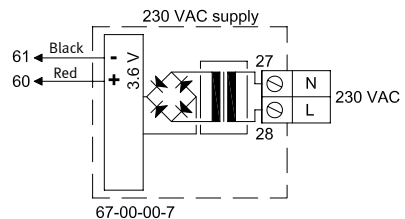

230 VAC

This module is used for direct mains connection.

6.2 Operational check

Carry out an operational check when the energy meter has been fully mounted. Open the thermo-regulators and cocks in order to establish a water flow through the heating system. Activate the upper push button on the MULTICAL® 601 and check that the display values for temperature and water flow are reliable.

6.3 Electrical connection

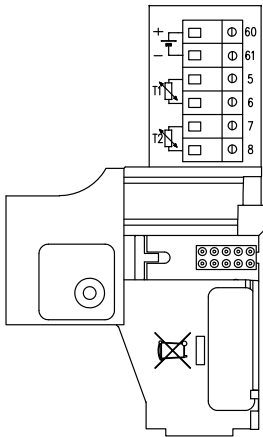

The polarity of the temperature sensors T1 and T2 is unimportant.

	Terminal No.	Standard measurement of heat and cooling
T1	5–6	Sensor in flow pipe (red)
T2	7–8	Sensor in return pipe (blue)

6.4 Plug-in modules

MULTICAL® 601 can be extended with a number of extra functions in the form of plug-in modules. On page 12 is a short description of the individual modules.

6.4.1 Data + pulse inputs, type 67-00-10

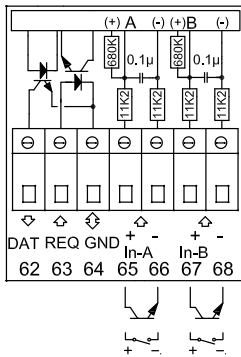

Data terminals are e.g. used for connecting a PC. The signal is passive and galvanically separated through optocouplers. Conversion into RS232 level requires connection of data cable 66-99-106 (D-Sub 9F) or 66-99-098 (USB) with the following connections:

62	Brown	(DAT)
63	White	(REQ)
64	Green	(GND)

NB! If data reading must be compatible with MULTICAL® 66-CDE, top module 67-06 must be used in MULTICAL® 601.

The pulse inputs can be used for connecting electricity and water meters. Please note the maximum pulse frequency and correct pulse coding (I/pulse and Wh/pulse) which are selected by means of the FF and GG configuration.

65 - 66	Input A
67 - 68	Input B

6.4.2 M-Bus, type 67-00-20

M-Bus can be mounted in star, ring or bus topology. Depending on the power supply of the M-Bus Master as well as the total cable resistance, up to 250 meters can be connected.

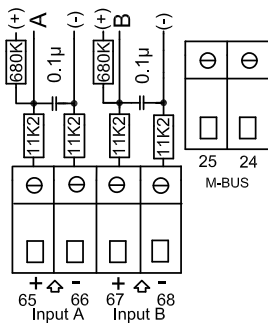

Cable resistance < 29 Ohm

Cable capacity < 180 nF

The M-Bus network is to be connected to terminals 24 and 25. The polarity is unimportant. M-Bus is supplied with pulse inputs.

6.4.3 Radio Router + pulse inputs (67-00-21)

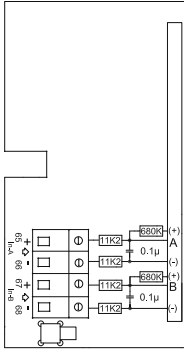

The radio module is supplied as standard to operate in a licence-free frequency band but can also be supplied to other frequencies requiring licence.

The radio module is prepared to form part of a Kamstrup radio network, where the data are automatically transferred to system software via the network components RF Router and RF Concentrator.

The radio module has 2 extra inputs.

The RadioRouter module must be used with mains supply.

6.4.4 Prog. data logger + RTC + 4...20 mA inputs + pulse inputs (67-00-22)

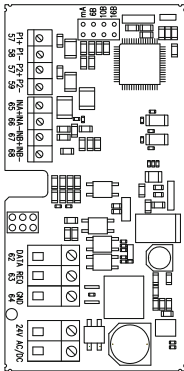

The module has connection possibility for two pressure transmitters on terminals 57, 58 and 59 and can be adjusted for current reading or pressure ranges of 6, 10 or 16 bar.

The module is prepared for remote reading, data from meter/module being transferred to the system software via the connected external GSM/GPRS modem on terminals 62, 63 and 64.

Furthermore, the module has two extra pulse inputs. The module must always be powered by 24 VAC.

6.4.5 Analog outputs

Type 67-00-23, see *Installations manual 5512-369 (DK-GB-DE)*.

6.4.6 Lon Works

Type 67-00-24, see *Installations manual 5512-396 (DK) or 5512-403 (GB)*.

6.4.7 Radio + pulse inputs, type 67-00-25/26

The radio module is used for wireless communication via a license-free radio frequency and is available for internal or external antenna.

For further information on radio please refer to *Technical Description for Radio (5512-013)*.

The pulse inputs in this module are identical with the ones described earlier.

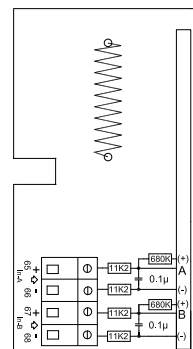

6.4.8 Top modules

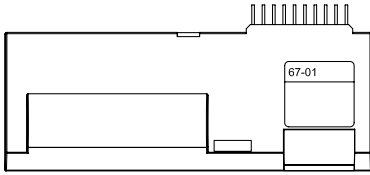

Type 67-01: RTC (Real Time Clock)

The top module consists of real time clock and battery backup.

When the MULTICAL® 601 calculator top is placed in the connecting bracket and is powered, current date and time is transferred from the top module to the calculator.

The top module is recommended for applications in which correct date/time in data loggers as well as in time-controlled tariff is considered important.

Real time clock and battery backup are standard features in all other top modules.

Terminal screws are not used in this module.

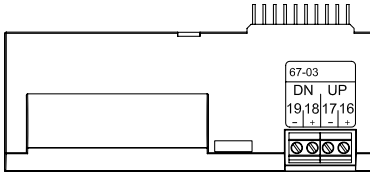

Type 67-03: RTC + PQ-limiter + hourly data logger

The module has two pulse outputs which can be used for UP/DOWN control of a low-speed three-point motor-operated valve via an external solid-state relay, type S75-90-006 and a 230/24 V trafo, type 66-99-403.

The required power and flow limits are entered into MULTICAL® 601 via the PC-program METERTOOL.

Also see instructions: 5512-498

The module also includes an hourly data logger.

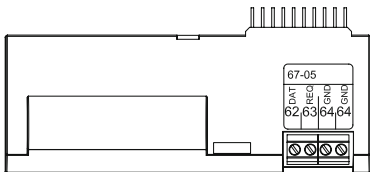

Type 67-05: RTC + data output + hourly data logger

The module has a galvanically separated data port which functions together with the KMP-protocol. The data output can be used for e.g. connection of external communication units or other hardwired data communication which it is not expedient to carry out via the optical communication on the meter's front.

62: DATA (Brown) – 63: REQ (White) – 64: GND (Green). Use data cable type 66-99-106 with 9-pole D-sub or type 66-99-098 with USB connector.

The module also includes an hourly data logger.

Only current and accumulated data can be read. Data loggers for time/days/months/years cannot be read through the data port of top module 67-05.

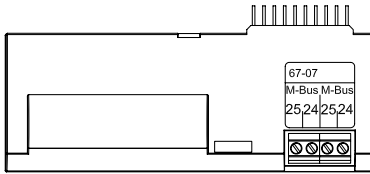

Type 67-07: RTC + M-Bus

M-Bus can be connected in star, ring and bus topology.

Depending on the M-Bus Master and the cable length/cross section, up to 250 meters can be connected with primary addressing, and even more if secondary addressing is used.

Cable resistance in network: < 29 Ohm

Cable capacity in network: < 180 nF

The connection polarity of terminals 24-25 is unimportant.

Normally the primary address consists of the last digits of the customer number (000-250), but it can be changed via the PC program METERTOOL.

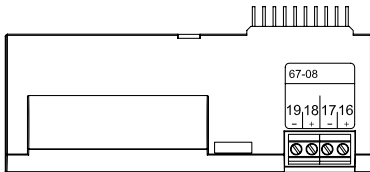

Type 67-08: RTC + hourly data logger + pulse outputs

This top module has two configurable pulse outputs, which are suitable for volume and energy pulses for heat meters, cooling meters and combined heat/cooling meters. The pulse resolution follows the display (determined in the CCC-code). E.g. CCC=119 (qp 1.5):

1 pulse/kWh and 1 pulse/0.01 m³.

The pulse outputs are optoinsulated and stand 30 VDC and 10 mA.

Normally energy (CE) is connected to 16-17 and volume (CV) to 18-19, but other combinations can be selected via the PC program METERTOOL which is also used for selecting pulse widths 32 or 100 ms. Furthermore, the module includes a hourly data logger.

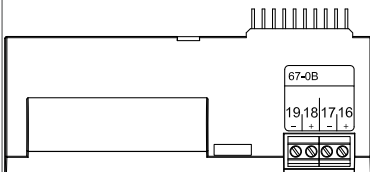

Type 67-0B: RTC + 2 pulse outputs for CE and CV + prog. data logger

The RTC and pulse output functions of this top module are identical with the functions described under top module 67-08.

The top module is prepared for use in a Kamstrup radio network together with the Radio Router base module 670021003xx, read data being transferred to the system software via network unit RF Concentrator.

7. Installation of flow sensor as separate meter

Pulse Transmitter mounted together with flow sensor electronic.

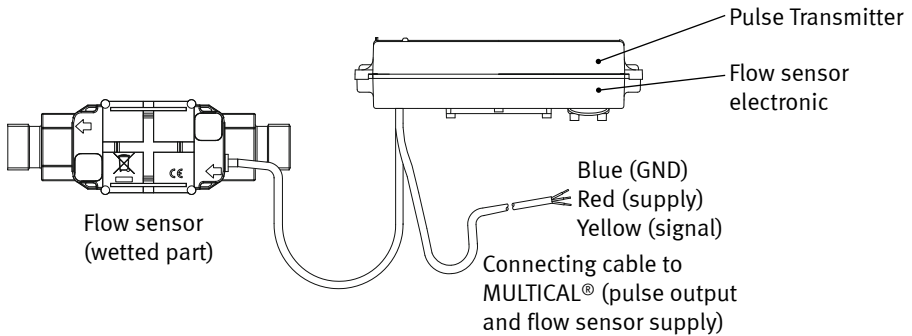

⚠ OBS! Flow sensor cable, cable between flow sensor (wetted part) and flow sensor electronic, must not be disconnected/changed, or cut.

7.1 Electric connection

Connection MULTICAL® (separate calculator) and ULTRAFLOW® 14 incl. Pulse Transmitter (66-99-617). ULTRAFLOW® 14 incl. Pulse Transmitter is supplied from MULTICAL®.

NB! Do not mount power supply inside Pulse Transmitter (66-99-617).

ULTRAFLOW® 14 incl. Pulse Transmitter, Cable.	→	MULTICAL® Bracket, (separate calculator)
Blue (GND)	→	11
Red (supply)	→	9
Yellow (signal)	→	10

Connection example

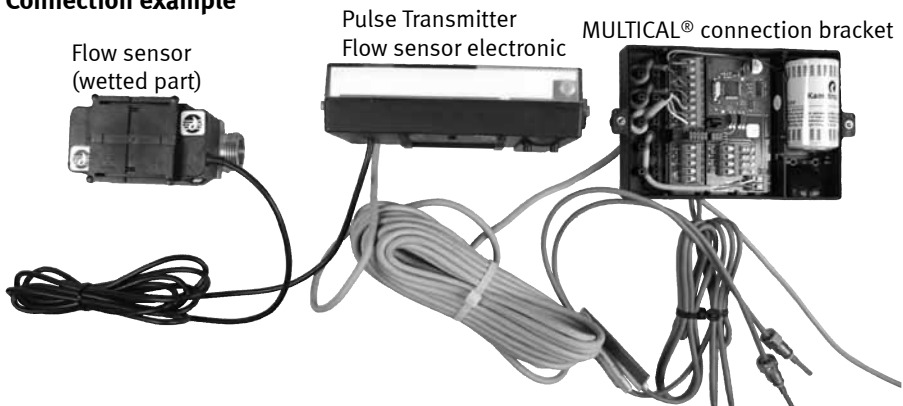

Consumed energy in kWh, MWh or GJ

E3
0004,793
MWh

DATE LOG
20060601

Latest yearly target date

LOG
0003,187
MWh

DATE LOG
20060601

Energy consumption count on latest yearly target date, followed by previous yearly target date. Followed by monthly target date data

VOL
0032456
m³

DATE LOG
20060601

Latest yearly target date

Number of operating hours

0008760
h

LOG VOL
002564
m³

District cooling water volume count on latest yearly target date, followed by previous yearly target date. Followed by monthly target date data

Current flow pipe temperature

t
1033
°C

t
8

Yearly average inlet temperature.

t
12

Monthly average inlet temperature.
MWh Monthly average temperature is reset every month, depending on target date.

Current return pipe temperature

t 2
15.74
°C

t 2
14

Yearly average outlet temperature.

Current temperature difference (heating)

t 1-2
- 5.41
K

t 2
17

Monthly average outlet temperature.
MWh Monthly average temperature is reset every month, depending on target date.

Current water flow
Press to see the peak value of the current year and historic yearly and monthly values.

VOL
3.16
l/h

Current cooling power
Press to see the peak value of the current year and historic yearly and monthly values.
Followed by the accumulated water consumption on inputs A and B and tariff registers TA2 and TA

220
kW

Current information code
(contact the utility if the figure differs from "0")

INFO
256

... and the INFO code of the latest 36 changes

INFO LOG
20060104

Data logger indicates the date ...

Indication of the number of current and corrected error conditions

INFO N°
0

