

Data sheet

MULTICAL® 602 & ULTRAFLOW® 14 cooling

- Complete range of communication modules
- High Power Radio Router module
- Data loggers
- Info loggers
- Data backup in case of power failure



Contents

Cooling meter with unlimited communication	2	Dimensional sketches calculator	17
Calculator functions	5	Dimensional sketches temperature sensors	17
Electrical data	10	Dimensional sketches flow sensors	18
Flow data	12	Installation of calculator	20
Pressure loss	12	Installation example with suspension	20
Mechanical data	13	Installation of temperature sensors	21
Materials	13	Mounting of flow sensors	21
Order specifications	14	Mounting of ULTRAFLOW® 14	22
Accessories	16		

Cooling meter with unlimited communication

Application

MULTICAL® 602 is an all-purpose energy calculator for cooling and heat/cooling together with almost any kind of pulsed flow sensors and with 2-wired temperature sensor pairs. Used together with Kamstrup ultrasonic flow sensor ULTRAFLOW® 14, even more advanced functions are available. On account of its pinpoint accuracy the meter registers precise consumption throughout the whole lifetime of the meter. The meter is maintenance-free and has a long lifetime which guarantees minimum yearly operating costs. MULTICAL® 602 and ULTRAFLOW® 14 are used for measurement of cooling and heat/cooling in all water based plants between q_p 1.5 m³/h and q_p 100 m³/h with flow temperatures from 2 °C to 50 °C for cooling installations and flow temperatures from 2 °C to 130 °C for heat/cooling installations. The meter is simple to install, read and test.

Functionality

MULTICAL® 602 is characterized by its complete range of communication modules and integral RTC (Real Time Clock), which make it easy to fit the meter into all applications independent of reading type. The meter can be fitted with LON, SIOX, M-Bus, a data module, Metasys N2 and Ethernet/IP for wired communication. If the meter is to be integrated into a wireless network, you can select radio, Wireless M-Bus, Zigbee or one of Kamstrup's new modules: GSM/GPRS or High Power Radio Router.

The calculator's info codes and data loggers make up an invaluable tool for troubleshooting, error correction and analysis of energy consumption. The info logger constantly monitors a number of key functions in the meter, such as error in the measuring system, power failure, leak, burst, or mounting of the flow sensor in the wrong flow direction. In such cases a flashing "INFO" and an info code appear in the display. MULTICAL® 602 saves consumption data on a yearly, monthly, daily and hourly basis, which provides the operations manager with a complete performance analysis.

Operations optimisation

In case of power failure data is backed up, thus securing billing of consumption data. If the meter is supplied with battery, the battery lifetime has been considerably increased – up to 13 years incl. Wireless M-Bus.

Finally, MULTICAL® 602 with ULTRAFLOW® 14 and the precisely matched temperature sensors guarantee accurate measuring results even at minimal temperature differences. The flow sensor's long-term stability and accuracy are not influenced by flow velocity, flow disturbances or wear, which ensures an optimal operation.

ULTRAFLOW® 14 is not suitable for use with other media than water and should therefore not be used with e.g. non-freezing additives like glycol.

Calculator functions

Energy calculation

MULTICAL® 602 calculates energy based on the formula in EN 1434-1, in which the international temperature scale from 1990 (ITS-90) and the pressure definition of 16 bar is used. The energy calculation can in a simplified way be expressed as:

$$\text{Energy} = V \times \Delta\Theta \times k.$$

V is the supplied water volume

$\Delta\Theta$ is the temperature difference measured

k is the thermal coefficient of water

The calculator always calculates energy in [Wh], and then it is converted into the selected measuring unit.



E [Wh] =	$V \times \Delta\Theta \times k \times 1000$
E [kWh] =	$E [\text{Wh}] / 1.000$
E [MWh] =	$E [\text{Wh}] / 1.000.000$
E [GJ] =	$E [\text{Wh}] / 277.780$
E [Gcal] =	$E [\text{Wh}] / 1.163.100$

Application types

MULTICAL® 602 operates with 9 different energy formulas, E1...E9, that are all calculated in parallel in connection with each integration no matter how the meter is configured. In connection with cooling the following energy calculations are used:

$E3 = V1(T2 - T1)$	Cooling energy (V1 in inlet or outlet)
$E8 = m^3 \times T1$	Basis for calculating volume based average temperatures in inlet
$E9 = m^3 \times T2$	Basis for calculating volume based average temperatures in outlet

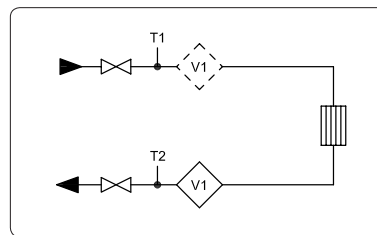

Closed thermal system with 1 flow sensor

Flow measurement

The flow indication is updated every 10 seconds.



Calculator functions

Power measurement

MULTICAL® 602 calculates current power on the basis of current water flow and the temperature difference measured in connection with the latest integration.

Current power is updated in the display simultaneously with the flow update.

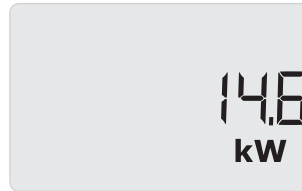

Min. and max. flow and power

MULTICAL® 602 registers minimum and maximum flow and power on a monthly as well as on a yearly basis. The registrations which appear from the display or can be read via data communication include max. and min. flow and power values, all with date indication.

All max. and min. values are calculated as largest and smallest average respectively of a number of current flow or power measurements. The average period used for all calculations is selected in the interval 1...1440 min.

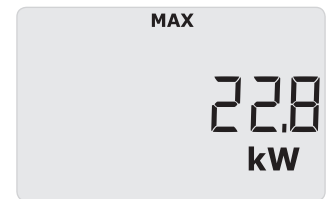

Temperature measurement

MULTICAL® 602 and ULTRAFLOW® 14 is delivered with Pt500 sensors in 2-wire versions.

The measuring circuit includes a high resolution analog/digital converter with a temperature range of 0.00...185.00 °C.

In addition to current temperatures for the energy calculation average temperatures on a yearly and monthly basis can also be displayed.

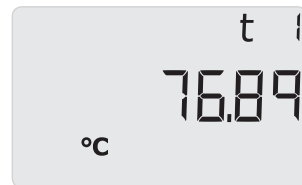

Display functions

MULTICAL® 602 is equipped with a clear LCD display including 8 digits, units of measurement and information panel. In connection with energy and volume readings 7 digits and the units of measurement to match are used, whereas 8 digits are used when e.g. meter number is read.

As a starting point the display shows accumulated energy. When the push buttons are activated the display reacts immediately by calling other readings. The display automatically returns to accumulated energy reading 4 minutes after the latest activation of the push buttons.

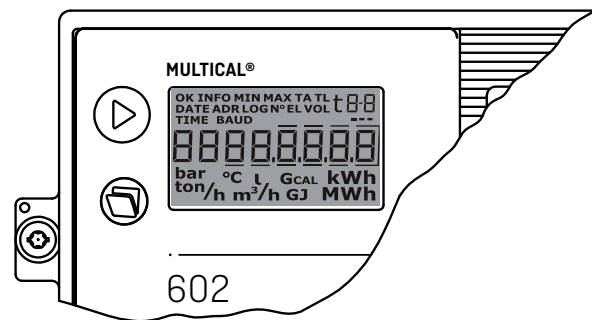

The upper push button is used to switch between the primary readings. The consumers typically use the first primary readings in connection with self-reading for billing purposes. The lower push button is used to show secondary information on the selected primary reading.

Calculator functions

Set/reset function

The set/reset function of MULTICAL® 602 makes it possible to change a number of parameters by means of the two buttons on the meter's front.

The following parameters can be changed:

- Date
- Hour
- Input A (preset of register)
- Input B (preset of register)
- Meter no. of Input A
- Meter no. of Input B
- Pulse value for Input A
- Pulse value for Input B
- Primary M-Bus address
- Operating hour counter (reset)
- Info-event counter (reset)

In order to get access to the set/reset functions, the installation seal must be broken, and thus the change can only be made by the energy supplier.

Info codes

MULTICAL® constantly monitors a number of important functions, e.g. power supply and temperature sensors. Should a serious error occur in the measuring system or in the installation, a flashing "info" will appear in the display whilst the error exists. The "Info" panel will automatically disappear when the error has been corrected.

An Info Event Logger indicates how many times the info code has been changed.

The info logger stores the latest 50 changes, of which 36 can be displayed.



Info code	Description
0	No irregularities
1	Supply voltage has been cut off
4	T2 sensor outside range, short-circuited or cut off
8	T1 sensor outside range, short-circuited or cut off

Info code	ULTRAFLOW® 14 info (active when CCC=4XX)
16	Flow sensor V1, Data communication error
2048	Flow sensor V1, wrong meter factor
4096	Flow sensor V1, signal too low (Air)
16384	Flow sensor V1, wrong flow direction

Calculator functions

Data loggers

MULTICAL® 602 contains a permanent memory (EEPROM), where the results of a number of various data loggers are stored. The meter contains the following data loggers which can be read on the display or via serial data:

Data logging interval	Data logging depth	Logged value
Yearly logger	15 years	Counter registers (as seen on the display)
Monthly logger	36 months	Counter registers (as seen on the display)
Daily logger	460 days	Consumption (increase)/day
Hourly logger	1392 hours	Consumption (increase)/hour
Programmable data logger (option)	1080 loggings Logging interval 1-1440 min. (e.g. 45 days' hour loggings or 11 days' 15 min. loggings)	Up to 40 optional registers and values
Info logger	50 events	Info code, date, time and energy (E3)

Voltage supply

MULTICAL® 602 is available with battery supply, 230 VAC mains module or 24 VAC mains module. The supply modules are exchangeable without breaking the verification seal.

Plug-in modules

Plug-in modules can be added to MULTICAL® 602 both in the calculator top (top modules) and in the base unit (base modules), in this way the meter can adapt to various applications and data reading methods.

Programming and testing

METERTOOL HCW is a Windows® -based software which includes all facilities for calculator programming. If the software is used together with VERIFICATION EQUIPMENT for MULTICAL® 602, the calculator can be tested.

Tariff functions

MULTICAL® 602 has 2 extra registers TA2 and TA3 to accumulate energy parallelly to the main register based on a programmed tariff condition. No matter which tariff type you select the tariff registers will be displayed as TA2 and TA3. The main register is always accumulated, irrespective of the selected tariff function, as it is considered the legal billing register. Tariff conditions TL2 and TL3 are monitored before each integration. If the tariff conditions are fulfilled, the consumed cooling energy is accumulated in either TA2 or TA3, as well as the main register.

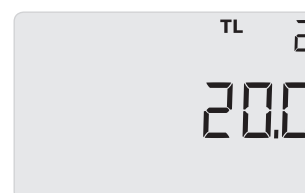

Calculator functions

Pulse outputs CE and CV

MULTICAL® 602 has pulse outputs for energy and volume pulses respectively. CE on terminals 16-17 releases one pulse per least significant digit of the energy count in the display and CV on terminals 18-19 releases one pulse per least significant digit of the volume count in the display.

If a higher resolution of pulse outputs is required, a CCC code with high resolution must be selected. The pulse outputs CE and CV are located on selected "top modules".



Pulse inputs VA and VB

MULTICAL® 602 has two extra pulse inputs, VA and VB, to collect and accumulate pulses remotely, e.g from cold-water meters and electricity meters. The pulse inputs are located on the "base modules".

The pulse inputs VA and VB function independently of the other inputs/outputs.

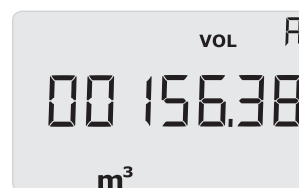

Electrical data

Typical accuracy

- Calculator	$E_c \pm [0.15 + 2/\Delta\Theta] \%$
- Sensor set	$E_T \pm [0.4 + 4/\Delta\Theta] \%$
- Flow sensor	$E_F \pm [1 + 0.01 \times q_p/q] \%$

Supply voltage

3.6 VDC \pm 0.1 VDC

Battery

3.65 VDC, D-cell lithium

Stand-by current

< 85 μ A

Replacement interval

- Mounted on wall

12+1 years @ $t_{BAT} < 30 \text{ }^\circ\text{C}$

The replacement interval is reduced when using data modules, frequent data communication or at high ambient temperature

Mains supply

230 VAC $\pm 15/-30 \%$, 50/60 Hz24 VAC $\pm 50 \%$, 50/60 Hz

Insulation voltage

4 kV

Power supply

< 1 W

Backup supply

Integral super-cap eliminates operational stop-down due to shortterm power cuts (this only applies for supply modules type 602-0000-7 and 602-0000-8).

EMC data

EN 1434 Class A. Domestic and light industrial.

Calculator data

Display

LCD - 7 [8] digits with a digit height of 7.6 mm

Resolution

9999.999 - 99999.99 - 999999.9 - 9999999

Energy units

MWh - kWh - GJ - Gcal

Temperature range

 θ : 0.01...180 $^\circ\text{C}$

Differential range

 $\Delta\Theta$: 0.01...170 K

Data logger (Eeprom)

- Standard

1392 hours, 460 days, 36 months, 15 years, 50 info codes

- Option

Data loggers with larger depth and hour interval

Clock/calendar

Clock, calendar, leap-year compensation, target date, Real time clock with battery back-up

Data communication

KMP protocol with CRC16 used for optical communication and for top and base modules

Power in temperature sensors

< 10 μ W RMS

Temperature measurement

Sensor inputs T1, T2

- Measuring range

0.00...185.00 $^\circ\text{C}$

Max. cable lengths

- Pt500, 2-wire

2 x 0.25 mm²: 10 m2 x 0.50 mm²: 20 m

Electrical data

Pulse inputs <u>without</u> bounce damping VA and VB VA: 65-66 and VB: 67-68	Water meter connection FF(VA) and GG(VB) = 71...90	Electricity meter connection FF(VA) and GG(VB) = 50...60
Pulse input	680 k Ω pull-up to 3.6 V	680 k Ω pull-up to 3.6 V
Pulse ON	< 0.4 V for > 30 msec.	< 0.4 V for > 30 msec.
Pulse OFF	> 2.5 V for > 100 msec.	> 2.5 V for > 100 msec.
Pulse frequency	< 1 Hz	< 3 Hz
Electrical isolation	No	No
Max. cable length	25 m	25 m
Requirements to external contact	Leakage current at function open < 1 μ A	

Pulse inputs <u>with</u> bounce damping VA and VB VA: 65-66 and VB: 67-68	Water meter connection FF(VA) and GG(VB) = 01...40
Pulse input	680 k Ω pull-up to 3.6 V
Pulse ON	< 0.4 V for > 200 msec.
Pulse OFF	> 2.5 V for > 500 msec.
Pulse frequency	< 1 Hz
Electrical isolation	No
Max. cable length	25 m
Requirements to external contact	Leakage current at function open < 1 μ A

Pulse outputs CE and CV	Via top module 67-0B	Via top module 602-0C
Type	Opto FET	Open collector (OB)
Pulse length	Optional 32 msec. or 100 msec.	
External voltage	5...48 VAC/VDC	5...30 VDC
Current	1...50 mA	1...10 mA
Residual voltage	$R_{ON} \leq 40 \Omega$	$U_{CE} \approx 1 \text{ V at } 10 \text{ mA}$
Electrical isolation	2 kV	2 kV
Max. cable length	25 m	25 m

Flow data

Nom. flow q_p [m ³ /h]	Nom. diameter [mm]	Meter factor * [pulses/l]	Dynamic range $q_p:q_i$	$q_s:q_p$	Flow@125 Hz ** [m ³ /h]	$\Delta p@q_p$ [bar]	Min. cut off [l/h]
1.5	DN15 & DN20	100	100:1	2:1	4.5	0.22	3
2.5	DN20	60	100:1	2:1	7.5	0.03	5
3.5	DN25	50	100:1	2:1	9	0.07	7
6	DN25	25	100:1	2:1	18	0.20	12
10	DN40	15	100:1	2:1	30	0.06	20
15	DN50	10	100:1	2:1	45	0.14	30
25	DN65	6	100:1	2:1	75	0.06	50
40	DN80	5	100:1	2:1	90	0.05	80
60	DN100	2.5	100:1	2:1	180	0.03	120
100	DN100 & DN125	1.5	100:1	2:1	300	0.07	200

* The meter factor can be seen on the label on the meter.

** Saturation flow. Max. pulse frequency is maintained at higher flow rates.

Pressure loss

Graph	Nom. flow q_p [m ³ /h]	Nom. diameter [mm]	k_v *	Q@0.25 bar [m ³ /h]
A	1.5	DN15 & DN20	3.2	1.6
B	2.5 & 3.5 & 6	DN20 & DN25	13.4	6.7
C	10 & 15	DN40 & DN50	40	20
D	25	DN65	102	51
E	40	DN80	179	90
F	60 & 100	DN100 & DN125	373	187

$$* q = k_v \times \sqrt{\Delta p}$$

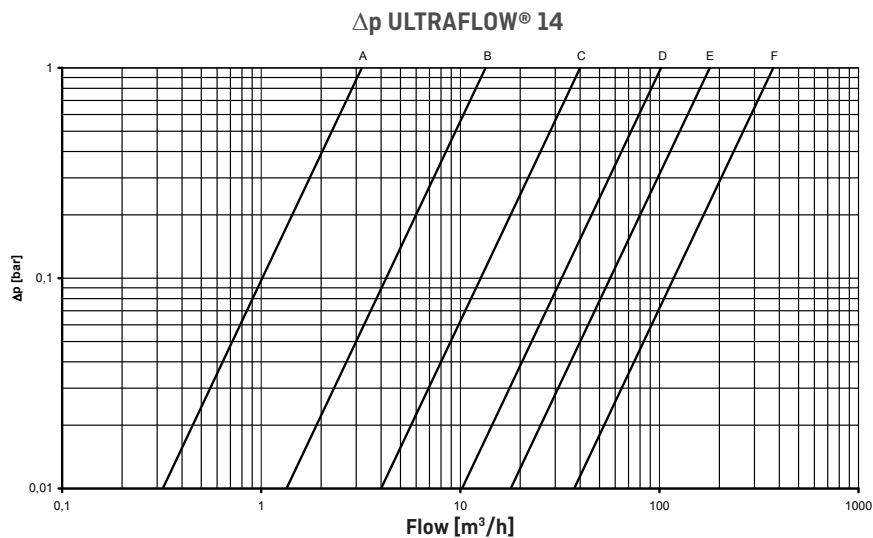

Mechanical data

Environmental class	Meets EN 1434 Class A
Ambient temperature	5...55 °C non condensing, closed location (indoor installation)
Protection class	
– Calculator	IP54
– Flow sensor	IP68
Medium in flow sensor	Water (recommended water quality as in CEN TR 16911 and AGFW FW510)
Temperature of medium	2...50 °C (At medium temperature below ambient temperature the calculator must not be mounted on the flow sensor. Instead wall-mounting is recommended.)
Storage temperature	-25...60 °C (drained flow meter)
Weight	
– MULTICAL® 602	0.4 kg excluding temperature sensors and flow sensor
– ULTRAFLOW® 14	See Dimension sketches on page 16-17
Flow sensor cable	2.5 m
(between flowpart and calculator)	Must not be removed/changed
Connection cables	ø3.5...6 mm
Supply cable	ø5...10 mm

Materials

MULTICAL® 602

Top cover	Thermoplastic, PC
Base unit	Thermoplastic, ABS with thermoplastic elastomer TPE gaskets
Print box	Thermoplastic, ABS
Wall bracket	Thermoplastic, PC 30 % GF

Wetted parts

ULTRAFLOW® 14, q_p 1.5 m³/h

– Housing, thread	DZR brass (dezincification resistant), CW602N
– Transducers	Stainless steel, W.no. 1.4401
– Gaskets	EPDM
– Reflectors	Thermoplastic, PES 30 % GF and stainless steel, W.no. 1.4301
– Measuring pipe	Thermoplastic, PES 30 % GF

ULTRAFLOW® 14, q_p 2.5 to 100 m³/h

– Housing, thread	DZR brass (dezincification resistant), CW602N
– Housing, flange	Stainless steel W.no. 1.4308
– Transducers	Stainless steel, W.no. 1.4401
– Gaskets	EPDM
– Reflectors	Stainless steel, W.no. 1.4301
– Measuring pipe	Thermoplastic, PES 30 % GF

Electronic housing

Base	Thermoplastic, PC 10 % GF
Lid	Thermoplastic, PC 20 % GF

Connection cable

Copper cable with silicone jacket and inner teflon insulation

Order specifications

MULTICAL® 602	Type 602-	□	□	□□	□	□□	□	□	□□
Sensor connection									
Pt100 2-wire (T1-T2)	A								
Pt500 2-wire (T1-T2)	C								
Top module									
No module		0							
RTC + PQ or Δt-limiter + hourly data logger		3							
RTC + data output + hourly data logger		5							
RTC + M-Bus		7							
RTC + 2 pulse outputs for CE and CV + prog. data logger		B							
2 pulse outputs CE and CV		C							
Base module									
No module			00						
Data + pulse inputs			10						
M-Bus + pulse inputs			20						
Radio Router + pulse inputs			21						
Prog. datalogger + RTC + 4...20 mA inputs + pulse inputs			22						
0/4...20 mA outputs			23						
LonWorks, FTT-10A + pulse inputs			24						
Radio + pulse inputs (internal antenna) 434 or 444 MHz			25						
Radio + pulse inputs (external antenna connection) 434 or 444 MHz			26						
M-Bus module with alternative registers + pulse inputs			27						
M-Bus module with medium data package + pulse inputs			28						
M-Bus module with MC-III data package + pulse inputs			29						
Wireless M-Bus Mode C1 + pulse inputs			30						
Wireless M-Bus Mode T1 individual key + pulse inputs			31						
Wireless M-Bus Mode C1 Alt. reg. (Individual key) + pulse inputs			35						
Wireless M-Bus Mode C1 fixed network + pulse inputs			38						
ZigBee 2.4 GHz int.ant. + pulse inputs			60						
Metasys N2 (RS485) + pulse inputs			62						
SIOX module (Auto detect Baud rate)			64						
BACnet MS/TP modul			66						
Modbus RTU + pulse inputs			67						
GSM/GPRS (GSM6H)			80						
3G GSM/GPRS module (GSM8H)			81						
Ethernet/IP (IP201)			82						
High Power Radio Router + pulse inputs			84						
Supply									
No supply			0						
Battery, D-cell			2						
230 VAC High Power isolated SMPS			3						
24 VAC High Power isolated SMPS			4						
230 VAC isolated linear supply			7						
24 VAC isolated linear supply			8						
Pt500 sensor set									
No sensor set				00					
Pocket sensor set w/1.5 m cable				0A					
Pocket sensor set w/3.0 m cable				0B					
Pocket sensor set w/5 m cable				0C					
Pocket sensor set w/10 m cable				0D					
Short direct sensor set w/1.5 m cable				0F					
Short direct sensor set w/3.0 m cable				0G					
Flow sensor/pick-up unit									
Supplied w/1 ULTRAFLOW®	(Please specify type)						1		
Meter type									
Cooling meter								5	
Heat/cooling meter								6	
Country code (language on label etc.)									XX

When placing orders please state ULTRAFLOW® type numbers separately.

Order specifications

The list below shows type numbers for ULTRAFLOW® 14

Type number *	q _p [m ³ /h]	q _i [m ³ /h]	q _s [m ³ /h]	Connection	Length [mm]	Meter factor [pulses/l]	CCC ** (high res.)	Material
65-1-CDAA -XXX	1.5	0.015	3	G¾B (R½)	110	100	419 [407]	Brass
65-1-CDAD -XXX	1.5	0.015	3	G1B (R¾)	130	100	419 [407]	Brass
65-1-CDAF -XXX	1.5	0.015	3	G1B (R¾)	190	100	419 [407]	Brass
65-1-CEAF -XXX	2.5	0.025	5	G1B (R¾)	190	60	498	Brass
65-1-CGAG -XXX	3.5	0.035	7	G5/4B (R1)	260	50	451 [436]	Brass
65-1-CHAG -XXX	6	0.06	12	G5/4B (R1)	260	25	437 [438]	Brass
65-1-CHCB -XXX	6	0.06	12	DN25	260	25	437 [438]	Stainless steel
65-1-CJAJ -XXX	10	0.1	20	G2B (R1½)	300	15	478 [483]	Brass
65-1-CJCD -XXX	10	0.1	20	DN40	300	15	478 [483]	Stainless steel
65-1-CKCE -XXX	15	0.15	30	DN50	270	10	420 [485]	Stainless steel
65-1-CLCG -XXX	25	0.25	50	DN65	300	6	479	Stainless steel
65-1-CMCH -XXX	40	0.4	80	DN80	300	5	458 [486]	Stainless steel
65-1-FACL -XXX	60	0.6	120	DN100	360	2.5	470 [487]	Stainless steel
65-1-FBCL -XXX	100	1	200	DN100	360	1.5	480 [488]	Stainless steel
65-1-FBCM -XXX	100	1	200	DN125	350	1.5	480 [488]	Stainless steel

* XXX-code pertaining to final assembly etc. is determined by Kamstrup A/S.

Some variants may not be included in national versions.

** CCC-code indicates the adaptation of MULTICAL® to the connected flow sensor type.

Accessories

Calculator

Description

D-cell battery
 230 VAC High Power isolated SMPS
 24 VAC High Power isolated SMPS
 230 VAC isolated linear supply
 24 VAC isolated linear supply
 Data cable w/USB plug
 Infrared optical reading head w/USB plug
 Infrared optical reading head w/D-sub 9F
 Data cable RS232, D-sub 9F
 Verification unit (used with METERTOOL)

Type No.

1606064
 60200003000000
 60200004000000
 60200007000000
 60200008000000
 66-99-098
 66-99-099
 66-99-102
 66-99-106
 66-99-397/-398/-399

METERTOOL HCW

66-99-724

LogView HCW

66-99-725

Temperatur sensors

Description

Change-over nipple M10 - R½ for direct short temperature sensor
 Change-over nipple M10 - R¾ for direct short temperature sensor
 Sensor pocket, length = 65 mm
 Sensor pocket, length = 90 mm
 Sensor pocket, length = 140 mm

Type No.

65-56-546
 65-56-547
 65-57-324
 65-57-327
 65-57-314

Flow sensors

Couplings including gaskets (PN16 and PN25)

Size	Nipple	Union	Type No.	
			1 pc.	2 pcs.
DN15	R½	G¾	-	6561-323
DN20	R¾	G1	-	6561-324
DN25	R1	G5/4	6561-325	-
DN40	R1½	G2	6561-315	-

Gaskets for flanged meters (PN25)

Size	Type No. (1 pc.)
DN25	2210-133
DN40	2210-132
DN50	2210-099
DN65	2210-141
DN80	2210-140
DN100	1150-142
DN125	1150-153

Gaskets for couplings (PN16 and PN25)

Size (union)	Type No. (1 pc.)
G¾	2210-061
G1	2210-062
G5/4	2210-063
G2	2210-065

Please contact Kamstrup A/S for questions concerning further accessories.

Dimensional sketches calculator

Front dimensions of MULTICAL® 602



Wall-mounted MULTICAL® 602 seen from the side

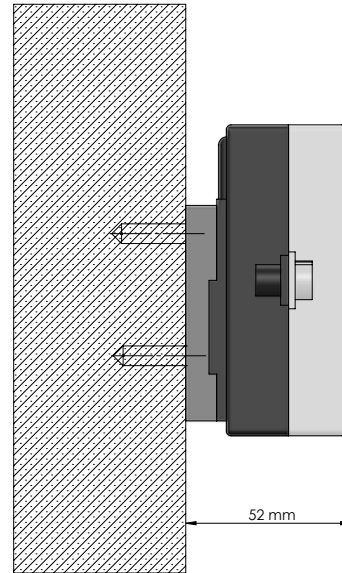

Dimensional sketches temperature sensors

Direct short sensor

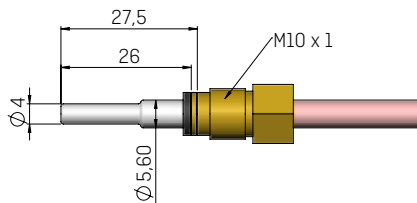

Pocket sensor

All measurements are in mm, unless otherwise stated.

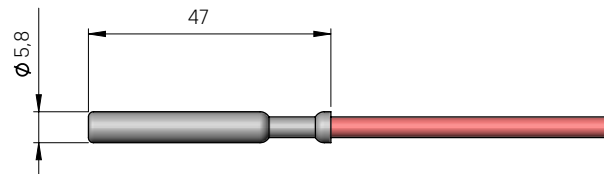

Change-over nipples for direct short sensor

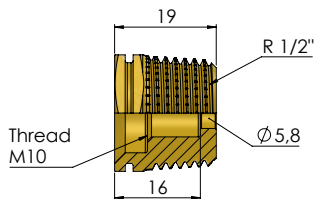

Sensor pocket

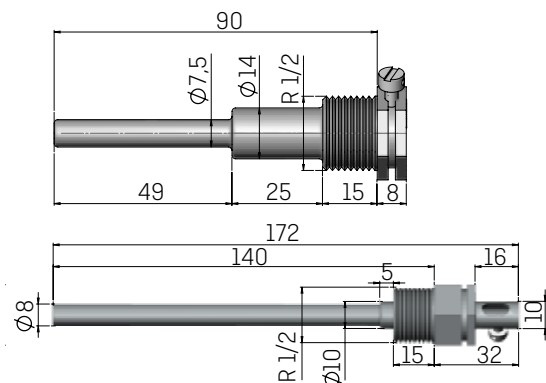
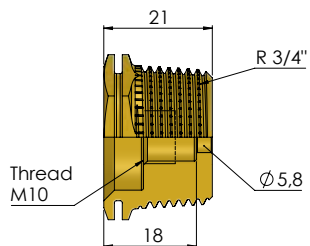
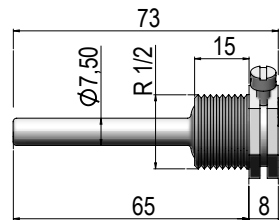

R½ and R¾ thread according to EN 10226-1

Dimensional sketches flow sensors

ULTRAFLOW® 14, G¾B and G1B

All measurements are in mm, unless otherwise stated.

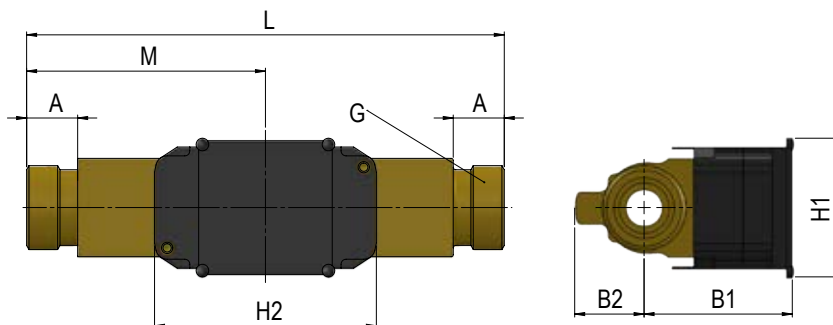

Thread EN ISO 228-1

Thread	L	M	H2	A	B1	B2	H1	App. weight [kg]
G¾B	110	L/2	89	10.5	58	35	55	0.8
G1B	130	L/2	89	20.5	58	35	55	0.9
G1B (q _p 1.5)	190	L/2	89	20.5	58	35	55	1.4
G1B (q _p 2.5)	190	L/2	89	20.5	58	36	55	1.3

ULTRAFLOW® 14, G5/4B and G2B

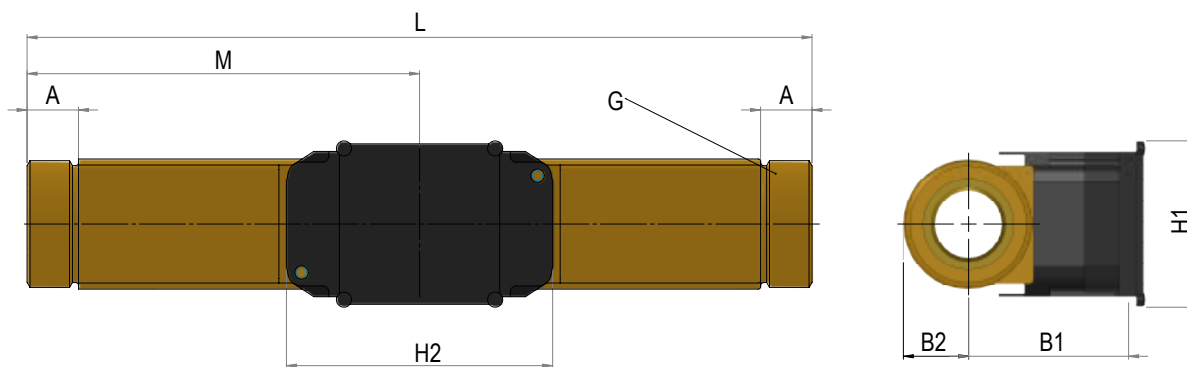

Thread EN ISO 228-1

Thread	L	M	H2	A	B1	B2	H1	App. weight [kg]
G5/4B	260	L/2	89	17	58	22	55	2.3
G2B	300	L/2	89	21	65	31	55	4.5

Dimensional sketches flow sensors

ULTRAFLOW® 14, DN25 to DN50

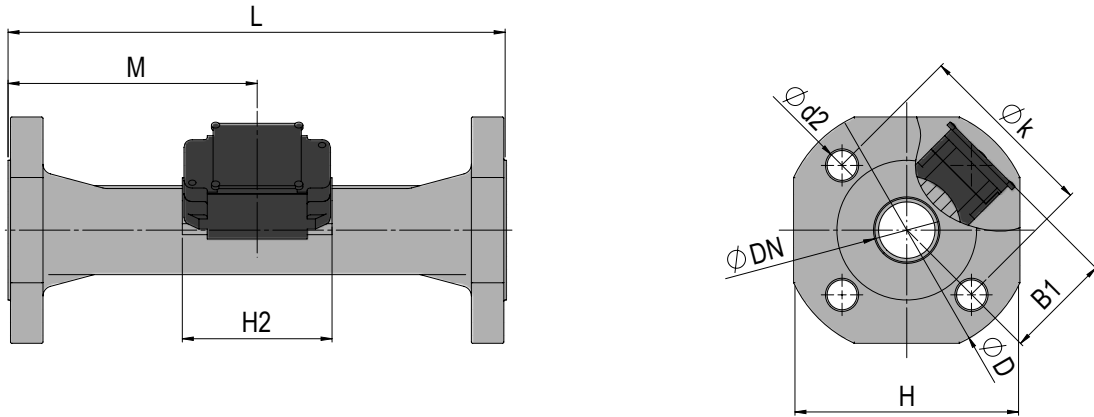

Flange facing type B, raised face according to EN 1092-1, PN25

Nom. diameter	L	M	H2	B1	D	H	k	Bolts			App. weight [kg]
								No.	Thread	d ₂	
DN25	260	L/2	89	58	115	106	85	4	M12	14	5.0
DN40	300	L/2	89	<D/2	150	136	110	4	M16	18	8.3
DN50	270	155	89	<D/2	165	145	125	4	M16	18	10.1

ULTRAFLOW® 14, DN65 to DN125

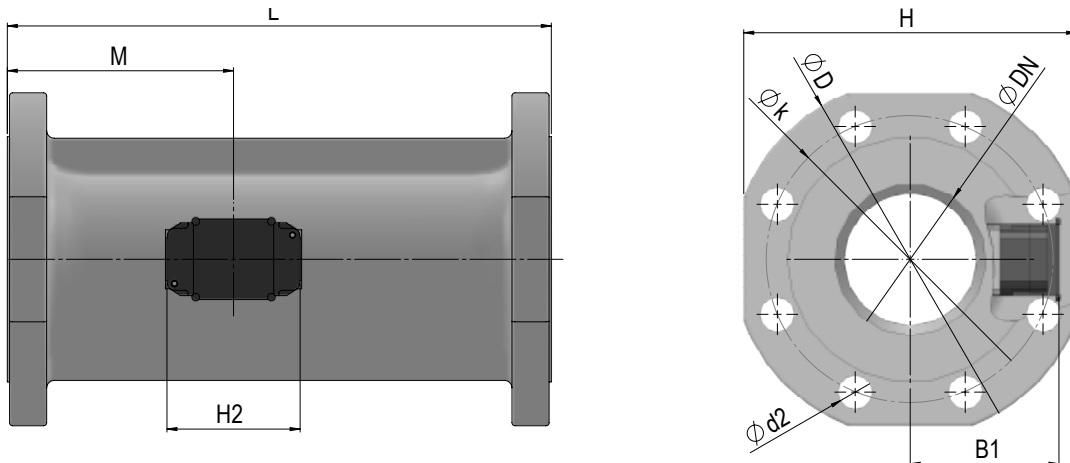

Flange facing type B, raised face according to EN 1092-1, PN25

Nom. diameter	L	M	H2	B1	D	H	k	Bolts			App. weight [kg]
								No.	Thread	d ₂	
DN65	300	170	89	<H/2	185	168	145	8	M16	18	13.2
DN80	300	170	89	<H/2	200	184	160	8	M16	18	16.8
DN100	360	210	89	<H/2	235	220	190	8	M20	22	21.7
DN125	350	212	89	<H/2	270	260	220	8	M24	26	28.2

Installation of calculator

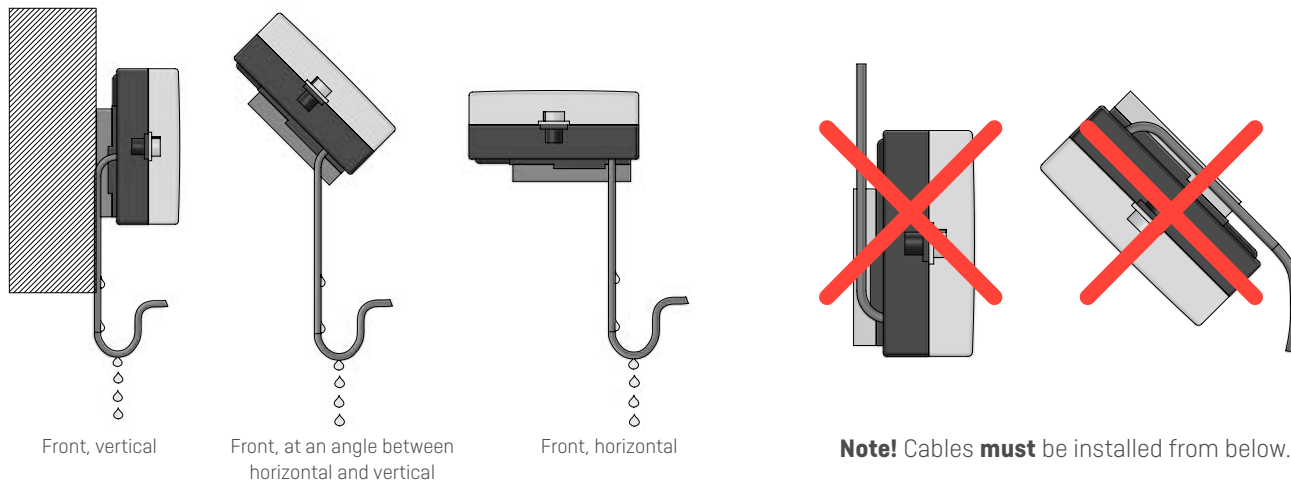

Installation example with suspension



Note:
The suspension **must** not be used on condensing pipes.
Suspension kit item no. 5915-144. Not included.

Installation of temperature sensors

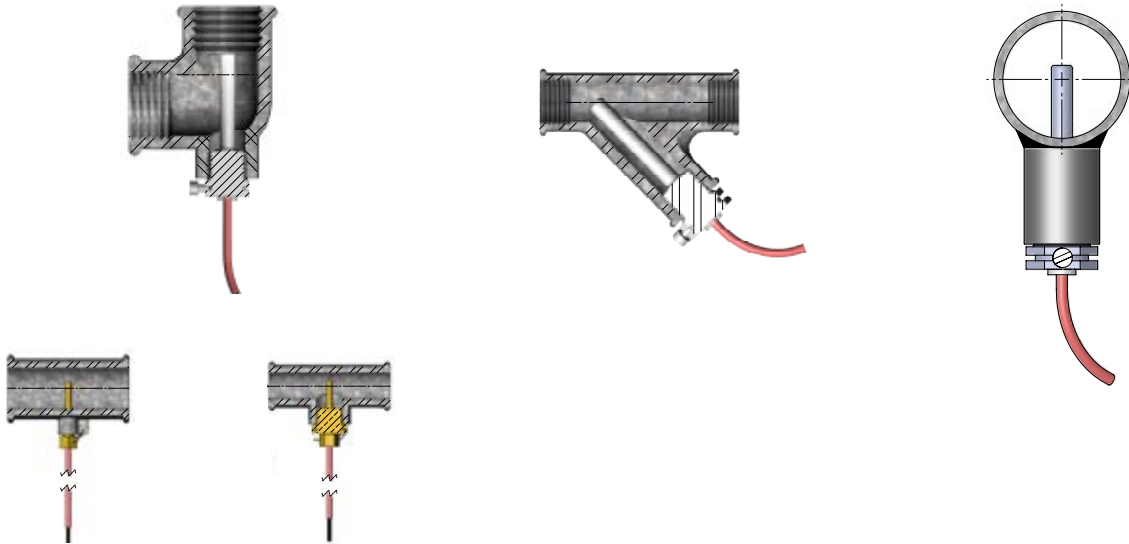

Temperature sensors must be mounted from below.

Mounting of flow sensors

Before mounting the flow sensor, flush the system thoroughly and remove protection plugs/plastic membranes from the flow sensor. Correct flow sensor position (inlet or outlet pipe) appears from the front label placed on the MULTICAL® 602. The flow direction is indicated by an arrow on the side of the flow sensor.

Couplings and gaskets must be mounted as shown on the drawing.

Straight inlet: ULTRAFLOW® 14 requires neither straight inlet nor outlet to meet the Measuring Instruments Directive (MID) 2014/32/EU, OIML R75:2002 and EN 1434:2015. Only in case of heavy flow disturbances before the meter will a straight inlet section be necessary. We recommend following the guidelines in CEN CR 13582.

To prevent cavitation, the back pressure (pressure at flow sensor outlet) at ULTRAFLOW® 14 must be min. 1.5 bar at q_p and min. 2.5 bar at q_s .

ULTRAFLOW® 14 must not be exposed to pressures below ambient pressure (vacuum).

ULTRAFLOW® 14 may be insulated. MULTICAL® 602 must not be insulated.

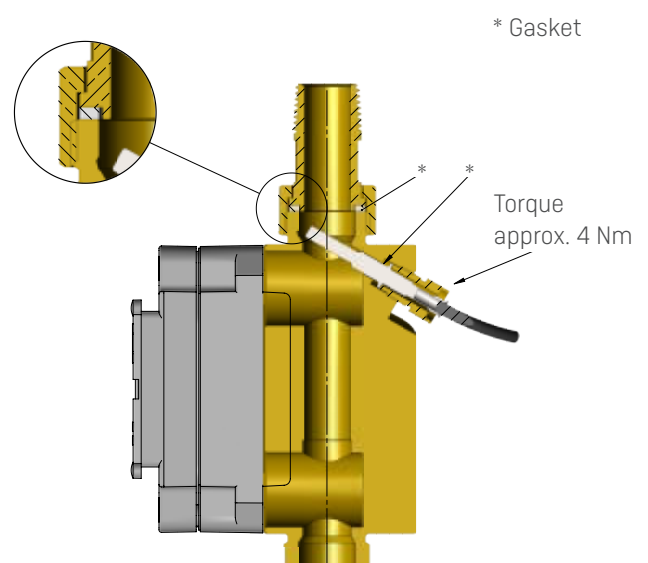

Mounting of ULTRAFLOW® 14

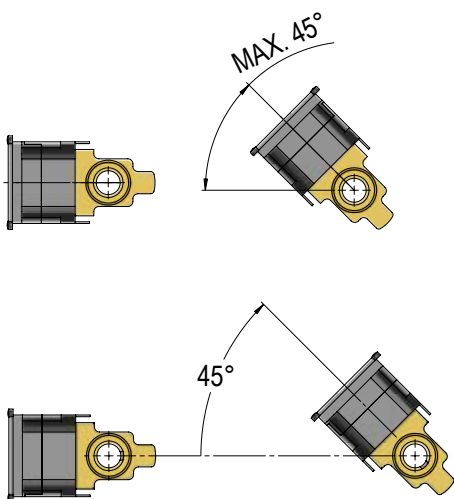
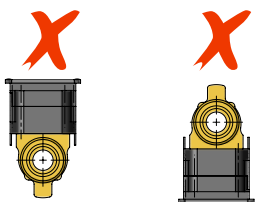
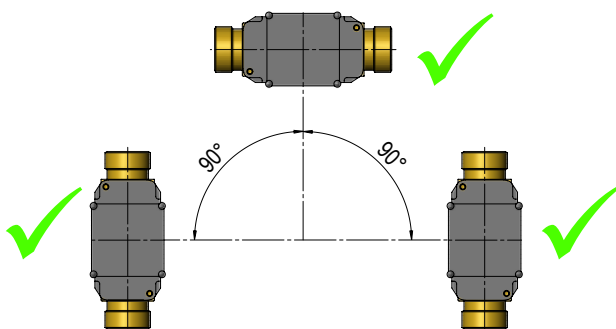

ULTRAFLOW® 14 may be installed horizontally, vertically or at an angle.

IMPORTANT!

With ULTRAFLOW® 14, the electronics/plastic case must be placed to the side (with horizontal installation).

ULTRAFLOW® 14 may be turned up to +45° around the pipe axis.

At risk of condensation, e.g. in cooling installations, or if ULTRAFLOW® 14 is installed in moist environments, ULTRAFLOW® 14 must be turned +45° around the pipe axis.

Kamstrup A/S

Industrivej 28, Stilling
DK-8660 Skanderborg
T: +45 89 93 10 00
F: +45 89 93 10 01
info@kamstrup.com
kamstrup.com