

Data sheet

• **PQT Controller**

MULTICAL® 403

MULTICAL® 603

MULTICAL® 803

- Controller for power or flow
- Possibility to further limit t_2 and Δt
- Simple setup and commissioning
- Output for three-point valve motor
- External 24 VAC supply for motor valve



Contents

Description	2
Installation	2
Cable connections	3
Connection of Belimo RV24A-MF	4
Mode of operation	5
Typical PQT installation	6
Technical data	6
Ordering	7
Configuration	7
Display readings	8

Description

HC-003-43 is a versatile control module for use in MULTICAL® 403, MULTICAL® 603 and MULTICAL® 803 energy meters. The PQT Controller is for applications to optimize energy consumption. The PQT Controller works together with the MULTICAL® energy meter and reads the meter's flow, power, temperature difference and outlet temperature. The read data is used together with the limit values configured in the module to control the connected motor valve.

The controller is fully programmable and can be selected to regulate according to one or more monitoring parameters. Normally, a power control that is controlled only according to a fixed power limit is desired. It is also possible to choose to limit according to a fixed maximum flow.

In addition to power and flow, the controller can also be configured to monitor the temperature difference and/or outlet temperature and thus further limit the final flow.

Likewise, PQT Controller can be adjusted in such a way that a minimum flow is always ensured, which avoids frost damages.

Installation

The module is installed in the meter's module slot. If there is a need for adjusting the module's configuration, this can be done by using METERTOOL HCW via the optical read-out head or by using a module programming cable.

The module is supplied by the meter's integrated 230 VAC or 24 VAC power supply. The motor valve must be supplied by a separate 24 VAC power supply.

To obtain the best control, the meter must run with the fastest possible integration time. The PQT Controller cannot be used with mechanical flow meters.

Cable connections

Terminals

Max cable size 1.5 mm²



Motor

Terminal 150: Motor Up
 Terminal 151: Motor Com
 Terminal 152: Motor Dn

Test

Short circuit to open
 Short circuit to close

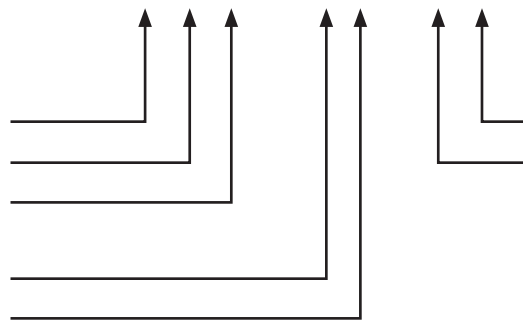

External power

Terminal 98: 24 VAC
 Terminal 97: 24 VAC

Connection diagram

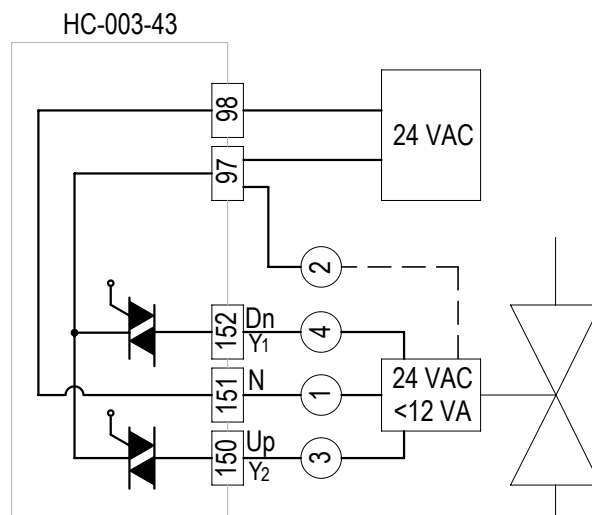

① ② ③ ④ Terminal numbers on Belimo valves

② Optional supply, e.g. RV24A-MF

When the power supply and motor valve are connected, you can test whether the valve opens and closes correctly by short-circuiting the Test-Up and Test-Dn solder pads, e.g. by using a small screwdriver.

If the valve runs in the opposite direction, the supply cables Dn Y2 and Up Y1 must be exchanged.



Connection of Belimo RV24A-MF

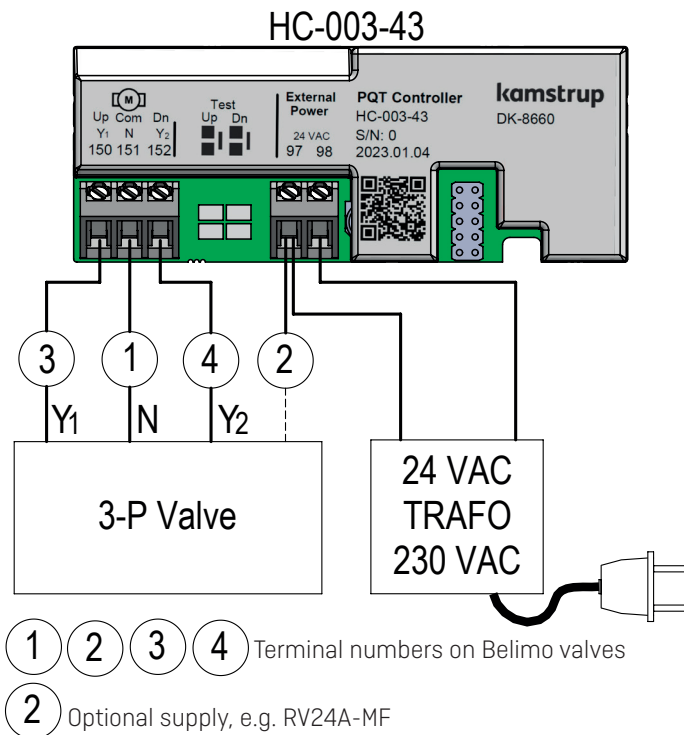

Mode of operation

PQT Controller is designed with more set-points and gain-factors. One part controls power and flow (PQ control), another part controls the outlet temperature and differential temperature (t2Δt control). The control will always adjust towards the most restrictive limit, whether it is flow, power, t2 or Δt.

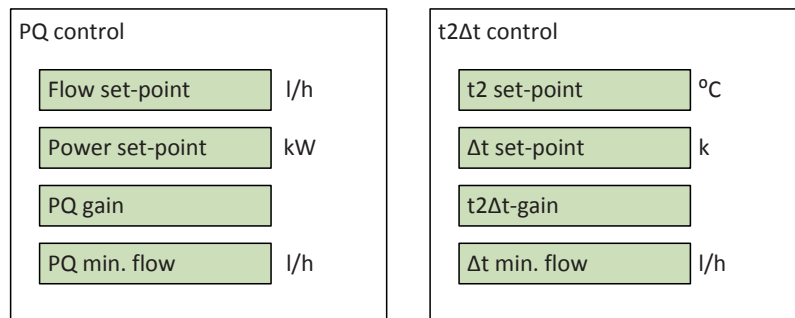

PQ control

The control of power and flow takes place in the same part of the controller as the power is calculated on the basis of flow. For the PQ control to be active, one or both set-points must be set. If set-points are set up for both flow and power, the control will at any time regulate according to the most restrictive value.

The PQ gain factor is used for adjusting the function of the controller to the actual conditions.

As a starting point, the PQ gain factor can be set to $2.5 * qp$.

Example: With a flow sensor of $qp = 60$, QP gain is set to $2.5 * 60 = 150$.

At low flow limits or low power limits, the control can steer the valve to be fully closed. For the PQ control, you can therefore choose a "PQ min. flow" that specifies the minimum allowable flow so that you can secure the installation against frost damage.

t2Δt control

The control of the temperature is set in an independent part of the controller. For the t2Δt control to be active, one or both set-points must be set. If set-points are setup for both t2 and Δt, the control will at any time regulate according to the most restrictive value.

The t2Δt gain factor is used for adjusting the function of the regulator to the actual conditions.

As a starting point, the t2Δt gain factor can be set to $qp/4$.

Example: With a flow sensor of $qp = 60$, t2Δt gain is set to $60 / 4 = 15$.

For the t2Δt control, a "Δt min. flow" can also be set. This limit indicates that there must be a minimum flow before the regulation of Δt kicks in. If there is no or very little flow, the regulation of Δt will stop.



When using the t2 setpoint please observe that:

The inlet temperature must be higher than both t2 and t2 setpoint.

If conditions are not upheld, then the meter will not invoke control on the valve.

Effectively the setpoint is disabled.

Valve control

The PQT Controller gets the current flow, power and temperatures from the meter and according to the selected set-points, the controller calculates for how long and in which direction the valve motor must run. When the control has reached its set-point, the exact control can cause rapid changes of direction on the valve motor. To protect the valve motor from these rapid changes of direction, you can set a "Min. runtime", which is the minimum time that the valve motor must run in one or the other direction.

Typical PQT installation

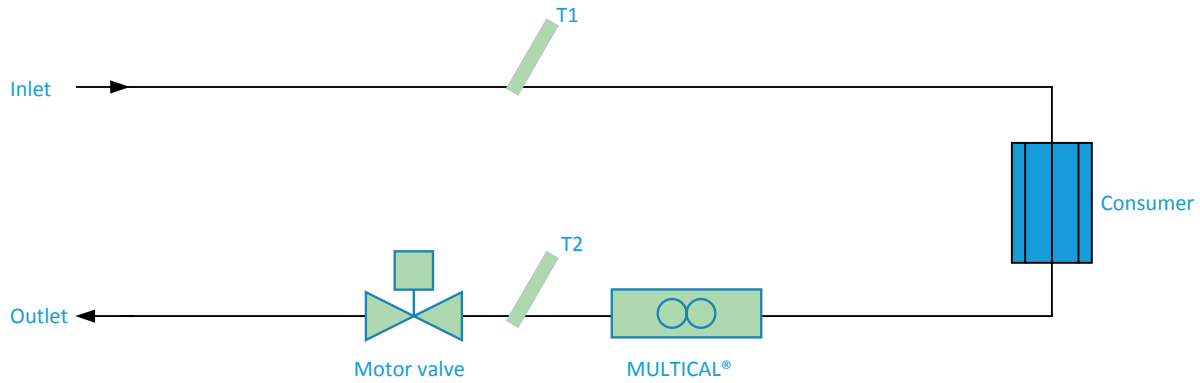

Technical data

Physical

For installation in MULTICAL® 403, MULTICAL® 603 and MULTICAL® 803.

Mechanical data

Dimensions [L x W x D] 90 x 35 x 14 mm
Weight < 45 g

MULTICAL® Supply

⚡ AC supply

Data refresh rate

Data from the meter to the module are refreshed each time the meter completes an integration. Integration mode is defined by the meter's L-code.

Dynamic range

Power 100 % ... 10 %
Flow 100 % ... 2 %

Motor Outputs

Voltage 24 VAC
Control function Three-point switch
Characteristic Linear
Valve travel time 120...460 s
Mutual blocking Yes
Short-circuit safe Yes
Galvanic isolation > 2 kV

External power

Voltage 24 VAC ±30 %
Max Power 12 VA
Max Current < 1 A

Technical data

Environment

Operational temperature	5 °C – 55 °C
Humidity	25 – 85 % RH non-condensing

Markings/ approvals

CE, MID together with the type approval of MULTICAL® 403, MULTICAL® 603 and MULTICAL® 803.

Programming

Configuration/firmware	Via the optical readout head or the multipole connector on the module using METERTOOL HCW
------------------------	---

Ordering

Order no

HC-003-43
6699 035
6699 099
6699 403
www.kamstrup.com

Description

PQT Controller
USB configuration cable for H/C-modules
Infrared optical readout head w/USB A plug
Transformer 230/24 VAC
METERTOOL HCW

Configuration

Configuration of the PQT Controller can be done when ordering or via METERTOOL HCW.

	XX	Y	Y	Z	Z	Z
Module type						
PQT module	43	0	0	1	0	0

Parameters

The following parameters can be adjusted on PQT Controller:

Flow set-point:	Sets the maximum flow.
Power set-point:	Sets the maximum power.
PQ gain:	Gain factor for power P and flow Q.
Δt set-point:	Sets the minimum allowable Δt .
t2 set-point:	Sets the maximum allowable outlet temperature.
t2Δt gain:	Gain factor for temperature limits.
Min. runtime:	The minimum allowable runtime of the motor valve.

PQT set points can also be configured through the Modbus (HC-003-67, HC-003-82) and BACnet IP (HC-003-81) modules. See the respective module datasheets for more information.

Display readings

Module information

The module information can be read by choosing "TECH loop" on the MULTICAL® meter.

Module placed in module slot 1: Choose menu 2-101 in "TECH loop"

Module placed in module slot 2: Choose menu 2-201 in "TECH loop"

Module placed in module slot 3: Choose menu 2-301 in "TECH loop"

Module placed in module slot 4: Choose menu 2-401 in "TECH loop"

The following module information is available:

Menu	Menu index	Information	Display example
2-x01	31	Module configuration	
2-x01-1	32	Module firmware and revision	
2-x01-2	33	Module serial number	
2-x01-3	48	Module control information *	

* Shows the time in milliseconds that the valve is set to run until the set point is reached. The display changes every time the meter sends new data to the controller.

A positive value indicates that the valve is opening. A negative value indicates that the valve is closing.

Kamstrup A/S

Industrivej 28, Stilling
 DK-8660 Skanderborg
 T: +45 89 93 10 00
 info@kamstrup.com
 kamstrup.com