

Insulation manual

Insulation of
TemperatureSensor 63 & 83/
Flow sensors

MULTICAL® 303 (DN15-20)

MULTICAL® 403 (DN15-50)



ULTRAFLOW® 44 (DN15-125)

ULTRAFLOW® 54 (DN15-125)

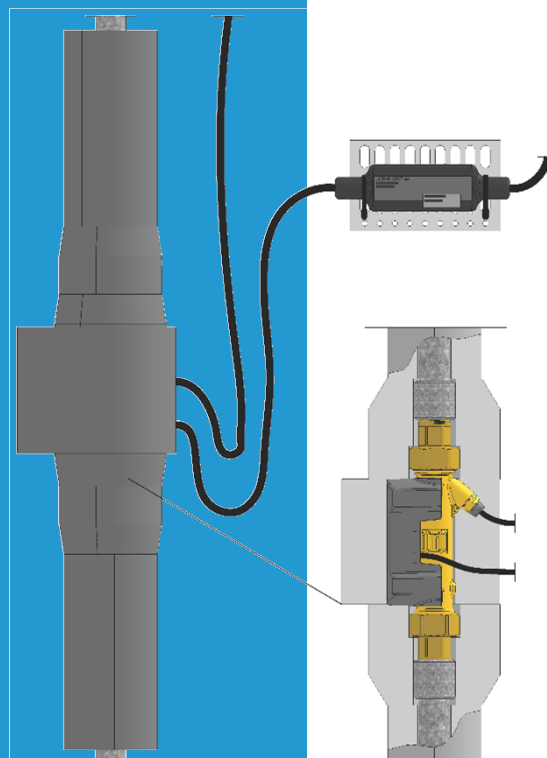
ULTRAFLOW® 54 (DN150-300)



Content

1	Introduction	4
2	Overview – Insulation recommendations for Kamstrup flow and temperature sensors	5
3	Cooling applications 	6
3.1	Examples – MULTICAL® 303 (DN15-20), MULTICAL® 403 (DN15-50)	6
3.2	Examples – ULTRAFLOW® 44 (DN15-125).....	7
3.3	Examples – ULTRAFLOW® 54 (DN15-125).....	8
3.4	Examples – ULTRAFLOW® 54 (DN150-300).....	9
4	Heat applications 	11
4.1	Examples – MULTICAL® 303 (DN15-20), MULTICAL® 403 (DN15-50)	11
4.2	Examples – ULTRAFLOW® 44 (DN15-125).....	12
4.3	Examples – ULTRAFLOW® 54 (DN15-125).....	13
4.4	Examples – ULTRAFLOW® 54 (DN150-300).....	14

1 Introduction

Insulation of pipes utilized for transmitting thermal energy conveying liquids is in general always recommended, because the insulation reduces losses of valuable heat energy or avoids heating of the medium, which is utilized for cooling. Thus, insulation optimizes the supply of thermal energy with thermal energy conveying liquids. To further optimize the supply, insulation of flow and temperature sensors, which are both in direct contact with the thermal energy conveying liquid, must also be addressed. As the calculator of a heat/cooling meter is not in direct contact with the thermal energy conveying liquid, insulation of the calculator as such is not applicable. However, due to the possibility of mounting the calculator directly on the flow sensor, installation recommendations for the calculator must be considered depending on the temperature of the medium and the environment.

Insulation has the effect, that all parts under the insulation might reach temperatures up to the temperature of the thermal energy conveying liquid as thermal balance to the environment is prohibited. This might be critical to some components, in particular to sensitive electronics. Predominantly in cooling installations, humidity from the warm environment will condense on comparatively colder pipes. This is why they are often permanently wet. Insulation therefore requires temperature stability of the insulated parts within the approved range of the medium temperature as well as waterproof encapsulation of sensitive electronic components in cooling installations in warm and humid environments. Finally, note that local rules concerning insulation of pipes might apply.

The following general rules apply for installing heat/cooling meters:

- Calculators must be wall-mounted at medium temperatures higher than 90 °C to protect sensitive electronics inside.
- Calculators usually have a lower IP-class than the connected flow sensor and must therefore NOT be mounted on the flow sensor in cooling installations to avoid condensation and water penetration into the calculator. Note, that condensation is induced from the flow sensor itself, but can also come from other parts of the installation. This becomes even more critical in warm and humid environments.
- Cable connections must always point downwards, and cables must in general hang freely downwards to form a drip nose for drainage of condensation.



Kamstrup flow sensors are only designed for water as the thermal energy conveying medium.

2 Overview – Insulation recommendations for Kamstrup flow and temperature sensors





Flow sensor	 Cooling	 Heat $T_{\text{medium}} < 110\text{ °C}$ 	 Heat $T_{\text{medium}} > 110\text{ °C}$ 
MULTICAL® 303	Yes		Yes (except the plastic case)
MULTICAL® 403			
ULTRAFLOW® 44 DN15-125			
ULTRAFLOW® 54 DN15-125	N/A	Yes (except the plastic case)	
ULTRAFLOW® 54 DN150-300	Yes (except the plastic case)		
TemperatureSensor 63 & 83	Yes		

Table 1: Overview of insulation recommendations for different flow sensors and for TemperatureSensor 63 & 83.

3 Cooling installations

3.1 Examples – MULTICAL® 303 (DN15-20), MULTICAL® 403 (DN15-50)

Flow sensors MULTICAL® 303 and MULTICAL® 403 for cooling (Type C) are particularly protected against wet conditions.

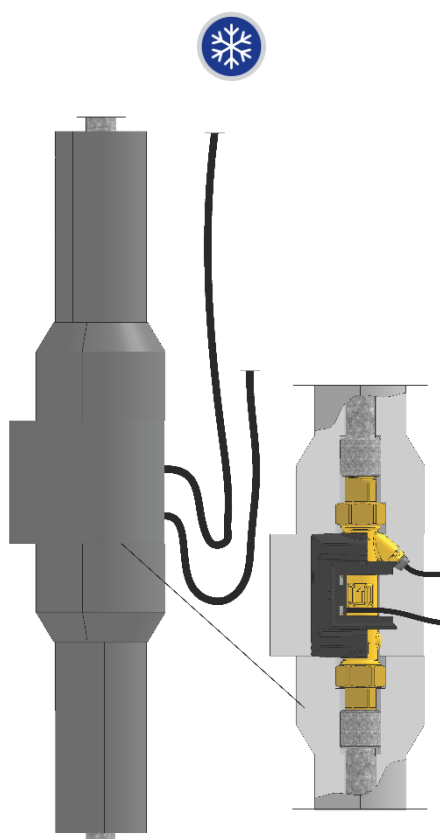

Figure 1: Insulation example of MULTICAL® 303 and MULTICAL® 403 in a cooling installation.

3.2 Examples – ULTRAFLOW® 44 (DN15-125)

The flow sensor ULTRAFLOW® 44 including the electronics box is particularly protected against wet conditions.

Nevertheless, the electronics box must NEITHER be mounted on the flow sensor NOR on pipes and due to EMC, it must NOT be mounted on cable trays, because the recommended minimum distance to other cables is 25 cm. Instead, we recommend mounting the electronics box elsewhere, e.g. fixed horizontally with cable strips on a grating. Note that thereby the type label is still visible.

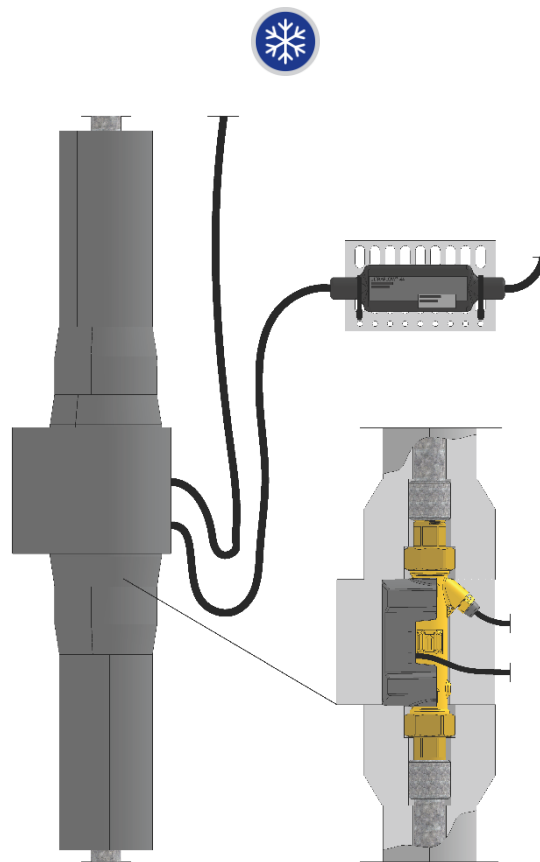

Figure 2: Insulation of ULTRAFLOW® 44 in a cooling installation.

3.3 Examples – ULTRAFLOW® 54 (DN15-125)

ULTRAFLOW® 54 (DN15-125) is designed for use in heat installations only, and for that reason neither approved nor technically suitable for cooling installations.



3.4 Examples – ULTRAFLOW® 54 (DN150-300)

The electronic's of ULTRAFLOW® 54 DN150-300 is placed in a separate black electronic's box (pos. 1) connected to the flow part (pos. 2) via an approximately 50 cm flexible steel tube (pos. 3).

The flow part (pos. 2) may be insulated. The electronic's box (pos. 1) must NOT be insulated. **This applies to both cooling and heat installations.**

If the temperature of the medium is below ambient temperature or above 90 °C, the electronics of the flow sensor must be mounted via the enclosed distance piece as shown below (Figure 3) or mounted on the wall (Figure 4). This is to avoid cold/hot radiation from the flow sensor housing causing condensation in the box/excessive heating of the electronics. Alternatively, the electronics box can be wall-mounted at a suitable distance to any cold/hot parts of the installation.

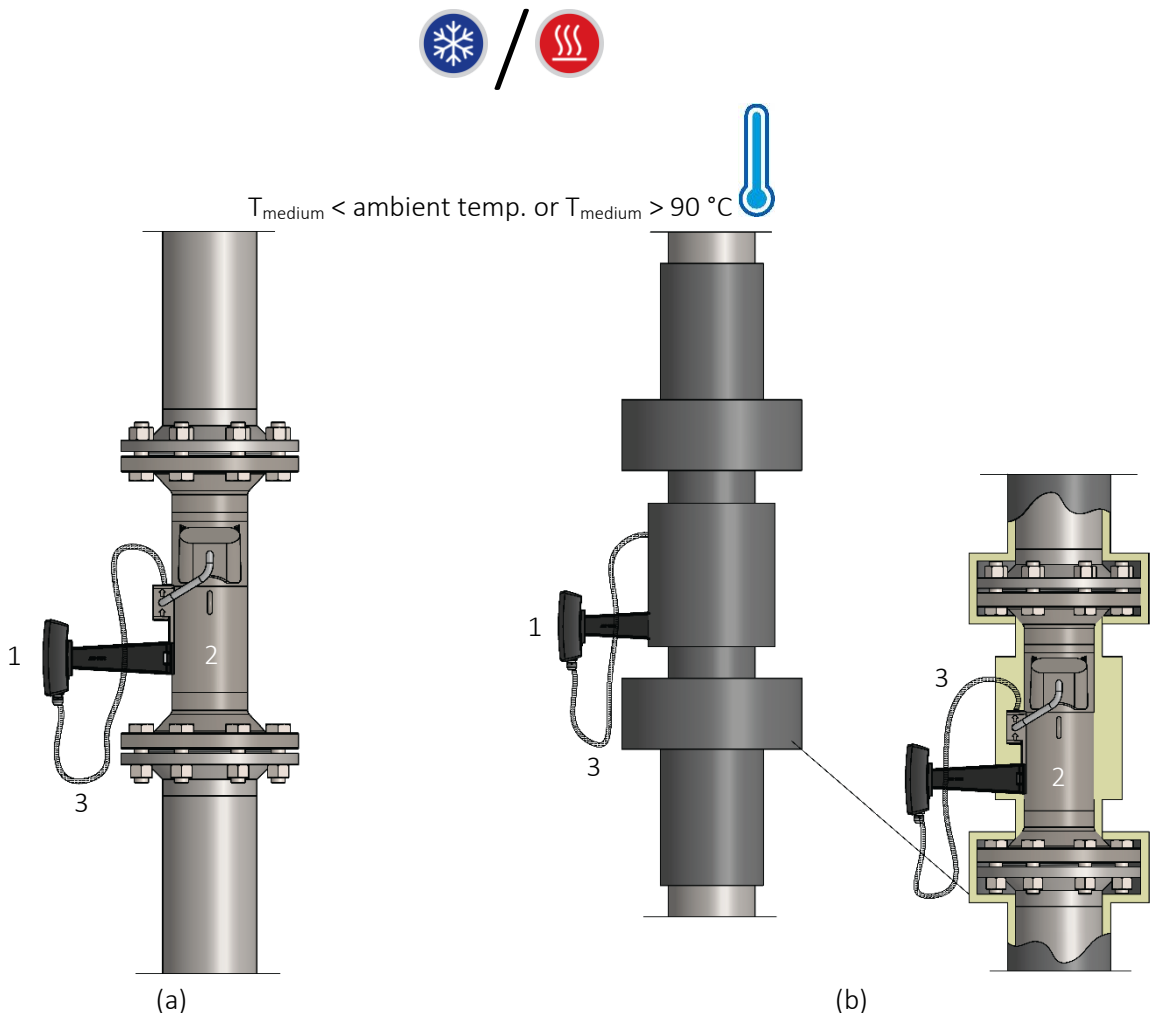

Figure 3: (a) Non-insulated ULTRAFLOW® 54 (DN150-300) at medium temperature below ambient temperature or above 90 °C. (b) Insulation of ULTRAFLOW® 54 (DN150-300). The electronics box is mounted via the enclosed distance piece.

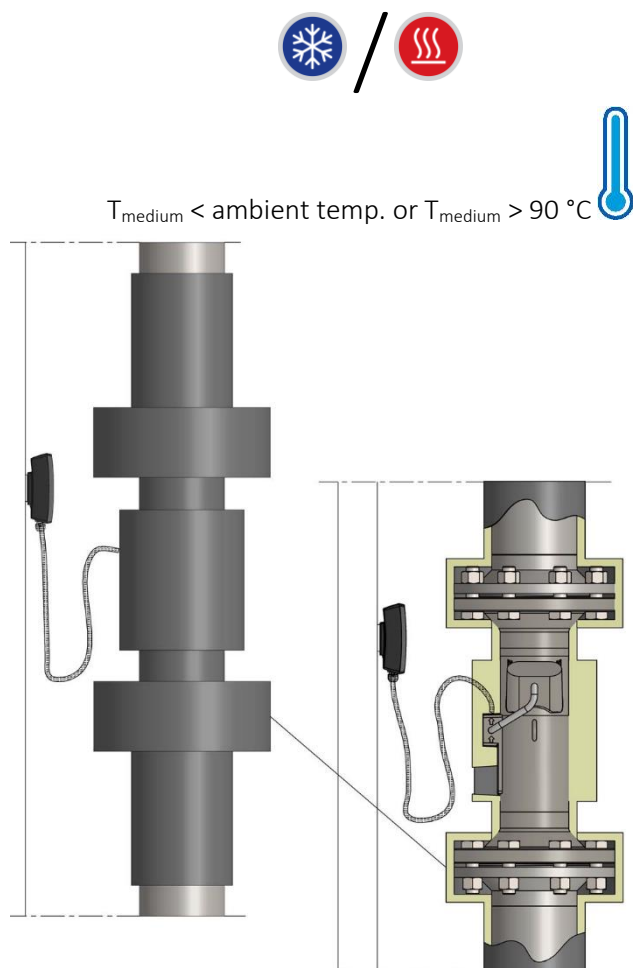



Figure 4: Insulation of ULTRAFLOW® 54 (DN150-300). The electronics box is mounted on the wall.

4 Heat installations

4.1 Examples – MULTICAL® 303 (DN15-20), MULTICAL® 403 (DN15-50)

 If the medium temperature is above 110 °C ($T_{\text{medium}} > 110 \text{ °C}$) the plastic casing must NOT be insulated. Insulation of the plastic casing at a medium temperature above 110 °C can severely damage the plastic casing, because the temperatures inside the insulation get close to the glass transition temperature of the plastic casing.

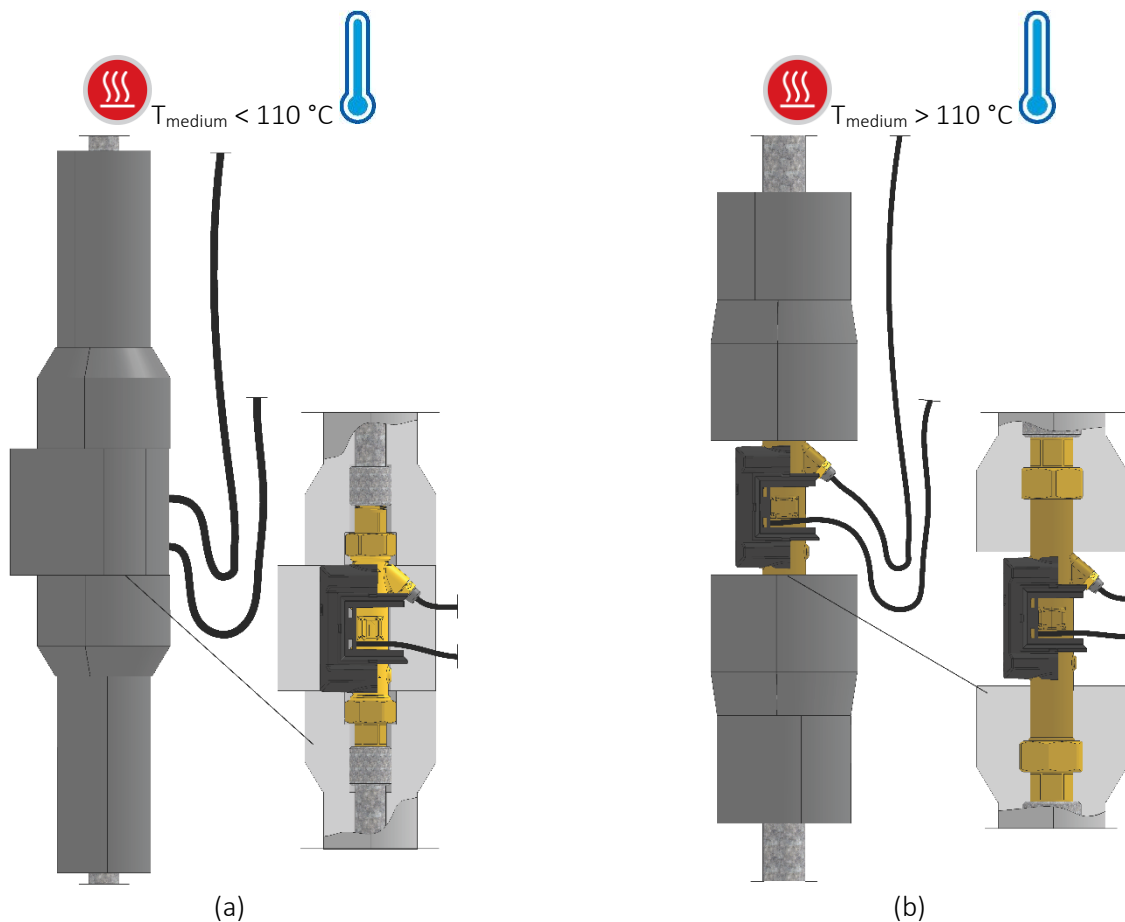

Figure 5: Insulation of flow sensors MULTICAL® 303/ MULTICAL® 403 in a heat installation (a) with $T_{\text{medium}} < 110 \text{ °C}$ and (b) with $T_{\text{medium}} > 110 \text{ °C}$.

4.2 Examples – ULTRAFLOW® 44 (DN15-125)

The electronic's box must NEITHER be mounted on the flow sensor NOR on pipes. Instead, it can hang freely on cables.

! If the medium temperature is above 110 °C ($T_{\text{medium}} > 110 \text{ °C}$), the plastic casing must NOT be insulated. Insulation of the plastic casing at a medium temperature above 110 °C can severely damage the plastic casing, because the temperatures inside the insulation get close to the glass transition temperature of the plastic casing.

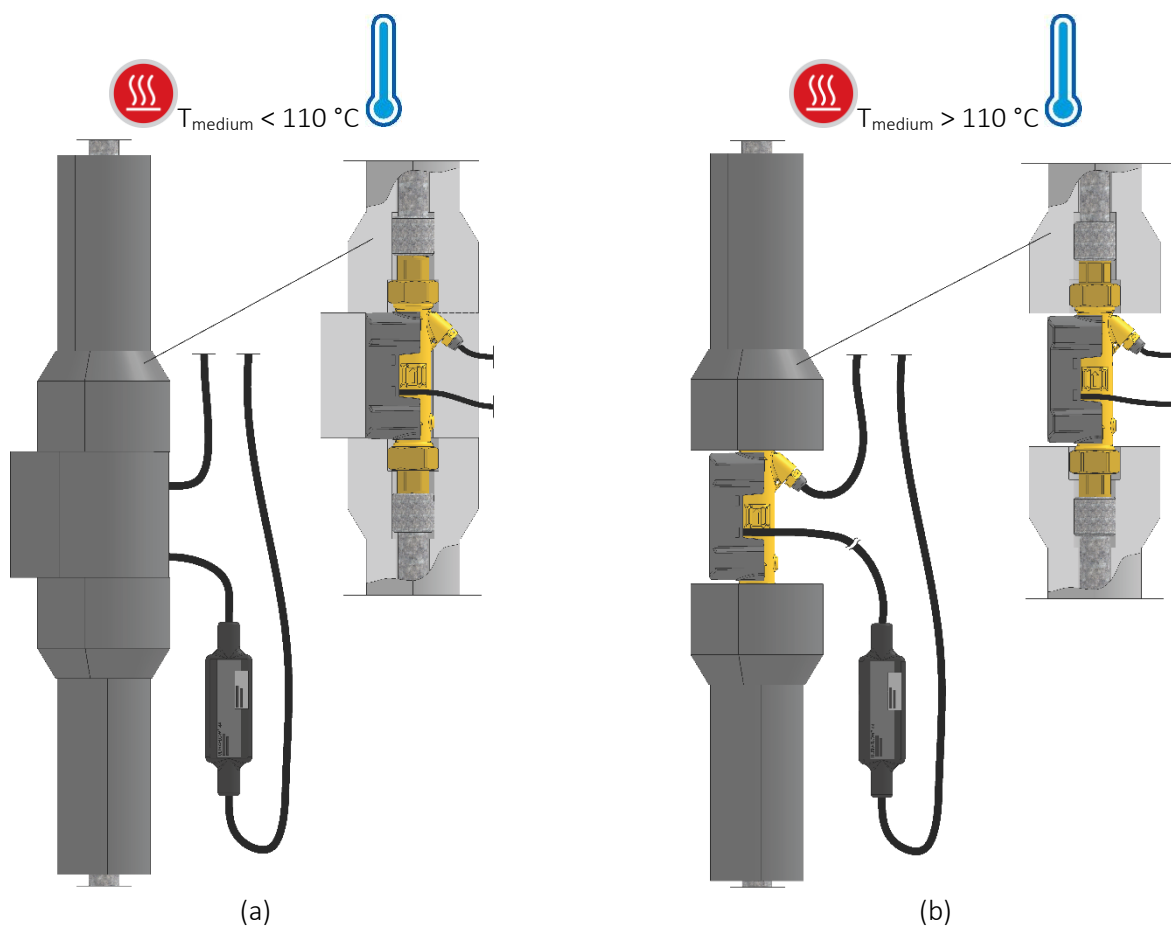



Figure 6: Insulation of ULTRAFLOW® 44 in a heat installation
(a) with $T_{\text{medium}} < 110 \text{ °C}$ and (b) with $T_{\text{medium}} > 110 \text{ °C}$.

4.3 Examples – ULTRAFLOW® 54 (DN15-125)

 The plastic casing must never be insulated. It contains sensitive electronics (flow sensor PCB), which must NOT be exposed to high temperatures. Furthermore, insulation of the plastic casing at a medium temperature above 110 °C can severely damage the plastic casing itself, because the temperatures inside the insulation get close to the glass transition temperature of the plastic casing.

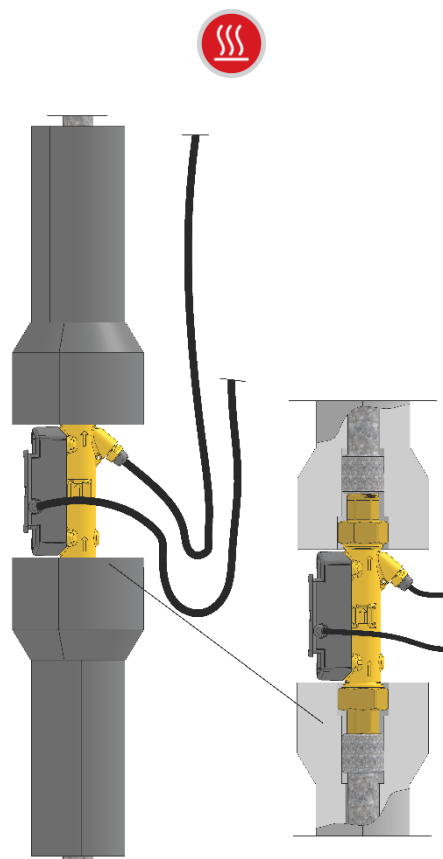

Figure 7: Insulation of ULTRAFLOW® 54 (DN15-125) in a heat installation.

4.4 Examples – ULTRAFLOW® 54 (DN150-300)

The flow part of ULTRAFLOW® 54 (DN150-300) may be insulated. The electronic's box must NOT be insulated. **This applies to both cooling and heat installations.**

For further information about insulation of ULTRAFLOW® 54 (DN150-300), see paragraph 3.4 Examples – ULTRAFLOW® 54 (DN150-300).