

Technical description

ULTRAFLOW® 44
DN15-125



Contents

| | | |
|----------|--|-----------|
| 1 | Introduction | 6 |
| 1.1 | Pioneering work and continuous development | 6 |
| 1.2 | Modular meter set-up for maximum flexibility | 6 |
| 1.3 | General description | 6 |
| 2 | Technical data | 8 |
| 2.1 | Approved meter data | 8 |
| 2.2 | Electrical data | 8 |
| 2.3 | Mechanical data | 9 |
| 2.4 | Flow data | 10 |
| 2.5 | Materials | 11 |
| 3 | Type overview | 13 |
| 4 | Ordering details | 14 |
| 4.1 | Type numbers of ULTRAFLOW® 44 | 14 |
| 4.2 | Accessories for ULTRAFLOW® | 15 |
| 4.3 | Pulse Transmitter / Pulse Divider and Cable Extender Box | 16 |
| 4.3.1 | Introduction | 16 |
| 4.3.2 | Type number composition of Pulse Transmitter and Pulse Divider | 17 |
| 4.3.3 | Output module and supply module | 17 |
| 4.3.4 | Pulse Divider configuration CCC-DD-E-MMM | 18 |
| 4.3.5 | Accessories for Pulse Transmitter and Pulse Divider | 21 |
| 4.3.6 | Cables | 21 |
| 4.3.7 | Cable Extender Box | 21 |
| 5 | Dimension sketches | 22 |
| 5.1 | Electronics box containing the PCB of ULTRAFLOW® 44 | 22 |
| 5.2 | Threaded meters | 23 |
| 5.2.1 | ULTRAFLOW® 44 (Type 65-4-XXHX-XXX) – G $\frac{3}{4}$ B and G1B | 23 |
| 5.2.2 | ULTRAFLOW® 44 (Type 65-4-XXJX-XXX) – G $\frac{5}{4}$ B, G1 $\frac{1}{2}$ B and G2B | 25 |
| 5.3 | Flange meters | 27 |
| 5.3.1 | ULTRAFLOW® 44 – DN25, DN40 and DN50 | 27 |
| 5.3.2 | ULTRAFLOW® 44 – DN65 to DN125 | 28 |
| 5.4 | Pulse Transmitter and Pulse Divider | 29 |
| 5.5 | Cable Extender Box | 30 |
| 6 | Installation | 31 |
| 6.1 | Guidelines for dimensioning and operating conditions | 31 |
| 6.1.1 | Introduction | 31 |
| 6.1.2 | Dimensioning | 32 |
| 6.1.3 | Operating conditions | 32 |
| 6.1.4 | Operating pressure | 34 |

ULTRAFLOW® 44 DN15-125

| | | |
|----------|--|----|
| 6.1.5 | Pressure loss | 35 |
| 6.2 | Connections, accessories, and assembly..... | 37 |
| 6.2.1 | Couplings and mounting of temperature sensors | 38 |
| 6.2.2 | Cable length of ULTRAFLOW® 44 | 39 |
| 6.3 | Flow sensor position (Inlet/Outlet)..... | 39 |
| 6.4 | Insulation..... | 40 |
| 6.5 | Inlet prerequisites..... | 41 |
| 6.6 | Orientation of Kamstrup’s flow sensors | 42 |
| 6.6.1 | General recommendations | 42 |
| 6.6.2 | Recommendations for heat installations | 43 |
| 6.6.3 | Recommendations for cooling and combined heat/cooling installations..... | 44 |
| 6.6.4 | Recommendations for directly mounted temperature sensors | 45 |
| 6.7 | Mounting of the electronics box of ULTRAFLOW® 44 | 46 |
| 6.8 | Mounting of Pulse Transmitter and Pulse Divider | 47 |
| 6.8.1 | Orientation of Pulse Transmitter and Pulse Divider | 47 |
| 6.8.2 | Wall-mounting of Pulse Transmitter and Pulse Divider | 47 |
| 6.9 | Mounting of Cable Extender Box | 48 |
| 6.10 | Maintenance and service during operation | 48 |
| 6.11 | Installation examples (mechanical) | 49 |
| 6.11.1 | ULTRAFLOW® 44 and MULTICAL® 603 | 49 |
| 6.11.2 | Pulse Transmitter/Pulse Divider..... | 49 |
| 6.11.3 | Insulation of ULTRAFLOW® 44 (Cooling installation)..... | 50 |
| 6.11.4 | Insulation of ULTRAFLOW® 44 (Heat installation) | 51 |
| 6.12 | Electrical connection | 52 |
| 6.12.1 | Electrical connection of ULTRAFLOW® and MULTICAL® | 52 |
| 6.12.2 | Electrical connection of Pulse Transmitter and Pulse Divider | 52 |
| 6.12.3 | Cable length | 53 |
| 6.12.4 | Connection of power supply | 55 |
| 6.12.4.1 | Battery supply..... | 55 |
| 6.12.4.2 | Mains supply modules | 55 |
| 6.12.4.3 | Mains supply cable..... | 57 |
| 6.12.4.4 | Cable screw connections | 57 |
| 6.12.4.5 | Change of supply unit | 57 |
| 6.12.5 | Electrical connection of Cable Extender Box..... | 58 |
| 6.13 | Installation examples (electrical) | 59 |
| 6.13.1 | Example of connection of ULTRAFLOW® and MULTICAL® | 59 |
| 6.13.2 | Example of connection of Pulse Transmitter | 59 |
| 6.13.3 | Calculator with two flow sensors..... | 60 |
| 6.13.4 | Electric welding..... | 61 |
| 6.14 | Operational check..... | 61 |

| | | |
|-----------|--|-----------|
| 7 | Functional description | 62 |
| 7.1 | Flow measurement with ultrasound..... | 62 |
| 7.2 | Signal path, flow calculation and flow profiles..... | 62 |
| 7.3 | Function of ULTRAFLOW® | 65 |
| 7.4 | Pulse emission..... | 66 |
| 7.5 | Supply and power consumption of ULTRAFLOW® | 66 |
| 7.6 | Pulse output of ULTRAFLOW® | 67 |
| 7.7 | Pulse output of Pulse Transmitter and Pulse Divider | 68 |
| 7.7.1 | Galvanically separated output module (Y=2) | 68 |
| 7.7.2 | Galvanically separated output module (Y=3) | 69 |
| 7.8 | Interface connector, test mode and serial data..... | 70 |
| 7.9 | Accuracy | 70 |
| 8 | Calibration, adjustment and sealing of ULTRAFLOW® | 72 |
| 8.1 | Technical data for ULTRAFLOW® | 72 |
| 8.2 | Electrical connection | 73 |
| 8.3 | Suggested test points | 74 |
| 8.4 | Optimisation in connection with calibration | 75 |
| 8.5 | Pulse Tester | 76 |
| 8.5.1 | Technical data for Pulse Tester | 76 |
| 8.5.2 | Hold function | 78 |
| 8.5.3 | Push-button functions..... | 78 |
| 8.5.4 | Use of Pulse Tester | 78 |
| 8.5.5 | Spare parts | 79 |
| 8.5.6 | Battery replacement..... | 79 |
| 8.6 | Adjustment of ULTRAFLOW® flow sensors with Kamstrup software | 80 |
| 8.6.1 | Introduction | 80 |
| 8.6.2 | Adjustment of ULTRAFLOW® 44 | 80 |
| 8.7 | Sealing and marking..... | 81 |
| 9 | Software for Kamstrup heat/cooling meters | 84 |
| 10 | Approvals..... | 85 |
| 10.1 | MID and DK-BEK 1178 – 06/11/2014 | 85 |
| 10.2 | CE marking | 85 |
| 10.3 | EU declaration of conformity | 85 |
| 11 | Troubleshooting..... | 86 |
| 12 | Disposal | 87 |
| 13 | Technical documentation | 88 |

1 Introduction

1.1 Pioneering work and continuous development

Since 1991 Kamstrup has provided static ultrasonic flow sensors for heat meters and is among the pioneering manufacturers of this technology. The stand-alone flow sensors ULTRAFLOW® are the trademark of the Kamstrup static flow sensors based on the ultrasonic measuring principle. The proven long-term accuracy and durability have gained our flow sensors a reputation of reliability and quality. Ongoing development has continuously improved the whole performance of Kamstrup flow sensors. The pressure loss has, for example been continuously reduced, while the dynamic range could still increase. Furthermore, various smart features like the ability to mount a temperature sensor in the outlet of flow sensors with sizes up to $10 \text{ m}^3/\text{h}$ have been added.

1.2 Modular meter set-up for maximum flexibility

ULTRAFLOW® is known as a separate static flow sensor. The modular composition of our heat and cooling meter set-up consisting of separate flow sensor, calculator and temperature sensor set adds degrees of flexibility to your installation, thereby accommodating most needs. In cases where separation of flow sensor and calculator is required during installation, the cable to the calculator can easily be disconnected and connected again. This cable between calculator and flow sensor is in most cases also comparatively easily changeable, underlining the intelligent and easy-to-handle design of Kamstrup products. In addition, you can exchange only one of your sub-assemblies, which minimises unforeseen costs in case of a calculator upgrade or replacement of either part. The split meter solution allows cable lengths of 2.5 m, 5 m and 10 m as standard and enables even extra-long cables of up to 110 m to MULTICAL®. For further information about our separate calculators MULTICAL® 603 and MULTICAL® 803, please see Kamstrup doc. no. FILE100002141_EN and FILE10000271_EN.

Whether you choose to install the separate ULTRAFLOW® or the flow sensors connected to our compact calculators, you can be assured by the fact that all our flow sensors are based on the same platform. The ULTRAFLOW® technology has been utilised in the basic design of our other flow sensors integrated in our compact meters like MULTICAL® 303 and MULTICAL® 403 ensuring equally proven accuracy, durability and serviceability. For further information about our compact meters MULTICAL® 303 and MULTICAL® 403, please see Kamstrup doc. no. FILE100001554_EN and FILE100000166_EN.

1.3 General description

The flow sensor program ULTRAFLOW® 44 is your preferred choice in case that your installation requires extra condensation protection (IP68). It tolerates even to be submerged up to 2 months and is therefore the answer to the demanding installations with severe environmental conditions like e.g. periodical flooding in some underground installations. It is particularly designed in combination with MULTICAL® 603 and MULTICAL® 803 and TemperatureSensor 63 or 83. The flow sensors are available in a wide range of sizes from DN15 to DN125 and flow rates from $1.5 \text{ m}^3/\text{h}$ to $100 \text{ m}^3/\text{h}$. ULTRAFLOW® 44 has been primarily designed for use in cooling installations, with water as the thermal energy conveying liquid, and can also be used for heat/cooling installations. ULTRAFLOW® 44 is not suitable for use with other media than water and should therefore not be used with e.g. non-freezing additives like glycol. Condense/water protection of ULTRAFLOW® 44 is realized by gel-encapsulated transducers and by physical removal of the flow sensors PCB from the meter housing. As the PCB itself is also waterproofed encapsulated, ULTRAFLOW® 44 withstands even temporary sub-merge (up to 2 months).

ULTRAFLOW® employs microprocessor technology. The flow is measured using bidirectional ultrasonic technique based on the transit time method. All circuits for calculating and measuring are collected on a single board, providing a compact and rational design in addition to an exceptionally high level of measuring accuracy and proven long-term stability. A three-wire signal cable is used to connect ULTRAFLOW® directly to separate MULTICAL® calculators by a cable with a length of up to 10 m. This cable is used to supply the flow sensor from the calculator and to send volume proportional pulses to the calculator.

When there is a need to extend the cable between ULTRAFLOW® and MULTICAL®, a Cable Extender Box can be used, which is mounted between ULTRAFLOW® and MULTICAL® to extend the cable length up to 30 m. Note that ULTRAFLOW® and MULTICAL® in these cases are galvanically connected. If ULTRAFLOW® shall be connected to other equipment, it must normally be connected through a Pulse Transmitter. If ULTRAFLOW® is connected to another calculator with a different meter factor than the one supplied by ULTRAFLOW®, a Pulse Divider is used instead. Pulse Transmitter and Pulse Divider are available with built-in supply for ULTRAFLOW® and the pulse outputs of both Pulse Transmitter and Pulse

Dividers are galvanically separated. In addition, Pulse Transmitter and Pulse Divider enable a cable length of up to 110 m between ULTRAFLOW® and MULTICAL®, which is required in some installations.

To achieve the easiest possible adjustment (e.g. during re-verification) we recommend to order ULTRAFLOW® 44 together with MULTICAL® 603 or MULTICAL® 803, whereby the flow sensor and the calculator will be delivered with identical serial number. Flow sensors ULTRAFLOW® 44, where the serial number of ULTRAFLOW® 44 and the connected MULTICAL® calculator is different from each other, can be considered as separately delivered. Adjustment of separately delivered ULTRAFLOW® 44 requires individual encryption keys.

2 Technical data

ULTRAFLOW® 44 DN15-125

2.1 Approved meter data

MID designation

| | |
|-----------------------------|---|
| Mechanical environment | M1 and M2 |
| Electromagnetic environment | E1 and E2 |
| Climatic environment | 5...55 °C, condensing, closed location (indoors installation) |
| Accuracy class | 2 and 3 |

EN 1434 designation

| | |
|---|--------------------------------|
| Environmental class | C |
| Fast response meter (sub-assembly flow sensor) | Volume sampling interval ≤ 2 s |

2.2 Electrical data

| | | |
|---|---|--------------------------|
| Internal supply voltage | 3.6 VDC ±0.1 VDC | |
| Battery (Pulse Transmitter/ Pulse Divider) | 3.65 VDC, D-cell lithium | |
| Battery lifetime (replacement interval) | 6 years @ $t_{BAT} < 30\text{ °C}$ | With output module (Y=3) |
| Mains supply (Pulse Transmitter/ Pulse Divider) | 230 VAC +15/-30 %, 50 Hz 24 VAC ±50 %, 50 Hz | |
| Power consumption (mains supply) | < 1 W | |
| Backup mains supply | Integral SuperCap eliminates interruptions due to short-term power failures | |
| Cable length | | |
| Flow sensor | Max 10 m | |
| Pulse Transmitter/ Pulse Divider | Depending on calculator. Max 100 m when connected to MULTICAL® (Y = 2) | |
| Cable Extender Box | Depending on calculator. Max 30 m when connected to MULTICAL® 603 or 803 | |
| Electromagnetic environment | Fulfils EN 1434 class C, MID E1 and E2 | |

2.3 Mechanical data

| | | |
|---|--|---|
| Accuracy class | 2 and 3 | |
| Electromagnetic environment | Fulfil EN 1434 class C, MID E1 and E2 | |
| Mechanical environment | MID M1 and M2 | |
| Ambient conditions | 5...55 °C, closed location (installation indoors) | |
| Protection class | | |
| Flow sensor | IP68 | When properly installed. |
| Pulse Transmitter/ Pulse Divider | IP67 | See paragraph 6 <i>Installation</i> . |
| Cable Extender Box | IP 65 | |
| Medium in flow sensor | Water – recommended water quality as described in CEN TR 16911 and AGFW FW510 | |
| Temperature of medium θ_q | 2...130 °C or narrower range (depending on configuration; see marking) | At medium temperatures above 90°C, the use of flange meters is recommended. At medium temperatures above 90 °C or below the ambient temperature, the calculator and Pulse Transmitter/Pulse Divider must not be mounted on the flow sensor. Instead, wall mounting is recommended. |
| Storage and transport temperature, empty sensor | -25...60 °C | |
| Pressure stage | PN16, PS16 or PN25, PS25 or PN16/PN25, PS25 (depending on type and configuration; see marking) | |
| Straight inlet requirement | OD (according to EN 1434) ¹ | |
| Installation angle | Horizontally, vertically and at an angle | |

¹ EN 1434:2007/AC:2007, EN 1434:2015+A1:2018 and EN 1434:2022

2.4 Flow data

| Nominal flow q_p [m ³ /h] | Meter factor ¹⁾ [p/l] | Dynamic range $q_p:q_i$ | $q_s:q_p$ | Flow@125 Hz ²⁾ [m ³ /h] | Min. cut off [l/h] |
|---|-------------------------------------|----------------------------|-----------|--|-----------------------|
| 1.5 | 100 | 100:1 | 2:1 | 4.5 | 3 |
| 2.5 | 60 | 100:1 | 2:1 | 7.5 | 5 |
| 3.5 | 50 | 100:1 | 2:1 | 9 | 7 |
| 6 | 25 | 100:1 | 2:1 | 18 | 12 |
| 10 | 15 | 100:1 | 2:1 | 30 | 20 |
| 15 | 10 | 100:1 | 2:1 | 45 | 30 |
| 25 | 6 | 100:1 | 2:1 | 75 | 50 |
| 40 | 5 | 100:1 | 2:1 | 90 | 80 |
| 60 | 2.5 | 100:1 | 2:1 | 180 | 120 |
| 100 | 1.5 | 100:1 | 2:1 | 300 | 200 |

¹⁾ The meter factor appears from the type label.

²⁾ Saturation flow 125 Hz. Max. pulse frequency is maintained at higher flow.

Table 1. Flow data

2.5 Materials

Wetted parts

ULTRAFLOW® 44, q_p 1.5 and 2.5 m³/h

| | |
|--------------------------|--|
| Housing, threaded | DZR brass (dezincification resistant brass), CW602N, to be discontinued in 2024. CW511L with max 0.1% Pb, to be implemented in 2024. |
| Blind plug | DZR brass (dezincification resistant brass), CW614N, to be discontinued in 2024. CW510L with max 0.1% Pb, to be implemented in 2024. |
| Transducer (membrane) | Stainless steel, W. no. 1.4404 |
| O-ring | Ethylene Propylene (EPDM) |
| Reflector base/Reflector | Thermoplastic, 30 % glass fibre reinforced Polyethersulfone (PESU 30 % GF) and stainless steel, similar to AISI 304 or AISI 316 |
| Measuring tube | Thermoplastic, Polyethersulfone (PESU) |

ULTRAFLOW® 44, q_p 3.5...100 m³/h

| | |
|---|---|
| Housing, threaded | DZR brass (dezincification resistant brass), CW602N, to be discontinued in 2024. CW511L with max 0.1% Pb, to be implemented in 2024. |
| Housing, flanged | Stainless steel, W. no. 1.4308 |
| Blind plug (q_p 3,5...10 m ³ /h) | DZR brass (dezincification resistant brass), CW614N, to be discontinued in 2024. CW510L with max 0.1% Pb, to be implemented in 2024. |
| Transducer (membrane) | Stainless steel, W. no. 1.4404 |
| O-ring | Ethylene Propylene (EPDM) |
| Reflector base/Reflector | Thermoplastic, 30 % glass fibre reinforced Polyethersulfone (PESU 30 % GF) and stainless steel, similar to AISI 304 – (q_p 6.0 and 10 m ³ /h)/ Stainless steel, similar to AISI 304 or AISI 316 – (q_p 3.5, 15...100 m ³ /h) |
| Measuring tube | Thermoplastic, 30 % glass fibre reinforced Polyethersulfone (PESU 30 % GF) |

Electronics housings, ULTRAFLOW® 44

q_p 1.5...100 m³/h

| | |
|---------|---|
| PCB box | Thermoplastic, Polyolefin (inside)/ Polyamide (outside) |
|---------|---|

q_p 1.5 and 2.5 m³/h

| | |
|-------------------------|--|
| Base (flow sensor) | Thermoplastic, 30 % glass fibre reinforced Polyethersulfone (PESU 30 % GF) |
| Top cover (flow sensor) | Thermoplastic, 10 % glass fibre reinforced Polycarbonate (PC 10 % GF) |

$q_p \geq 3.5$ m³/h

| | |
|---------------------|---|
| Base (flow sensor) | Thermoplastic, 10 % glass fibre reinforced Polycarbonate (PC 10 % GF) |
| Cover (flow sensor) | Thermoplastic, 10 % glass fibre reinforced Polycarbonate (PC 10 % GF) |

Housing, Pulse Transmitter/Pulse Divider

| | |
|-------------|---|
| Base, cover | Thermoplastic, 10 % glass fibre reinforced Polycarbonate (PC 10 % GF) |
|-------------|---|

ULTRAFLOW® 44 DN15-125

Cables

| | |
|--|---|
| Coaxial cable | Copper cable with silicon jacket and inner Fluoropolymer insulation |
| Signal cable | Silicone cable (3 x 0.25 mm ²) |
| Mains supply cable 24/230 VAC (optional when selecting mains-supplied Pulse Transmitter/ Pulse Divider) | Cable with Polyvinylchloride (PVC)-mantle (2 x 0.75 mm ²) |

Housing, Cable Extender Box

| | |
|-------------|--|
| Base, cover | Thermoplastic, Acrylonitrile butadiene styrene (ABS) |
|-------------|--|

3 Type overview

| Nominal flow q_p [m ³ /h] | Installation dimensions | | |
|---|--------------------------|---------------------------|-------------|
| | 1.5 | G $\frac{3}{4}$ Bx110 mm | G1Bx130 mm |
| 2.5 | G1Bx190 mm | | |
| 3.5 | G $\frac{5}{4}$ Bx260 mm | | |
| 6 | G $\frac{5}{4}$ Bx260 mm | G1 $\frac{1}{2}$ Bx260 mm | DN25x260 mm |
| 10 | G2Bx300 mm | DN40x300 mm | |
| 15 | DN50x270 mm | | |
| 25 | DN65x300 mm | | |
| 40 | DN80x300 mm | | |
| 60 | DN100x360 mm | | |
| 100 | DN100x360 mm | DN125x350 mm | |

Table 2. Type overview of ULTRAFLOW® 44

Thread EN ISO 228-1

“Flange facing type B, raised face” in accordance with EN 1092-1, PN25

4 Ordering details

4.1 Type numbers of ULTRAFLOW® 44

Threaded connection PN16/PN25, PS25¹⁾

| Type number ²⁾ | q _p [m³/h] | q _i [m³/h] | q _s [m³/h] | Dynamic range q _p :q _i | Connection | Length [mm] | PN, PS | Meter factor [p/l] | Material Housing | Temperature sensor (M10x1 connection) ³⁾ |
|---------------------------|--------------------------|--------------------------|--------------------------|---|------------|----------------|-----------|-----------------------|---------------------|--|
| 65-4- CDHA -XXX | 1.5 | 0.015 | 3 | 100:1 | G¾B (R½) | 110 | 16/25, 25 | 100 | Brass | TS63 |
| 65-4- CDHD -XXX | 1.5 | 0.015 | 3 | 100:1 | G1B (R¾) | 130 | 16/25, 25 | 100 | Brass | TS63 |
| 65-4- CEHF -XXX | 2.5 | 0.025 | 5 | 100:1 | G1B (R¾) | 190 | 16/25, 25 | 60 | Brass | TS63 |
| 65-4- CGJG -XXX | 3.5 | 0.035 | 7 | 100:1 | G5/4B (R1) | 260 | 16/25, 25 | 50 | Brass | TS63 |
| 65-4- CHJG -XXX | 6 | 0.06 | 12 | 100:1 | G5/4B (R1) | 260 | 16/25, 25 | 25 | Brass | TS63 |
| 65-4- CHJH -XXX | 6 | 0.06 | 12 | 100:1 | G1½B(R1½) | 260 | 16/25, 25 | 25 | Brass | TS63 |
| 65-4- CJJJ -XXX | 10 | 0.1 | 20 | 100:1 | G2B (R1½) | 300 | 16/25, 25 | 15 | Brass | DS38 |

¹⁾ Thread according to EN ISO 228-1 (flow sensor) and EN 10226-1 (couplings).

²⁾ XXX - code for final assembly, approvals etc. - determined by Kamstrup. A few variants may not be available in single markets.

Contact your local Kamstrup sales representative, if a variant is of interest for you.

³⁾ Direct mounting of a temperature sensor in the outlet of the flow sensor is possible. TS63 = TemperatureSensor 63 = DS27.5 mm, ø5.0 mm and ø5.2 mm; DS38 = DirectShort 38 mm

Table 3. Type numbers of ULTRAFLOW® 44, threaded connection PN16/PN25, PS25.

Flanged connection PN16/PN25, PS25¹⁾

| Type number ²⁾ | q _p [m³/h] | q _i [m³/h] | q _s [m³/h] | Dynamic range q _p :q _i | Connection | Length [mm] | PN, PS | Meter factor [p/l] | Material Housing | Temperature sensor (M10x1 connection) ³⁾ |
|---------------------------|--------------------------|--------------------------|--------------------------|---|------------|----------------|-----------|-----------------------|---------------------|--|
| 65-4- CHLB -XXX | 6 | 0.06 | 12 | 100:1 | DN25 | 260 | 16/25, 25 | 25 | Stainless steel | TS63 |
| 65-4- CJLD -XXX | 10 | 0.1 | 20 | 100:1 | DN40 | 300 | 16/25, 25 | 15 | Stainless steel | DS38 |
| 65-4- CKCE -XXX | 15 | 0.15 | 30 | 100:1 | DN50 | 270 | 16/25, 25 | 10 | Stainless steel | N/A |
| 65-4- CLCG -XXX | 25 | 0.25 | 50 | 100:1 | DN65 | 300 | 16/25, 25 | 6 | Stainless steel | N/A |
| 65-4- CMCH -XXX | 40 | 0.4 | 80 | 100:1 | DN80 | 300 | 16/25, 25 | 5 | Stainless steel | N/A |

¹⁾ Flange facing type B, raised face in accordance with EN 1092-1, PN25. Up to and inclusive DN80 mating dimensions of PN16 and PN25 are identical.

²⁾ XXX - code for final assembly, approvals etc. - determined by Kamstrup. A few variants may not be available in single markets.

Contact your local Kamstrup sales representative, if a variant is of interest for you.

³⁾ Direct mounting of a temperature sensor in the outlet of the flow sensor is possible. TS63 = TemperatureSensor 63 = DS27.5 mm, ø5.0 mm and ø5.2 mm; DS38 = DirectShort 38 mm

Table 4. Type numbers of ULTRAFLOW® 44, flanged connection PN16/PN25, PS25.

Flanged connection PN25, PS25¹⁾

| Type number ²⁾ | q _p [m³/h] | q _i [m³/h] | q _s [m³/h] | Dynamic range q _p :q _i | Connection | Length [mm] | PN, PS | Meter factor [p/l] | Material Housing | Temperature sensor (M10x1 connection) ³⁾ |
|---------------------------|--------------------------|--------------------------|--------------------------|---|------------|----------------|--------|-----------------------|---------------------|--|
| 65-4- FACL -XXX | 60 | 0.6 | 120 | 100:1 | DN100 | 360 | 25, 25 | 2.5 | Stainless steel | N/A |
| 65-4- FBCL -XXX | 100 | 1 | 200 | 100:1 | DN100 | 360 | 25, 25 | 1.5 | Stainless steel | N/A |
| 65-4- FBCM -XXX | 100 | 1 | 200 | 100:1 | DN125 | 350 | 25, 25 | 1.5 | Stainless steel | N/A |

¹⁾ Flange facing type B, raised face in accordance with EN 1092-1, PN25.

²⁾ XXX - code for final assembly, approvals etc. - determined by Kamstrup. A few variants may not be available in single markets.

Contact your local Kamstrup sales representative, if a variant is of interest for you.

³⁾ Direct mounting of a temperature sensor in the outlet of the flow sensor is possible.

Table 5. Type numbers of ULTRAFLOW® 44, flanged connection PN25, PS25.

By separate order of ULTRAFLOW® and MULTICAL®, see also the Technical descriptions of MULTICAL® 602/603/801/803 (5512-931_GB/FILE100002141_EN/5512-571_GB/FILE100000271_EN) for information on valid CCC codes in the calculator.

☀ To achieve the easiest possible adjustment (e.g. during re-verification), we recommend to order ULTRAFLOW® 44 together with MULTICAL® 603 or MULTICAL® 803, whereby the flow sensor and the calculator will be delivered with identical serial number. Flow sensors ULTRAFLOW® 44, where the serial number of ULTRAFLOW® 44 and the connected MULTICAL® calculator is different from each other, can be considered as separately delivered. Adjustment of separately delivered ULTRAFLOW® 44 requires individual encryption keys.

For further information, please see paragraphs 8.6 Adjustment of ULTRAFLOW® flow sensors with Kamstrup software.

4.2 Accessories for ULTRAFLOW®

To supplement the meter program, Kamstrup can per order deliver couplings and gaskets as accessories. All couplings and gaskets for couplings as well as flange gaskets up to and including DN80 are suitable for both PN16 and PN25. Flange gaskets DN100 and DN125 are suitable for PN25 only due to their physical dimension. Gaskets and couplings are not marked with the pressure stage.

☀ Accessories are not necessarily relevant to all flow sensors in the ULTRAFLOW® X4 product range.

| Couplings PN16/PN25 | | | | |
|---------------------|--------|-------|----------|----------|
| Size | Nipple | Union | Type No. | |
| | | | 1 pc. | 2 pcs. |
| DN15 | R½ | G¾ | - | 6561-323 |
| DN20 | R¾ | G1 | - | 6561-324 |
| DN25 | R1 | G5/4 | 6561-325 | - |
| DN32 | R5/4 | G1½ | 6561-314 | - |
| DN40 | R1½ | G2 | 6561-315 | - |

Table 6. Couplings including gaskets (PN16/PN25).

| Gaskets for couplings PN16/PN25 | | Gaskets for flange meters PN25 | |
|------------------------------------|----------|-----------------------------------|----------|
| Size (union) | Type No. | Size | Type No. |
| G¾ | 2210-061 | DN20 | 2210-147 |
| G1 | 2210-062 | DN25 | 2210-133 |
| G5/4 | 2210-063 | DN32 | 2210-217 |
| G1½ | 2210-064 | DN40 | 2210-132 |
| G2 | 2210-065 | DN50 | 2210-099 |
| | | DN65 | 2210-141 |
| | | DN80 | 2210-140 |
| | | DN100 | 1150-142 |
| | | DN125 | 1150-153 |

Table 7. Separate gaskets for couplings and flange meters (PN16/PN25).

| Article number | Description | Note |
|----------------|--|--|
| 2101-147 | Blind plug for ULTRAFLOW® | Excl. o-ring 1150-132 |
| 1150-132 | O-ring for blind plug 2101-147 | |
| 2210-131 | Fibre gasket for Pt500 short direct temperature sensor DS 27.5 mm type 6600-0XX-XXX, 1 pc. | |
| 2210-233 | Fibre gasket for TemperatureSensor 63 short direct temperature sensor DS 27.5 mm, 1 pc. | Can also be utilized for Kamstrup short direct temperature sensor type 6600-0XX-XXX. |
| 3026-858 | Angle bracket for ULTRAFLOW® 54 | For type 65-5-XXHX-XXX |
| 3026-252 | Angle bracket for ULTRAFLOW® 54 | For type 65-5-XXAX-XXX, 65-5-XXCX-XXX and 65-5-XXJX-XXX up to and including DN32. |
| 6561-332 | Short distance piece | For type 65-5-XXAX-XXX, 65-5-XXCX-XXX and 65-5-XXJX-XXX in combination with 3026-252 for > DN32. |

Table 8. Accessories for ULTRAFLOW®

4.3 Pulse Transmitter / Pulse Divider and Cable Extender Box

4.3.1 Introduction

Depending on the installation of ULTRAFLOW®, galvanic separation, adaptation of meter factor to a foreign calculator or a longer cable between ULTRAFLOW® and MULTICAL® can become necessary. Pulse Transmitter, Pulse Divider and Cable Extender Box are electronic equipment that are installed between ULTRAFLOW® and the calculator and provide various technical solutions for these purposes.

☀ To achieve the easiest possible adjustment (e.g. during re-verification) we recommend to order ULTRAFLOW® 44 together with MULTICAL® 603 or MULTICAL® 803, whereby the flow sensor and the calculator will be delivered with identical serial number. Flow sensors ULTRAFLOW® 44, where the serial number of ULTRAFLOW® 44 and the connected MULTICAL® calculator is different from each other, can be considered as separately delivered. Adjustment of separately delivered ULTRAFLOW® 44 requires individual encryption keys.

For further information, please see paragraphs *8.6 Adjustment of ULTRAFLOW® flow sensors with Kamstrup software.*

Pulse Transmitter and Pulse Divider are available with built-in supply for ULTRAFLOW®. By default, Pulse Transmitter/Pulse Divider is supplied by a built-in battery. Alternatively, Pulse Transmitter/Pulse Divider is externally supplied by 24 VAC or 230 VAC.

Pulse Transmitter and Pulse Divider are available with galvanically separated output module. See paragraph 4.3.3 below.

Galvanic separation can be used in the following situations:

- 1) If a cable length of more than 10 m is required between MULTICAL® and ULTRAFLOW®
- 2) For flow sensor no. 2 in connection with MULTICAL®. If two flow sensors are used together with MULTICAL® and an equipotential connection between the two flow sensors cannot be carried out, one (typically V2) should be galvanically separated.

For further information, see paragraph *6.13.3 Calculator with two flow sensors.*

- 3) If ULTRAFLOW® is connected to other equipment/foreign calculators, ULTRAFLOW® must be galvanically separated.
- 4) In cases where the electronic signal between ULTRAFLOW® and MULTICAL® is disturbed, galvanic separation in the Pulse Transmitter may in some cases remedy the problem.

☀ Due to the galvanic separation, flow-info is not available if Pulse Transmitter or Pulse Divider is used.

When mounting the Pulse Transmitter or Pulse Divider between ULTRAFLOW® and MULTICAL®, the cable length can be extended up to 100 m depending on the calculator. See paragraphs 4.3.2, 4.3.3 and 6.12.3 for more information.

In the case where galvanic separation is not necessary and flow-info is required, the Cable Extender Box enables an extension of the cable length between ULTRAFLOW® and MULTICAL® of up to max 30 m. For more information, see paragraph 4.3.7.

4.3.2 Type number composition of Pulse Transmitter and Pulse Divider

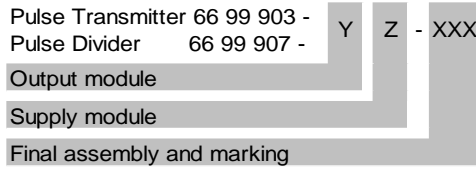

4.3.3 Output module and supply module

| Y | Output module | Corresponding supply module |
|---|--|-----------------------------|
| 2 | Galvanically separated module | 0, 7, 8 |
| 3 | Galvanically separated module, low power | 0, 2, 7, 8 |

| Z | Supply module | Corresponding output module |
|---|-----------------------|-----------------------------|
| 0 | No supply | 2, 3 |
| 2 | Battery, D-cell | 3 |
| 7 | 230 VAC supply module | 2, 3 |
| 8 | 24 VAC supply module | 2, 3 |

Table 9. Output module (Y) and supply module (Z) for Pulse Transmitter and Pulse Divider.

Pulse Transmitter and Pulse Divider are available with one of two different galvanically separated output modules.

Output module (Y=2) is used when extra-long cables are required. When connecting to MULTICAL®, a DC supply is required as shown in *Figure 29* to *Figure 32*, pages 53 and 54 (see also the Technical description of MULTICAL®, Flow sensor with active 24 V pulse output). For output module (Y=2), battery supply is not an option.

Output module (Y=3) is intended for battery supply with a minimum battery life of 6 years. Output module (Y=3) is selected by default.

When Pulse Transmitter and Pulse Divider are mains-supplied (24 VAC or 230 VAC) and connected via 3-wire cable to MULTICAL®, both output modules can be used. See *Figure 27* and *Figure 28*, pages 53 and 53, respectively.

For further information, see paragraph 6.12.2 *Electrical connection of Pulse Transmitter and Pulse Divider*.

4.3.4 Pulse Divider configuration CCC-DD-E-MMM

If ULTRAFLOW® is connected to calculators with different meter factor than the one supplied by ULTRAFLOW®, a Pulse Divider is used.

Pulse Divider must be configured in accordance with Table 10 for the respective ULTRAFLOW® meter factor (CCC), which is unique for the nominal flow q_p . The desired meter factor (DD) and pulse duration (E) of the Pulse Divider is then determined by the connected calculator. MMM indicates selection of customer label.

| q_p [m³/h] | CCC | Meter factor | | | | Pulse duration | | | | |
|-----------------|------------|--------------|-----------|---------|----|----------------|------------|------------|------------|----------------|
| | | [pulses/l] | [l/pulse] | Divider | DD | [ms] (E=1) | [ms] (E=4) | [ms] (E=5) | [ms] (E=6) | |
| 0.6 | 116 | 300 | | | | 3.9 | - | - | - | Default |
| 0.6 | | | 1 | 300 | 33 | - | 20 | 50 | 100 | |
| 0.6 | | | 2.5 | 750 | 63 | - | - | - | 100 | |
| 1.5 | 119 | 100 | | | | 3.9 | - | - | - | Default |
| 1.5 | | | 1 | 100 | 33 | - | 20 | 50 | 100 | |
| 1.5 | | | 2.5 | 250 | 63 | - | - | - | 100 | |
| 1.5 | | | 10 | 1000 | 34 | - | - | - | 100 | |
| 2.5 | 198 | 60 | | | | 3.9 | - | - | - | Default |
| 2.5 | | | 1 | 60 | 33 | - | 20 | 50 | 100 | |
| 2.5 | | | 2.5 | 150 | 63 | - | - | - | 100 | |
| 2.5 | | | 10 | 600 | 34 | - | - | - | 100 | |
| 3.5 | 151 | 50 | | | | 3.9 | - | - | - | Default |
| 3.5 | | | 1 | 50 | 33 | - | 20 | 50 | - | |
| 3.5 | | | 2.5 | 125 | 63 | - | - | - | 100 | |
| 3.5 | | | 10 | 500 | 34 | - | - | - | 100 | |
| 3.5 | | | 25 | 1250 | 64 | - | - | - | 100 | |
| 6 | 137 | 25 | | | | 3.9 | - | - | - | Default |
| 6 | | | 1 | 25 | 33 | - | 20 | 50 | - | |
| 6 | | | 2.5 | 62.5 | 63 | - | - | - | 100 | |
| 6 | | | 10 | 250 | 34 | - | - | - | 100 | |
| 6 | | | 25 | 625 | 64 | - | - | - | 100 | |
| 10 | 178 | 15 | | | | 3.9 | - | - | - | Default |
| 10 | | | 1 | 15 | 33 | - | 20 | 50 | - | |
| 10 | | | 10 | 150 | 34 | - | - | - | 100 | |
| 10 | | | 25 | 375 | 64 | - | - | - | 100 | |
| 15 | 120 | 10 | | | | 3.9 | - | - | - | Default |
| 15 | | | 1 | 10 | 33 | - | 20 | - | - | |
| 15 | | | 10 | 100 | 34 | - | - | 50 | 100 | |
| 15 | | | 25 | 250 | 64 | - | - | - | 100 | |
| 15 | | | 100 | 1000 | 35 | - | - | - | 100 | |
| 25 | 179 | 6 | | | | 3.9 | - | - | - | Default |
| 25 | | | 1 | 6 | 33 | - | 20 | - | - | |
| 25 | | | 10 | 60 | 34 | - | - | 50 | 100 | |
| 25 | | | 25 | 150 | 64 | - | - | - | 100 | |
| 25 | | | 100 | 600 | 35 | - | - | - | 100 | |

Table 10. Configuration variants of meter factor (DD) and pulse duration (E) for Pulse Divider for ULTRAFLOW® X4, q_p 0.6...25 m³/h. Note that flow sensors with q_p 0.6 are not created for ULTRAFLOW® 44.

☀ To achieve the easiest possible adjustment (e.g. during re-verification) we recommend to order ULTRAFLOW® 44 together with MULTICAL® 603 or MULTICAL® 803, whereby the flow sensor and the calculator will be delivered with identical serial number. Flow sensors ULTRAFLOW® 44, where the serial number of ULTRAFLOW® 44 and the connected MULTICAL® calculator is different from each other, can be considered as separately delivered. Adjustment of separately

delivered ULTRAFLOW® 44 requires individual encryption keys. For further information, please see paragraph 8.6 *Adjustment of ULTRAFLOW® flow sensors with Kamstrup software.*

Based on a q_p -value, one of the meter factor options for the Pulse Divider is selected from *Table 10*. The pulse duration options appear from the same line as the selected meter factor.

Example: For ULTRAFLOW® X4 with q_p 1.5 m³/h (100 imp/l, CCC=119), a meter factor of 1 l/pulse (DD=33) for the Pulse Divider is required. Based on this meter factor, you have the option of pulse durations 20 (E=4), 50 (E=5) or 100 (E=6) milliseconds.

| q_p [m ³ /h] | CCC | Meter factor | | | | Pulse duration | | | | |
|------------------------------|------------|--------------|-----------|---------|----|----------------|------------|------------|------------|----------------|
| | | [pulses/l] | [l/pulse] | Divider | DD | [ms] (E=1) | [ms] (E=4) | [ms] (E=5) | [ms] (E=6) | |
| 40 | 158 | 5 | | | | 3.9 | - | - | - | Default |
| 40 | | | 10 | 50 | 34 | - | 20 | 50 | - | |
| 40 | | | 25 | 125 | 64 | - | - | - | 100 | |
| 40 | | | 100 | 500 | 35 | - | - | - | 100 | |
| 40 | | | 250 | 1250 | 65 | - | - | - | 100 | |
| 60 | 170 | 2,5 | | | | 3.9 | - | - | - | Default |
| 60 | | | 10 | 25 | 34 | - | 20 | 50 | - | |
| 60 | | | 25 | 62.5 | 64 | - | - | - | 100 | |
| 60 | | | 100 | 250 | 35 | - | - | - | 100 | |
| 60 | | | 250 | 625 | 65 | - | - | - | 100 | |
| 100 | 180 | 1,5 | | | | 3.9 | - | - | - | Default |
| 100 | | | 10 | 15 | 34 | - | 20 | 50 | - | |
| 100 | | | 100 | 150 | 35 | - | - | - | 100 | |
| 100 | | | 250 | 375 | 65 | - | - | - | 100 | |

Table 11. Configuration variants of meter factor (DD) and pulse duration (E) for Pulse Divider for ULTRAFLOW® X4, q_p 40...100 m³/h.

Default values in *Table 10* and *Table 11* indicate meter factors and pulse durations of ULTRAFLOW® X4.

| q_p [m ³ /h] | CCC | Meter factor | | | | Pulse duration | | | | |
|------------------------------|------------|--------------|-----------|---------|-----------|----------------|------------|------------|------------|-----------------|
| | | [pulses/l] | [l/pulse] | Divider | DD | [ms] (E=1) | [ms] (E=4) | [ms] (E=5) | [ms] (E=6) | |
| 0,6 | 116 | 300 | | | 70 | 3.9 | - | - | - | Standard |
| 0,6 | | | 0,0167 | 5 | 41 | 3,9 | - | - | - | |
| 0,6 | | | 0,02 | 6 | 51 | 3,9 | - | - | - | |
| 0,6 | | | 0,04 | 12 | 12 | 3,9 | - | - | - | |
| 1,5 | 119 | 100 | | | 31 | 3.9 | - | - | - | Standard |
| 1,5 | | | 0,02 | 2 | 51 | 3,9 | - | - | - | |
| 1,5 | | | 0,04 | 4 | 12 | 3,9 | - | - | - | |
| 1,5 | | | 0,1 | 10 | 32 | 3,9 | - | - | - | |
| 2,5 | 198 | 60 | | | 41 | 3.9 | - | - | - | Standard |
| 2,5 | | | 0,0667 | 4 | 22 | 3,9 | - | - | - | |
| 2,5 | | | 0,1 | 6 | 32 | 3,9 | - | - | - | |
| 3,5 | 151 | 50 | | | 51 | 3.9 | - | - | - | Standard |
| 3,5 | | | 0,04 | 2 | 12 | 3,9 | - | - | - | |
| 3,5 | | | 0,1 | 5 | 32 | 3,9 | - | - | - | |

Table 12. Configuration variants for meter factor (DD) and pulse length (E) with fixed dividers for MULTICAL® 603 installations with two ULTRAFLOW® X4 sensors of different sizes. Note that flow sensors with q_p 0.6 are not created for ULTRAFLOW® 44.

ULTRAFLOW® 44 DN15-125

| q _p [m³/h] | CCC | Meter factor | | | | Pulse duration | | | | |
|--------------------------|------------|--------------|-----------|---------|-----------|----------------|------------|------------|------------|-----------------|
| | | [pulses/l] | [l/pulse] | Divider | DD | [ms] (E=1) | [ms] (E=4) | [ms] (E=5) | [ms] (E=6) | |
| 0,6 | 116 | 300 | | | 70 | 3,9 | - | - | - | Standard |
| 0,6 | | | 0,0033 | 1 | 70 | 3,9 | - | - | - | |
| 1,5 | 119 | 100 | | | 31 | 3,9 | - | - | - | Standard |
| 1,5 | | | 0,01 | 1 | 31 | 3,9 | - | - | - | |
| 2,5 | 198 | 60 | | | 41 | 3,9 | - | - | - | Standard |
| 2,5 | | | 0,0167 | 1 | 41 | 3,9 | - | - | - | |
| 3,5 | 151 | 50 | | | 51 | 3,9 | - | - | - | Standard |
| 3,5 | | | 0,02 | 1 | 51 | 3,9 | - | - | - | |
| 6 | 137 | 25 | | | 12 | 3,9 | - | - | - | Standard |
| 6 | | | 0,04 | 1 | 12 | 3,9 | - | - | - | |
| 10 | 178 | 15 | | | 22 | 3,9 | - | - | - | Standard |
| 10 | | | 0,0667 | 1 | 22 | 3,9 | - | - | - | |
| 15 | 120 | 10 | | | 32 | 3,9 | - | - | - | Standard |
| 15 | | | 0,1 | 1 | 32 | 3,9 | - | - | - | |
| 25 | 179 | 6 | | | 42 | 3,9 | - | - | - | Standard |
| 25 | | | 0,1667 | 1 | 42 | 3,9 | - | - | - | |
| 40 | 158 | 5 | | | 52 | 3,9 | - | - | - | Standard |
| 40 | | | 0,2 | 1 | 52 | 3,9 | - | - | - | |
| 60 | 170 | 2,5 | | | 13 | 3,9 | - | - | - | Standard |
| 60 | | | 0,4 | 1 | 13 | 3,9 | - | - | - | |
| 100 | 180 | 1,5 | | | 23 | 3,9 | - | - | - | Standard |
| 100 | | | 0,6667 | 1 | 23 | 3,9 | - | - | - | |

Table 13. Configuration variants for meter factor (DD) and pulse duration (E) with fixed divider 1 for MULTICAL®. These variants can only be configured via METERTOOL HCW. Note that flow sensors with q_p 0.6 are not created for ULTRAFLOW® 44.

4.3.5 Accessories for Pulse Transmitter and Pulse Divider

Note that not all article numbers in *Table 14* can be directly ordered, some must be ordered via our service department (please send an email to service@kamstrup.com).

| Article number | Description | Note (when ordering Pulse Transmitter/Pulse Divider) |
|-------------------------------|--|---|
| 65-000-000-2000 | D-cell lithium battery with two-pole connector | |
| 3026-477 ¹⁾ | Fitting for D-cell battery | Enclosed if battery supply or "No supply" is selected |
| 1650-157 ¹⁾ | Plug for cable connection | Enclosed if battery supply or "No supply" is selected |
| 65-000-000-7000 ²⁾ | 230 VAC supply module | |
| 65-000-000-8000 ²⁾ | 24 VAC supply module | |
| 5000-290 | Cable between supply module and output module | Enclosed if supply module is selected |
| 5000-286 | 24/230 VAC power cable | Optional |
| 6699-012 | Output module (Y=2), galvanically separated 5550-1062 | |
| 6699-013 | Output module (Y=3), galvanically separated, "Low power" 5550-1219 | |
| 5000-333 | 2.5 m silicone cable (3-wire) | Optional |
| 5000-259 | 5 m silicone cable (3-wire) | Optional |
| 5000-270 | 10 m silicone cable (3-wire) | Optional |
| 3026-207.A | Wall bracket including mounting kit Can also be applied for MULTICAL® 603 | Optional |

¹⁾ Obligatory when changing from mains supply module to battery supply.

²⁾ Including 5000-290.

Table 14. Accessories for Pulse Transmitter and Pulse Divider

4.3.6 Cables

Pulse Transmitter and Pulse Divider are available with signal cable lengths 2.5 m, 5 m or 10 m. The signal cable is mounted from the factory.

If 24/230 VAC supply module is selected, Pulse Transmitter and Pulse Divider are optionally available with mains supply cable. The cable is mounted from the factory.

4.3.7 Cable Extender Box

Cable Extender Box (Type 6699-036) enables a signal cable length of up to 30 m between ULTRAFLOW® and MULTICAL®. The equipment supports flow-info, but not galvanic separation (for more information, see paragraph 4.3.1). Cable Extender Box (Type 6699-036) must be ordered separately.

Kamstrup offers signal cables in lengths of 2.5 m (Type 5000-333), 5 m (Type 5000-259) and 10 m (Type 5000-270), which can be ordered separately. In combination with the signal cables, which are typically delivered with ULTRAFLOW®, different total lengths of up to 20 m between ULTRAFLOW® and MULTICAL® can be realized. With signal cables of varying lengths but of the same quality as Kamstrup's signal cables, it is possible to find individual solutions for cable extension of up to 30 m between ULTRAFLOW® and MULTICAL®. For electrical connections, see paragraph 6.12.5.

5 Dimension sketches

All flow sensors ULTRAFLOW® 44 include a separated electronics box, which contains the PCB. This electronics box is connected to the plastic casing on the respective meter housings with a coaxial cable with a length of $l < 1.2$ m. The plastic casing on the meter housings contains the transducers of the flow sensor. There exists two types of plastic casings on the meter housings. One type can be found on threaded meter housings with G $\frac{3}{4}$ B and G1B (see *Figure 2*), another type can be found on all other meter housings.

All measurements are in mm, unless otherwise stated.

5.1 Electronics box containing the PCB of ULTRAFLOW® 44

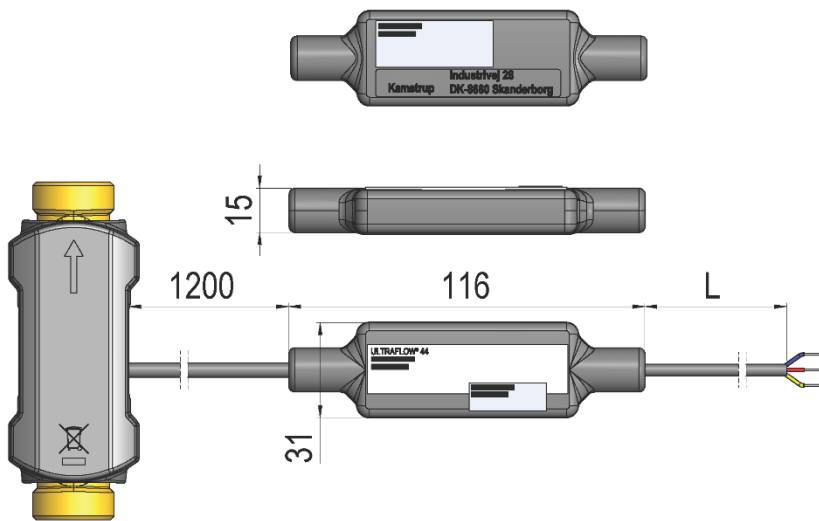

Figure 1. Dimension sketches of ULTRAFLOW® 44 electronics box containing the PCB together with the co-axial and signal cable.

| Nom. flow | L [m] | Approx. weight [kg] |
|-------------------------------------|----------|------------------------|
| q_p 1.5 and 2.5 m ³ /h | 2.5 | 0.18 |
| q_p 1.5...100 m ³ /h | 10 | 0.36 |

Table 15. Weight of ULTRAFLOW® 44 electronics box containing the PCB together with the co-axial and signal cable.

5.2 Threaded meters

5.2.1 ULTRAFLOW® 44 (Type 65-4-XXHX-XXX) – G¾B and G1B

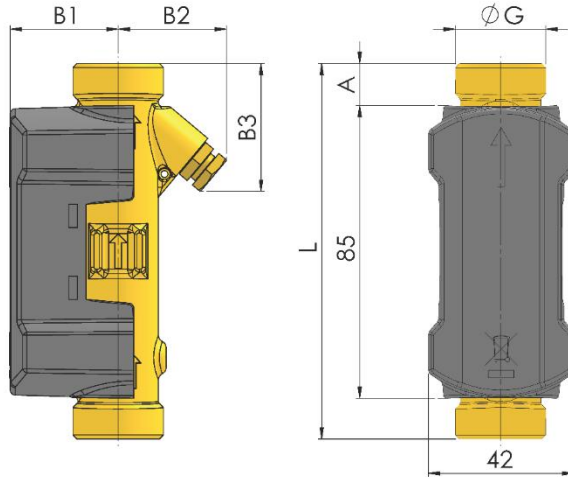

Figure 2. Dimension sketches of ULTRAFLOW® 44 threaded meters type 65-4-XXHX-XXX.

Thread EN ISO 228-1

| Thread | L | A | B1 | B2 | B3 | Approx. weight [kg] |
|--------------------------|-----|----|----|----|----|---------------------|
| G¾B (q _p 1.5) | 110 | 12 | 35 | 32 | 38 | 0.6 |
| G1B (q _p 1.5) | 130 | 22 | 38 | 32 | 48 | 0.7 |
| G1B (q _p 2.5) | 190 | 52 | 38 | 38 | 78 | 0.9 |

Table 16. Dimensions and weight of ULTRAFLOW® 44 threaded meters type 65-4-XXHX-XXX inclusive the electronics box with 2.5 m signal cable.

ULTRAFLOW® 44 DN15-125

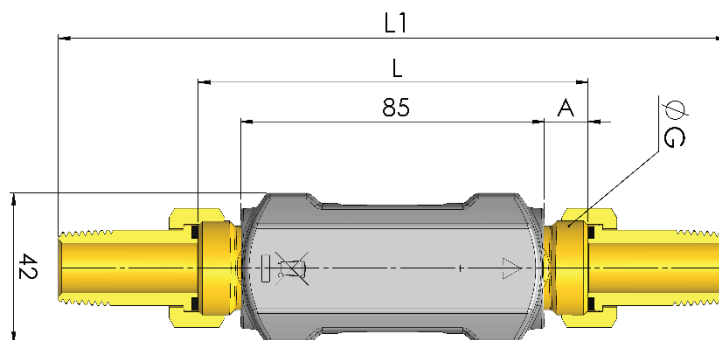

Figure 3. Dimension sketches of ULTRAFLOW® 44 threaded meters type 65-4-XXHX-XXX with couplings.

| Connection Flow sensor / Installation (ISO 228-1 / EN 10226-1) | Nominal Diameter | Length L | Length L1 | Weight of couplings 2 pcs. |
|--|---------------------|-------------|-------------------|----------------------------------|
| Thread | DN | [mm] | [mm] | [kg] |
| G¾B / R½ (q _p 1.5) | 15 | 110 | 189 | 0.2 |
| G1B / R¾ (q _p 1.5) | 20 | 130 | 228 | 0.3 |
| G1B / R¾ (q _p 1.5) | 20 | 165 | 262 ^{*)} | 0.3 |
| G1B / R¾ (q _p 2.5) | 20 | 190 | 288 | 0.3 |

^{*)} G1B x 130 mm with couplings including adapter 1330-023 and extra gasket.

Table 17. Length of ULTRAFLOW® 44 threaded meters type 65-4-XXHX-XXX with and without couplings and weight of couplings.

5.2.2 ULTRAFLOW® 44 (Type 65-4-XXJX-XXX) – G5/4B, G1½B and G2B

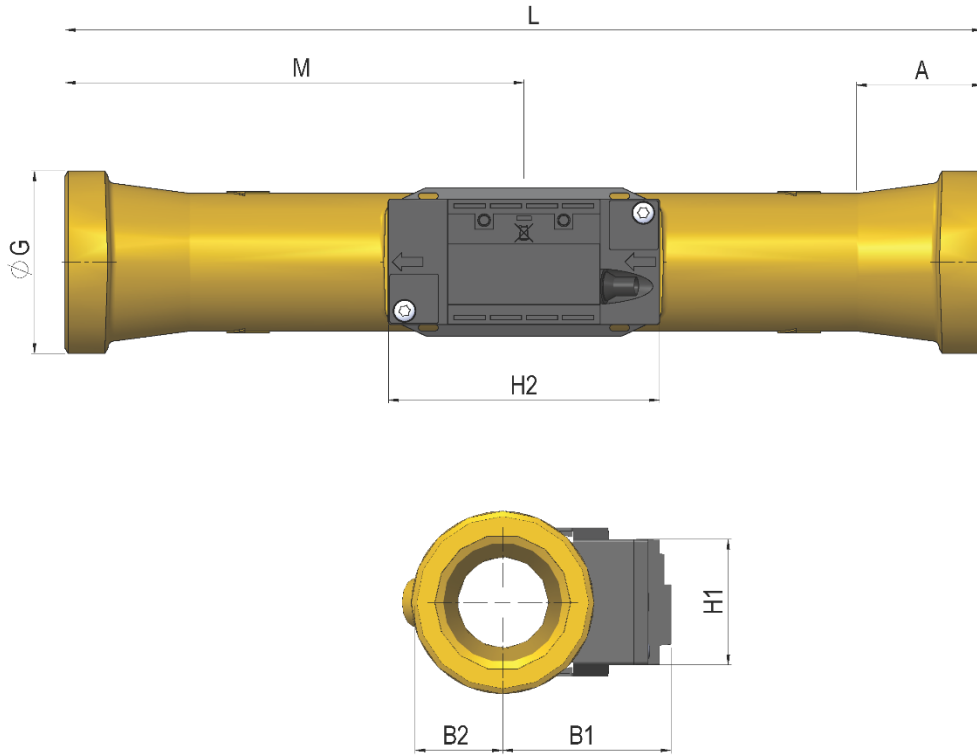

Figure 4. Dimension sketches of ULTRAFLOW® 44 threaded meters type 65-4-XXJX-XXX.

Thread EN ISO 228-1

| Thread | L | M | H2 | A | B1 | B2 | H1 | Approx. weight [kg] |
|---------------------------|-----|-----|----|------|----|----|----|---------------------|
| G5/4 (q _p 3.5) | 260 | L/2 | 88 | 16 | 51 | 20 | 41 | 1.9 |
| G5/4 (q _p 6.0) | 260 | L/2 | 88 | 16 | 53 | 20 | 41 | 2.0 |
| G1½ (q _p 6.0) | 260 | L/2 | 88 | 31 | 60 | 24 | 41 | 2.0 |
| G2 (q _p 10) | 300 | L/2 | 88 | 40.2 | 55 | 29 | 41 | 2.9 |

Table 18. Dimensions and weight of ULTRAFLOW® 44 threaded meters type 65-4-XXJX-XXX inclusive the electronics box with 10 m signal cable.

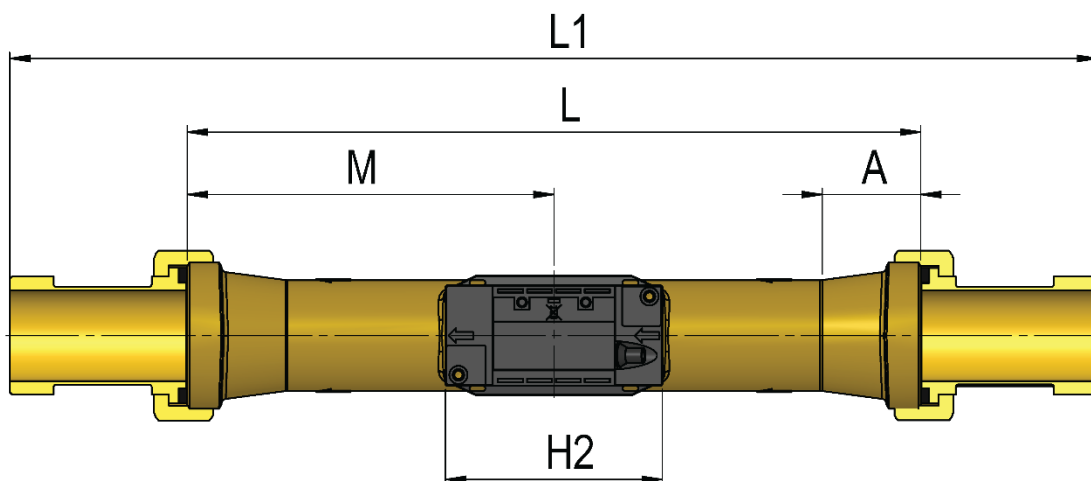

Figure 5. Dimension sketches of ULTRAFLOW® 44 threaded meters type 65-4-XXIX-XXX with and without couplings.

| Connection Flow sensor / Installation (ISO 228-1 / EN 10226-1) | Nominal Diameter | Length L | Length L1 | Weight of couplings 2 pcs. |
|--|---------------------|-------------|--------------|----------------------------------|
| Thread | DN | [mm] | [mm] | [kg] |
| G5/4B / R1 (q _p 3.5; 6.0) | 25 | 260 | 378 | 0.6 |
| G1½B / R5/4 (q _p 6.0) | 32 | 260 | 376 | 0.8 |
| G2B / R1½ (q _p 10) | 40 | 300 | 428 | 1.0 |

Table 19. Length of ULTRAFLOW® 44 threaded meters type 65-4-XXIX-XXX with and without couplings and weight of couplings.

5.3 Flange meters

5.3.1 ULTRAFLOW® 44 – DN25, DN40 and DN50

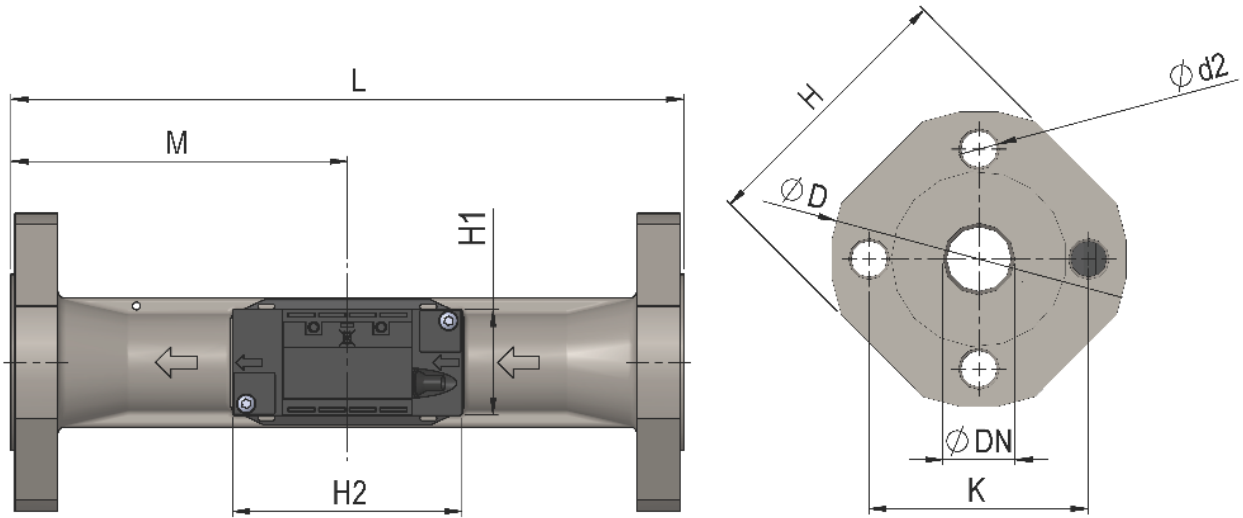

Figure 6. Dimension sketches of ULTRAFLOW® 44 flange meters DN25, DN40 and DN50.

“Flange facing type B, raised face” in accordance with EN 1092-1, PN25

| Nom. diameter | L | M | H2 | D | H | k | H1 | Bolts | | | Approx. weight [kg] |
|---------------------------|-----|-----|----|-----|-----|-----|----|--------|--------|----------------|------------------------|
| | | | | | | | | Number | Thread | d ₂ | |
| DN25 (q _p 6.0) | 260 | L/2 | 88 | 115 | 106 | 85 | 41 | 4 | M12 | 14 | 4.5 |
| DN40 (q _p 10) | 300 | L/2 | 88 | 150 | 140 | 110 | 41 | 4 | M16 | 18 | 7.4 |
| DN50 (q _p 15) | 270 | 155 | 88 | 165 | 145 | 125 | 41 | 4 | M16 | 18 | 8.5 |

Table 20. Dimensions and weight of ULTRAFLOW® 44 flange meters DN25, DN40 and DN50 inclusive the electronics box with 10 m signal cable.

ULTRAFLOW® 44 DN15-125

5.3.2 ULTRAFLOW® 44 – DN65 to DN125

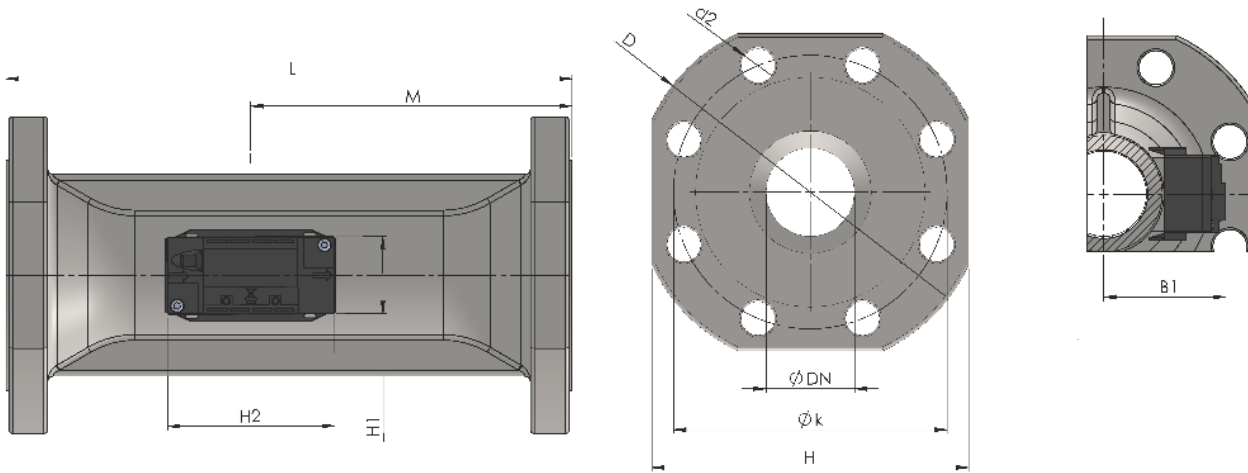

Figure 7. Dimension sketches of ULTRAFLOW® 44 flange meters DN65 to DN125.

“Flange facing type B, raised face” in accordance with EN 1092-1, PN25

| Nom. diameter | L | M | H1 | H2 | B1 | D | H | k | Bolts | | | Approx. weight [kg] |
|-----------------------------------|-----|-----|----|----|------|-----|-----|-----|--------|--------|----------------|------------------------|
| | | | | | | | | | Number | Thread | d ₂ | |
| DN65 (q _p 25) | 300 | 170 | 41 | 88 | <H/2 | 185 | 168 | 145 | 8 | M16 | 18 | 13.5 |
| DN80 (q _p 40) | 300 | 170 | 41 | 88 | <H/2 | 200 | 184 | 160 | 8 | M16 | 18 | 17.1 |
| DN100 (q _p 60 and 100) | 360 | 210 | 41 | 88 | <H/2 | 235 | 220 | 190 | 8 | M20 | 22 | 22.0 |
| DN125 (q _p 100) | 350 | 212 | 41 | 88 | <H/2 | 270 | 260 | 220 | 8 | M24 | 26 | 28.5 |

Table 21. Dimension and weight of ULTRAFLOW® 44 flange meters DN65 to DN125 inclusive the electronics box with 10 m signal cable.

5.4 Pulse Transmitter and Pulse Divider

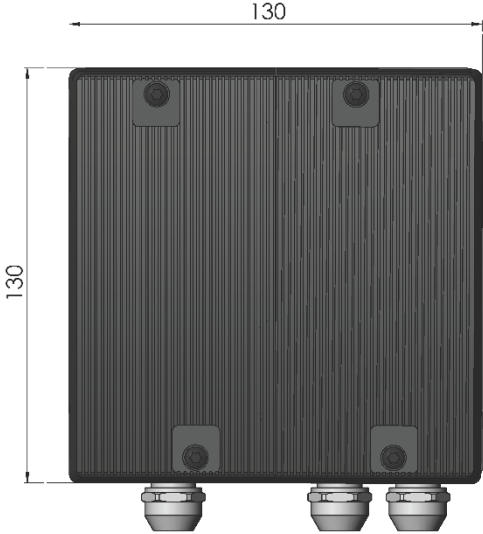

Figure 8. Pulse Transmitter/Pulse Divider seen from the front.

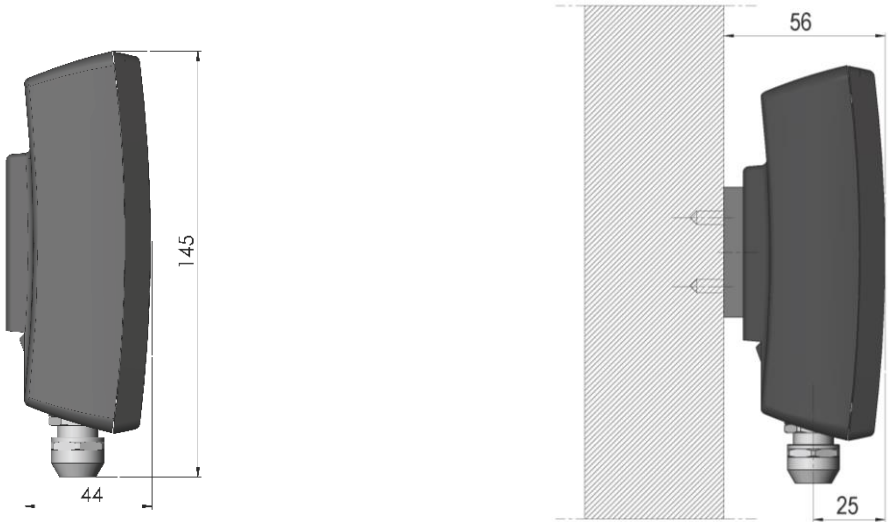

Figure 9. Pulse Transmitter/Pulse Divider seen from the side.

Figure 10. Wall-mounted Pulse Transmitter/Pulse Divider

5.5 Cable Extender Box

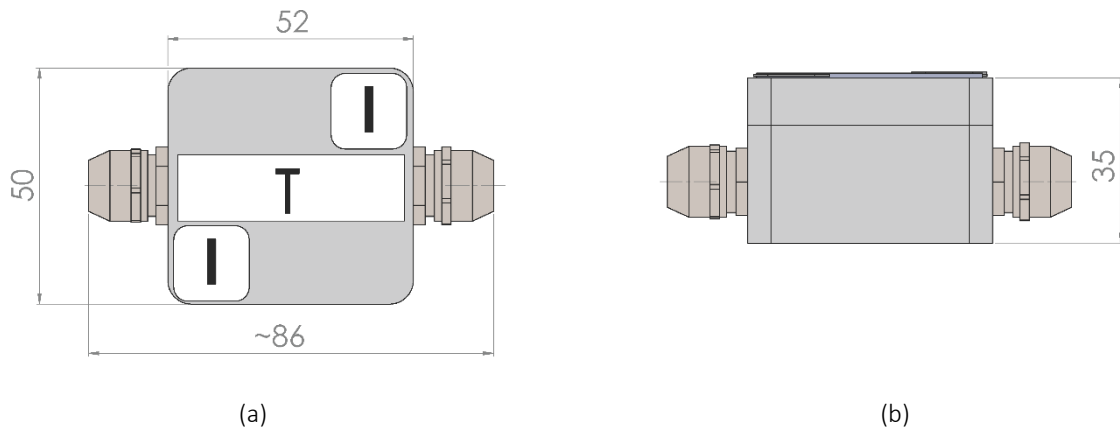

Figure 11. Cable Extender Box seen from the front (a) and from the side (b).

6 Installation



Please read this chapter carefully before installing the energy meter. In case of incorrect mounting, Kamstrup's guarantee obligations no longer apply.

6.1 Guidelines for dimensioning and operating conditions

6.1.1 Introduction

General recommendations for heat and cooling meter installation can be found in EN 1434-6:2015, "Heat meters – Part 6: Installation, commissioning operational monitoring and maintenance" and CEN TR 13582, "Heat meter installation. Instruction in selection, installation and use of heat meters". Due to copyrights, Kamstrup cannot provide you directly with these documents. To acquire CEN TR 13582 (and other EN standards), please refer, for example, to the Danish Standard organization's web shop <https://webshop.ds.dk/en-gb/frontpage?CurrencyCode=EUR>. Alternatively, you can find your national standardization organization here <https://www.iso.org/members.html>.

Consider the following general risks and advice:



By connecting to 230 VAC supply, there is a risk of electrical shock.



When working on the flow sensor in the installation, there is a risk of outflow of (hot) water under pressure.



At a media temperature higher than 60 °C, the flow sensor should be shielded from unintended contact.



New fibre gaskets in original quality must be used for flanged meters.



Only use clean water on a damp cloth to clean the meter.



Prior to installation of the flow sensor, the system should be flushed.



Correct flow sensor position (inlet or outlet) appears from the front label or the display of MULTICAL®. The flow direction is indicated by an arrow on the flow sensor. See e.g. *Figure 14* and *Figure 61*.



Check that the self-adhesive protective film on both ends of the flow sensor is removed before installation. When the installation has been completed, water flow can be turned on. The valve on the meter's inlet side must be opened first.



Carry out an operational check of the complete thermal energy meter after installing the meter and before leaving the installation site.

ULTRAFLOW® 44 DN15-125

6.1.2 Dimensioning

Consider among others, the following aspects, when dimensioning the meter:

Pipe dimension: Note, that the flow sensor size shall fit to the pipe dimension of the installation. However, one dimension up or down in flow sensor size is acceptable. This means that for a pipe dimension of e.g. DN20 in the installation corresponding to G1B (R¾) threads, a flow sensor size of DN 20 is optimum, but DN15 and DN25 are also acceptable. See also Kamstrup doc. nr. 5811-6554_GB.

Flow: The maximum flow in the system must NOT exceed the nominal flow q_p of the flow sensor. For further explanation see 6.1.4 *Operating pressure*.

Static pressure: The static pressure at the flow sensor outlet must at all times be above the minimum requirement and in general below the maximum allowable pressure. For further details see 6.1.4 *Operating pressure*.

Meter factor: The meter factor of ULTRAFLOW® and MULTICAL® must be identical (see type label/display). For further details about available meter factors of ULTRAFLOW®, see *Table 1*.

6.1.3 Operating conditions

The meter must be suitable for the foreseeable operating conditions in the installation:

Pressure stage: PN16/PN25, see marking. The marking of the flow sensor also covers accessories included such as couplings and gaskets as well as the blind plug.

Medium temperature ¹⁾: 2...130 °C or narrower range, see marking.

¹⁾ At medium temperature higher than 60 °C the flow sensor should be shielded against unintentional contact. At medium temperatures above 90 °C or below ambient temperature, calculator and Pulse Transmitter/Pulse Divider must not be mounted on the flow sensor. Instead wall-mounting is recommended. See *Table 14 Accessories for Pulse Transmitter and Pulse Divider*.

Mechanical environment: **MID M1** – applies to instruments used in locations with vibration and shocks of low significance, e.g. for instruments fastened to light supporting structures subject to negligible vibrations and shocks transmitted from local blasting or pile-driving activities, slamming doors, etc.– **and M2** – applies to instruments used in locations with significant or high levels of vibration and shock, e.g. transmitted from machines and passing vehicles in the vicinity or adjacent to heavy machines, conveyor belts, etc.

Electromagnetic environment: **MID E1** – applies to instruments used in locations with electromagnetic disturbances corresponding to those likely to be found in residential, commercial and light industrial buildings. – **and E2** – applies to instruments used in locations with electromagnetic disturbances corresponding to those likely to be found in other industrial buildings. **EN 1434 class C** (high electrical and electromagnetic conditions).
⚠ The meter's signal cables must be drawn at min. 25 cm distance from other installations.

Ambient conditions: The ambient temperature must be within 5...55 °C. Installation must be in closed locations (indoors).

Static pressure ²⁾: To minimise the risk of measuring errors as a result of cavitation or air in the water it is recommended to keep a sufficient static pressure at the flow sensor outlet of min. 1.5 bar (1.0 bar for ULTRAFLOW® 44 type 65-4-XXHX-XXX) up to q_p and min. 2.5 bar (2.0 bar for ULTRAFLOW® 44 type 65-4-XXHX-XXX) at q_s . This applies to temperatures

up to approx. 80 °C. It is particularly recommended to follow this advice during meter calibration. In absence of cavitation, the flow sensor is typically functioning at lower operating pressure. See also 6.1.4 *Operating pressure*.

💡 ²⁾ ULTRAFLOW® must not be exposed to lower pressure than the ambient pressure (vacuum). This minimises the risk of transducer damage.

Pressure loss: Consider the pressure loss of the installed flow sensor for dimensioning of pumps in your installation. For further details, see 6.1.5 *Pressure loss*.

| | | |
|--|----------------------------------|-------|
| Protection class ³⁾ / Climatic conditions: | Flow sensor: | IP 68 |
| ³⁾ acc. to EN 60529 | Pulse Transmitter/Pulse Divider: | IP67 |
| | Cable extender box: | IP65 |

³⁾ IP6X means that persons handling the instrument are protected against access to hazardous parts even when dealing with a thin wire of 1.0 mm diameter. In addition, the inside of the instrument is protected against ingress of dust (**dust-tight**).

³⁾ IPX5 means that that the instrument is **protected against water jets coming from any directions** to the enclosure.

For the Cable Extender Box this means that the IP class is higher than required by EN 1434 for other enclosures, which is not to be installed in pipe work. Note that it is the responsibility of the installer to ensure proper mounting of the cable screw connections as otherwise IP classification is not valid. The Cable Extender Box is not protected against periodically or permanently wet conditions and must not be submerged.

³⁾ IPX7 means that ingress of water in quantities causing harmful effects are not possible even when the enclosure of the instrument is **temporarily immersed** in water.

For the Pulse Transmitter/ Pulse Divider this means that it is well protected and durable in periodically wet conditions. It can tolerate to be submerged for max 30 min, but only in case of proper mounting of the cable screw connections. It is the responsibility of the installer to ensure proper mounting of the cable screw connections as otherwise IP classification is not valid (see 6.12.4.4 *Cable screw connections*).

³⁾ IPX8 means that ingress of water in quantities causing harmful effects are not possible even when the enclosure of the instrument is **continuously immersed** in water **as specified by the manufacturer**.

For the flow sensor ULTRAFLOW® 44 this means that it is well protected and durable in permanently wet conditions. It can even be submerged for 2 months. Note that the connected calculator must not be submerged.

💡 When installing a thermal energy meter, the installation recommendations of all three sub-assemblies, i.e. flow sensor, temperature sensor set and calculator, need to be considered. This applies in particular when a temperature sensor is directly mounted in the flow sensor and when a calculator is mounted directly on a flow sensor.

6.1.4 Operating pressure

To minimise the risk of measuring errors as a result of cavitation or air in the water it is recommended to keep a sufficient static pressure at the flow sensor outlet of min. 1.5 bar (1.0 bar for ULTRAFLOW® 44 type 65-4-XXHX-XXX) up to q_p and min. 2.5 bar (2.0 bar for ULTRAFLOW® 44 type 65-4-XXHX-XXX) at q_s . This applies to temperatures up to approx. 80 °C. It is particularly recommended to follow this advice during meter calibration. In absence of cavitation, the flow sensor is typically functioning at lower operating pressure. Furthermore, ULTRAFLOW® must not be exposed to lower pressure than the ambient pressure (vacuum). This minimises the risk of transducer damage.

It is not necessarily cavitation in the sensor itself, but also bubbles from cavitating pumps and regulating valves mounted before the sensor. It can take some time until such bubbles have been dissolved in the water. Furthermore, water can include air which is dissolved in the water. The amount of air which can be dissolved in water depends on pressure and temperature. This means that air bubbles can be formed due to a decrease in pressure, e.g. caused by a velocity rise in a pipe contraction or above the sensor. The risk of these factors affecting accuracy is reduced by maintaining a suitable pressure in the system.

In relation to the recommended static pressure, the steam pressure at the current temperature must also be considered. The recommended static pressure applies to temperatures up to approx. 80 °C.

The steam pressure is the pressure where steam and liquid are in equilibrium at the current temperature (boiling point at a given pressure). At low temperature and high pressure, water is in the liquid phase. At high temperature and low pressure, water is in the steam phase. The blue curve (the steam pressure curve) in *Figure 12* thus characterises the equilibrium of the liquid and steam phases. This means that the static pressure in water must be increased at a given temperature to avoid the steam phase that is shown in the lower right corner of the graph in *Figure 12*.

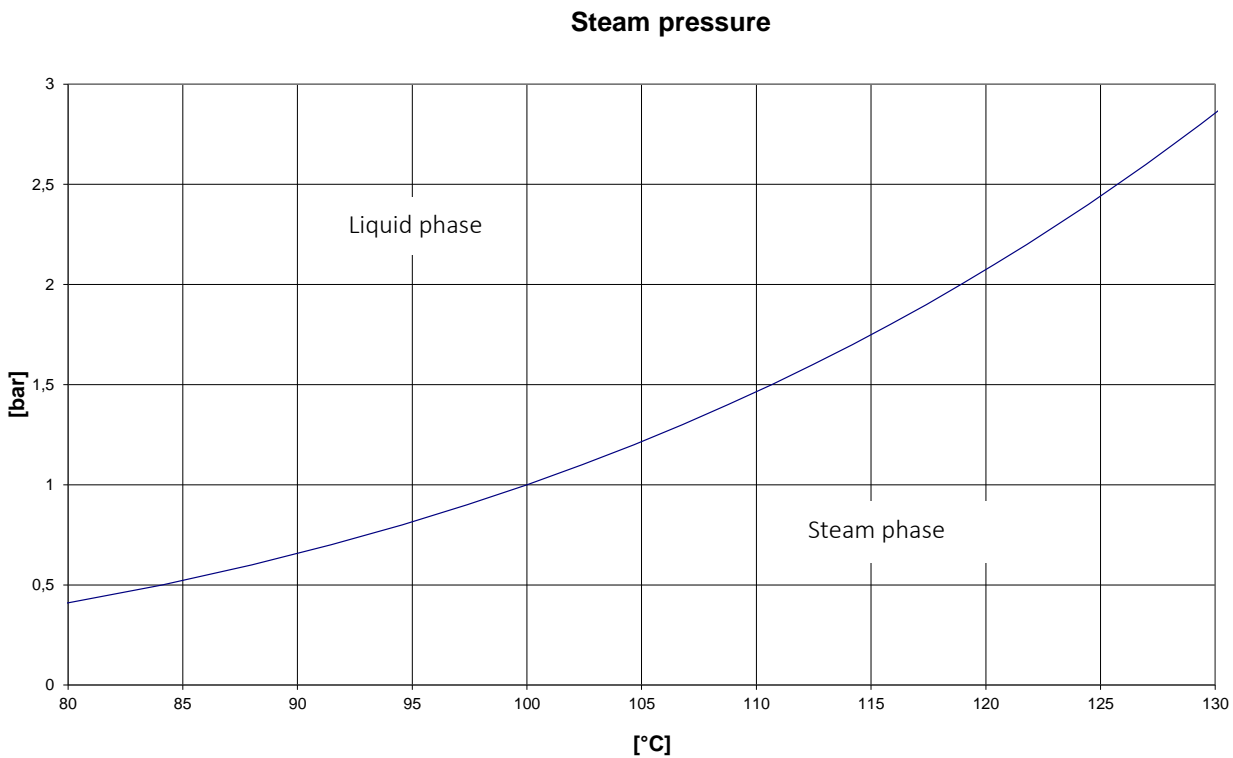

Figure 12. Steam pressure of water. At low temperature and high pressure, water is in the liquid phase. At high temperature and low pressure, water is in the steam phase. The blue curve characterises the equilibrium of the liquid and steam phases.

Furthermore, it must be taken into account that the static pressure is lower after a contraction than before (among other things cones). This means that the static pressure – when measured elsewhere in the installation – might be different from the pressure at the flow sensor outlet.

This can be explained by combining Bernoulli's equation and the continuity equation. Based on Bernoulli's equation, the total pressure of the flow will be the same for any cross section. It can be reduced to:

$$p_{stat.} + p_{dynam.} = p_{stat.} + \frac{1}{2}\rho v^2 = constant \quad (\text{Bernoulli's equation})$$

$p_{stat.}$ is the static pressure. $[Pa = \frac{N}{m^2} = \frac{kg}{s^2 \cdot m}]; 1 bar = 10^5 \frac{N}{m^2}$

$p_{dynam.}$ is the dynamic pressure. $[Pa = \frac{N}{m^2} = \frac{kg}{s^2 \cdot m}]; 1 bar = 10^5 \frac{N}{m^2}$

ρ is the water density. $[\frac{kg}{m^3}]$

v is the water flow rate. $[\frac{m}{s}]$

The continuity equation determines that the product of pipe cross sectional area A and average flow velocity v , which corresponds to the volume flow rate passing through, is constant for an incompressible fluid like e.g. water. Therefore, the flow velocity is increased in a contraction and the static pressure falls.

$$q = A_1 \cdot v_1 = A_2 \cdot v_2 = \dots = A_i \cdot v_i = constant \quad (\text{Continuity equation})$$

When dimensioning a flow sensor, you must take the above into consideration, especially if the sensor is used within the scope of EN 1434 between q_p and q_s , and in case of major pipe contractions. In general, we recommend to dimension the flow sensor's nominal flow q_p according to the expected maximum flow in the installation.

6.1.5 Pressure loss

Pressure loss in a flow sensor is stated as maximum pressure loss at q_p . According to EN 1434, max pressure loss must not exceed 0.25 bar, unless the energy meter includes a flow controller or functions as a pressure reducing equipment.

The pressure loss increases with the square of the flow and is usually stated as a direct proportionality between the flow and the square root of the pressure loss:

$$\Delta p = \frac{1}{k_v^2} q^2 \Leftrightarrow q = k_v \times \sqrt{\Delta p}$$

where:

$$q = \text{volume flow rate } [q] = \frac{m^3}{h}$$

$$k_v = \text{volume flow rate at 1 bar pressure loss } [k_v] = \frac{m^3}{h \cdot \sqrt{bar}}$$

$$\Delta p = \text{pressure loss } [\Delta p] = bar; 1 bar = 10^5 Pa$$

ULTRAFLOW® 44 DN15-125

| Graph | q _p [m³/h] | Nom. diameter [mm] | Δp@q _p [bar] | k _v | q@0.25 bar [m³/h] |
|-------|--------------------------|-----------------------|----------------------------|----------------|----------------------|
| A | 1.5 | DN15/DN20 | 0.09 | 4.9 | 2.4 |
| B | 2.5 | DN20 | 0.09 | 8.2 | 4.1 |
| C | 3.5 | DN25 | 0.07 | 13.4 | 6.8 |
| D | 6 | DN25/DN32 | 0.06 | 24.5 | 12.3 |
| E | 10 | DN40 | 0.06 | 40 | 20 |
| E | 15 | DN50 | 0.14 | 40 | 20 |
| F | 25 | DN65 | 0.06 | 102 | 51 |
| G | 40 | DN80 | 0.05 | 179 | 90 |
| H | 60 | DN100 | 0.03 | 373 | 187 |
| H | 100 | DN100/DN125 | 0.07 | 373 | 187 |

Table 22. Pressure loss table of ULTRAFLOW® 44.

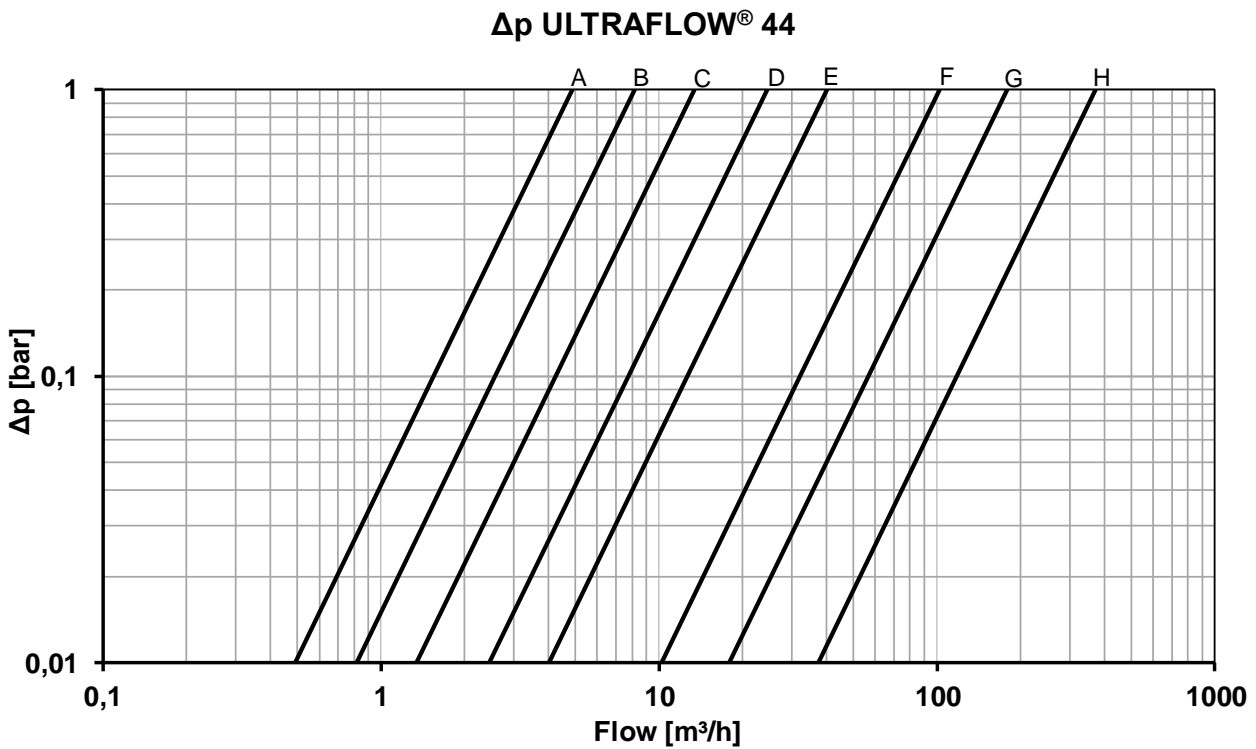

Figure 13. Pressure loss diagram of ULTRAFLOW® 44.

6.2 Connections, accessories, and assembly

Direct connection of ULTRAFLOW® is only permitted to Kamstrup MULTICAL® calculators on terminals 11-9-10, as shown in *6.12.1 Electrical connection of ULTRAFLOW® and MULTICAL®*. Connection to other calculator types requires the use of a Pulse Transmitter or Pulse Divider to obtain galvanic separation between ULTRAFLOW® and the calculator (*6.12.2 Electrical connection of Pulse Transmitter and Pulse Divider*).

💡 To achieve the easiest possible adjustment (e.g. during re-verification) we recommend to order ULTRAFLOW® 44 together with MULTICAL® 603 or MULTICAL® 803, whereby the flow sensor and the calculator will be delivered with identical serial number. Flow sensors ULTRAFLOW® 44, where the serial number of ULTRAFLOW® 44 and the connected MULTICAL® calculator is different from each other, can be considered as separately delivered. Adjustment of separately delivered ULTRAFLOW® 44 requires individual encryption keys.

For further information, please see paragraph *8.6 Adjustment of ULTRAFLOW® flow sensors with Kamstrup software*.

💡 Should you after careful consideration decide to order ULTRAFLOW® 44 separately, check that the meter factor is the same on the flow sensor and the calculator and use a Pulse Divider if this is not the case.

6.2.1 Couplings and mounting of temperature sensors

Correct flow sensor position (inlet or outlet) appears from the front label/display of MULTICAL®. When ULTRAFLOW® is connected to another calculator, ULTRAFLOW® can be used for both inlet and outlet. Crucial is the coding of the calculator. The flow direction of ULTRAFLOW® is indicated by arrows on the flow sensor. Couplings and gaskets for couplings as well as flange gaskets up to and including DN80 are suitable for both PN16 and PN25. Flange gaskets DN100 and DN125 are suitable for PN25 only due to their physical dimension. Couplings and gaskets are mounted as shown in Figure 14. See Table 6 and Table 7 for ordering details of suitable couplings and gaskets.

⚠ In connection with G1Bx110 mm, it must be checked that the thread run-out is sufficient.

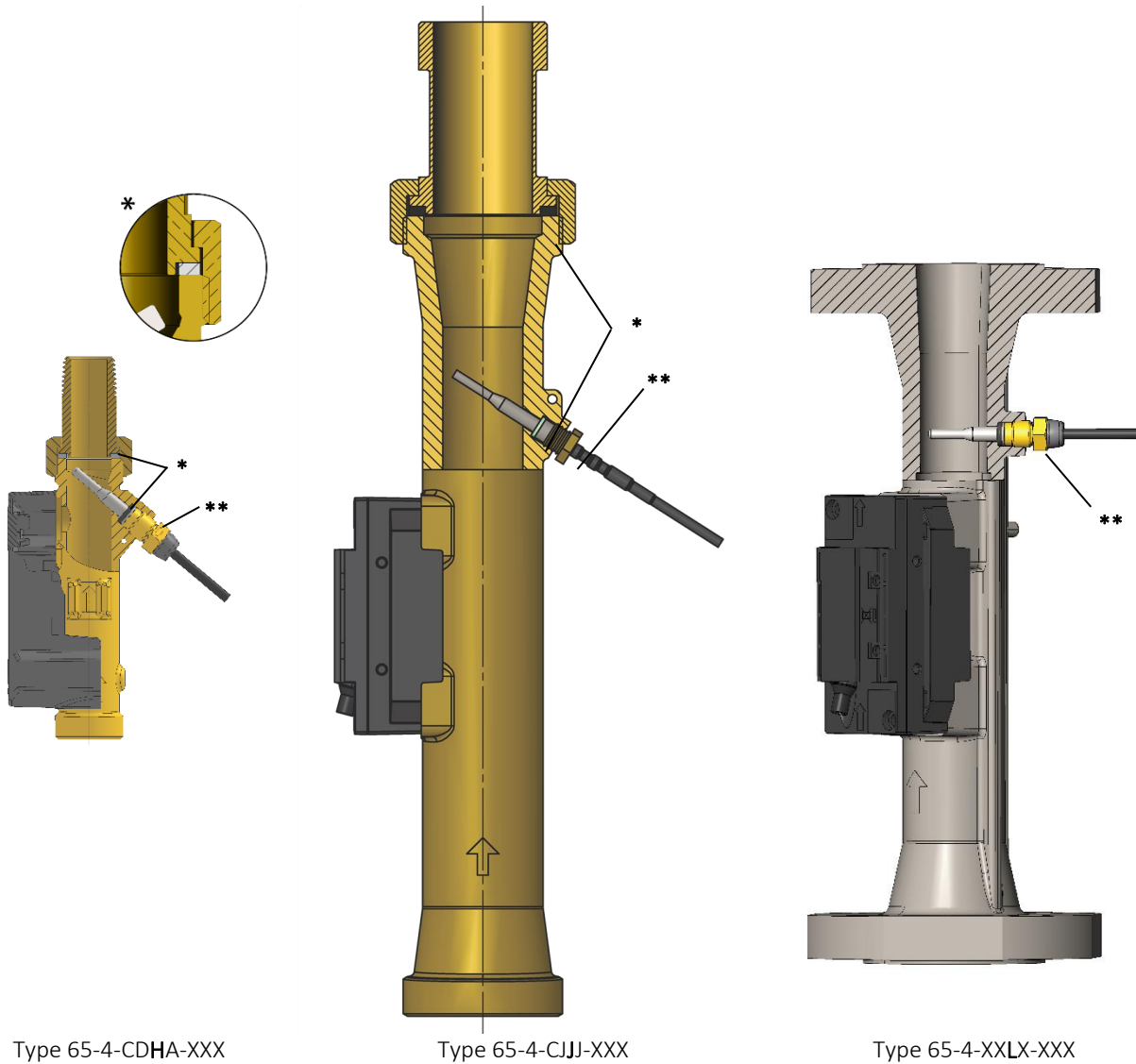

Figure 14. Examples of ULTRAFLOW® 44 flow sensors (with coupling) and TemperatureSensor 63 or direct short sensor DS38 mm (*Gaskets; **Torque value approx. 4 Nm).

Flow sensors ULTRAFLOW® 44 with q_p 1.5...10 m³/h allow the mounting of TemperatureSensor 63 (direct short or \varnothing 5.0 mm or \varnothing 5.2 mm) in the flow sensor (see Figure 14). TemperatureSensor 63 is suitable for both PN16 and PN25 installations. When exchanging with a separately verified set of TemperatureSensor 63, always use a new fibre gasket 2210-233 at sensor assembly. If the temperature sensor is not mounted in the flow sensor, a blind plug with O-ring, 3130-262, is used instead. The blind plug with O-ring is also suitable for both PN16 and PN25. TemperatureSensor 63 is approved for both heat and cooling. Direct short temperature sensors DS38 mm are approved for heat and technically suitable for cooling.

| Type number ¹⁾ | | | q _p [m ³ /h] | Connection | Length [mm] | Temperatur sensor M10 x 1 connection for TemperatureSensor 63 ²⁾ (DS 27.5, ø5.2, ø5.0) | Temperatur sensor M10 x 1 connection for DS 38 mm ³⁾ | Temperatur sensor M10 x 1 connection for DS 38 mm ³⁾ with adapter |
|---------------------------|-------|------|---------------------------------------|------------|----------------|--|---|--|
| 65-4- | CDHA- | -XXX | 1.5 | G¾B (R½) | 110 | Ok | Sensor too long | Ok |
| 65-4- | CDHD- | -XXX | 1.5 | G1B (R¾) | 130 | Ok | | Ok |
| 65-4- | CEHF- | -XXX | 2.5 | G1B (R¾) | 190 | Ok | | Ok |
| 65-4- | CGJG- | -XXX | 3.5 | G5/4B (R1) | 260 | Ok | | Ok |
| 65-4- | CHJG- | -XXX | 6 | G5/4B (R1) | 260 | Ok | | Ok |
| 65-4- | CHLB- | -XXX | 6 | DN25 | 260 | Ok | | Ok |
| 65-4- | CHJH- | -XXX | 6 | G1½B(R1¼) | 260 | Ok | | Ok |
| 65-4- | CJJJ- | -XXX | 10 | G2B (R1½) | 300 | Sensor too short | Ok | Sensor too short |
| 65-4- | CJLD- | -XXX | 10 | DN40 | 300 | | Ok | |
| 65-4- | CKCE- | -XXX | 15 | DN50 | 270 | No socket for mounting of temperature sensor available | | |
| 65-4- | CLCG- | -XXX | 25 | DN65 | 300 | | | |
| 65-4- | CMCH- | -XXX | 40 | DN80 | 300 | | | |
| 65-4- | FACL- | -XXX | 60 | DN100 | 360 | | | |
| 65-4- | FBCL- | -XXX | 100 | DN100 | 360 | | | |
| 65-4- | FBCM- | -XXX | 100 | DN125 | 350 | | | |

¹⁾ XXX - code for final assembly, approvals etc. - determined by Kamstrup. A few variants may not be available in national approvals.

²⁾ Approved for heat and cooling.



³⁾ Approved for heat and technical suitable for cooling.

Table 23. Direct mounting of a direct short temperature sensor in the outlet of the flow sensor ULTRAFLOW® 44.

6.2.2 Cable length of ULTRAFLOW® 44

ULTRAFLOW® 44 is always delivered with a fixed coaxial cable length of 1.2 m between the flow sensor housing and the electronics box (see Figure 1). The signal cable length (see Table 15) from the electronics box to the calculator is either 10 m or 2.5 m (qp 1.5 and 2.5 m³/h only). For a convenient installation the signal cable length can be shortened. In these cases, we recommend to crimp cable end sleeves. For a cable length of more than 10 m between ULTRAFLOW® and MULTICAL® see 4.3 Pulse Transmitter / Pulse Divider and Cable Extender Box.

6.3 Flow sensor position (Inlet/Outlet)

Correct flow sensor position (inlet or outlet) appears from the front label or display of MULTICAL®, where  indicates the position in inlet and  indicates the position in outlet. When ULTRAFLOW® is connected to another calculator, ULTRAFLOW® can be used for both inlet and outlet. Crucial is the coding of the calculator. The flow direction of ULTRAFLOW® is indicated by arrows on the flow sensor.

6.4 Insulation

Insulation of pipes utilized for transmitting thermal energy conveying liquids is in general always recommended, because the insulation reduces losses of valuable heat energy or avoids heating of the medium, which is utilized for cooling. Thus, insulation optimizes the supply of thermal energy with thermal energy conveying liquids. To further optimize the supply, insulation of flow and temperature sensors, which are both in direct contact with the thermal energy conveying liquid, must also be addressed. As the calculator of a heat/cooling meter is not in direct contact with the thermal energy conveying liquid, insulation of the calculator as such is not applicable. However, due to the possibility of mounting the calculator directly on the flow sensor, installation recommendations for the calculator must be considered depending on the temperature of the medium and the environment.

Insulation has the effect, that all parts under the insulation might reach temperatures up to the temperature of the thermal energy conveying liquid as thermal balance to the environment is prohibited. This might be critical to some components, in particular to sensitive electronics. Predominantly in cooling installations, humidity from the warm environment will condense on comparatively colder pipes. This is why they are often permanently wet. Insulation therefore requires temperature stability of the insulated parts within the approved range of the medium temperature as well as waterproof encapsulation of sensitive electronic components in cooling installations in warm and humid environments. Finally, note that local rules concerning insulation of pipes might apply.

Table 24 gives an overview about insulation recommendations for Kamstrup flow and temperature sensors. Figure 25 and Figure 26 illustrate specifically the insulation of ULTRAFLOW® 44 DN15-125.





| Flow sensor |  Cooling |  Heat $T_{\text{medium}} < 110\text{ °C}$  |  Heat $T_{\text{medium}} > 110\text{ °C}$  |
|-----------------------------------|---|---|--|
| MULTICAL® 303 | Yes | | Yes (except for the plastic case) |
| MULTICAL® 403 | | | |
| ULTRAFLOW® 44 DN15-125 | | | |
| ULTRAFLOW® 54 DN15-125 | N/A | Yes (except for the plastic case) | |
| ULTRAFLOW® 54 DN150-300 | Yes (except for the plastic case) | | |
| TemperatureSensor 63 & 83 | Yes | | |

Table 24: Overview of insulation recommendations for different flow sensors and for TemperatureSensor 63 & 83.

6.5 Inlet prerequisites

ULTRAFLOW® 44 requires neither straight inlet nor straight outlet to meet the Measuring Instruments Directive (MID) 2014/32/EU, OIML R75:2002 and EN 1434². A straight inlet section will only be necessary in case of heavy flow disturbances before the meter. It is recommended to follow the guidelines in *CEN TR 13582, Heat meter installation. Instructions in selection, installation and use of heat meters*. See also Kamstrup doc. no. 5811-6595_GB.

Optimal position can be obtained if you take the below installation recommendations into consideration.

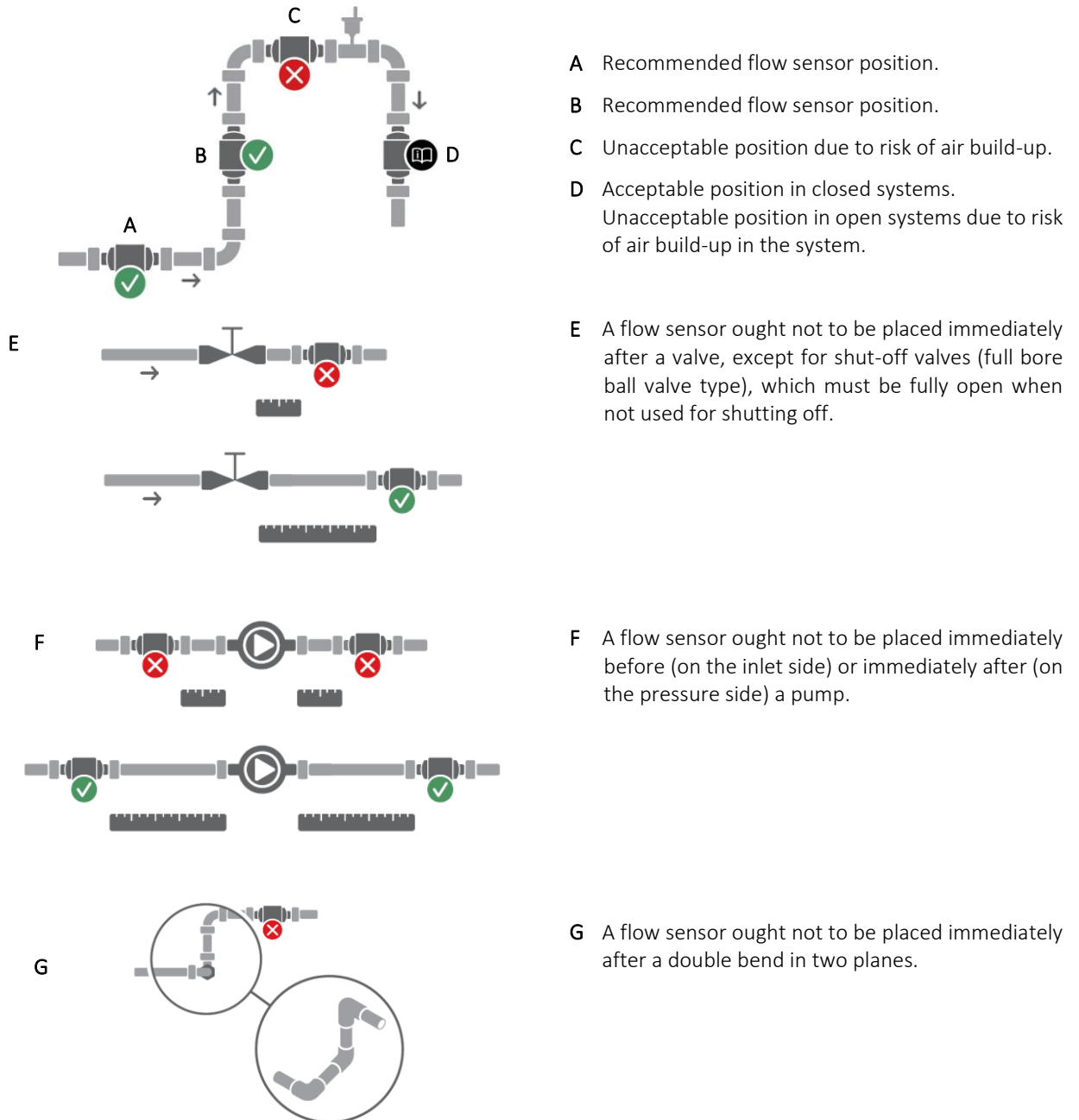

Figure 15. General installation recommendations for flow sensors.

² EN 1434:2007/AC:2007, EN 1434:2015+A1:2018 and EN 1434:2022

6.6 Orientation of Kamstrup’s flow sensors

The recommended orientation of the flow sensor in an installation takes into account the metrological sensitivity of the flow sensor to orientation, for example because of orientation-dependent flow profiles; poor water quality of district heating water, e.g. dirt, which can accumulate in the flow sensor; air in the system and finally because of environmental requirements, for example in case of condensation. The recommendations may vary for each of the types because of their diversity in the design.

6.6.1 General recommendations

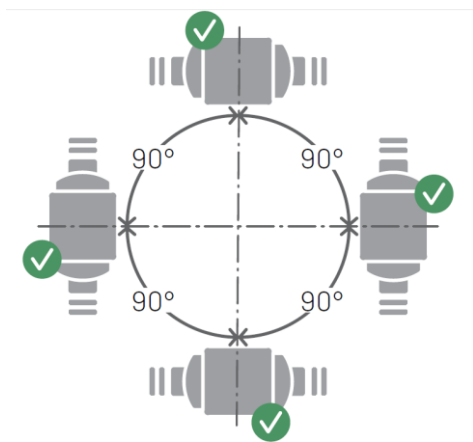

Kamstrup’s flow sensors can be mounted vertically, horizontally or at an angle.

If Kamstrup flow sensors are vertically mounted, they can be turned $\pm 360^\circ$ around the pipe axis.



The plastic box should be placed on the side (at horizontal mounting). See below for additional details.

Figure 16. Separate mounting of Kamstrup flow sensors. Vertically, horizontally or at an angle.

At horizontal mounting, Kamstrup’s flow sensors can be turned around the pipe axis. Acceptable angles of rotation for the various types of Kamstrup flow sensors can be found below.

At medium temperatures above 90 °C and below ambient temperature, i.e. for cooling installations, calculator and Pulse Transmitter/Pulse Divider must not be mounted on the flow sensor. Instead wall-mounting is recommended. The orientation of the flow sensor in a cooling installation does therefore not need to take the readability of the calculators display into account and can thereby be limited to the optimum orientation of the flow sensor only.

6.6.2 Recommendations for heat installations



Heat installations

Threaded meter housing with $q_p \leq 2.5 \text{ m}^3/\text{h}$

Threaded meter housing with $q_p \geq 3.5 \text{ m}^3/\text{h}$
and flange meters

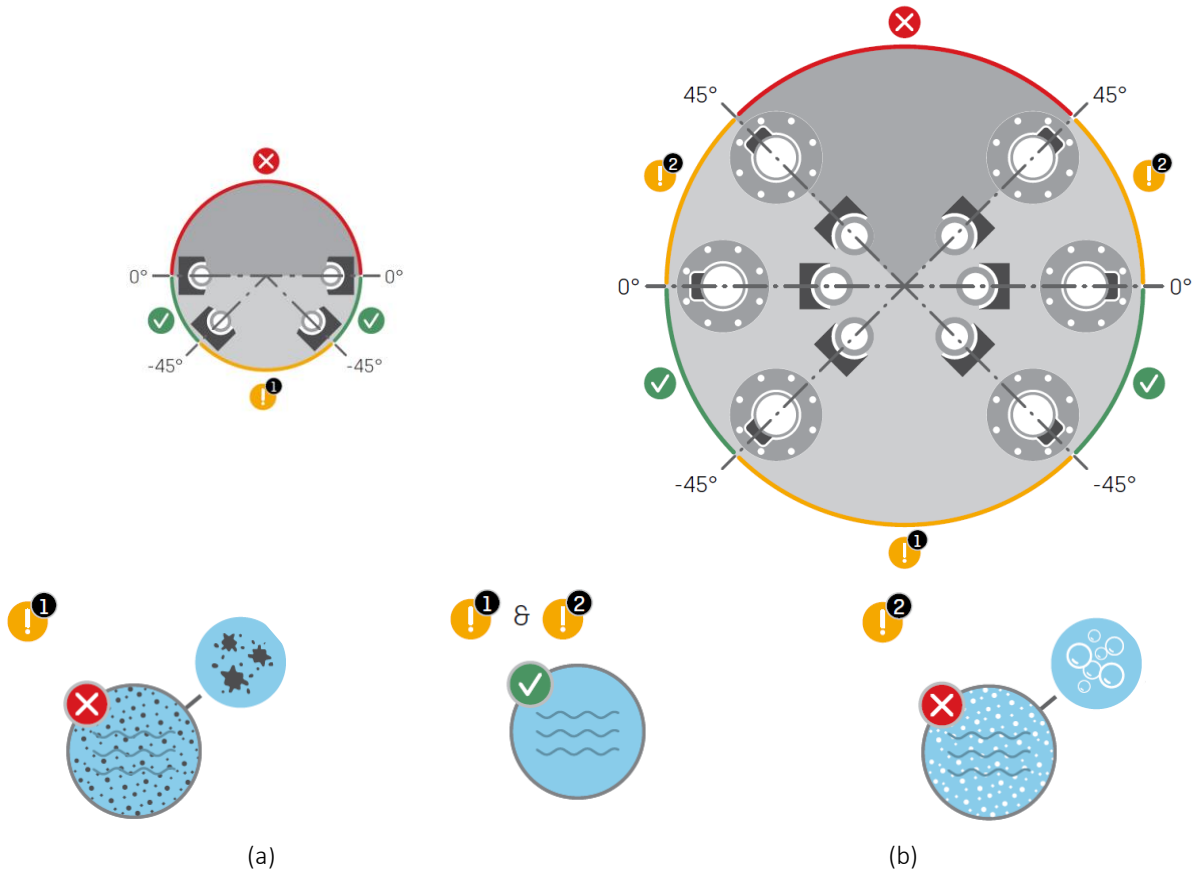

Figure 17. Acceptable orientation of Kamstrup flow sensors around the pipe axis for heating installations at horizontal mounting. (a) Threaded meter housings with $q_p \leq 2.5 \text{ m}^3/\text{h}$. (b) Threaded meter housings with $q_p \geq 3.5 \text{ m}^3/\text{h}$ and flange meters.

⚠ The orientations marked with “1” are conditionally accepted when the assumptions below are fulfilled.

- (1) District heating/cooling water must be clean and must not contain any kind of dirt. Dirt can otherwise be deposited on the transducers of the flow sensor, which affects their ability to detect and transmit the ultrasound signal.
- (2) District heating water must be free of air. Air bubbles will interfere severely with the ultrasound signal.

6.6.3 Recommendations for cooling and combined heat/cooling installations



Cooling and combined heat/cooling installations

Threaded meter housing with $q_p \leq 2.5 \text{ m}^3/\text{h}$

Threaded meter housing with $q_p \geq 3.5 \text{ m}^3/\text{h}$
and flange meters

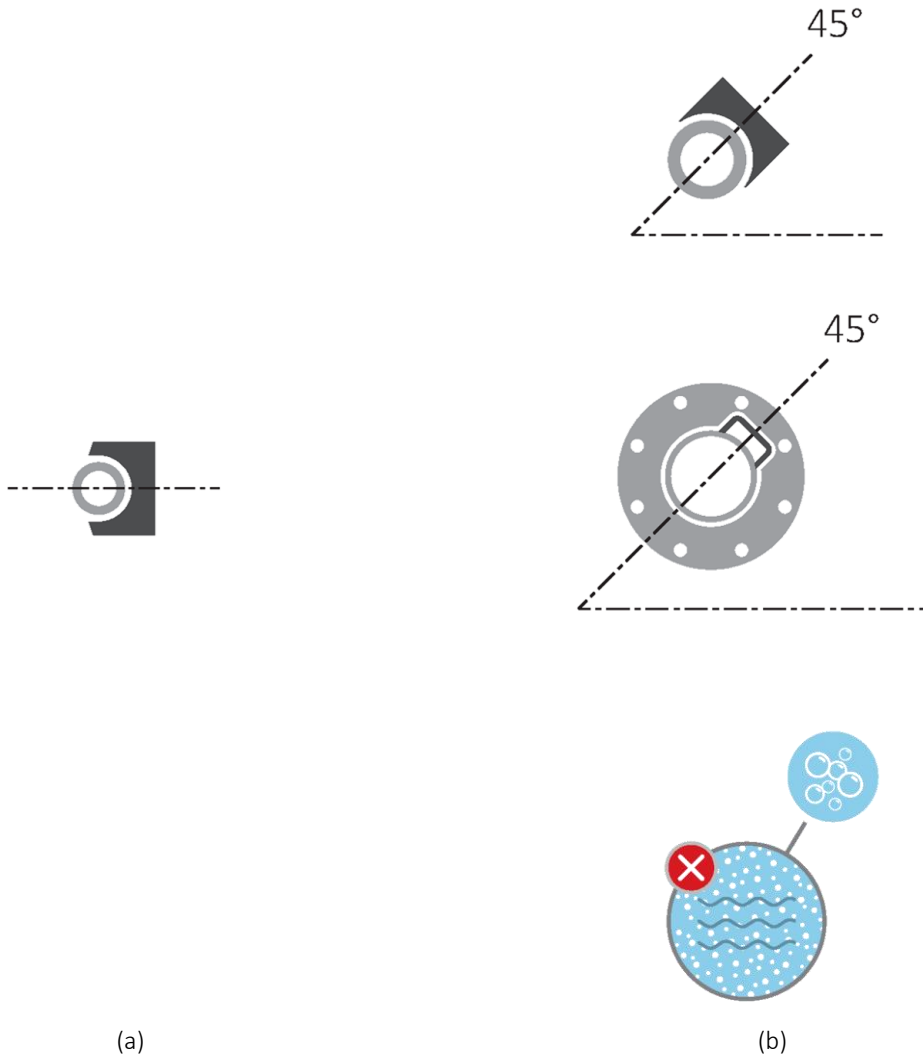

Figure 18. Recommended orientation of Kamstrup flow sensors around the pipe axis at horizontal mounting for cooling and combined heat/cooling installations. (a) Threaded meter housings with $q_p \leq 2.5 \text{ m}^3/\text{h}$. (b) Threaded meter housings with $q_p \geq 3.5 \text{ m}^3/\text{h}$ and flange meters.

⚠ District heating and cooling water must be free of air. Air bubbles will interfere severely with the ultrasound signal. If there is risk of air, mount all flow sensors like in position (a) with the transducers to the side.

6.6.4 Recommendations for directly mounted temperature sensors

When mounting a temperature sensor directly in the outlet of the flow sensor, acceptable orientations for the temperature sensor must be taken into account. For heating installations (*Figure 19 (a)*), the orientation of a temperature sensor is not important as long as a homogeneous temperature distribution can be assumed, i.e. all orientations can be accepted. For cooling installations (*Figure 19 (b)*), water penetration into the sensor element must be avoided. Therefore, a temperature sensor is mounted ideally from the bottom pointing with its tip upwards and can be rotated up to a horizontal position.



Figure 19. Acceptable orientation of a temperature sensor in (a) a heating and (b) a cooling installation.

These recommendations for temperature sensor installation comply with the recommendations for flow sensor installation illustrated in *Figure 17* and *Figure 18*. However, while a temperature sensor can well be directly installed in a flow sensor for cooling installation mounted in an ascending pipe, it must not be mounted in a flow sensor for cooling installation mounted in a descending pipe.

⚠ When ULTRAFLOW® 44 is utilized as a flow sensor for heating installations in environments with temporary submerge, a temperature sensor must NOT be mounted directly in the flow sensor.

6.7 Mounting of the electronics box of ULTRAFLOW® 44

The electronics box of ULTRAFLOW® 44 is lightweight (see *Table 15*) and can therefore hang freely as an integrated part of the cable between ULTRAFLOW® 44 and MULTICAL® (*Figure 20 (a)*). It contains the PCB of ULTRAFLOW® 44, which is on purpose NOT placed close to the flow sensor housing. Hereby the sensitive electronics is protected from condensation in cooling installations and thermal loads in heat installations because it is only exposed to environmental conditions. Therefore, it must NOT be mounted directly on the flow sensor housing or on pipes with thermal energy conveying media inside (*Figure 20 (b)*).

Although the PCB is completely moulded and therefore water proof (see paragraph *6.4 Insulation*) we recommend in humid environments, where water penetration into the meter electronics might occur over time, that wires/cables hang freely downwards after cable connections to form a drip nose for drainage of water and condensation. The electronics box of ULTRAFLOW® 44 should preferably be mounted horizontally and might be mounted with cable strips (*Figure 20 (c)*).

⚠ The electronics box of ULTRAFLOW® 44 must not be bent or clamped or be exposed to other impact forces. It contains sensitive electronics (PCB).

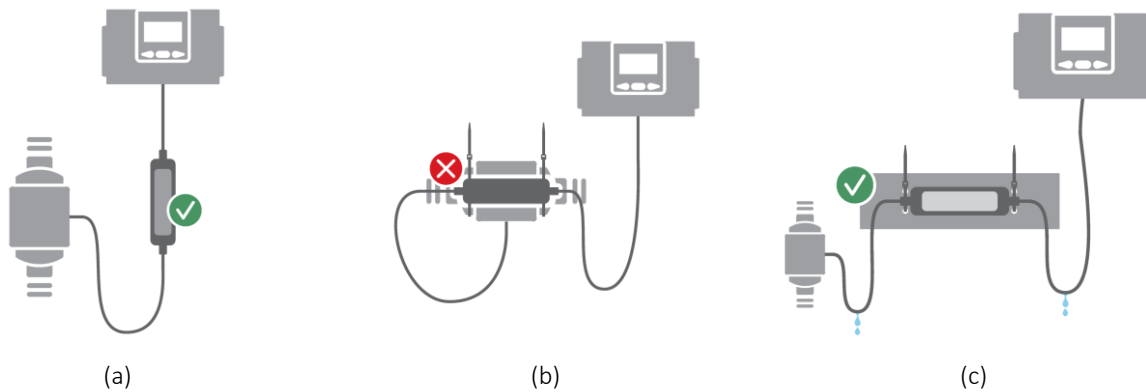

Figure 20. Mounting of the electronics box of ULTRAFLOW® 44: (a) Hanging freely, (b) must NOT be mounted on the flow sensor housing and (c) horizontally mounted with cable strips in humid environments.

6.8 Mounting of Pulse Transmitter and Pulse Divider

6.8.1 Orientation of Pulse Transmitter and Pulse Divider

Mounting Pulse Transmitter and Pulse Divider, the cable connections must always be horizontally or downwards oriented in order to avoid the risk of water and condensation being led into the electronics box via the cables. This is especially important in humid environments.

Furthermore, wires/cables must in general hang freely downwards after cable connections to form a drip nose for drainage of water and condensation.

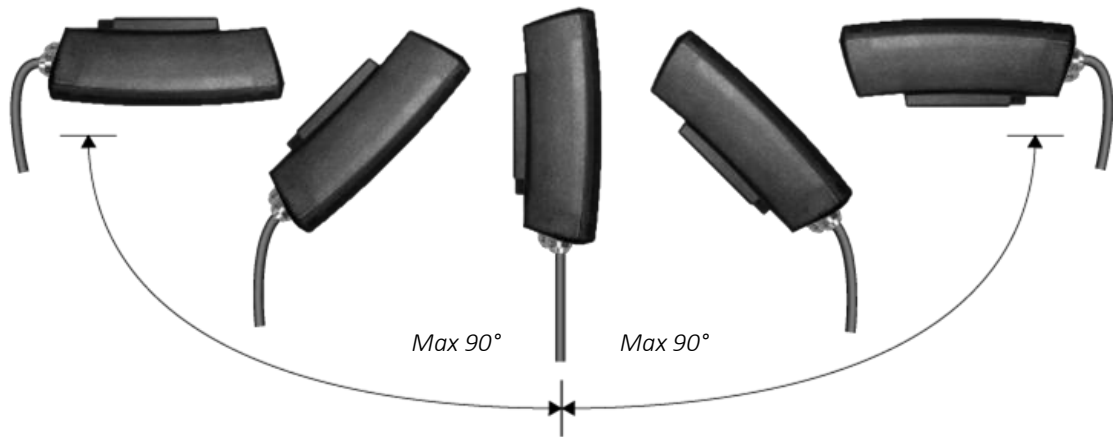

Figure 21. Orientation of Pulse Transmitter/Pulse Divider with respect to cable alignment.

6.8.2 Wall-mounting of Pulse Transmitter and Pulse Divider

⚠ At medium temperatures above 90 °C and below ambient temperature, calculator and Pulse Transmitter/Pulse Divider must not be mounted on the flow sensor. Instead wall-mounting is recommended.

Wall mounting of MULTICAL® and Pulse Transmitter/Pulse Divider protects these instruments against overheating in a heat installation and condensing water in a cooling installation.

ULTRAFLOW® 44 is by default not prepared for direct mounting of MULTICAL® or Pulse Transmitter/Pulse Divider. This is to protect MULTICAL® and Pulse Transmitter/Pulse Divider against condensation/submersion, which might occur in installations for ULTRAFLOW® 44.

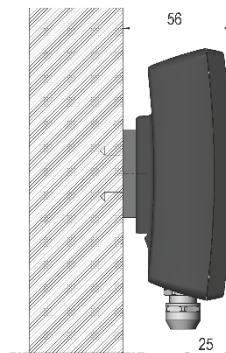

Figure 22. Pulse Transmitter/Pulse Divider mounted on fitting 3026-207.A

6.9 Mounting of Cable Extender Box

The Cable Extender Box is lightweight and can therefore hang freely as an integrated part of the signal cable from ULTRAFLOW® flow sensor to the calculator. Alternatively, the Cable Extender Box can be wall-mounted. The base part of the Cable Extender Box contains 2 holes for this purpose, which are prepared for mounting screws.

6.10 Maintenance and service during operation

The flow sensor is verified separately and can, therefore, be separated from the calculator. See the sealing drawings of the connected calculator such as MULTICAL® 603 (5512-2029_GB) or MULTICAL® 803 (5512-2360_GB).

Due to the sealing levels of Pulse Transmitter/Pulse Divider (see *Figure 62*), it is also permitted to replace the supply and exchange the supply type in Pulse Transmitter/Pulse Divider while ULTRAFLOW® is installed in the installation. For battery supply of Pulse Transmitter/Pulse Divider, a lithium battery with connector from Kamstrup A/S must be used. Lithium batteries must be correctly handled and disposed of (see chapter *12 Disposal*). It is permissible to replace output modules of Pulse Transmitter/Pulse Divider.

The cable length between ULTRAFLOW® and the MULTICAL® calculator may be extended under certain installation conditions, for example by use of Cable Extender Box, up to max 30 m (see *Figure 63*).

Other repairs of ULTRAFLOW® and Pulse transmitter/Pulse Divider requires subsequent re-verification in an accredited laboratory.

✨ To achieve the easiest possible adjustment (e.g. during re-verification) we recommend to order ULTRAFLOW® 44 together with MULTICAL® 603 or MULTICAL® 803, whereby the flow sensor and the calculator will be delivered with identical serial number. Flow sensors ULTRAFLOW® 44, where the serial number of ULTRAFLOW® 44 and the connected MULTICAL® calculator is different from each other, can be considered as separately delivered. Adjustment of separately delivered ULTRAFLOW® 44 requires individual encryption keys.

For further information, please see paragraph *8.6 Adjustment of ULTRAFLOW® flow sensors with Kamstrup software*.

6.11 Installation examples (mechanical)

ULTRAFLOW® 44 is by default not prepared for direct mounting of MULTICAL® or Pulse Transmitter/Pulse Divider on the flow sensor. This is to protect MULTICAL® and Pulse Transmitter/Pulse Divider for condense/submerge, which might occur in installations for ULTRAFLOW® 44.

⚠ At medium temperatures above 90 °C and below ambient temperature, calculator and Pulse Transmitter/Pulse Divider must not be mounted on the flow sensor. Instead wall-mounting is recommended.

6.11.1 ULTRAFLOW® 44 and MULTICAL® 603

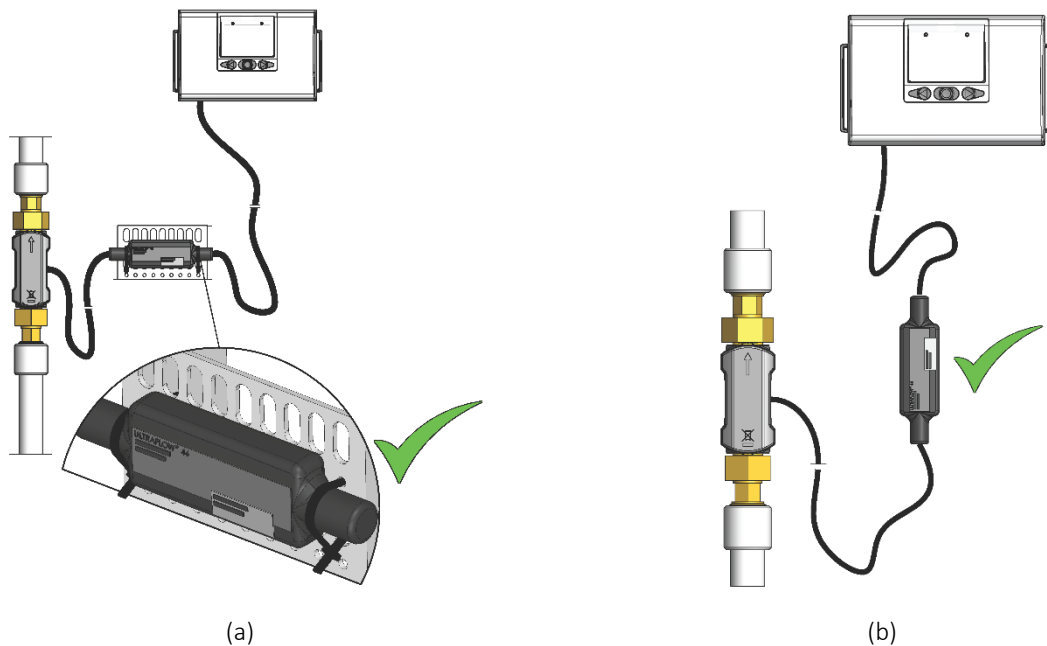

Figure 23. Installation of ULTRAFLOW® 44 in an ascending pipe. (a) The electronics box is mounted in humid environments horizontally with strips and the calculator is mounted above on the wall. Cables are hanging freely downwards after cable connections to form a drip nose for drainage of water and condensation. (b) The electronics box is hanging freely.

6.11.2 Pulse Transmitter/Pulse Divider

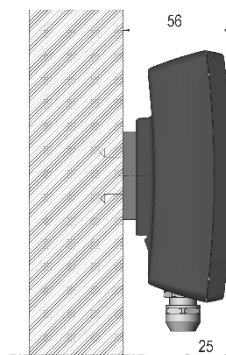

Figure 24. Pulse Transmitter/Pulse Divider mounted on fitting 3026-207.A

6.11.3 Insulation of ULTRAFLOW® 44 (Cooling installation)

The flow sensor ULTRAFLOW® 44 including the electronics box is particularly protected against wet conditions.

Nevertheless, the electronics box must NEITHER be mounted on the flow sensor NOR on pipes and due to EMC, it must NOT be mounted on cable trays, because the recommended minimum distance to other cables is 25 cm. Instead, we recommend mounting the electronics box elsewhere, e.g. fixed horizontally with cable strips on a grating. Note that thereby the type label is still visible.

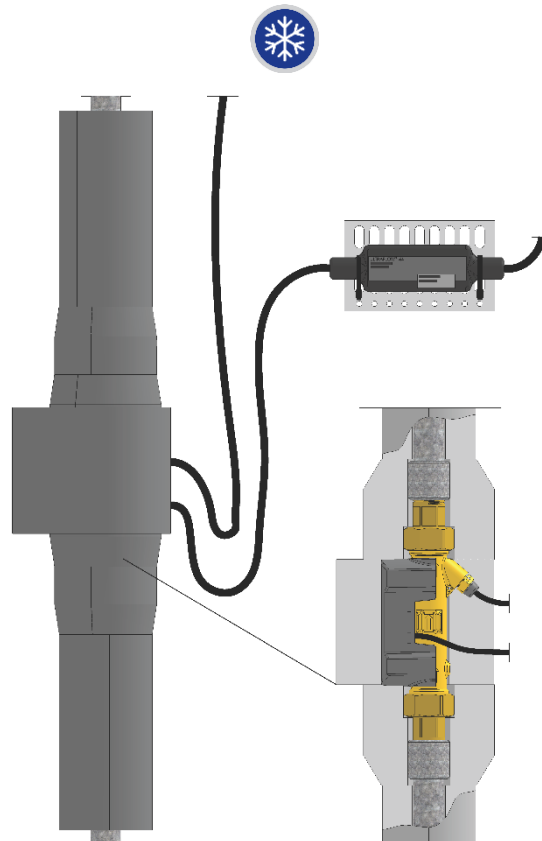

Figure 25: Insulation of ULTRAFLOW® 44 in a cooling installation.

The electronics box must NEITHER be mounted on the flow sensor NOR on pipes. Instead, it can hang freely on cables.

6.11.4 Insulation of ULTRAFLOW® 44 (Heat installation)

The electronics box must NEITHER be mounted on the flow sensor NOR on pipes. Instead, it can hang freely on cables.

⚠ If the medium temperature is above 110 °C ($T_{\text{medium}} > 110 \text{ °C}$), the plastic casing must NOT be insulated. Insulation of the plastic casing at a medium temperature above 110 °C can severely damage the plastic casing, because the temperatures inside the insulation get close to the glass transition temperature of the plastic casing.

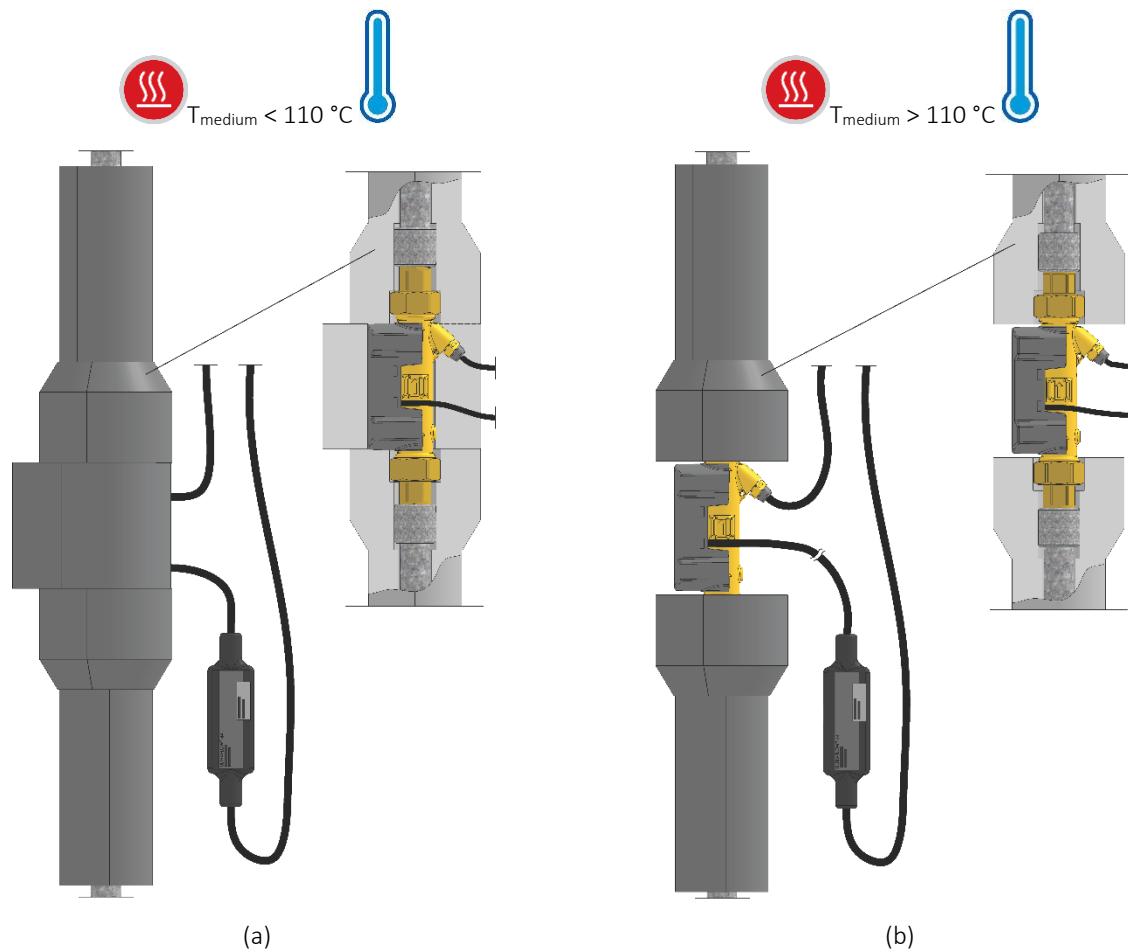

Figure 26: Insulation of ULTRAFLOW® 44 in a heat installation
(a) with $T_{\text{medium}} < 110 \text{ °C}$ and (b) with $T_{\text{medium}} > 110 \text{ °C}$.

6.12 Electrical connection

6.12.1 Electrical connection of ULTRAFLOW® and MULTICAL®

| ULTRAFLOW® | → | MULTICAL® |
|-----------------|---|-----------|
| Blue (ground) | → | 11 |
| Red (supply) | → | 9 |
| Yellow (signal) | → | 10 |

Table 25. Connection of ULTRAFLOW® and MULTICAL®.

⚠ Using long control cables, careful consideration is required in connection with installation. With a view to EMC, there must be a distance of **at least 25 cm** between control cables and all other cables.

6.12.2 Electrical connection of Pulse Transmitter and Pulse Divider

If ULTRAFLOW® and MULTICAL® are connected via Pulse Transmitter, ULTRAFLOW® is galvanically separated from MULTICAL® and the cable length between ULTRAFLOW® and MULTICAL® can be extended up to 110 m.

⚡ Flow-info is not possible if Pulse Transmitter/Pulse Divider is used.

If ULTRAFLOW® is connected to other equipment than MULTICAL®, always connect ULTRAFLOW® via Pulse Transmitter or Pulse Divider. For connection of Pulse Transmitter and Pulse Divider to other calculators, see paragraph 7.7 *Pulse output of Pulse Transmitter and Pulse Divider*.

| ULTRAFLOW® | → | Pulse Transmitter/ Pulse Divider ¹⁾ | | → | MULTICAL® |
|-----------------|---|---|--------|---|-----------|
| | | Input | Output | | |
| Blue (ground) | → | 11 | 11A | → | 11 |
| Red (supply) | → | 9 | 9A | → | 9 |
| Yellow (signal) | → | 10 | 10A | → | 10 |

Table 26. Connection of ULTRAFLOW® and MULTICAL® via Pulse Transmitter/Pulse Divider.

¹⁾ Pulse Divider is normally not used together with MULTICAL®.

6.12.3 Cable length

The maximum allowable cable length between Pulse Transmitter/Pulse Divider and MULTICAL® depends on the output module used in Pulse Transmitter/Pulse Divider as well as how the MULTICAL® calculator is connected.

| PT/PD output module | MULTICAL® 602/603/801/803 | |
|------------------------|---------------------------|-------------------|
| | 2-wire connection | 3-wire connection |
| Y=2 | < 100 m *) | < 10 m |
| Y=3 | N/A | < 10 m |

*) MULTICAL® 602 must have sensor connection type D and external 24 VDC supply.
 MULTICAL® 603 must have sensor connection type G and external 24 VDC supply.
 MULTICAL® 801 features 12 VDC auxiliary supply.
 MULTICAL® 803 features auxiliary supply via PCB 66-99-045.

Table 27. Maximum allowable cable length depends on the output module in Pulse Transmitter / Pulse Divider and how the MULTICAL® calculator is connected.

⚠ Using long signal cables, careful consideration is required in connection with installation. With respect to EMC, there must be a distance of **at least** 25 cm between signal cables and all other cables. Recommended cable cross section for the signal cable is 2 x 0.5 mm².

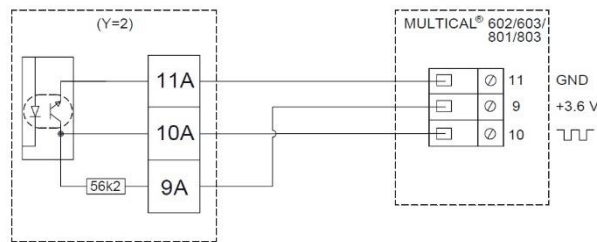

Figure 27. Three-wire connection of Pulse Transmitter with output module (Y=2) to MULTICAL® 602/603/801/803. Cable length < 10 m.

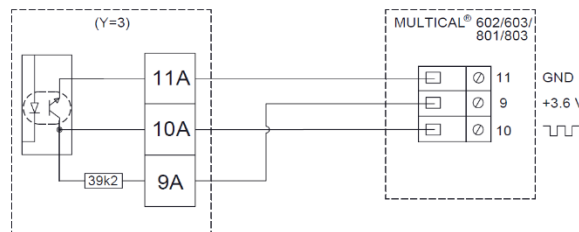

Figure 28. Three-wire connection of Pulse Transmitter with output module (Y=3) to MULTICAL® 602/603/801/803. Cable length < 10 m.

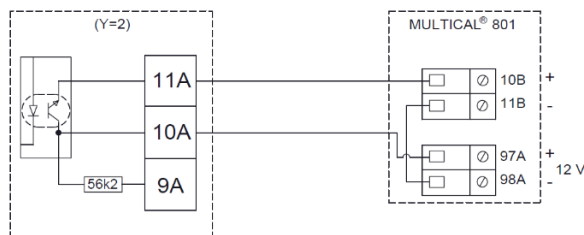

Figure 29. Two-wire connection of Pulse Transmitter with output module (Y=2) to MULTICAL® 801. Note the 12 VDC auxiliary supply in MULTICAL® 801. Cable length < 100 m.

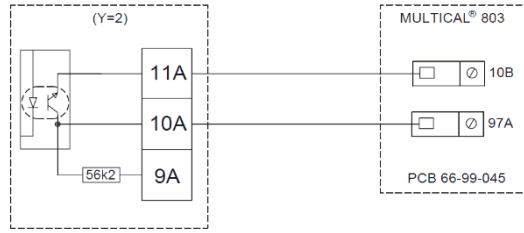

Figure 30. Two-wire connection of Pulse Transmitter with output module (Y=2) to MULTICAL® 803. Note the auxiliary supply in MULTICAL® 803 via PCB 66-99-045. Cable length < 100 m.

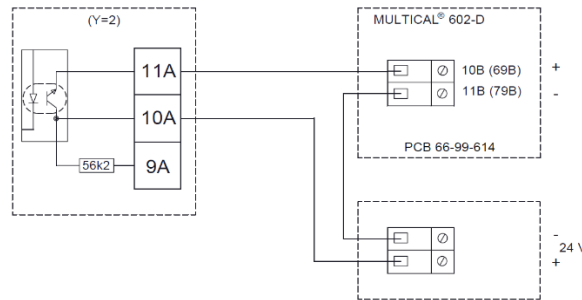

Figure 31. Two-wire connection of Pulse Transmitter with output module (Y=2) to MULTICAL® 602-D and external 24 VDC supply ¹⁾. Cable length < 100 m.

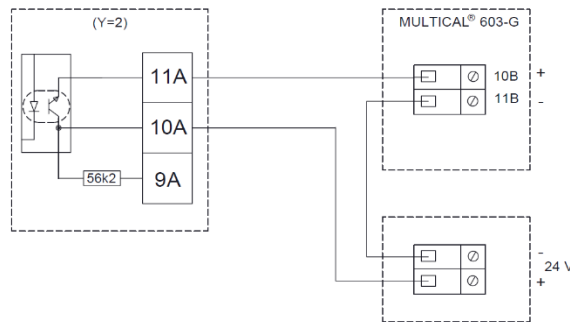

Figure 32. Two-wire connection of Pulse Transmitter with output module (Y=2) to MULTICAL® 603-G and external 24 VDC supply ¹⁾. Cable length < 100 m.

¹⁾ External 24 VDC supply is not part of the calculator.

Examples of connection of Pulse Transmitter appear from paragraph 6.13.2.

6.12.4 Connection of power supply

In case that ULTRAFLOW® is connected galvanically coupled to a MULTICAL® calculator, ULTRAFLOW® is supplied by MULTICAL®. If ULTRAFLOW® is connected via Pulse Transmitter or Pulse Divider, ULTRAFLOW® is supplied by the supply module/battery mounted in Pulse Transmitter/Pulse Divider.

6.12.4.1 Battery supply

Pulse Transmitter/Pulse Divider is fitted with a D-cell lithium battery with connector. The battery is connected to the output module.

Optimal battery lifetime is obtained by keeping the battery temperature below 30 °C, e.g. by wall-mounting of Pulse Transmitter/Pulse Divider.

The voltage of a lithium battery is almost constant throughout the lifetime of the battery (approx. 3.65 V). Therefore, it is not possible to determine the remaining capacity of the battery by measuring the voltage.

The battery cannot and must not be charged and must not be short-circuited.

The battery must be replaced by a corresponding lithium battery with connector from Kamstrup A/S. Used batteries must be handed in for approved destruction, e.g. to Kamstrup A/S (see chapter *12 Disposal*).

6.12.4.2 Mains supply modules

The mains supply modules are protection class II and are connected to the interface module via a short two-wire cable with connector. The modules are powered via a two-wire mains supply cable (without earth connection) through the cable connector of Pulse Transmitter/Pulse Divider. Use supply cable with an outer diameter of maximum 10 mm and ensure correct stripping of insulation as well as correct tightening of cable connection (see paragraph 6.12.4.4).

Max permitted fuse: 6 A.

ULTRAFLOW® 44 DN15-125

230 VAC

This PCB module is galvanically separated from the mains supply and is suitable for direct 230 V mains installation. The module includes a double-chamber safety transformer, which fulfils double insulation requirements when the cover is mounted on Pulse Transmitter/Pulse Divider. Power consumption is less than 1 W or 1 VA.

National regulations for electric installations must be observed. The 230 VAC module can be connected/disconnected by the district heating station's personnel, whereas the fixed 230 V installation in the main electrical panel must be carried out by an authorized electrician.

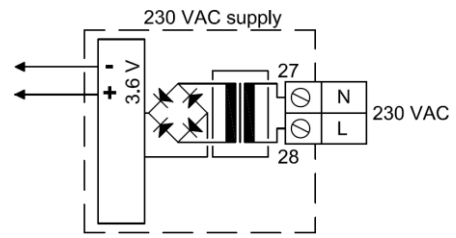

Figure 33. 230 VAC supply module for Pulse Transmitter/Pulse Divider

24 VAC

This PCB module is galvanically separated from the 24 VAC mains supply and is both suitable for industrial installations with joint 24 VAC supply and individual installations, which are supplied by a separate 230/24 V safety transformer in the main electrical panel. The module includes a double-chamber safety transformer, which fulfils double insulation requirements when the cover is mounted on Pulse Transmitter/Pulse Divider. Power consumption is less than 1 W or 1 VA.

National regulations for electric installations must be observed. The 24 VAC module can be connected/disconnected by the district heating station's personnel, whereas the fixed 230/24 V installation in the main electrical panel must be carried out by an authorized electrician.

⚡ This module cannot be supplied by 24 VDC (direct current).

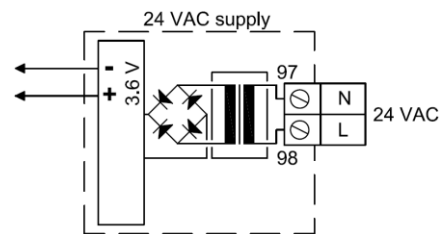

Figure 34. 24 VAC supply module for Pulse Transmitter/Pulse Divider

230/24 VAC safety transformer

The 24 VAC module is especially suited for installation together with a 230/24 VAC safety transformer, e.g. type 6699-403, which can be installed in the main electrical panel before the safety relay. When the transformer is used, the total power consumption of the meter incl. the 230/24 VAC transformer will not exceed 1.7 W.



Figure 35. 230/24 VAC safety transformer

6.12.4.3 Mains supply cable

Pulse Transmitter/Pulse Divider is available with mains supply cable H03 VV-F for either 24 VAC or 230 VAC (l=1.5 m).

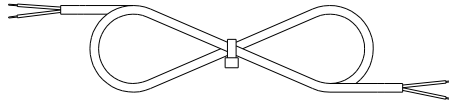

Figure 36. Mains supply cable (2 x 0.75 mm²), max 6 A fuse

“H03 VV-F” is the designation of a strong PVC mantle, which withstands max 70 °C. Therefore, the mains cable must be installed with sufficient distance to hot pipes, etc.

6.12.4.4 Cable screw connections

Cable dimension of control cable connections: 2...6 mm

Cable dimension of mains cable connections: 4.5...10 mm

Tightening torque: Maximum 4 Nm (traction relief minimum 40 N according to EN 61558)

⚠ In connection with battery supply, the unused cable connection must be sealed off as shown in *Figure 39*, page 59.

6.12.4.5 Change of supply unit

The supply unit of Pulse Transmitter/Pulse Divider can be changed from mains supply to battery or vice versa as the needs of the supply company change. Thus, it can be an advantage to change Pulse Transmitter/Pulse Divider from being mains-supplied to being battery-supplied, e.g. in case of buildings under construction where the mains supply can be unstable or periodically missing.

Note that the supply type appears from the label of Pulse Transmitter/Pulse Divider. If the original supply type is changed, it will no longer be in accordance with the label.

6.12.5 Electrical connection of Cable Extender Box

The Cable Extender Box 6699-036 is built up with transient transorb diodes, making it possible to extend the cable between ULTRAFLOW® and MULTICAL® up to 30 m in total, while the cable length without the Cable Extender Box can be maximum up to 10 m.

Fix Cable Extender Box to the wall or the like close to ULTRAFLOW®. Connect the 3 wires in the cable from ULTRAFLOW® to one of the terminals in Cable Extender Box. You can select any of the terminals. Use a 3-wire extension cable with a length of up to 27.5 m with the same wire diameter and of the same quality as the cable from ULTRAFLOW® and connect the 3 wires to the other terminal in Cable Extender Box. Connect the opposite end of the extension cable to the terminal (V1 or V2) in MULTICAL®. Connect the cables according to the following combination: 10: Yellow, 9: Red and 11: Blue. This colour combination applies to both Cable Extender Box and MULTICAL®. Perform a function check, and complete by sealing Cable Extender Box with the included void labels or the seal labels of the utility.

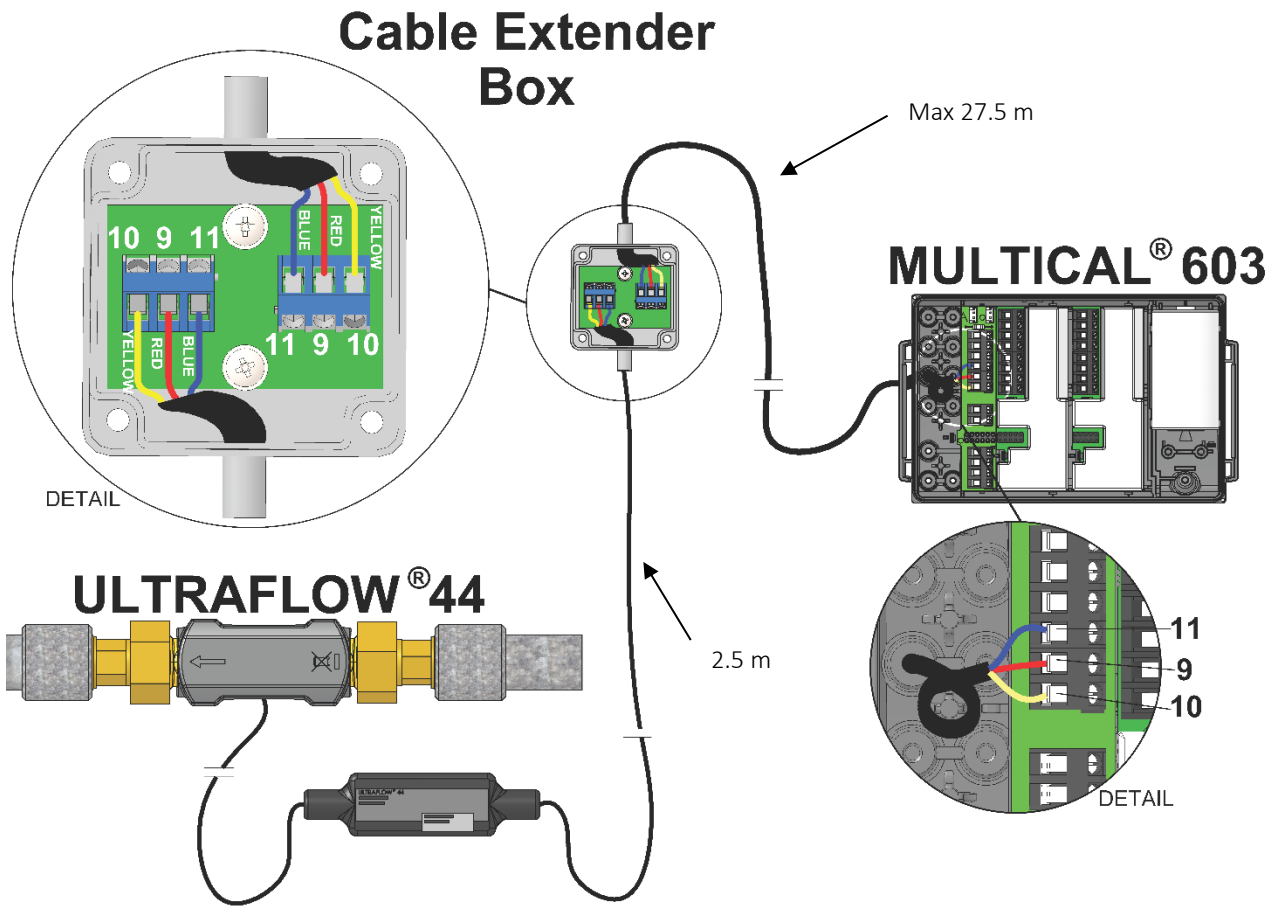

Figure 37. Electrical connection of ULTRAFLOW® to MULTICAL® via Cable Extender Box. The example illustrates a default 2.5 m cable from ULTRAFLOW® to Cable Extender Box. In this case, the cable length between Cable Extender Box and MULTICAL® can be up to max 27.5 m.

6.13 Installation examples (electrical)

6.13.1 Example of connection of ULTRAFLOW® and MULTICAL®

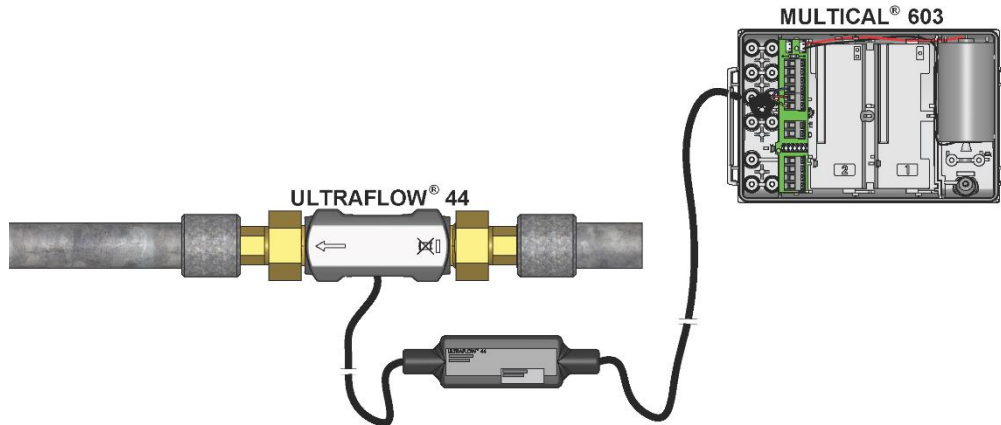

Figure 38. ULTRAFLOW® 44 (Type 65-4-XXHX-XXX) connected to MULTICAL® 603.

See also paragraph 6.12 Electrical connection of ULTRAFLOW® and MULTICAL®.

6.13.2 Example of connection of Pulse Transmitter

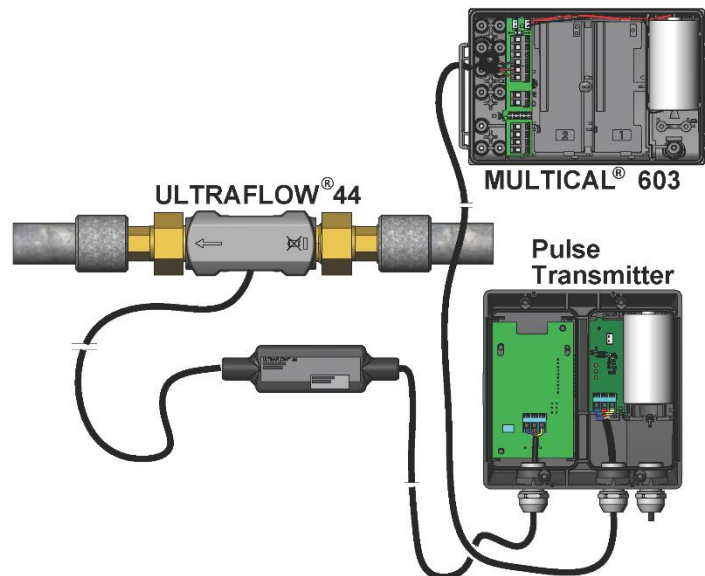

Figure 39. ULTRAFLOW® 44 (Type 65-4-XXHX-XXX) connected to Pulse Transmitter with battery supply. MULTICAL® 603 is connected to the Pulse Transmitter's output module (Y=3).

⚡ If battery-supplied, the right cable connection of Pulse Transmitter is plugged.

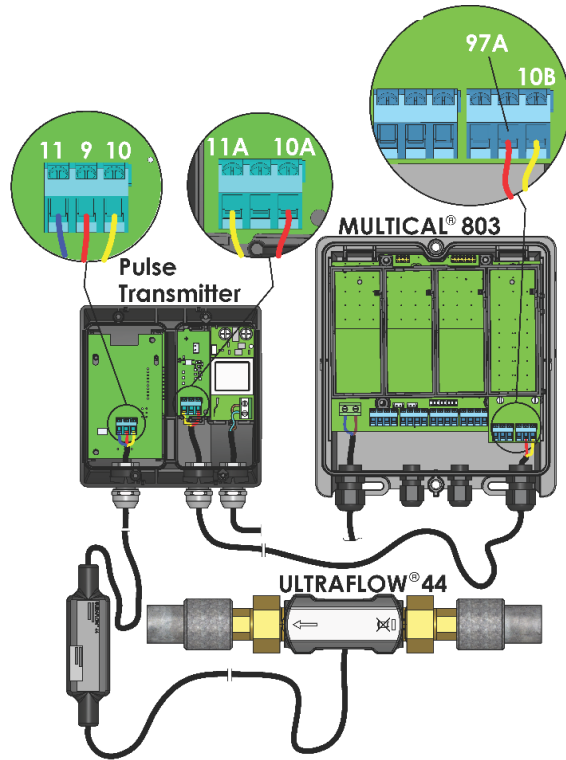

Figure 40. ULTRAFLOW® 44 (Type 65-4-XXHX-XXX) connected to Pulse Transmitter with 230 VAC supply. MULTICAL® 803 is connected to the Pulse Transmitter's output module (Y=2).

See paragraph 6.12.2 for electrical connection.

6.13.3 Calculator with two flow sensors

MULTICAL® 603 and 803 can be used in various installations with two flow sensors, e.g. leak monitoring or open systems. When two ULTRAFLOW® sensors are direct connected to one MULTICAL®, an equipotential connection (electric low impedance connection) between the two pipes should be carried out as a main rule to protect the meter electronics against transients and potential differences. If the two pipes are installed in a heat exchanger, close to the flow sensors, however, the heat exchanger will provide the necessary electric connection.

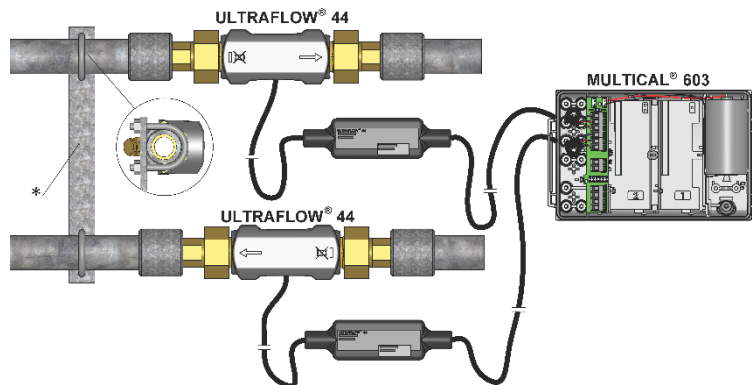

Figure 41. Direct electric connection of two ULTRAFLOW® to MULTICAL® in an installation with equipotential connection (electric low impedance connection) between the pipes*.

In installations where an equipotential connection cannot be carried out, the cable from one ULTRAFLOW® (typically V2) shall pass through a Pulse Transmitter with galvanic separation before the cable enters MULTICAL®.

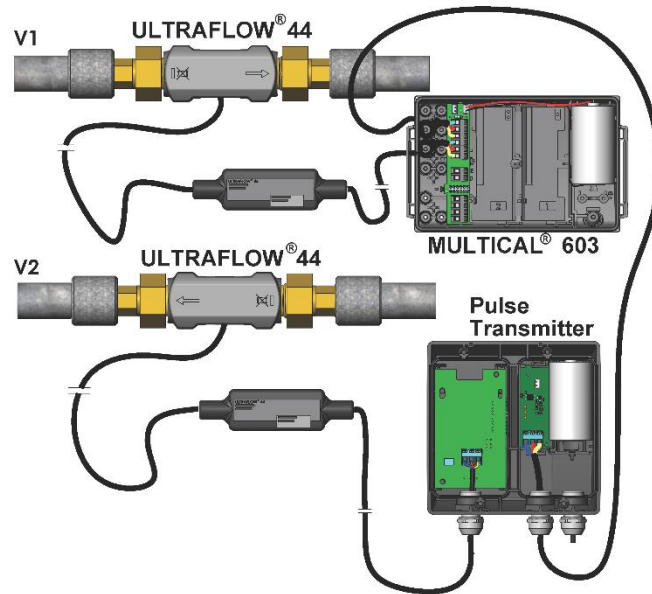

Figure 42. Installation of Pulse Transmitter for galvanic separation of one ULTRAFLOW® (typically V2) in installations, where an equipotential connection cannot be carried out.

6.13.4 Electric welding

If electric welding is performed, the signal cable from ULTRAFLOW® must always be disconnected from the MULTICAL® calculator terminal blocks while the welding is being performed. For meters with two ULTRAFLOW® flow sensors connected to the calculator, both ULTRAFLOW® signal cables must be disconnected.

⚠ Electric welding must always be carried out with the earth pole closest to the welding point. Damage to meters due to welding is **not** comprised by Kamstrup's factory guarantee.

6.14 Operational check

Carry out an operational check when the complete meter (flow sensor, temperature sensors and calculator) has been installed and connected. Open thermostats and valves so that water is flowing in the system and check that there are credible values for temperatures and water flow in the calculator display.

7 Functional description

Within the heat, cooling and water meter industry, producers have been working on alternative techniques for the replacement of flow sensors based on the mechanical principle. Research and development at Kamstrup have proven that ultrasonic measuring is the most viable solution. Combined with microprocessor technology and piezo ceramics, ultrasonic measuring is not only accurate but also reliable.

7.1 Flow measurement with ultrasound

Within ultrasonic flow measuring, there are two main principles: the transit time method and the Doppler method. The Doppler method is based on the frequency change which occurs when sound is reflected by a moving particle. This is the effect you experience when a car drives by. The sound (the frequency) decreases when the car passes by. The transit time method used in ULTRAFLOW® utilizes the fact that it takes an ultrasonic signal sent in the opposite direction of the flow longer to travel from sender to receiver than a signal sent in the same direction as the flow.

A piezo-ceramic element is used for transmitting and receiving ultrasound. The thickness of the element changes when exposed to an electric field (voltage) and thereby it functions as a transmitter of ultrasound. When the element is mechanically influenced, it generates a corresponding electric voltage and thus functions as a receiver of ultrasound.

7.2 Signal path, flow calculation and flow profiles

As shown by the calculations below, the average flow velocity is directly proportional to the transit time difference of ultrasound signals which are sent with or against the flow. *Figure 43* shows as example the U-shaped signal path and corresponding measuring tube assembly utilized in flow sensors of MULTICAL® 303, MULTICAL® 403 (q_p 0.6...2.5 m³/h) as well as ULTRAFLOW® 44 (q_p 1.5...2.5 m³/h) and ULTRAFLOW® 54 (type 65-5-XXHX-XXX, q_p 0.6...2.5 m³/h): Piezo-electric elements transmit and receive the ultrasound signal, which is reflected into and through the measuring tube to the receiver via reflectors. Due to superposition of velocities of water and sound signal, ultrasound propagates faster with the flow than against the flow.

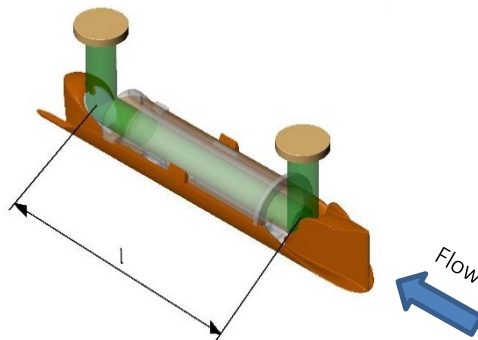

Figure 43. U-shaped signal path. Sound signals are transmitted by the transducers via 2 reflectors. The signal's transit times with and against the flow vary for the significant sound path distance (parallel with the measuring tube).

For the calculation of the transit time difference, the signal path along the flow is crucial, and the transit time to the measuring distance is calculated as:

$$t = \frac{l}{c \pm v}$$

where:

t is the transit time from sender to receiver of the sound signal along the measuring distance l . [s]

l is the measuring distance. [m]

c is the sound propagation velocity in stagnant water. [m/s]

v is the average flow velocity of water. [m/s]

The transit time difference can be expressed as the difference between the absolute time of the signal sent against the flow (-) and the signal sent with the flow (+).

$$\Delta t = \frac{l}{c - v} - \frac{l}{c + v}$$

which can also be written as:

$$\Delta t = l \frac{(c + v) - (c - v)}{(c - v) \cdot (c + v)} \Rightarrow \Delta t = l \frac{2v}{c^2 - v^2}$$

As $c^2 \gg v^2$, v^2 can be omitted and the formula reduced as follows:

$$v = \frac{\Delta t \cdot c^2}{2l}$$

Thus, we know the basic connection between the average flow velocity and the transit time difference.

The transit time difference in a flow sensor is very small (nanoseconds). Therefore, the time difference is measured as a phase difference between the two 1 MHz sound signals in order to obtain the necessary accuracy.

Furthermore, the influence of the temperature of the sound velocity of water must be taken into account. In ULTRAFLOW®, the velocity of ultrasound c is measured by means of a number of absolute time measurements between the two transducers. As the geometry of the flow sensor is known, the measured speed of the ultrasound is thus a scale for the water temperature, which is further used in the built-in ASIC in connection with the flow calculations.

The flow (volume flow rate) is then determined by measuring the transit time difference, calculating the average flow velocity and multiplying it by the area of the measuring tube:

$$q = v \cdot A$$

where:

q is the flow (volume flow rate). $\left[\frac{m^3}{h}\right]$

A is the area of the measuring pipe. $[m^2]$

The volume V passing through is finally calculated as a time integration over the flow (multiplication of cross section constant flow by time).

ULTRAFLOW® 44 DN15-125

The calculation above is simplified since it does not take into account the flow profiles. In general, flow profiles influence the measurement, which in our case is the transit time difference. Flow sensors are thus adjusted properly according to the different Reynolds numbers that characterise the flow, i.e. in practice for different flows (volume flow) and temperatures. To cover the various flow profiles in the best possible way with the ultrasound signal, Kamstrup uses a triangle sound path, as illustrated in *Figure 44* from two perspectives for large MULTICAL® 403, ULTRAFLOW® 44 and ULTRAFLOW® 54 flow sensors (qp 3.5...100 m³/h).

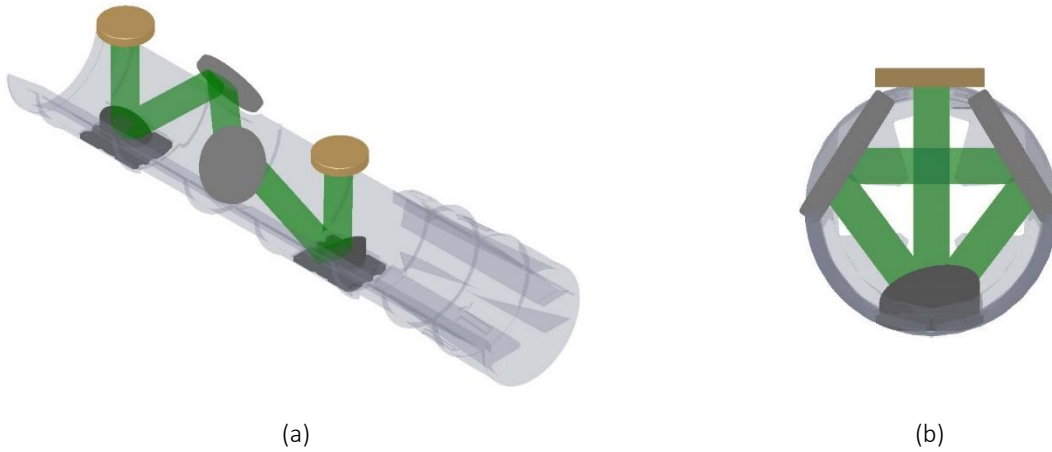

Figure 44. Triangular signal path shown from the side (a) and when looking into the measuring tube (b). Sound signals are transmitted by the transducers via 4 reflectors along the triangular path.

7.3 Function of ULTRAFLOW®

During a flow measurement, ULTRAFLOW® passes through a number of sequences, which are repeated at fixed intervals. Deviations only occur when the flow sensor is in test mode and when the supply is connected during initialization/start-up.

The difference between the main routines in normal mode and fast/test mode is the frequency of the measurements on which pulse emission is based.

In connection with Power Down, it may take up to 16 seconds to start with proper functioning.

In the flow sensor's working range from min. cut off to saturation flow, there is a linear connection between the flow rate and the number of pulses being emitted. The diagram below shows an example of the connection between flow and pulse frequency for ULTRAFLOW® $q_p 1.5 \text{ m}^3/\text{h}$ (Figure 45).

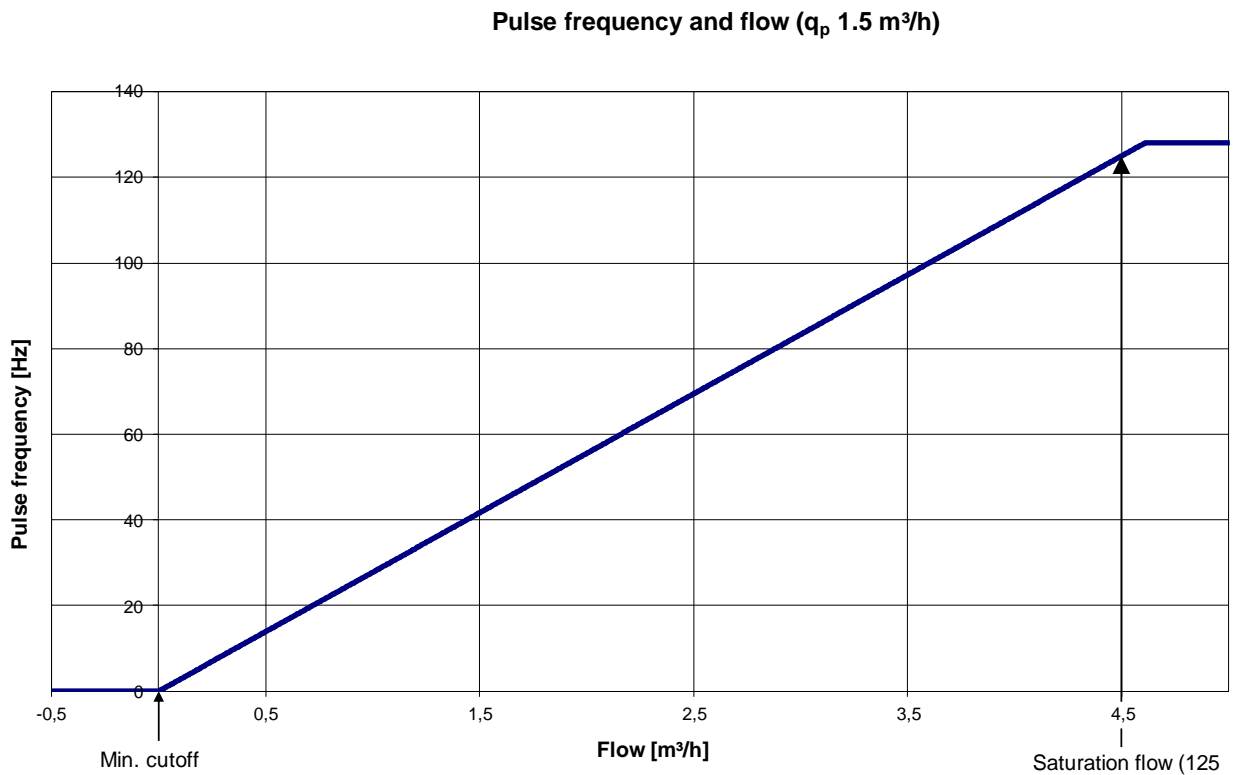

Figure 45. Pulse frequency as a function of flow $q_p 1.5 \text{ m}^3/\text{h}$.

If the flow is lower than min. cut off or negative (backward flow), ULTRAFLOW® does not emit pulses.

At flows exceeding the flow corresponding to pulse emission at max pulse frequency, the max pulse frequency will be maintained.

Table 28 shows the saturation flow at a pulse frequency of 125 Hz for the different flow sizes and meter factors.

| q_p [m³/h] | Meter factor [p/l] | Flow at 125 Hz [m³/h] |
|---------------------------------------|-------------------------------------|--|
| 0.6 | 300 | 1.50 |
| 1.5 | 100 | 4.50 |
| 2.5 | 60 | 7.50 |
| 3.5 | 50 | 9.00 |
| 6 | 25 | 18.0 |
| 10 | 15 | 30.0 |
| 15 | 10 | 45.0 |
| 25 | 6 | 75.0 |
| 40 | 5 | 90.0 |
| 60 | 2.5 | 180 |
| 100 | 1.5 | 300 |

Table 28. Flow at saturation (125 Hz). Note that flow sensors with q_p 0.6 are not created for ULTRAFLOW® 44.

According to EN 1434, the upper flow limit q_s is the highest flow at which the flow sensor may operate for short periods of time (< 1h/day, < 200h/year) without exceeding maximum permissible errors. ULTRAFLOW® has no functional limitations during the period when the flow sensor operates above q_p.

Please note, however, that high flow velocities may cause cavitation, especially at low static pressure. See paragraph 6.1.4 *Operating pressure*.

7.4 Pulse emission

Pulses are emitted at 1-second intervals. The number of pulses to be emitted is calculated every second. Pulses are emitted in bursts with a pulse duration of 2...6 ms and pauses depending on the current pulse frequency. The duration of the pauses between the individual bursts is approx. 30 ms.

The transmitted pulse signal is the average determination of a series of flow measurements. This means that there will be a transient phenomenon until correct flow signal has been obtained during start-up. Furthermore, this brings about a pulse tail of up to 8 seconds in case of sudden hold.

7.5 Supply and power consumption of ULTRAFLOW®

Normally, ULTRAFLOW® is supplied either via the connected MULTICAL® calculator or Pulse Transmitter/Pulse Divider. When ULTRAFLOW® is supplied in any other way, for example via direct connection in a flow bench, the following applies:

Internal supply voltage of ULTRAFLOW®:

3.6 VDC ±0.1 VDC

The current consumption of ULTRAFLOW®:

Max average 50 µA
 Max current 7 mA (max 40 ms)

7.6 Pulse output of ULTRAFLOW®

ULTRAFLOW®

| | |
|-------------------|---|
| Type | Push-Pull |
| Output impedance | ~10 kΩ |
| Pulse duration | 2...6 ms |
| Duration of pause | Depending on the actual pulse frequency |

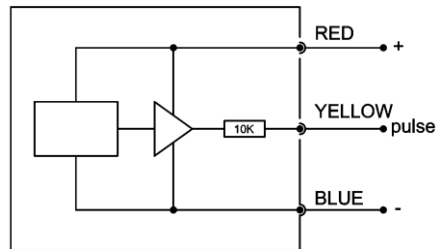

Figure 46. Block diagram for ULTRAFLOW®

7.7 Pulse output of Pulse Transmitter and Pulse Divider

7.7.1 Galvanically separated output module (Y=2)

Pulse Transmitter/Pulse Divider is powered by the built-in supply module (Z=7 or 8).

The cable length to Pulse Transmitter/Pulse Divider depends on the calculator.

To calculator:

Type: Open collector.

Connection: Can be connected as two-wire or three-wire via the built-in 56.2 kΩ pull-up.

| Module Y=2 | OC and OD | (OB) Kam |
|-------------------|--|--|
| Max input voltage | 6 V | 30 V |
| Max input current | 0.1 mA | 12 mA |
| ON condition | $U \leq 0.3 \text{ V @ } 0.1 \text{ mA}$ | $U_{CE} \leq 2.5 \text{ V @ } 12 \text{ mA}$ |
| OFF condition | $R \geq 6 \text{ M}\Omega$ | $R \geq 6 \text{ M}\Omega$ |

Table 29

Concerning meter factors and pulse durations, see paragraph 4.3.4 Pulse Divider configuration CCC-DD-E-MMM.

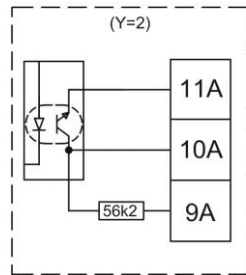

Figure 47. Block diagram for galvanically separated output module (Y=2).

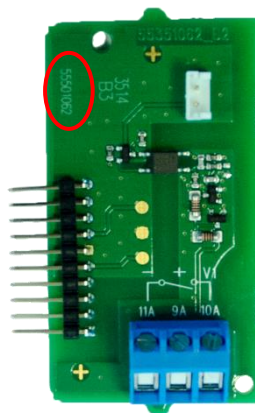

Figure 48. Galvanically separated output module (Y=2).
Note the PCB number 5550-1062 in the encircled area.

7.7.2 Galvanically separated output module (Y=3)

Pulse Transmitter/Pulse Divider is powered by the built-in supply module (Z=2, 7 or 8).

The cable length to Pulse Transmitter/Pulse Divider depends on the calculator.

To calculator:

Type: Open collector.

Connection: Three-wire connection is possible via the built-in 39.2 kΩ pull-up.

| Module Y=3 | OC and OD |
|-------------------|--|
| Max input voltage | 6 V |
| Max input current | 0.1 mA |
| ON condition | $U \leq 0.3 \text{ V @ } 0.1 \text{ mA}$ |
| OFF condition | $R \geq 6 \text{ M}\Omega$ |

Table 30

Concerning meter factors and pulse durations, see paragraph 4.3.4 Pulse Divider configuration CCC-DD-E-MMM.

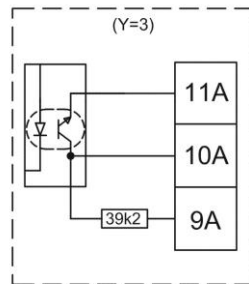

Figure 49. Block diagram for galvanically separated output module (Y=3).

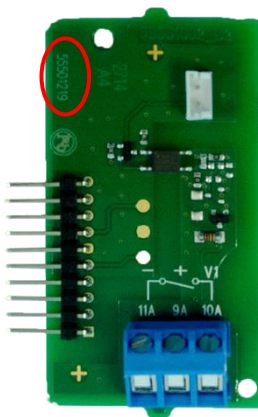

Figure 50. Galvanically separated output module (Y=3). Note the PCB number 5550-1219 in the encircled area.

7.8 Interface connector, test mode and serial data

ULTRAFLOW® 44 has no interface connector due to complete encapsulation of the PCB rendering the flow sensor waterproofed. Instead, the 3-wire signal cable from ULTRAFLOW® is utilized for:

- Bringing the sensor into test mode (only at Kamstrup)
- External control of start/stop in connection with calibration
- Reading accumulated water quantity in connection with calibration (only at Kamstrup)
- Meter programming, including adjustment of flow charts by means of Kamstrup software (see 8.6 *Adjustment of ULTRAFLOW® flow sensors with Kamstrup software*)

☀ The communication to ULTRAFLOW® 44 must in praxis be facilitated by a connected MULTICAL® 603 or 803 calculator. This means that direct communication via the 3-wire signal cable from ULTRAFLOW® is not supported. For further details see paragraph 8.6 *Adjustment of ULTRAFLOW® flow sensors with Kamstrup software*

7.9 Accuracy

ULTRAFLOW® has been developed as a volume flow rate sensor for energy meters according to EN 1434. The tolerances permitted for flow sensors according to EN 1434 with a dynamic range of 100:1 ($q_p:q_i$) and q_p 1,5 m³/h are shown in *Figure 51*. The tolerances are defined for class 2 and class 3 with following formulas:

Class 2: $\pm \left(2 + 0,02 \cdot \frac{q_p}{q} \right)$ %, however max ± 5 %

Class 3: $\pm \left(3 + 0,05 \cdot \frac{q_p}{q} \right)$ %, however max ± 5 %

EN 1434 defines the following dynamic ranges ($q_p:q_i$): 10:1, 25:1, 50:1, 100:1 and 250:1.

In connection with accuracies, the range from q_p to q_s is defined as max flow, where the meter must short-term (< 1 h/day; < 200 h/ year) be functioning and tolerances are adhered to. There are no requirements for the relation between q_p and q_s . See *Table 1* for information on q_s for ULTRAFLOW®.

To render probable that the sensors meet the tolerance requirements, EN 1434-5 specifies calibration requirements in connection with verification of sensors. It is required that flow sensors are tested at the following 3 points:

$$q_i \dots 1.1 \times q_i, 0.1 \times q_p \dots 0.11 \times q_p \text{ and } 0.9 \times q_p \dots q_p$$

During test, the water temperature must be 50 °C \pm 5 °C for ULTRAFLOW® as a heat meter.

For ULTRAFLOW® as a cooling meter, the water temperature must be 15 °C \pm 5 °C.

Further requirements are that the tolerance of the equipment used to perform the test must be less than 1/5 MPE (Maximum Permissible Error) to permit the acceptance limit to be equal to MPE. If the equipment does not observe 1/5 MPE, the acceptance limit must be reduced by the tolerance of the equipment.

ULTRAFLOW® will typically do better than half of the permitted tolerance according to EN 1434 class 2.

☀ For further information regarding allowable test conditions such as water temperature and flow of the individual ULTRAFLOW®, see the approval of ULTRAFLOW® (see chapter 10 *Approvals*).

Flow sensor tolerances $q_p:q_i$ 100:1 (q_p 1.5 m³/h)

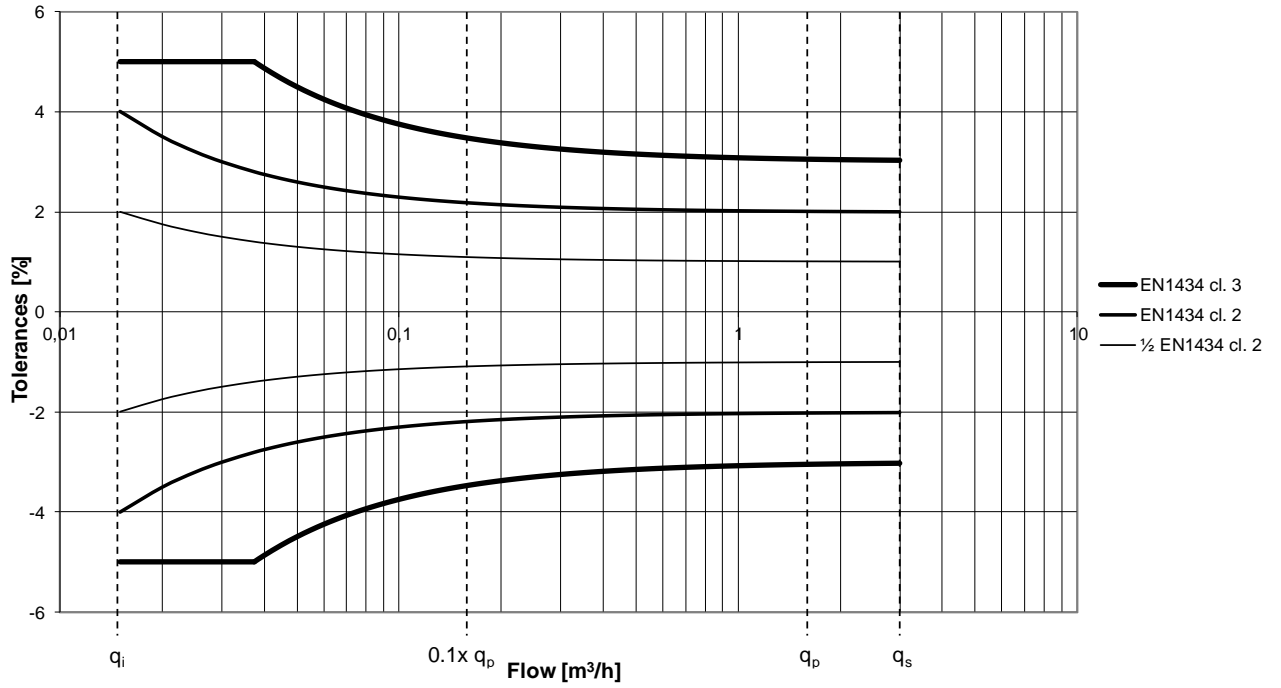

Figure 51. Flow sensor tolerances specified as an example for a flow sensor with q_p 1.5 m³/h and $q_p:q_i = 100:1$.

8 Calibration, adjustment and sealing of ULTRAFLOW®

Calibration can be based on:

- Pulses in standard mode.
- Pulses in test mode.
- Pulses using Pulse Tester type 6699-279.
- Serial data with the meter in test mode (only at Kamstrup).

8.1 Technical data for ULTRAFLOW®

ULTRAFLOW® emits flow-proportional pulses in accordance with *Table 31*. If ULTRAFLOW® is connected to equipment other than MULTICAL® calculators, for example a flow bench, it is recommended to use galvanic separation via Pulse Transmitter or Pulse Divider.

| q_p [m³/h] | Meter factor [p/l] |
|---------------------------------------|-------------------------------------|
| 0.6 | 300 |
| 1.5 | 100 |
| 2.5 | 60 |
| 3.5 | 50 |
| 6 | 25 |
| 10 | 15 |
| 15 | 10 |
| 25 | 6 |
| 40 | 5 |
| 60 | 2.5 |
| 100 | 1.5 |

Table 31. Output signal. Note that flow sensors with q_p 0.6 are not created for ULTRAFLOW® 44.

Output ULTRAFLOW®

| | |
|-------------------|---|
| Type | Push-Pull |
| Output impedance | ~10 kΩ |
| Pulse duration | 2...6 ms |
| Duration of pause | Depending on the actual pulse frequency |

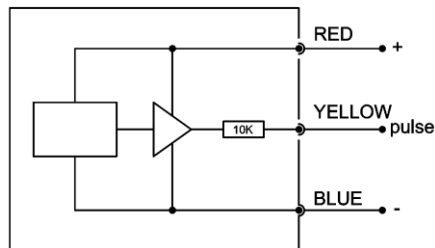

Figure 52. Block diagram for ULTRAFLOW®

☀ From start-up, it takes minimum 16 seconds until true flow reading has been reached and calibration can start. In addition, the calibration duration must be at least 2 minutes to obtain the correct flow measurement, but a minimum test time of 3 minutes is recommended. See paragraph 8.3 *Suggested test points* for further information about suggested test points.

8.2 Electrical connection

Connection via 3-wire cable from ULTRAFLOW®

| | |
|--------|------------------|
| Yellow | Signal |
| Red | Supply |
| Blue | Ground |
| Supply | 3.6 VDC ±0.1 VDC |

Output using Pulse Transmitter/Pulse Divider with galvanically separated output module (Y=2)

Type Open collector. Two-wire or three-wire connection is possible via the built-in 56.2 kΩ pull-up resistor.

| Module Y=2 | OC and OD | (OB) Kam |
|-------------------|--|--|
| Max input voltage | 6 V | 30 V |
| Max input current | 0.1 mA | 12 mA |
| ON condition | $U \leq 0.3 \text{ V @ } 0.1 \text{ mA}$ | $U_{CE} \leq 2.5 \text{ V @ } 12 \text{ mA}$ |
| OFF condition | $R \geq 6 \text{ M}\Omega$ | $R \geq 6 \text{ M}\Omega$ |

Table 32

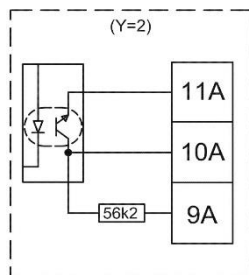

Figure 53. Block diagram for galvanically separated output module (Y=2).

Output using Pulse Transmitter/Pulse Divider with galvanically separated output module (Y=3)

Type Open collector. Three-wire connection via the built-in 39.2 kΩ pull-up resistor.

| Module Y=3 | OC and OD |
|-------------------|--|
| Max input voltage | 6 V |
| Max input current | 0.1 mA |
| ON condition | $U \leq 0.3 \text{ V @ } 0.1 \text{ mA}$ |
| OFF condition | $R \geq 6 \text{ M}\Omega$ |

Table 33

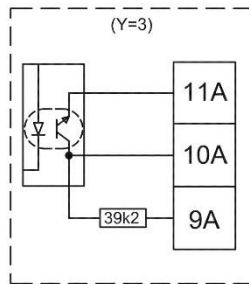

Figure 54. Block diagram for galvanically separated output module (Y=3).

8.3 Suggested test points

| Nom. flow q_p [m³/h] | Meter factor [pulses/l] | Test point | | | Test duration | | | Test quantities | | |
|------------------------------|----------------------------|-----------------|-----------------|----------------------------|----------------|----------------|---------------------------|-----------------|---------------|--------------------------|
| | | q_p [m³/h] | q_i [m³/h] | $0.1 \times q_p$ [m³/h] | q_p [min] | q_i [min] | $0.1 \times q_p$ [min] | q_p [kg] | q_i [kg] | $0.1 \times q_p$ [kg] |
| 0.6 | 300 | 0.6 | 0.006 | 0.06 | 3 | 20 | 6 | 30 | 2 | 6 |
| 1.5 | 100 | 1.5 | 0.015 | 0.15 | 3 | 20 | 6 | 75 | 5 | 15 |
| 2.5 | 60 | 2.5 | 0.025 | 0.25 | 3 | 20.2 | 6 | 125 | 8.4 | 25 |
| 3.5 | 50 | 3.5 | 0.035 | 0.35 | 3 | 17.1 | 6 | 175 | 10 | 35 |
| 6 | 25 | 6 | 0.06 | 0.6 | 3 | 20 | 6 | 300 | 20 | 60 |
| 10 | 15 | 10 | 0.1 | 1 | 3 | 20.4 | 6 | 500 | 34 | 100 |
| 15 | 10 | 15 | 0.15 | 1.5 | 3 | 20 | 6 | 750 | 50 | 150 |
| 25 | 6 | 25 | 0.25 | 2.5 | 3 | 20.2 | 6 | 1250 | 84 | 250 |
| 40 | 5 | 40 | 0.4 | 4 | 3 | 15 | 6 | 2000 | 100 | 400 |
| 60 | 2.5 | 60 | 0.6 | 6 | 3 | 20 | 6 | 3000 | 200 | 600 |
| 100 | 1.5 | 100 | 1 | 10 | 3 | 20 | 6 | 5000 | 333 | 1000 |

Table 34. ULTRAFLOW® test parameters including suggested test points, test durations and test quantities.

The suggested test parameters are based on EN 1434-5 and $q_p:q_i$ 100:1.

The test set-ups have been selected on the basis of the following requirements:

- Minimum test duration of 3 minutes
- Water volumes at q_i and $0.1 \times q_p$ of minimum 10 % of the water volume per hour
- Water volume at $0.1 \times q_p$ corresponding to minimum 1000 pulses
- Water volume at q_i corresponding to minimum 500 pulses

These suggested test points can be optimised for the test benches as well as for the test purpose.

8.4 Optimisation in connection with calibration

To make a rational test of ULTRAFLOW®, it must be possible to reproduce the test results. This is also very important if the tested sensors are to be adjusted.

Experience based on 300...500 pulses at q_i , 3000...5000 at q_p , and flying start/stop shows that ULTRAFLOW® operates with standard deviations of 0.3...0.4 % at q_i and 0.2...0.3 % at q_p .

In connection with the optimisation of calibration, the following subcomponents can be considered:

Pressure: Optimal working pressure is 4...6 bar of static pressure. This minimises the risk of air and cavitation.

Temperature: Calibration temperature according to EN 1434-5 is $50\text{ °C} \pm 5\text{ °C}$ for heat meters and $15\text{ °C} \pm 5\text{ °C}$ for cooling meters.

☀ For further information regarding allowable test conditions such as water temperature and flow of the individual ULTRAFLOW®, see the approval of ULTRAFLOW® (see chapter 10 Approvals).

Water quality: Recommended water quality as described in CEN TR 16911 and AGFW FW510

Installation (mechanical conditions):

To avoid flow disturbances, the inlet pipes and distance pieces must have the same nominal diameter as the sensors (see Table 35). There should be min. 5 x DN between the sensors. In connection with bends, etc., there should be a minimum distance of 10 x DN. If tests are made at low flow with a bypass at right angles to the pipe, it will be an advantage to mount an absorber of pressure fluctuations caused by the perpendicular inlet. This can be a flexible tube on the bypass. In addition, it will be an advantage to mount a flow straightener before the first distance piece. Flow disturbances such as pulsations, e.g. pump fluctuations must be minimised. In connection with calibration, a code of practice for distance pieces has been made on the basis of many years' experiences:

The lengths of the distance pieces must be 10 x DN.

The diameter of the distance pieces must be:

| Connection | Distance piece |
|--|----------------|
| G $\frac{3}{4}$ B (R $\frac{1}{2}$) DN15 | ø15 |
| G1B (R $\frac{3}{4}$) DN20 | ø20 |
| DN20 | ø20 |
| G $\frac{5}{4}$ B (R1) DN25 | ø25 |
| DN25 | ø25 |
| G1 $\frac{1}{2}$ B (R $\frac{5}{4}$) DN32 | ø32 |
| DN32 | ø32 |
| G2B (R1 $\frac{1}{2}$) DN40 | ø40 |
| DN40 | ø40 |
| DN50 | ø50 |
| DN65 | ø65 |
| DN80 | ø80 |
| DN100 | ø100 |
| DN125 | ø125 |

Table 35. Distance pieces.

At horizontal mounting of ULTRAFLOW® 44, which is typical for a flow bench, pay special attention to Figure 17 and Figure 18. Note that ULTRAFLOW® must **NOT** be evacuated (exposed to vacuum).

Installation (electrical conditions):

To avoid disturbances from the outside as well as to obtain an electrical interface like MULTICAL®, it is recommended to use a Pulse Tester (see paragraph 8.5) or to connect a Pulse Transmitter (see paragraph 4.3) between ULTRAFLOW® and the relevant test equipment that counts up pulses to achieve galvanic separation.

8.5 Pulse Tester

During a calibration process, it is often practical to use Pulse Tester type no. 6699-279, which has the following functions:

- Galvanically separated pulse outputs
- Integral supply for ULTRAFLOW®
- LCD display with counter
- Externally controlled "Hold" function
- Can be fitted directly on a MULTICAL® base unit (type 66- and 602-)

8.5.1 Technical data for Pulse Tester

Pulse inputs (M1/M2)

| | |
|-----------------|-------------------------|
| Counter inputs | Max frequency: 128 Hz |
| Active signal | Amplitude: 2.5 - 5 Vpp |
| Pulse duration | > 1 ms |
| Passive signal | Internal pull-up 680 kΩ |
| Internal supply | 3.65 V lithium battery |

⚡ Depending on the connecting base used, there will be one or two pulse inputs/outputs.

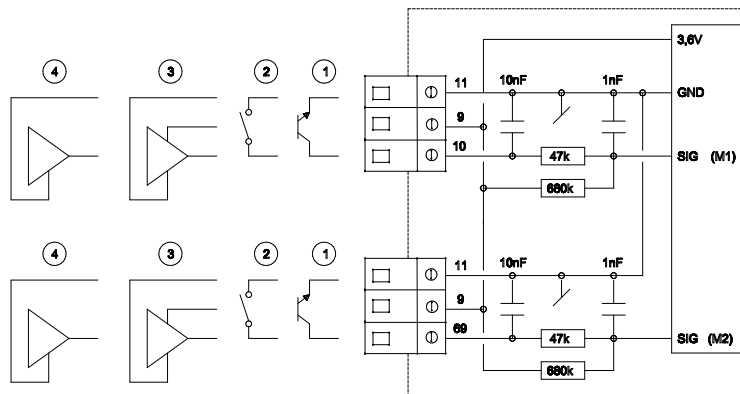

Figure 55

1 Flow sensor with transistor output

The transmitter is normally an optocoupler with FET or transistor output to be connected to terminals 10 and 11 for flow sensor M1 and terminals 69 and 11 for flow sensor M2.

The leak current of the transistor must not exceed 1 μA in OFF-state, and U_{CE} in ON-state must not exceed 0.5 VDC.

2 Flow sensor with relay or reed switch output

The transmitter is a reed switch, which is normally mounted on vane wheel and Woltmann meters, or relay output from e.g. MID meters. This type of transmitter should not be used as the quick pulse input may cause bounce problems.

3 **Flow sensor with active pulse output, powered by Pulse Tester**

This connection is used together with either Kamstrup's ULTRAFLOW® or Kamstrup's electronic pick-up for vane wheel meters.

| | | | |
|-----------------|-------------|------------------|----------------|
| Connection (M1) | 9: Red (9A) | 10: Yellow (10A) | 11: Blue (11A) |
| Connection (M2) | 9: Red (9A) | 69: Yellow (10A) | 11: Blue (11A) |

Table 36

4 **Flow sensor with active output and integral supply**

Flow sensors with active signal output are connected as shown in *Figure 55*. The signal level must be between 3.5 and 5 V. Higher signal levels can be connected via a passive voltage divider, e.g. 47 kΩ/10 kΩ at signal level 24 V.

Pulse outputs (M1/M2)

Pulse duration > 4 ms
 Duration of pause Depending on the actual pulse frequency

Two-wire connection:

Voltage < 24 V
 Load > 1.5 kΩ

Three-wire connection:

Voltage 5...30 V
 Load > 5 kΩ

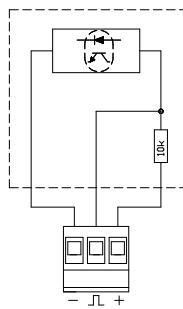

Figure 56

The outputs are galvanically separated and protected against overvoltage and reversed polarity.

Max counter capacity before overflow is 9,999,999 counts.

8.5.2 Hold function

When the Hold input is activated (high level applied to input), counting stops at the number of pulses counted.

When the Hold signal is removed (low level applied to input), counting restarts.

The counters can also be reset by pressing the right push-button on the front panel (Reset).

| | |
|------------------|---------------------------|
| Hold input | Galvanically separated |
| Input protection | Against reversed polarity |
| “Open input” | Count (see Figure 57) |

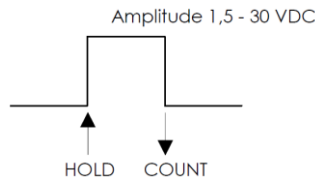

Figure 57

8.5.3 Push-button functions

The left push-button shifts between readings/counts of the two flow sensor inputs. In the display, M1 and M2 respectively indicate the currently displayed flow sensor inputs/counters.



Figure 58. The left push-button.

The right push-button resets both counters (M1 and M2).



Figure 59. The right push-button.

8.5.4 Use of Pulse Tester

Pulse Tester can be used as follows:

Standing start/stop of the flow sensor using the integral pulse counters.

Standing start/stop of the flow sensor using the pulse outputs for external test equipment.

With flying start/stop of the flow sensor using the integral counters controlled by external equipment (Sample & Hold).

With flying start/stop of the flow sensor using the pulse outputs controlled by external equipment (Sample & Hold).

8.5.5 Spare parts

| Description | Type No. |
|--------------------------------------|----------|
| Battery D-cell | 1606-064 |
| Cable retainer (secures the battery) | 1650-099 |
| 2-pole plug (female) | 1643-185 |
| 3-pole plug (female) | 1643-187 |
| Base PCB (66-R) | 5550-517 |

Table 37. Spare parts for Pulse Tester.

8.5.6 Battery replacement

If Pulse Tester is used continuously, it is recommended to replace the battery once a year.

The battery connector is cut and the cable insulation is removed before the battery is connected to the terminals marked "Batt", the red wire to + and the black wire to -.

Current consumption:

| | |
|---|-------------|
| Current consumption with no sensors connected | 400 μ A |
| Max current consumption with two ULTRAFLOW® connected | 1.5 mA |

⚡ If the base unit is fitted with battery or externally supplied, the Pulse Tester's integral supply must be disconnected (unplugged).

8.6 Adjustment of ULTRAFLOW® flow sensors with Kamstrup software

8.6.1 Introduction

Adjusting of ULTRAFLOW® flow sensors is supported from Kamstrup for authorized laboratories. The adjustment is performed by Kamstrup's software LabTool. Please contact the Product Service of Kamstrup A/S in Denmark (service@kamstrup.com) for additional information.

⚡ To prevent any attempt of fraud LabTool is exclusively distributed to workshops/laboratories with national legal authorization and partnership with Kamstrup.

8.6.2 Adjustment of ULTRAFLOW® 44

Adjusting of ULTRAFLOW® 44 requires individual encryption keys. In case that the serial numbers of the attached MULTICAL® calculator and the ULTRAFLOW® 44 flow sensor are identical, i.e. MULTICAL® and ULTRAFLOW® 44 are paired from the factory, the encryption key of ULTRAFLOW® 44 is stored in the calculator, and adjusting is facilitated by breaking the legal seal of the MULTICAL® calculator, setting it into test mode and communicating directly with ULTRAFLOW® 44 via the optical read-out head mounted on the MULTICAL® calculator. To distinguish between calculator and flow sensor in Kamstrup's data base, the serial number of ULTRAFLOW® 44 utilizes in this case a prefix (33).

To adjust a separate ULTRAFLOW® 44, the owner of the meter needs to contact Kamstrup's 1st level support (mykamstrup@kamstrup.com) to either receive the encryption key of the individual ULTRAFLOW® 44 or to ask Kamstrup to send it to an authorized laboratory, which should perform the adjustment. For further details about this process please consult Kamstrup's 1st level support (mykamstrup@kamstrup.com). The serial numbers of separate ULTRAFLOW® 44 are from an entirely different group than those for MULTICAL® calculators and do therefore not need a prefix. To communicate to the separate ULTRAFLOW® 44 a MULTICAL® 603/803 calculator needs to be connected. By means of the individual encryption key you can now adjust ULTRAFLOW® 44 with LabTool.

8.7 Sealing and marking

ULTRAFLOW® is sealed from the factory. Verified sensors will be supplied with security seals and a year mark as shown below.

If the seal of a verified sensor is broken, the sensor must be reverified before being installed in a location demanding verification.

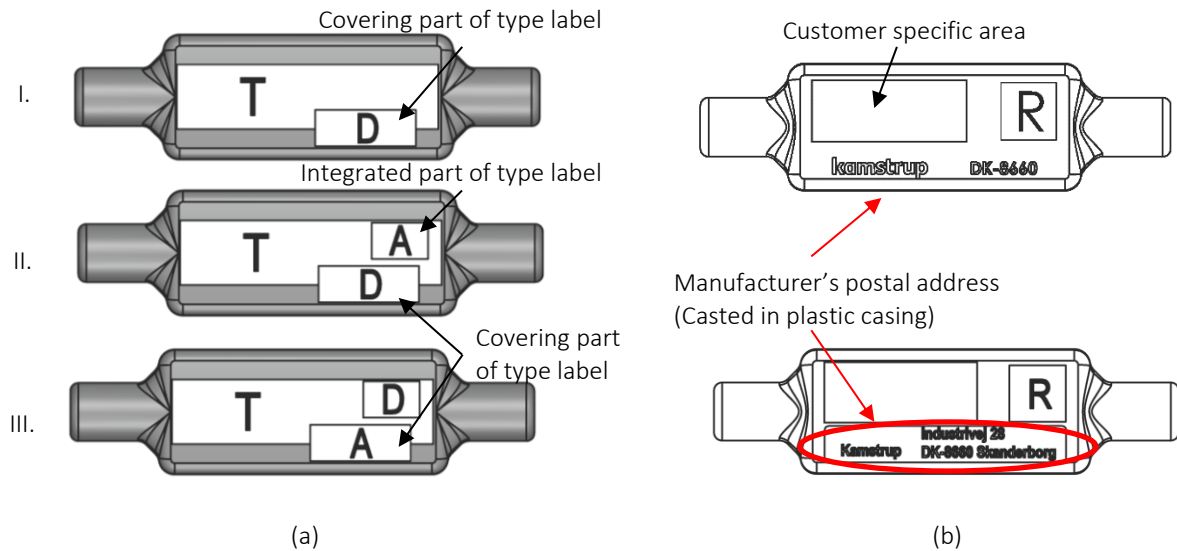

Figure 60. Sealing and markings of (a) front side and (b) rear side of the electronics box of ULTRAFLOW® 44. Note that the manufacturer postal address is cast in the rear side of the plastic casing. Furthermore, a customer label can also be placed on the rear side.

⚡ The encapsulation of the PCB serves in addition to water resistance as a legal seal, because any attempt of fraud to get access to the PCB will be visible by physical damage.

In the drawings, sealing is divided into the following groups:

- T Type label (as void label or with security seal D or A).
- D Security seal or module D/F label (depending on the type label).
- A Alternative approval marking. Either as integrated part of the type label or covering the type label (e.g. DK268 mark or DK268 mark and year mark).
- R Re-verification marking (suggested position).

In Figure 60 the following examples for marking ULTRAFLOW® 44 as a heat-, cooling- or bifunctional heat-/cooling meter are shown:

- I. ULTRAFLOW® 44 marked as a heat meter.
- II. ULTRAFLOW® 44 marked as a bifunctional heat- and cooling meter.
- III. ULTRAFLOW® 44 marked as a cooling meter.

⚡ Sealing and marking requirements may vary as a consequence of national regulations.

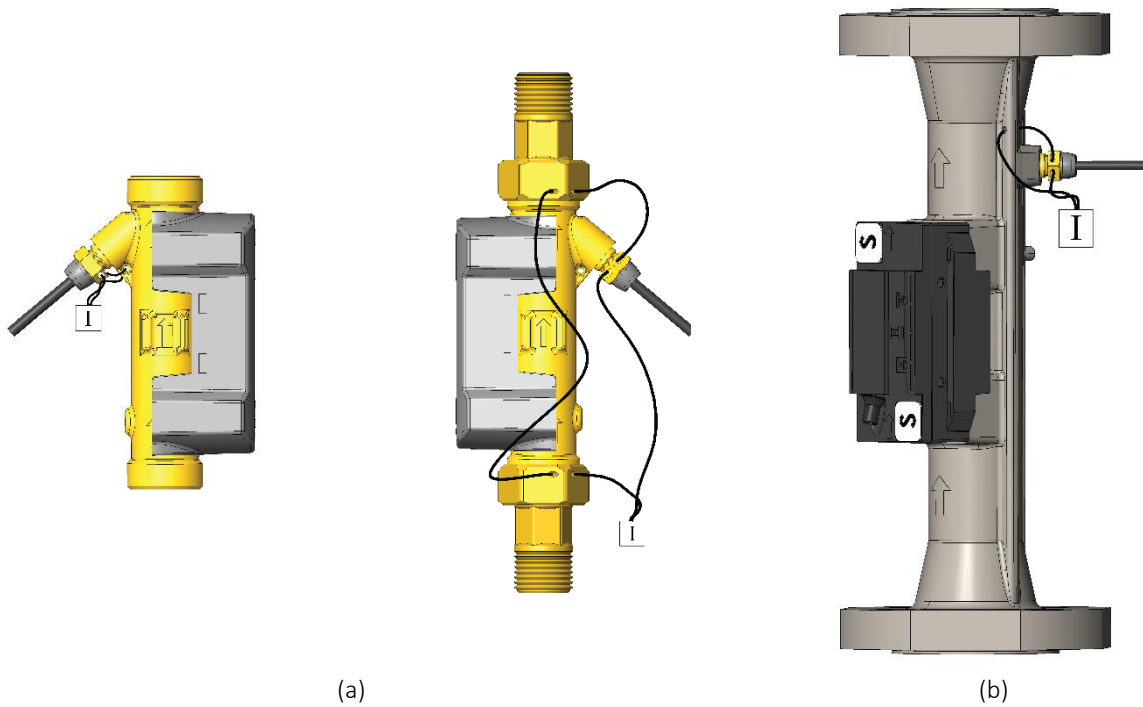

Figure 61. Sealing of couplings and temperature sensor mounted in ULTRAFLOW® 44 with wire and seal.
 (a) (Type 65-4-XXHX-XXX), (b) (Type 65-4-XXCX-XXX and 65-4-XXJX-XXX)

⚡ The top cover of the flow sensors qp 1.5 and 2.5 m³/h serve in addition to water resistance as a legal seal, because any attempt of fraud to get access to the transducers will be visible by physical damage.

In the drawings, sealing is divided into the following groups:

- S Laboratory marking. Sealing of screws.
- I Installation seal (wire and seal or sealing label).

⚡ Sealing and marking requirements may vary as a consequence of national regulations.

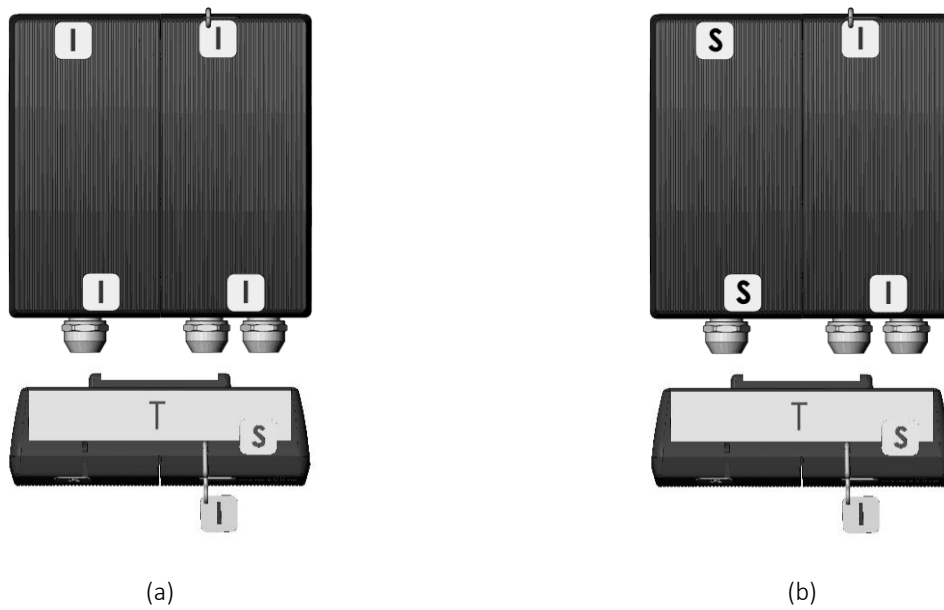

Figure 62. Sealing of (a) Pulse Transmitter/ (b) Pulse Divider.



Figure 63. Sealing of Cable Extender Box seen from (a) the front and (b) from the side.

In the drawings, sealing is divided into the following groups:

- S Laboratory marking. Sealing of screws.
- T Type label (as void label or with security seal D).
- I Installation seal (wire and seal or sealing label).

⚠ Sealing and marking requirements may vary as a consequence of national regulations.

9 Software for Kamstrup heat/cooling meters

Adjusting of ULTRAFLOW® flow sensors is supported from Kamstrup for authorized laboratories. The adjustment is performed through Kamstrup's software METERTOOL HCW 6699-724 or LabTool. Please contact the Kamstrup Product Service in Denmark (service@kamstrup.com) for additional information.

To program Pulse Divider and to configure pulses in ULTRAFLOW® 54 DN150-300, the software METERTOOL HCW 6699-724 is used. For more information, see the Technical description of METERTOOL HCW (FILE100002360_EN).

To adjust ULTRAFLOW® 44, see paragraph *8.6 Adjustment of ULTRAFLOW® flow sensors with Kamstrup software*.

💡 To achieve the easiest possible adjustment (e.g. during re-verification) we recommend to order ULTRAFLOW® 44 together with MULTICAL® 603 or MULTICAL® 803, whereby the flow sensor and the calculator will be delivered with identical serial number. Adjustment of separately delivered ULTRAFLOW® 44 requires individual encryption keys.

For further information, please see paragraph *8.6 Adjustment of ULTRAFLOW® flow sensors with Kamstrup software*.

10 Approvals

10.1 MID and DK-BEK 1178 – 06/11/2014

ULTRAFLOW® 44 is approved as heat meter in accordance with MID 2014/32/EU:

EU type examination certificate: DK-0200-MI004-044

applied standards and documents:

EN 1434:2007/AC:2007

EN 1434:2015 + A1:2018

EN 1434:2022 and

WELMEC 7.2:2022

MID certification according to Module D: DK-0200-MID-D-001

ULTRAFLOW® 44 is approved as cooling meter in accordance with DK-BEK 1178 – 06/11/2014:

System designation: TS 27.02 014

applied standards and documents:

EN 1434:2007/AC:2007

EN 1434:2015 + A1:2018

EN 1434:2022 and

WELMEC 7.2:2022

Verification: DANAK accreditation 268 for testing and calibration

Please contact Kamstrup A/S for further details on type approval and verification.

10.2 CE marking

In addition, ULTRAFLOW® 44 is marked according to the following directives, where necessary:

EMC directive 2014/30/EU

LV directive 2014/35/EU (when connected to mains-supplied Pulse Transmitter or Pulse Divider)

PE directive 2014/68/EU (DN50...DN125 category I)

10.3 EU declaration of conformity

With each ULTRAFLOW® 44 DN15-125 delivered from Kamstrup, an EU declaration of conformity is provided, see Kamstrup documentation no. 5512-1996.

11 Troubleshooting

Before sending in the sensor for repair or testing, please use the error detection table below to help you clarify the possible cause of the problem.

| Symptom | Possible cause | Proposal for correction |
|--|--|---|
| No updating of display values | No power supply | Replace battery or check mains supply |
| No display function (blank display) | No power supply and backup | Replace back-up cell. Replace battery or check mains supply |
| No accumulation of m ³ | No volume pulses Incorrect connection Flow sensor is inverted Air in sensor/cavitation Flow sensor error | Check flow sensor connection (Check with PULSE TESTER, if necessary) Check flow sensor direction Check installation angle. Check if there is air in the system or cavitation from valves and pumps. If possible, try to increase the static pressure Replace the flow sensor/send meter for repair |
| Erroneous accumulation of m ³ | Erroneous programming Air in sensor/cavitation Flow sensor error | Check that meter factors of calculator and flow sensor correspond Check the installation angle. Check if there is air in the system or cavitation from valves and pumps. Increase the static pressure, if possible Replace the flow sensor/send sensor for repair |

Table 38. Troubleshooting for heat and cooling meters.

12 Disposal

Kamstrup A/S holds an environmental certification according to ISO 14001 and as part of Kamstrup's environment policy, materials that can be recovered environmentally correctly are used to the greatest possible extent.

Kamstrup A/S has climate accounts (Carbon footprint) for all meter types.

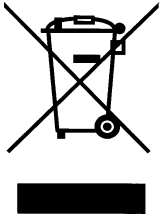

Kamstrup's heat meters are marked according to the EU directive 2012/19/EEC and the standard EN 50419.

The purpose of the marking is to inform our customers that the heat meter cannot be disposed of as ordinary waste.

- **Disposal by Kamstrup A/S**

Kamstrup A/S accepts worn-out meters for environmentally correct disposal according to previous agreement. The disposal is free of charge to our customers, except for the cost of transportation to Kamstrup A/S.

- **The customer sends for disposal**

The meters must not be disassembled prior to dispatch. The complete meter is handed in for approved national/local disposal. Enclose a copy of this page in order to inform the recipient of the contents.

Lithium cells and meters including lithium cells must be packed, marked and forwarded as dangerous goods (see also Kamstrup document 5510-408, "Lithium batteries - Handling and disposal"). Batteries must NOT be subjected to mechanical shock and the cables must NOT be able to be short circuited during transport.

| Meter part | Material | Recommended disposal |
|---|---|---|
| Lithium cells in Pulse Transmitter/ Pulse Divider (D-cell) | Lithium and thionyl chloride > UN 3091 < D-cell: 4.9 g lithium | Recycling and combustion |
| PCBs in Pulse Transmitter, Pulse Divider and ULTRAFLOW® | Coppered epoxy laminate, components soldered on | PCB scrap for concentration to metals |
| Flow sensor cables | Copper with silicone mantle | Cable recycling |
| Plastic parts, cast | PES, PC and ABS. See material data | Plastic recycling |
| ULTRAFLOW® meter case | DZR brass and stainless steel | Metal recycling |
| Packing | Recycled cardboard and EPS | Cardboard recycling (Resy) and EPS recycling |

Table 39. Recommended disposal of ULTRAFLOW® parts.

Please send any questions you may have regarding environmental matters to:

Kamstrup A/S
 Att.: Quality and environmental dept.
 Fax: +45 89 93 10 01
 info@kamstrup.com

13 Technical documentation

| | Danish | English | German |
|---------------------------------|---------------------------------|---------------------------------|---------------------------------|
| Technical description | | | |
| ULTRAFLOW® 54 DN15-125 | FILE100001275_DK (5512-2463) | FILE100001282_EN (5512-2464) | FILE100001285_DE (5512-2465) |
| ULTRAFLOW® 44 DN15-125 | FILE100000272_DK (5512-2589) | FILE100000287_EN (5512-2599) | FILE100000290_DE (5512-2600) |
| ULTRAFLOW® 54 DN150-300 | FILE100000872_DK (5512-875) | FILE100000894_EN (5512-876) | FILE100003581_DE (5512-877) |
| Data sheet | | | |
| ULTRAFLOW® 54 DN15-125 | FILE100000563_DA (5810-1546) | FILE100000564_EN (5810-1547) | FILE100000565_DE (5810-1548) |
| ULTRAFLOW® 44 DN15-125 | FILE100001166_DA (5810-1753) | FILE100001165_EN (5810-1751) | FILE100001519_DE (5810-1754) |
| ULTRAFLOW® 54 DN150-300 | FILE100001799_DA (5810-834) | FILE100001801_EN (5810-835) | FILE100001802_DE (5810-836) |
| Installation guide | | | |
| ULTRAFLOW® & MULTICAL® 603 | - 5512-2231 | FILE100002838_EN 5512-2231 | - 5512-2231 |
| ULTRAFLOW® & MULTICAL® 803 | - 5512-2408 | FILE100002839_EN 5512-2408 | - 5512-2408 |
| ULTRAFLOW® 54 DN150-300 | 5512-886 | 5512-887 | 5512-888 |
| Pulse Transmitter/Pulse Divider | 5512-1387 | 5512-1421 | 5512-1422 |
| Cable Extender Box | 5512-2008 | 5512-2008 | 5512-2008 |

Table 40. Technical documentation for ULTRAFLOW®.