

Data sheet

LON TP/FT-10 inputs (In-A, In-B)

MULTICAL® 603

MULTICAL® 803

- Compatible with EN14908/EU
- Free topology communication
- Twisted pair transceiver
- Communication speed up to 78.125 Kbits/s
- No polarity on bus terminals



Contents

Introduction	3
Applications	3
Installation	3
Cable connections	4
Communication from module	5
Network variables	6
Technical specifications	9
Ordering	10
Configuration	10
Displayed information	11

Introduction

A new high-performance and flexible LON module is available for the MULTICAL® 603 and MULTICAL® 803 energy meters. The LON communication module enables the MULTICAL® energy meters to be integrated into a building automation system or to be part of industrial applications. The LON network is a 2-wire high-speed communication bus.

Applications

The LON module design focuses on high flexibility to fulfil a wide range of applications. The LON module supports fast exchange of meter data, e.g. flow, energy and temperatures, to facilitate monitoring and control tasks.

Analysis

MULTICAL® energy meters support high quantities of data, and all data relevant for analysis can be read out.

Alarms

The MULTICAL® info codes for general alarms, flow errors, temperature errors, water leakage, very high flow, air in the system and incorrect flow direction are available to the BACnet® system.

Control and regulation

Data can be read out at intervals of few seconds at very high speed whereby the data can be used for control and regulation purposes.

Installation

The module is easily mounted on a free module space in the meter.

The LON module does not require any configuration.

The LON neuron ID comes with the module as a barcode printed on stickers. One sticker is placed on the PCB side of the module along with two extra adhesive stickers to be used for commissioning.

The neuron ID is for commissioning the LON module together with the belonging XIF file.

If the neuron ID stickers are lost, the neuron ID can be read via the meters display.

To activate the LON service PIN, invoke the "CALL" function on the meter. "Call" is invoked by pressing the left and right buttons on the meter simultaneously for approx. 5 seconds.

Cable connections

Terminals

Max cable size 1.5 mm²

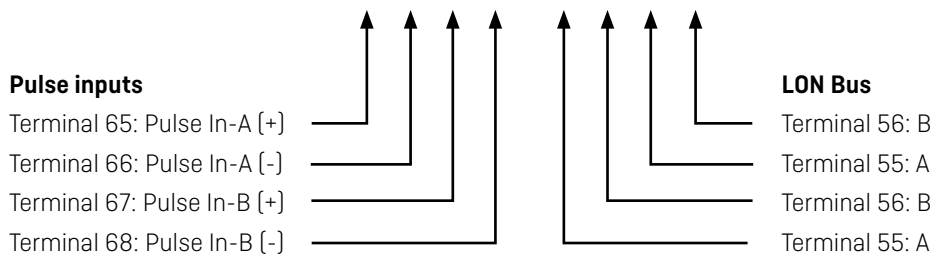

Pulse inputs

The module is equipped with two pulse inputs, In-A and In-B, to collect and accumulate pulses, e.g. from water and electricity meters.

The pulse inputs are physically placed on the module. However, the accumulation and logging of values are performed by the MULTICAL® calculator.

When installing a module with pulse inputs in slot 2 of MULTICAL® 603 and MULTICAL® 803, the pulse inputs will be registered in the meter as In-A2 and In-B2.

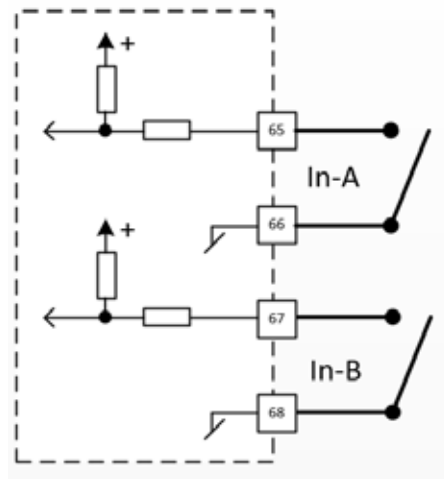

LON Bus

⚡ Two sets of LON Bus terminals enable looping of the bus wires inside the meter.

Communication from module

Protocol

Designed according to LonMark® Interoperability Guidelines v3.4.

LON addressing

The module contains a unique neuron ID. This neuron ID is needed for commissioning the module.

The neuron ID is marked on the module and is readable on the display of MULTICAL® as well.

Communication speed

The module supports 78.125 Kbits/s.

LON data

The module transfers the MULTICAL® internal data registers into LON network variables, SNVTs, which exchange information over the LON network. The SNVTs are contained in the device interface file (XIF file), which is available on the Kamstrup home page.

Meter registers are readable as either floating-point variables or as "RAW" binary values. In case of float values, LON only operates with predefined SI units. The module converts all readings from the meter into the predefined SI units.

The RAW values reflect the data from the meter with decimal point and measuring unit.

Network variables

Name	Index	Type	Unit	Description
	0	SNVT_obj_request		
Name	index	Type	Unit	Description
nviRequest	0	SNVT_obj_request		
nvoStatus	1	SNVT_obj_status		
nvoSerialNumber	2	SNVT_str_asc	ascii string	Serial number
nvoV1_Flow	3	SNVT_flow_f	l/s	Flow 1
nvoV2_Flow	4	SNVT_flow_f	l/s	Flow 2
nvoPowerV1	5	SNVT_power_f	W	Actual power
nvoTemperature1	6	SNVT_temp_p	°C	Temp. 1 inlet
nvoTemperature2	7	SNVT_temp_p	°C	Temp. 2 outlet
nvoTemperature3	8	SNVT_temp_p	°C	Temp. 3
nvoTemperature4	9	SNVT_temp_p	°C	Temp. 4
nvoTempDiff	10	SNVT_temp_p	°C	Differential temp.
nvoAnalogInput1	11	SNVT_reg_val		Analog module input 1
nvoAnalogInput2	12	SNVT_reg_val		Analog module input 2
nvoE1	13	SNVT_elec_whr_f	Wh	Heat energy E1
nvoE2	14	SNVT_elec_whr_f	Wh	Energy E2
nvoE3	15	SNVT_elec_whr_f	Wh	Cooling energy E3
nvoE4	16	SNVT_elec_whr_f	Wh	Energy E4
nvoE5	17	SNVT_elec_whr_f	Wh	Energy E5
nvoE6	18	SNVT_elec_whr_f	Wh	Energy E6
nvoE7	19	SNVT_elec_whr_f	Wh	Energy E7
nvoE8	20	SNVT_reg_val		Energy E8 [t1*m³]
nvoE9	21	SNVT_reg_val		Energy E9 [t2*m³]
nvoE10	22	SNVT_reg_val		Energy E10
nvoE11	23	SNVT_reg_val		Energy E11
nvoTA2Energy	24	SNVT_elec_whr_f	Wh	Tariff 2 - Energy
nvoTA2Volume	25	SNVT_vol_f	l	Tariff 2 - Volume
nvoTA3Energy	26	SNVT_elec_whr_f	Wh	Tariff 3 - Energy
nvoTA3Volume	27	SNVT_vol_f	l	Tariff 3 - Volume
nvoTA4Energy	28	SNVT_elec_whr_f	Wh	Tariff 4 - Energy
nvoTA4Volume	29	SNVT_vol_f	l	Tariff 4 -Volume
nvoA1	30	SNVT_elec_whr_f	Wh	Heat with discount A1
nvoA2	31	SNVT_elec_whr_f	Wh	Heat with surcharge A2
nvoV1_Volume	32	SNVT_vol_f	l	Volume
nvoV2_Volume	33	SNVT_vol_f	l	Volume V2
nvoInputAVolume	34	SNVT_vol_f	l	Pulse input A - Volume*
nvoInputAEnergy	35	SNVT_elec_whr_f	Wh	Pulse input A - Energy*
nvoInputBVolume	36	SNVT_vol_f	l	Pulse input B - Volume*
nvoInputBEnergy	37	SNVT_elec_whr_f	Wh	Pulse input B - Energy*
nvoInputA2Volume	38	SNVT_vol_f	l	Pulse input A2 - Volume*
nvoInputA2Energy	39	SNVT_elec_whr_f	Wh	Pulse input A2 - Energy*
nvoInputB2Volume	40	SNVT_vol_f	l	Pulse input B2 - Volume *
nvoInputB2Energy	41	SNVT_elec_whr_f	Wh	Pulse input B2 - Energy *
nvoCP	42	SNVT_reg_val		Coefficient of performance CP
nvoT5Limit	43	SNVT_temp_p	°C	t5 Limit

Network variables

Name	Index	Type	Unit	Description
nvoVBPow	44	SNVT_power_f	W	VB Power
nvoQPAvgTime	45	SNVT_time_min	min	QP Avg Time
nvoTL2Power	46	SNVT_power_f	W	Tariff Limit 2 - Power
nvoTL2Temp	47	SNVT_temp_p	°C	Tariff Limit 2 - Temperature
nvoTL2TempDiff	48	SNVT_temp_p	°C	Tariff Limit 2 - Temperature difference
nvoTL2Flow	49	SNVT_flow_f	l/s	Tariff Limit 2 - Flow
nvoTL2Time	50	SNVT_time_stamp	Date & time	Tariff Limit 2 - Time
nvoTL3Power	51	SNVT_power_f	W	Tariff Limit 3 - Power
nvoTL3Temp	52	SNVT_temp_p	°C	Tariff Limit 3 - Temperature
nvoTL3TempDiff	53	SNVT_temp_p	°C	Tariff Limit 3 - Temperature difference
nvoTL3Flow	54	SNVT_flow_f	l/s	Tariff Limit 3 - Flow
nvoTL3Time	55	SNVT_time_stamp	Date & time	Tariff Limit 3 - Time
nvoTL4Power	56	SNVT_power_f	W	Tariff Limit 4 - Power
nvoTL4Temp	57	SNVT_temp_p	°C	Tariff Limit 4 - Temperature
nvoTL4TempDiff	58	SNVT_temp_p	°C	Tariff Limit 4 - Temperature difference
nvoTL4Flow	59	SNVT_flow_f	l/s	Tariff Limit 4 - Flow
nvoTL4Time	60	SNVT_time_stamp	Date & time	Tariff Limit 4 - Time
nvoMass1	61	SNVT_mass_f	g	Mass 1
nvoMass2	62	SNVT_mass_f	g	Mass 2
nvoInfoBits	63	SNVT_state_64		Info bits
nvoHourCounter	64	SNVT_count_f		Hour counter
nvoEHourCounter	65	SNVT_count_f		Error hour counter
nvoConfigNo1	66	SNVT_str_asc	ascii string	Config no. 1
nvoConfigNo2	67	SNVT_str_asc	ascii string	Config no. 2
nvoConfigNo3	68	SNVT_str_asc	ascii string	Config no. 3
nvoConfigNo4	69	SNVT_str_asc	ascii string	Config no. 4
nvoMeterNoHigh	70	SNVT_str_asc	ascii string	Meter number (high)
nvoMeterNoLow	71	SNVT_str_asc	ascii string	Meter number (low)
nvoMeterType	72	SNVT_str_asc	ascii string	Meter type
nvoMainSubType	73	SNVT_str_asc	ascii string	Meter main/subtype
nvoDateTime	74	SNVT_time_stamp		Date and time
nviDateTime	75	SNVT_time_stamp		Current date and time
nviHeartbeat	76	SNVT_count Enable		Heartbeat
nvoTimeAlive	77	SNVT_count_32		Time alive in seconds

nviDateTime

The date and time in MULTICAL® may be adjusted by setting the time and date through this variable.

nviHeartbeat

Assigning a value from 5 to 65535 will enable the built-in heartbeat function, which will ensure that meter data is refreshed at the set intervals in the LON network. The interval is counting seconds. Setting the nviHeartbeat to "0" (zero) turns off the heartbeat function.

nvoInfobits

MULTICAL® maintains this register with its current runtime status. The register is an array of 64 bits, and if one or more of the bits are set, it signals an alarm situation. The bits are numbered from 0 to 63, and their meanings are described in this table:

Bit	Info
0	Supply voltage disconnected
1	Low battery level
2	External alarm [e.g. via KMP]
3	t1 Above measuring range or switched off
4	t2 Above measuring range or switched off
5	t1 Below measuring range or short-circuited
6	t2 Below measuring range or short-circuited
7	Wrong \hat{I}^*t (t1-t2)
8	V1 Air
9	V1 Wrong flow direction
11	V1 Increased flow (flow1 > qs, for more than 1 hour)
12	In-A1 Leakage in the system
13	In-B1 Leakage in the system
14	In-A1/A2 External alarm
15	In-B1/B2 External alarm
16	V1 Communication error
17	V1 Wrong meter factor
18	In-A2 Leakage in the system
19	In-B2 Leakage in the system
20	t3 Above measuring range or switched off
21	t3 Below measuring range or short-circuited
22	V2 Communication error
23	V2 Wrong pulse figure
24	V2 Air
25	V2 Wrong flow direction
27	V2 Increased flow (flow2 > qs, for more than 1 hour)
28	V1/V2 Burst, water loss (flow1 > flow2)
29	V1/V2 Burst, water penetration (flow1 < flow2)
30	V1/V2 Leakage, water loss (M1 > M2)
31	V1/V2 Leakage, water penetration (M1 < M2)
32..63	Reserved

The data objects are available here: [HC-003-60 Lon-580981410.ZIP](https://www.kamstrup.com/HC-003-60_Lon-580981410.ZIP)

Technical data

Physical

For installation in MULTICAL® 603 and MULTICAL® 803

Mechanical data

Dimensions (L x W x D) 90 x 35 x 14 mm
Weight < 45 g

MULTICAL® supply

High-Power SMPS

Communication

Protocol LonTalk
Baud rate 78125 bit/s
Cable type 22 or 24 AWG twisted pair
Cable length <2700 m

Data refresh rate

Data from the meter to the module are refreshed each time the meter completes an integration. Integration mode is defined by the meter's L-code.

Bus-specific

Type Lon TP/FT-10
Galvanic isolation > 2 kV

Pulse inputs

Input type Contact input
Open voltage 3.6 V
Current ≤ 5 µA
Max cable length 10 m

Environment

Operational temperature 5 °C – 55 °C
Humidity 25 – 85 % RH non-condensing

Markings/approvals

CE, MID together with the type approval of MULTICAL® 603 and MULTICAL® 803

Compatibility

EN14908/EU LON standard

Programming

Firmware Via the LON bus using a LON commissioning tool

Ordering

Description

LON TP/FT-10, inputs (In-A, In-B)
 USB configuration cable for H/C modules
 Infrared optical read-out head w/USB A plug
 METERTOOL HCW

Order No.

HC-003-60
 6699-035
 6699-099
www.kamstrup.com

Configuration

	XX	YY	ZZZ
Product type of module			
LON TP/FT-10, inputs (In-A, In-B)	60	00	100
Channel type			
TP/FT-10		00	
Datagram			
Default datagram			100

Displayed information

Module information can be read by selecting “TECH loop” on the MULTICAL® display.



Module in module slot 1: Select menu 2-101 in “TECH loop”.

Module in module slot 2: Select menu 2-201 in “TECH loop”.

Module in module slot 3: Select menu 2-301 in “TECH loop”.

Module in module slot 4: Select menu 2-401 in “TECH loop”.

Menu	Menu index	Information	Display example
2-x01	31	Module type and configuration	
2-x01-1	32	Module firmware and revision	
2-x01-2	33	Module serial number	
2-x01-3	34	Neuron ID - 1	

Menu	Menu index	Information	Display example
2-x1-4	35	Neuron ID - 2	
2-x1-5	36	Neuron ID - 3	

The euron ID is a 12-digit hexadecimal number, the node ID is however displayed in decimal as 3 successive parts. Each part must be converted into hexadecimal to combine the neuron ID.

- Neuron ID - 1 is a decimal representation of the first 4 digits 1794 -> 0x0702
- Neuron ID - 2 is a decimal representation of the middle 4 digits 24078-> 0x5E0E
- Neuron ID - 3 is a decimal representation of the last 4 digits 26368-> 0x6700

The resulting neuron ID is 07025E0E6700.